

2009 Caltrans-PEER Seismic Seminar Series

Seismic Response and Capacity Evaluation of Exterior Sacrificial Shear Keys of Bridge Abutments

Scott A. Ashford, PE, PhD
Professor and School Head
Oregon State University
Corvallis, Oregon

History of UCSD Work on Abutments

- Post-tensioned Abutments (2002)
 - Megally, Silva, and Seible
- Sacrificial Shear Keys (2007)
 - Bozorgzadeh, Bauer, Restrepo, and Ashford
- Abutment Backfill Models (2007)
 - Bozorgzadeh, Ashford, and Restrepo
 - Initially considered diaphragm-type abutments
 - Worked with EMI on backfill soil types
 - Completed testing on seat-type abutment

Acknowledgments

- The California Department of Transportation (Caltrans) is gratefully acknowledged for the financial support of the experimental research on sacrificial exterior shear keys.
- This research was carried out at UC San Diego. The participation of the UCSD faculty, staff, and students is also acknowledged.

Schematic of Exterior Shear Key in Bridge Abutments

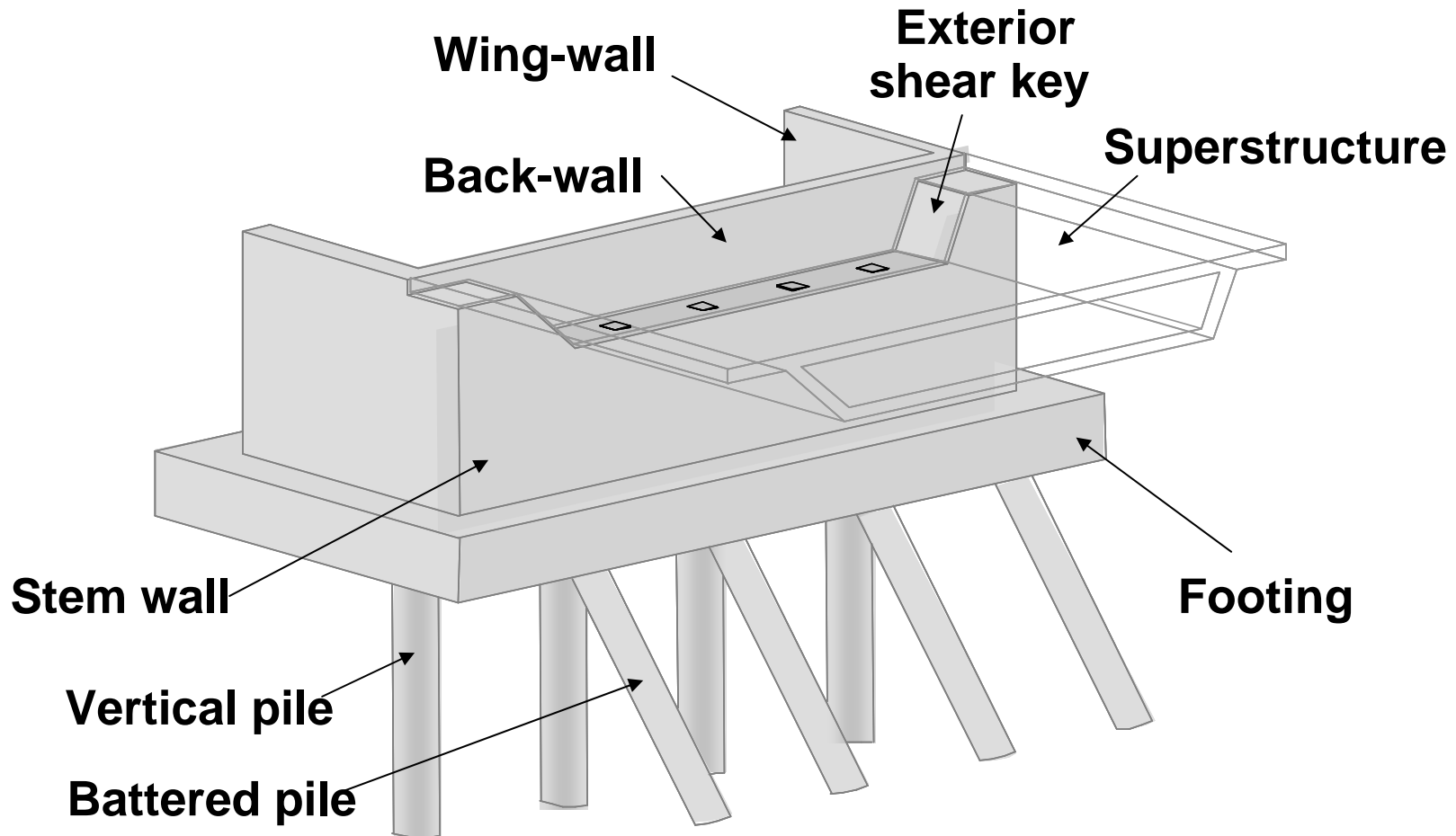

1994 Northridge Earthquake

Over half of damaged bridges suffered abutment damage

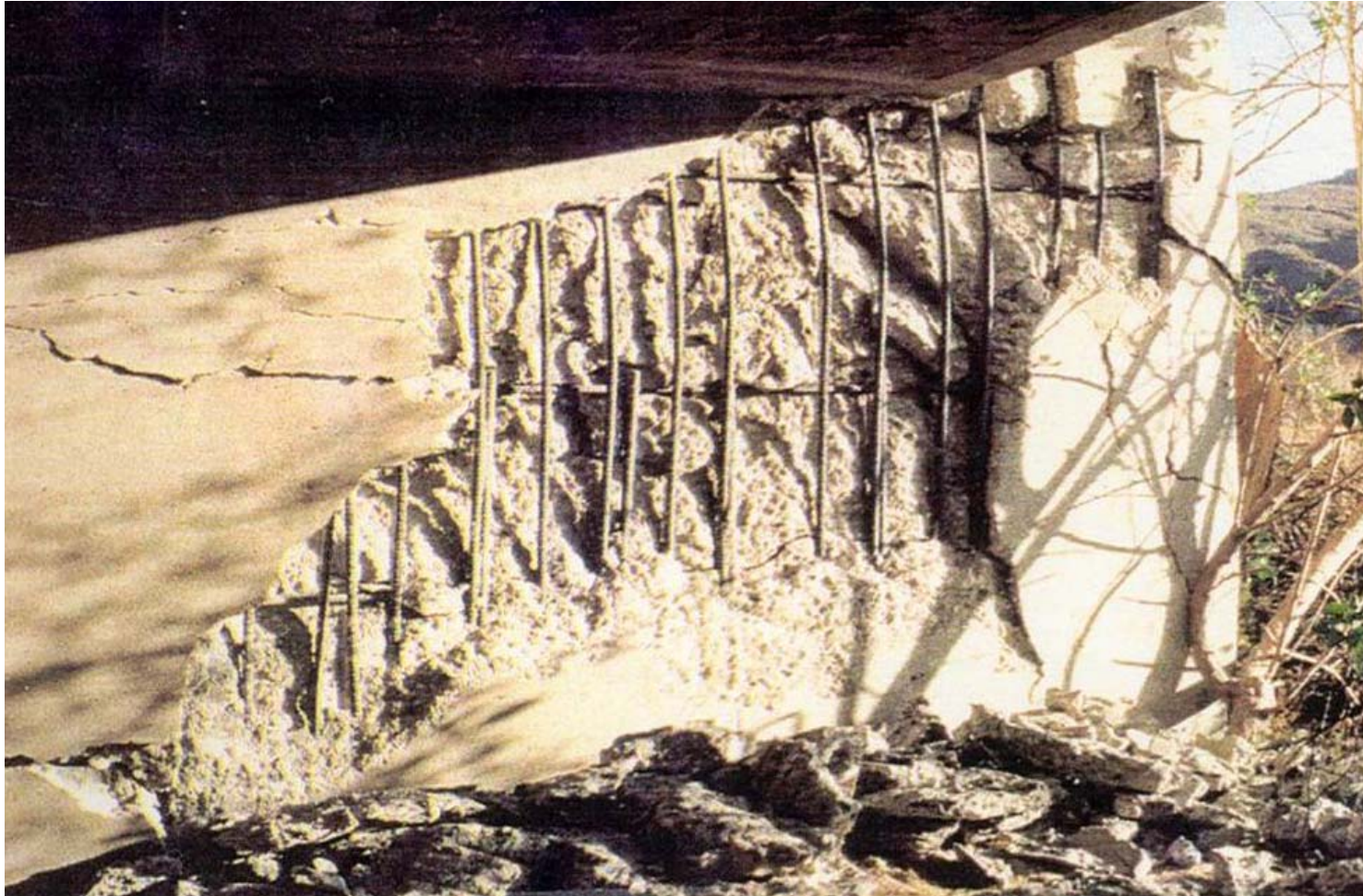

Experimental Work

- Five test series, each including two test units were built at a 40% scale.
- Main variables:
 - Construction joint.
 - Amount and configuration of vertical reinforcement.
 - Amount and configuration of horizontal reinforcement.

Elevation View of Reinforcement Layout of the Proposed Model

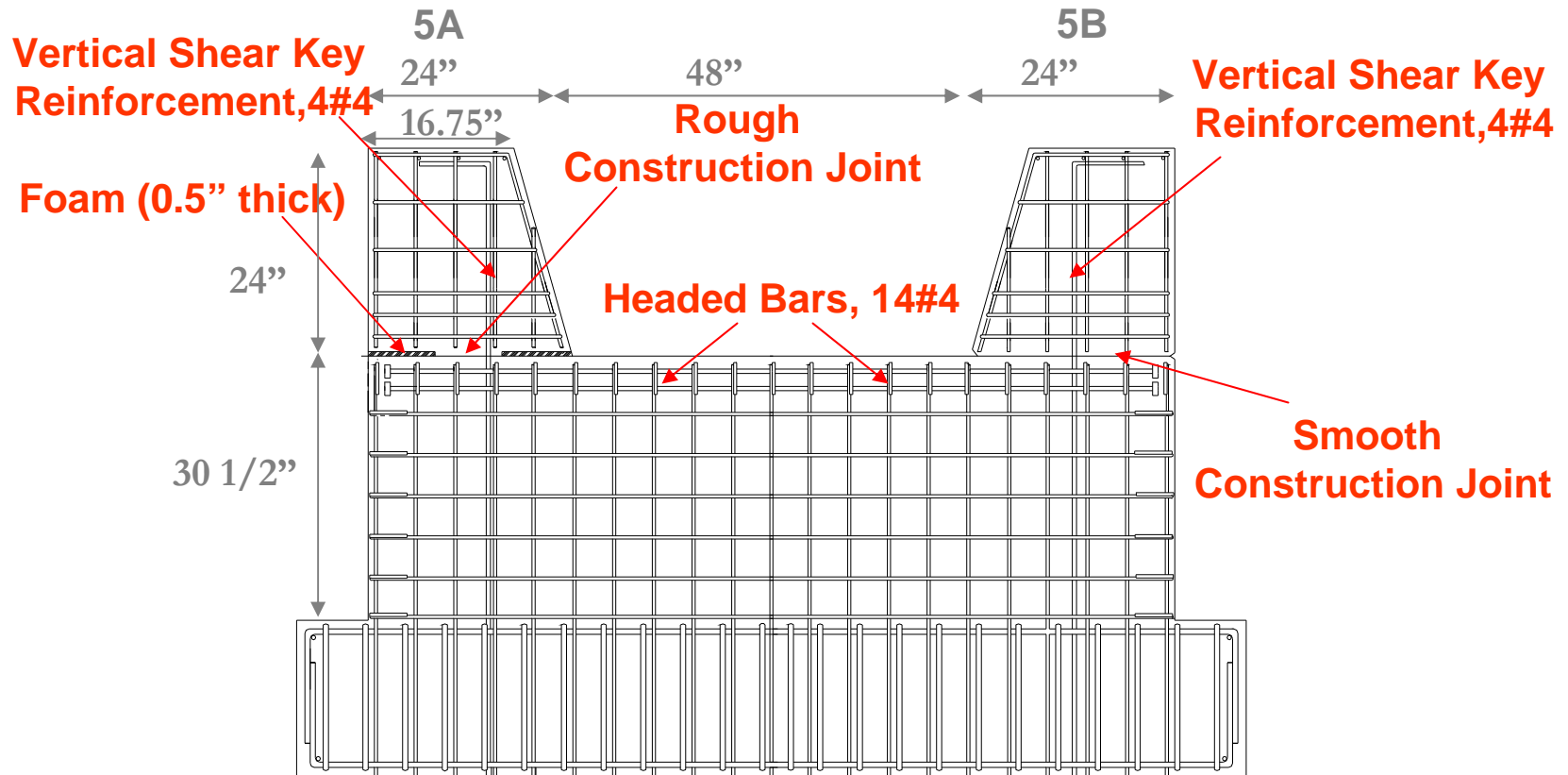

Shear Key Test Specimens Under Construction



Test Setup



Failure of Exterior Shear Keys of Two Test Series



- Failure occurred in a diagonal strut in the stem wall.
- No sliding at the interface of shear key-abutment stem wall occurred.



- Performed as structural fuses with sliding shear failure.
- Diagonal cracks formed in the stem wall but the maximum width of cracks were 0.012".

Load-Displacement Curves

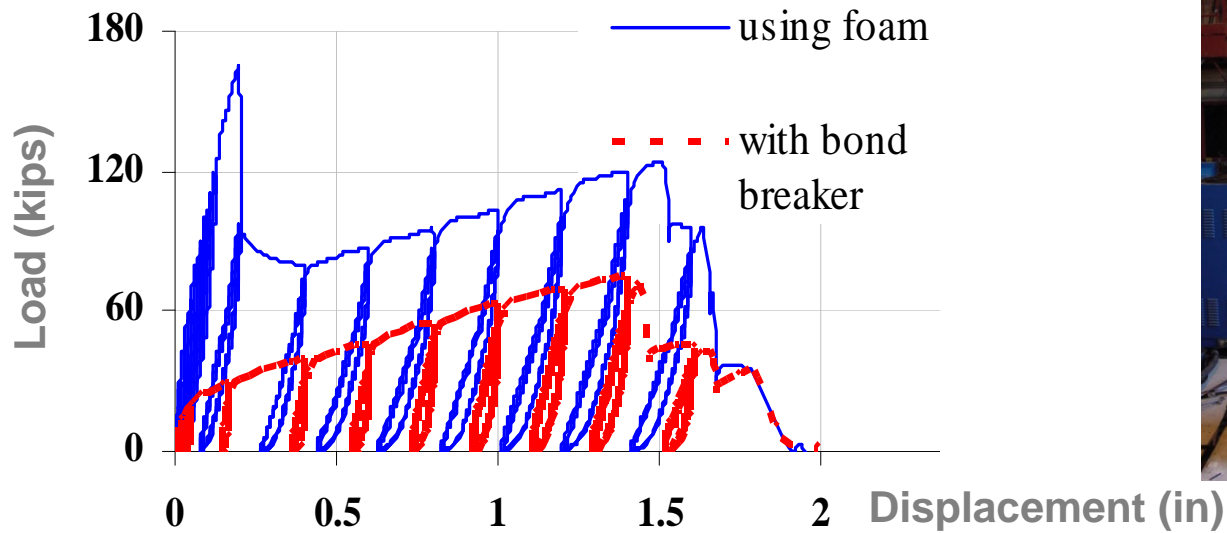
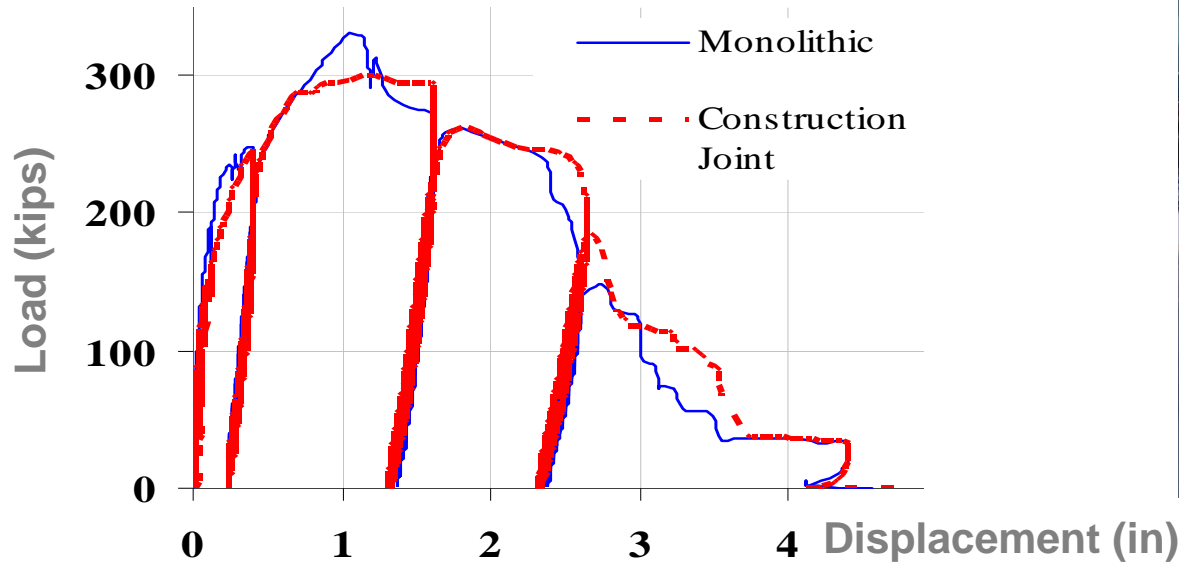

Conclusions

- A model for evaluation of capacity of shear keys under lateral force was developed based on Strut-and-Tie models.
- The proposed model showed better agreement with test results than the current shear friction model.
- The current shear friction model underestimates shear key capacity which may lead to damage of abutment wall or supporting piles.

Conclusions

- Based on results of experimental work, several recommendations were proposed for construction details:
 - Using smooth construction joint.
 - Shear key vertical reinforcement bars should be the only reinforcement connecting the shear key to the abutment stem wall.
 - Headed bars or hanger bars can be used in the stem wall to carry the force transmitted by the shear key.

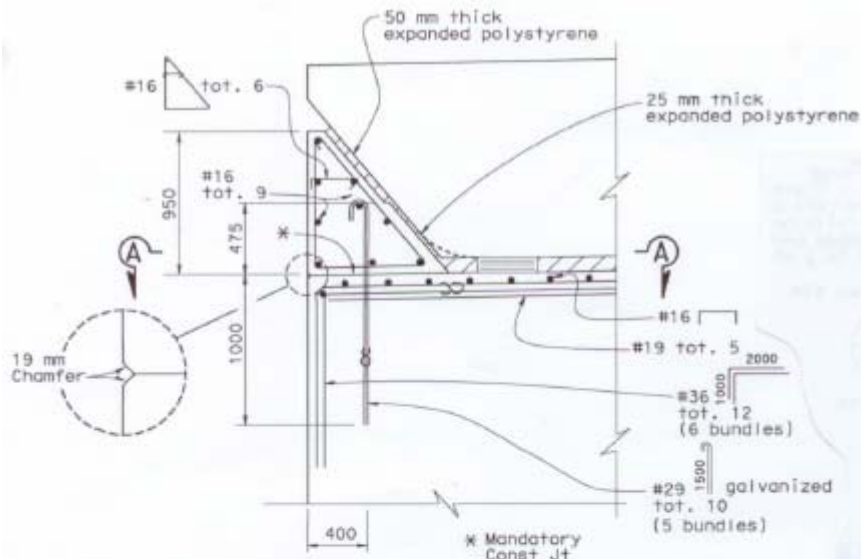

SHEAR KEY DETAIL

1:20

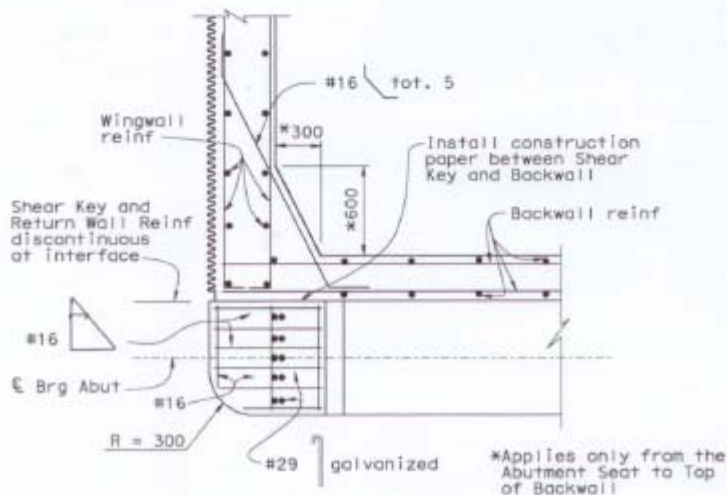

SECTION A-A

1:20

Research results implemented along I-905 in San Diego in September 2007

Most testing carried out in 2003/4, final report dated October 2007

Caltrans implements good results quickly, in this case before final report issued.

Shear Key Construction



Completed Keys



Results Available at UCSD

- SSRP-2001/22, May 2002: "Seismic Response of Sacrificial Shear Keys in Bridge Abutments," S.H. Megally, P.F. Silva, F. Seible, 215p.
- SSRP-04/14, October 2007: "Seismic Response and Capacity Evaluation of Exterior Sacrificial Shear Keys in Bridge Abutments," A. Bozorgzadeh, H.L. Bauer, J.I. Restrepo, S.A. Ashford, 40p.
- SSRP-07/12, May 2007: "Experimental and Analytical Investigation on the Stiffness and Ultimate Capacity of Bridge Abutments," A. Bozorgzadeh, S. Ashford, and J. Restrepo, 196p.