

# Slender Wall Behavior & Modeling



John Wallace

University of California, Los Angeles

with contributions from  
Dr. Kutay Orakcal  
University of California, Los Angeles



# Presentation Overview

## ◆ FEMA 356 Requirements

- General requirements
- Modeling approaches
  - ◆ Beam-column, fiber, general
- Stiffness, strength

## ◆ Experimental Results

- Model Assessment
  - ◆ Rectangular, T-shaped cross sections
- FEMA backbone relations
  - ◆ Flexure dominant walls



*FEMA 356 –  
Nonlinear Modeling for Buildings with  
Slender RC Walls*

# FEMA 356 – RC Walls

## ◆ General Considerations – 6.8.2.1

- Represent stiffness, strength, and deformation capacity
- Model all potential failure modes anywhere along the wall (member) height
- Interaction with other structural and nonstructural elements shall be considered
- So, we must consider any and everything

# Wall Modeling Approaches

- ◆ Equivalent beam-column model
  - $h_w/l_w \geq 3$
- ◆ Modified equivalent beam-column
  - Rectangular walls ( $h_w/l_w \leq 2.5$ )
  - Flanged walls ( $h_w/l_w \leq 3.5$ )
- ◆ Multiple-line-element and Fiber models
  - Concrete and rebar material models
- ◆ General wall model

# Equivalent Beam-Column Model

## ◆ $h_w/l_w \geq 3$ :

- Use of equivalent beam-column permitted
- Neutral axis migration not considered
- Interaction with in- and out-of-plane elements not properly considered
- Axial load Impacts
  - ◆ Stiffness (EI)
  - ◆ Strength (P-M)
- L- or T-shaped walls
  - ◆ Where to locate the element?
  - ◆ Elastic centroid?

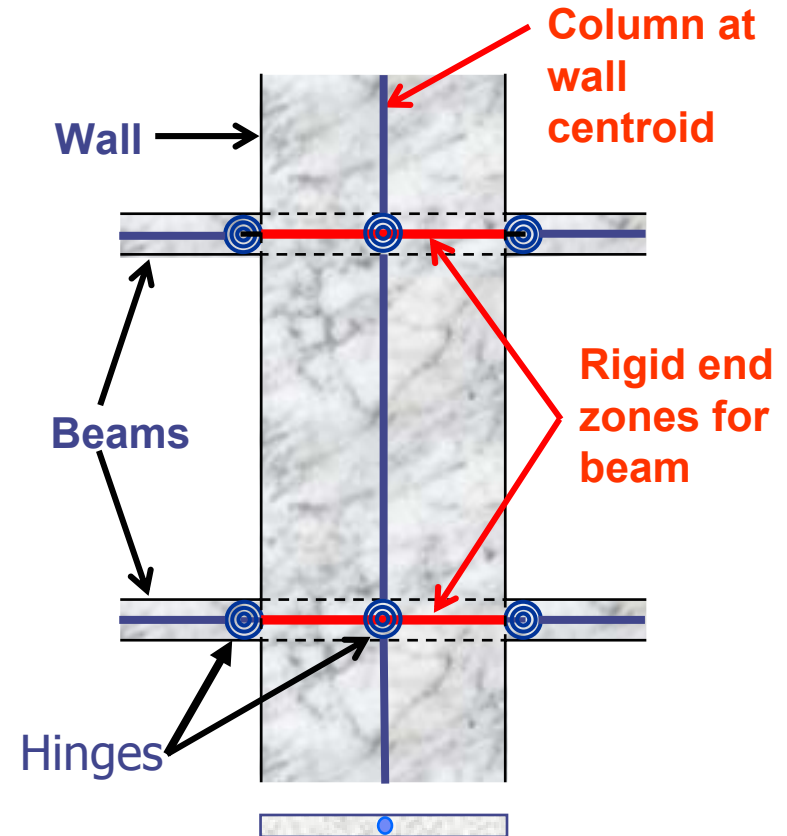

$$A_{column} = t_w l_w$$

$$I_{column} = \alpha_{cracking} \left[ \frac{1}{12} t_w l_w^3 \right]$$

# Modified Beam - Column Model

- ◆ Rectangular walls ( $h_w/l_w \leq 2.5$ )  
& Flanged walls ( $h_w/l_w \leq 3.5$ ):

*Use of modified  
beam-column element  
with added shear spring*

Nonlinear flexure/shear  
are uncoupled using this  
approach

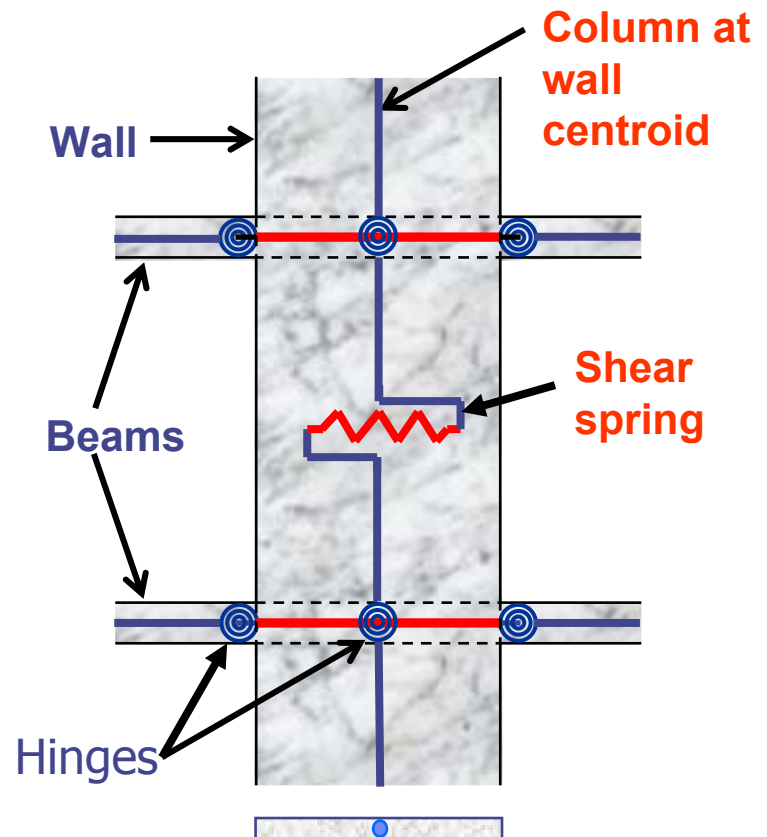

# Modified Beam - Column Model

## Shear force – deformation properties

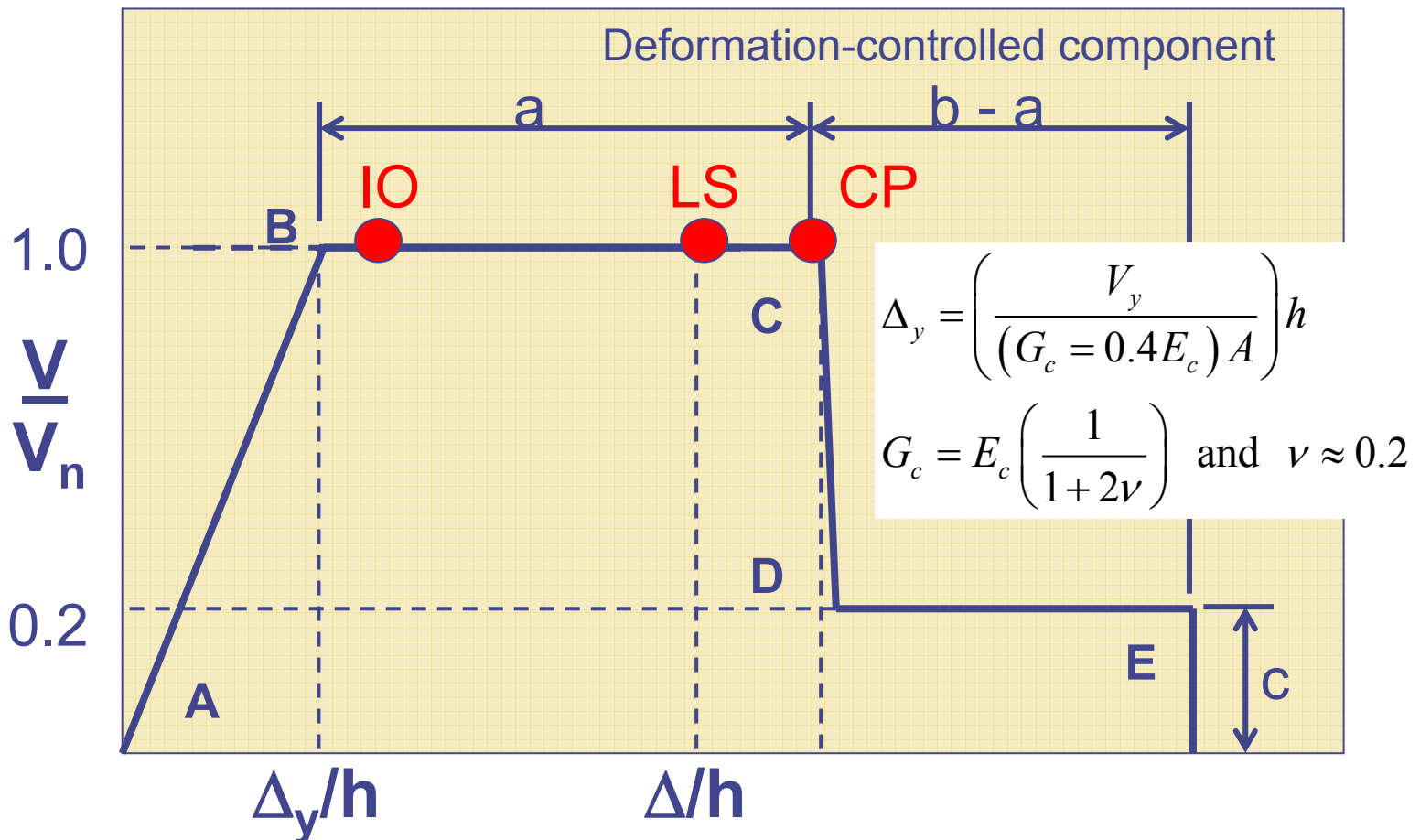

# Fiber Section Model

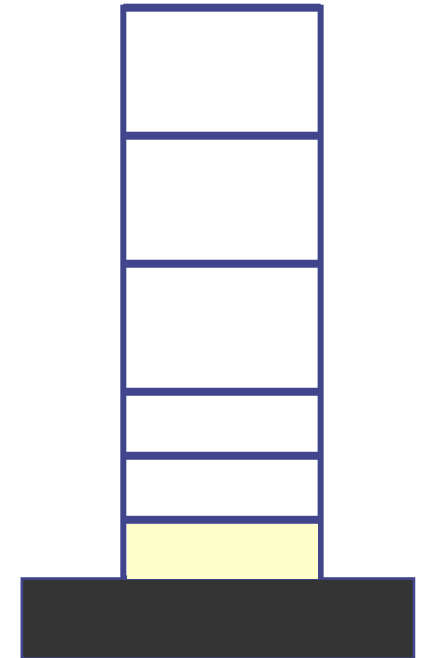
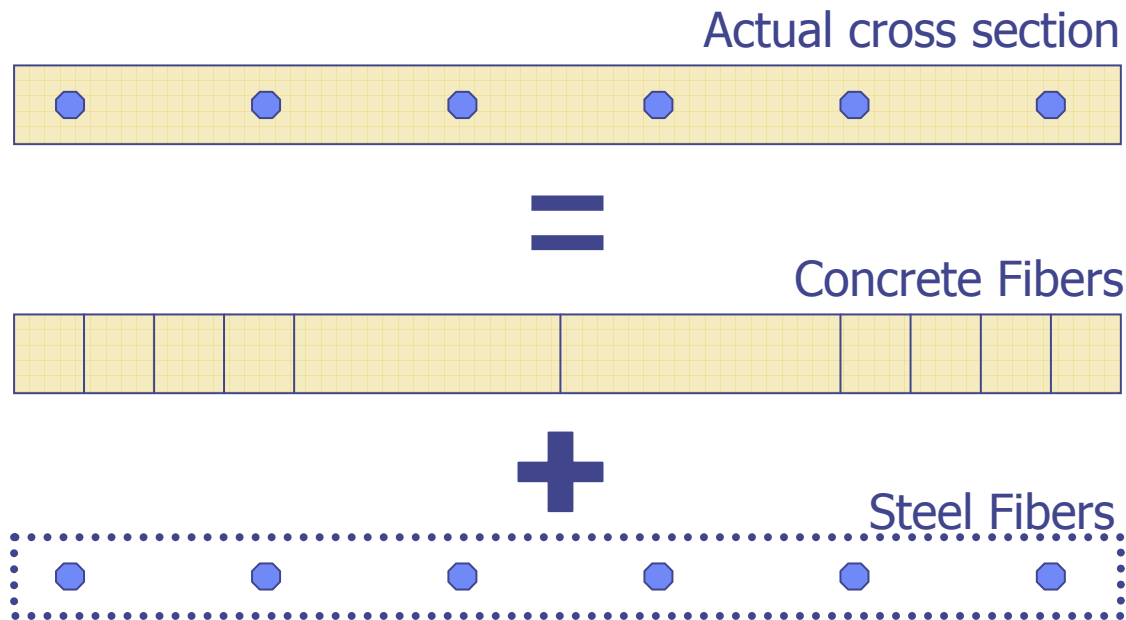

- Typically use a more refined mesh where yielding is anticipated; however,
- Nonlinear strains tend to concentrate in a single element, thus, typically use an element length that is approximately equal to the plastic hinge length (e.g.,  $0.5l_w$ ). Might need to calibrate them first (this is essential).
- Calibration of fiber model with test results, or at least a plastic hinge model, is needed to impose a "reality" check on the element size and integration points used.

# Materials

## ◆ Unconfined Concrete

Maximum permissible compressive strain for unconfined concrete (FEMA 356 S6.4.3.1)

$$\varepsilon = 0.002 \text{ or } 0.005$$

Limit state associated with crack width

Stress (ksi)

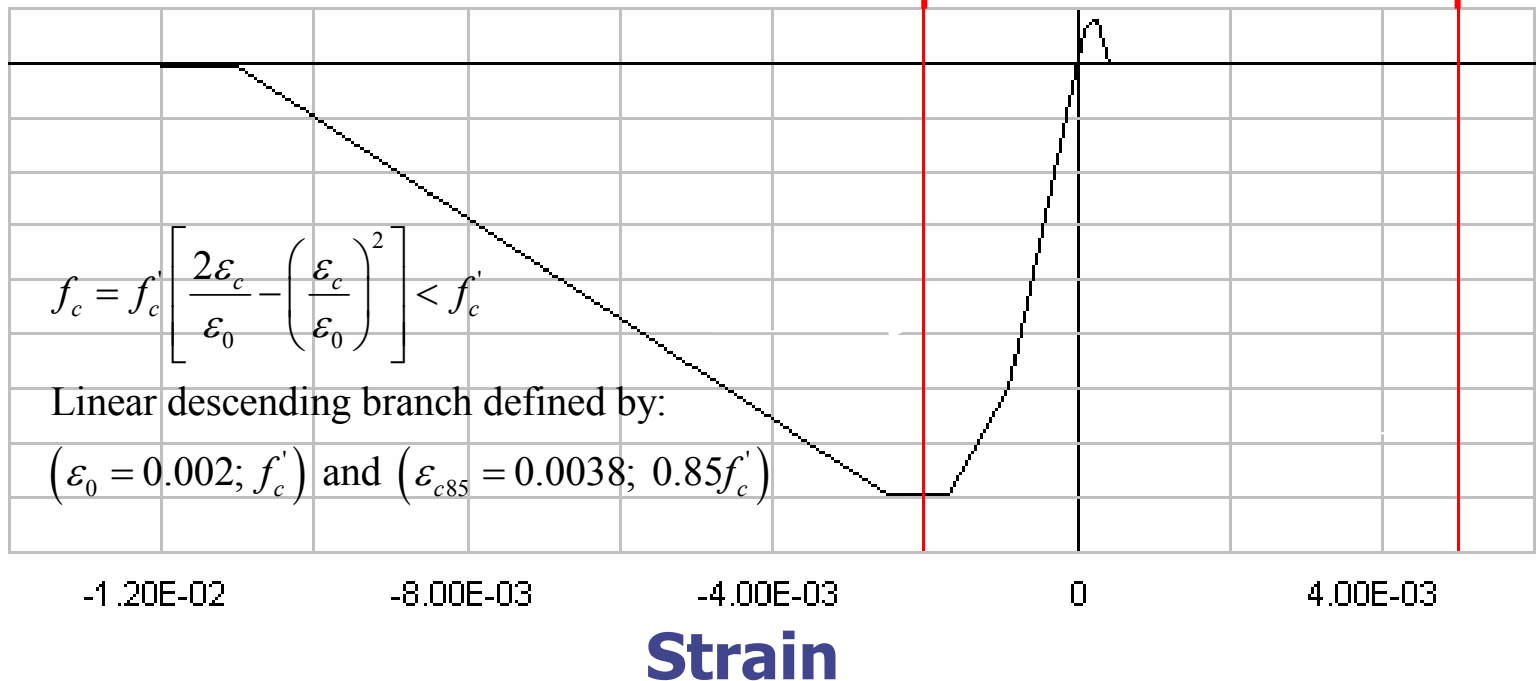

In the absence of cylinder stress-strain tests, Saatcioglu & Razvi (ASCE, JSE, 1992) recommend relation based on work by Hognestad.

# Materials

## ◆ Confined Concrete (FEMA 356 6.4.3.1)

- Use appropriate model, e.g.:

- ◆ Saatcioglu & Razvi (ASCE JSE, 1992, 1995)
- ◆ Mander (ASCE JSE, 1988)
- ◆ Modified Kent & Park (ASCE JSE, 1982)

- For reference

- FEMA 356 Qualifications:

- ◆ Maximum usable compression strain based on experimental evidence and consider limitations posed by hoop fracture and longitudinal bar buckling.

# Materials

## ◆ Steel Material:

Maximum usable strain limits per  
FEMA 356 S6.4.3.1

$$\varepsilon = 0.02$$

$$\varepsilon = 0.05$$

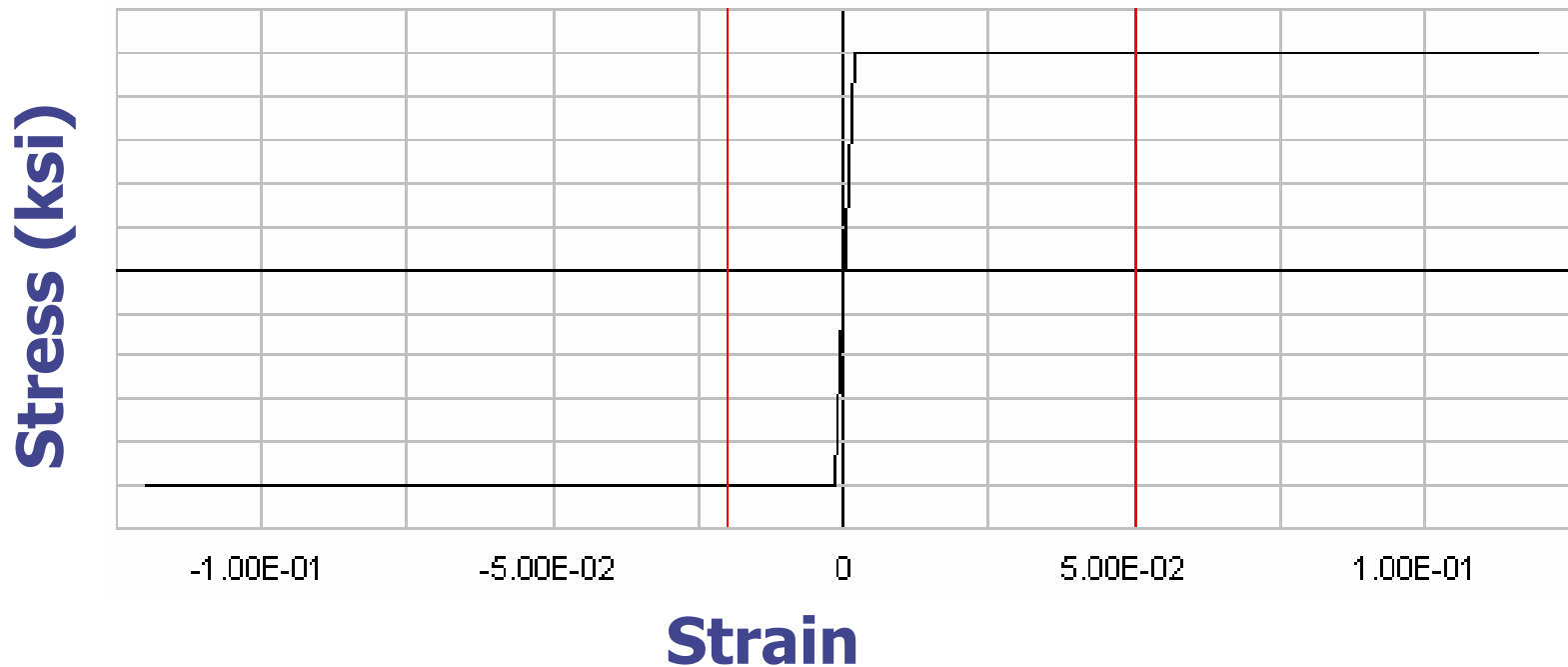

# General Wall Models/FE Models

◆ e.g., RAM-PERFORM:

- Flexure - fiber model (2-directions)
- Shear - Trilinear backbone relation
- Flexibility to model complex wall geometry
- Mesh refinement issues

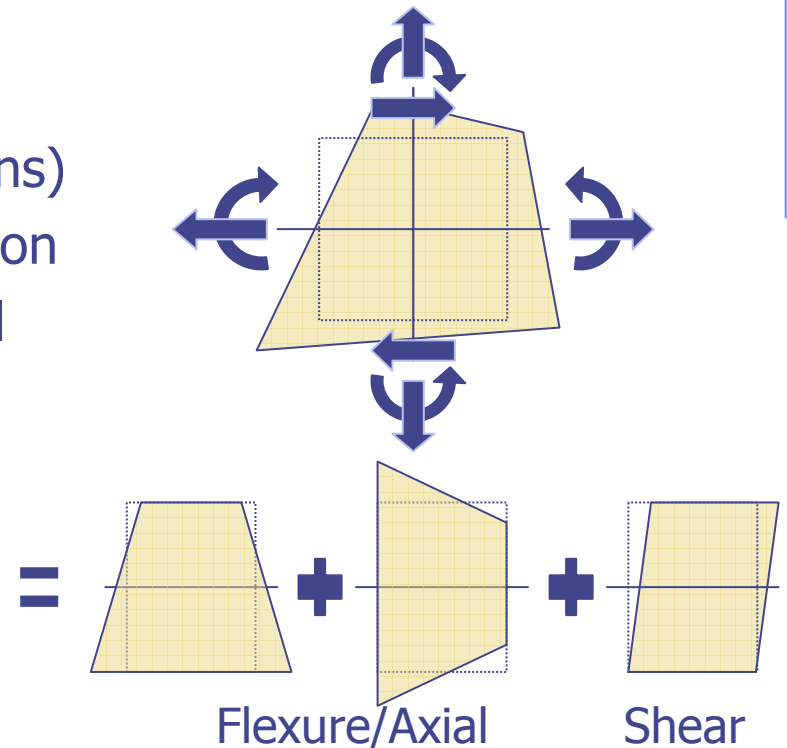
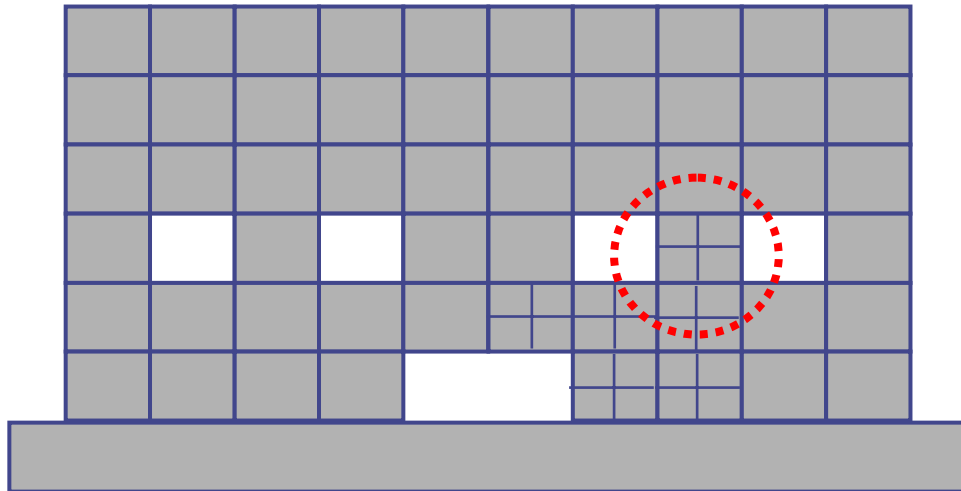

Concentration of nonlinear Deformations in one element

The diagram shows a 2x2 grid of elements on the left. A red arrow points to the right, where a single element is shown with a yellow shaded area, indicating that nonlinear deformations are concentrated in that one element.

# Stiffness Modeling

## ◆ FEMA 356 Section 6.8.2.2 – Use Table 6.5

- Uncracked:  $EI_{\text{effective}} = 0.8EI_g$
- Cracked:  $EI_{\text{effective}} = 0.5EI_g$

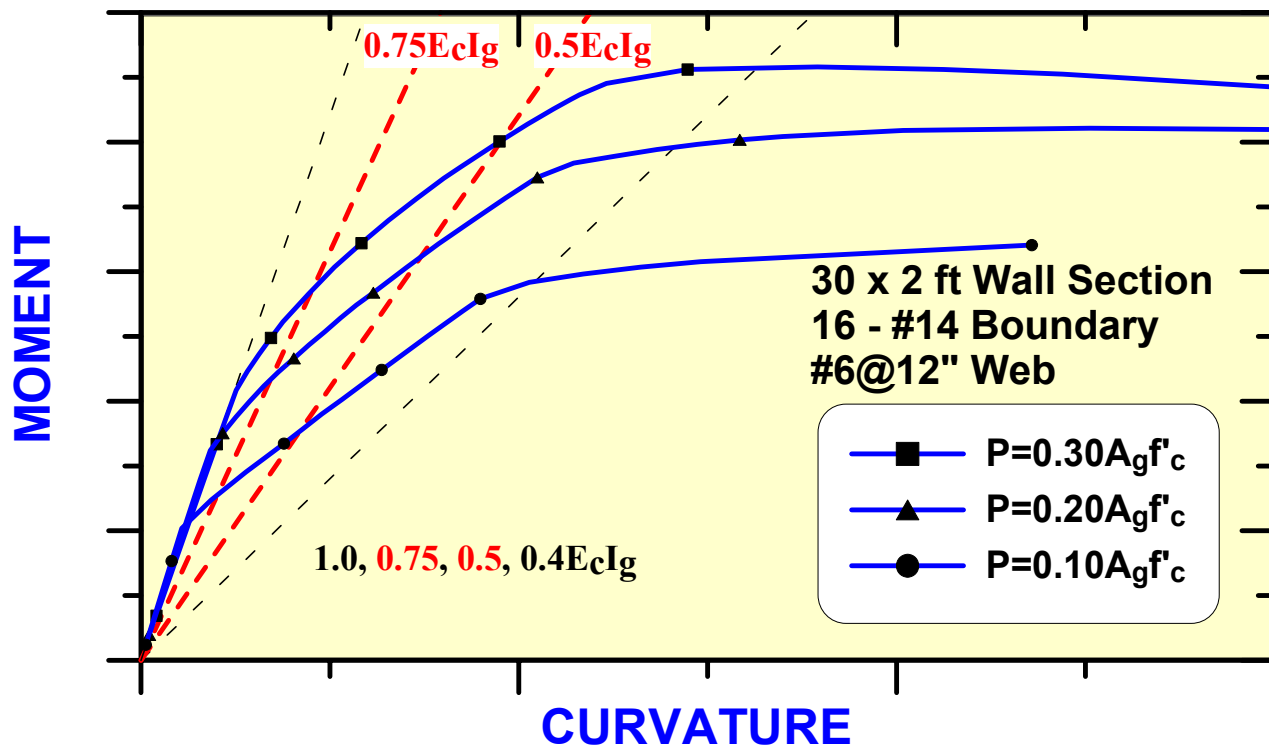

# Response Correlation Studies

- Ten Story Building in San Jose, California
- Instrumented: Base, 6th Floor, and Roof
- Moderate Intensity Ground Motions – Loma Prieta

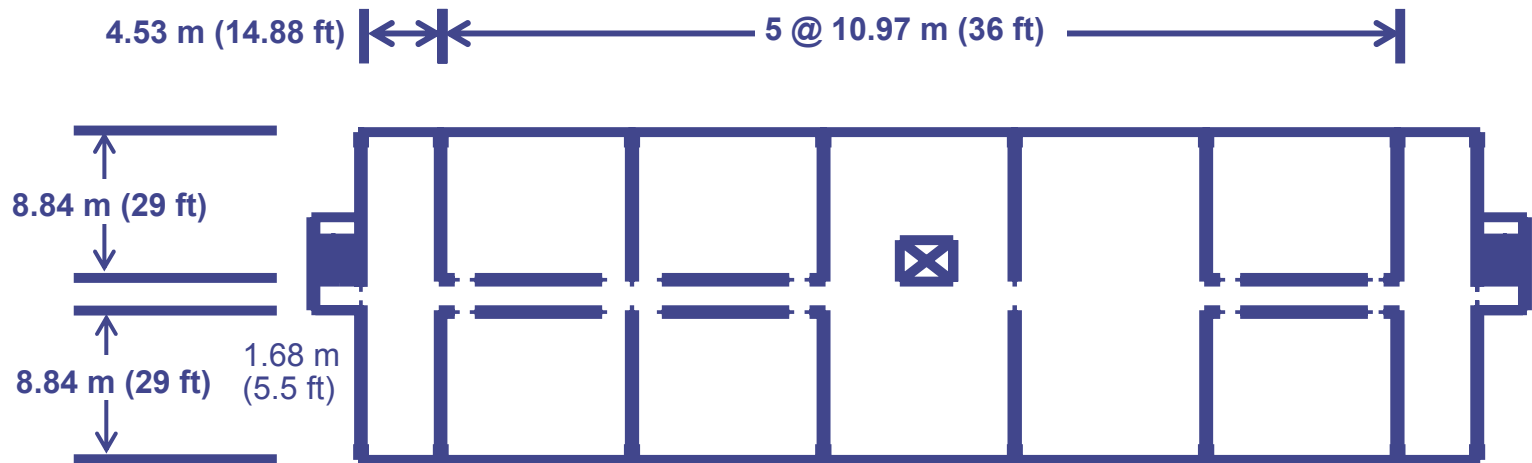

**PLAN VIEW: CSMIP BUILDING 57356**

# Response Correlation Studies

- Ten Story Building in San Jose, California
- Instrumented: Base, 6th Floor, and Roof
- Moderate Intensity Ground Motions – Loma Prieta

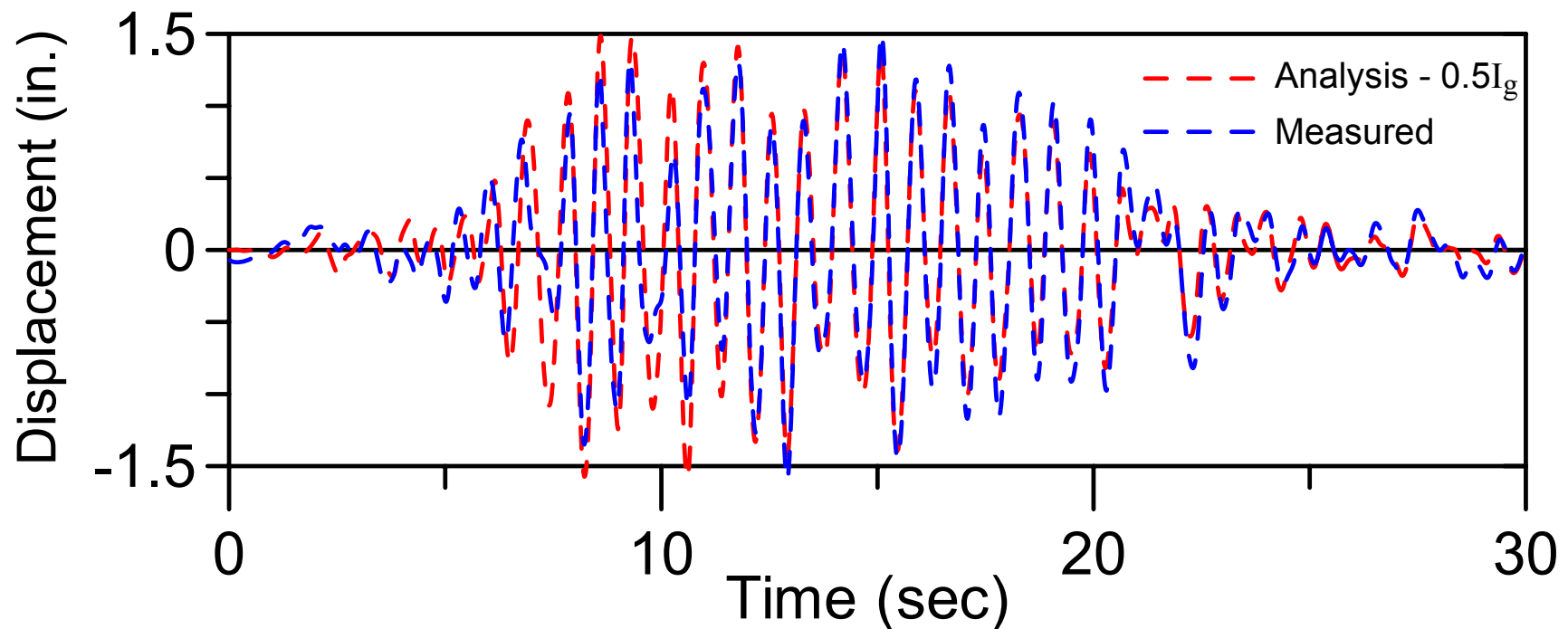

# Strength Requirements

## ◆ ACI 318 Provisions

### ■ $P_n - M_n$

- ◆ For extreme fiber compression strain of  $\varepsilon_c = 0.003$ .

### ■ $V_n$

- ◆ ACI 318-99,02,05 Equation 21-7

$$V_n = A_{cv} \left[ \alpha_c \sqrt{f'_c} + \rho_t f_y \right]$$

$$\left. \begin{array}{l} \alpha_c = 3.0 \quad \text{for } h_w / l_w \leq 1.5 \\ \alpha_c = 2.0 \quad \text{for } h_w / l_w \geq 2.0 \end{array} \right\} \text{Linear interpolation} \\ \text{allowed for intermediate} \\ \text{values}$$

# Definition of Wall Cross Section

## ◆ Cross-Section Definition

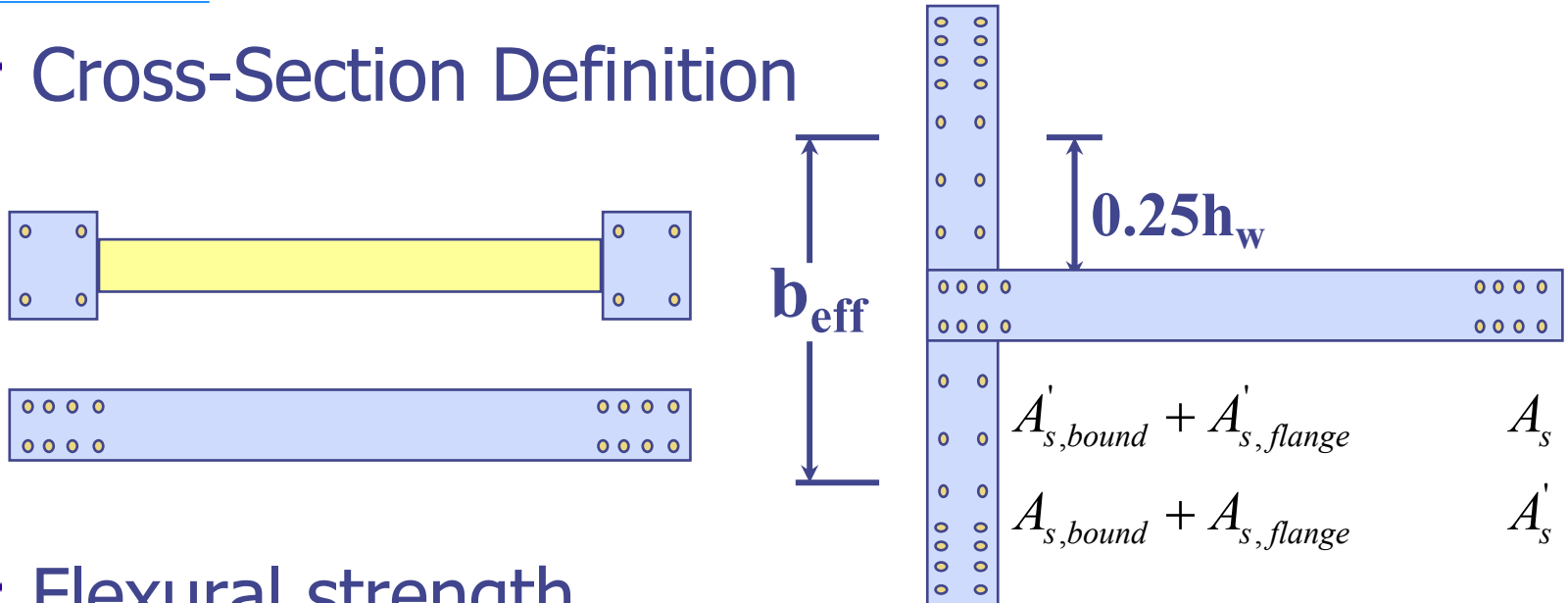

## ◆ Flexural strength

- Consider all vertical reinforcement within web and within the effective flange width
- ◆ Consider the influence of openings on the strength and detailing requirements
  - ACI 318-02, 05 Appendix A – Strut & Tie Approach

# Behavior of Flanged Walls

## ◆ Flange Compression versus Tension

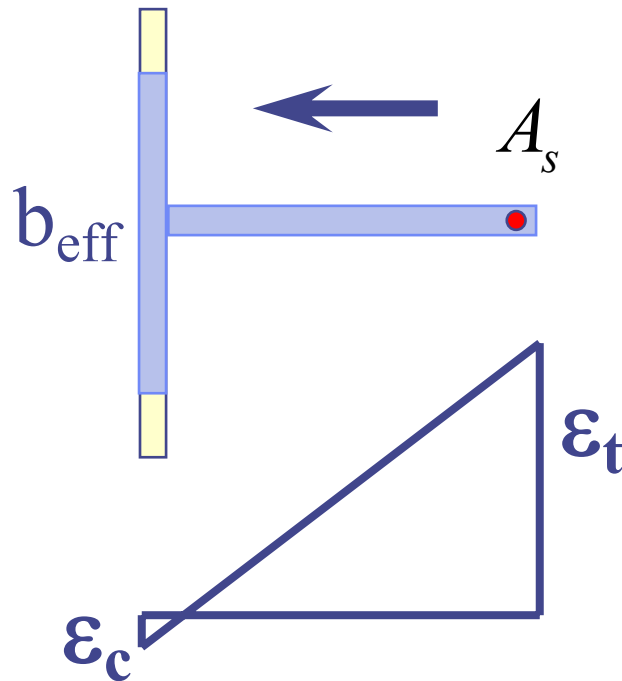

**Flange Compression**

**Low compressive strain**

**Large curvature capacity**

**$M_n$  &  $V_u$  similar rectangle**

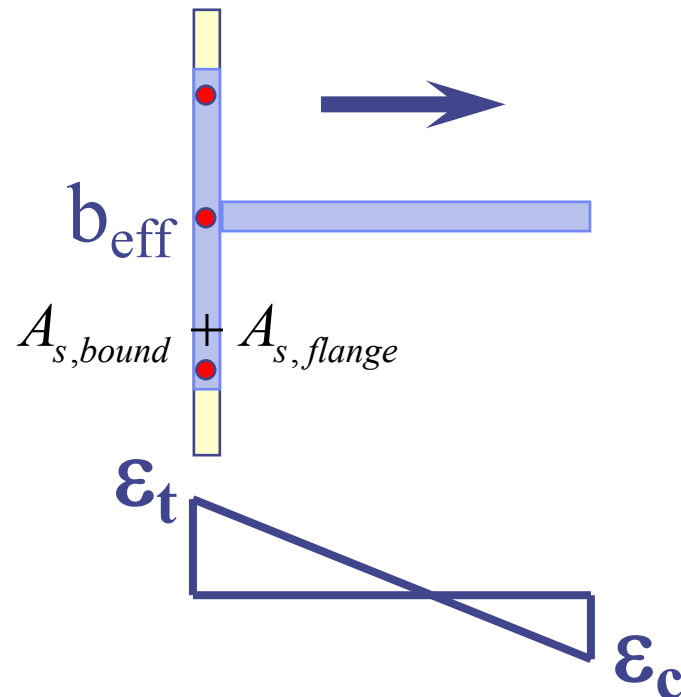

**Flange Tension**

**Large compressive strain**

**Less curvature capacity**

**$M_n \uparrow V_u \uparrow$**

# Experimental Results

◆ RW2 & TW1:  $\sim 1/4$  scale tests



Thomsen & Wallace, ASCE JSE, April 2004.

# Experimental Results

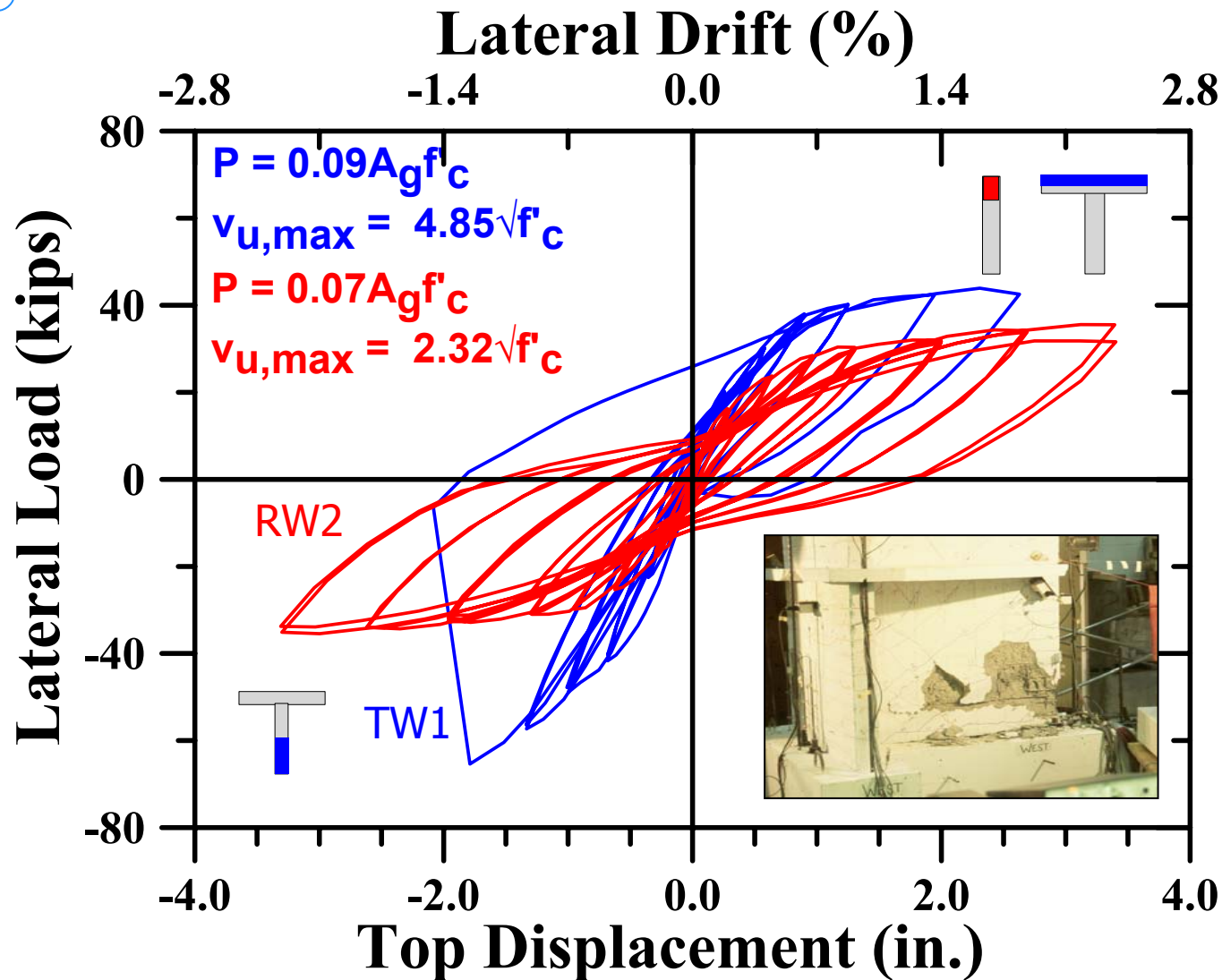

# Experimental Results

◆ RW2 & TW2:  $\sim 1/4$  scale tests



Thomsen & Wallace, ASCE JSE, April 2004.

# Experimental Results

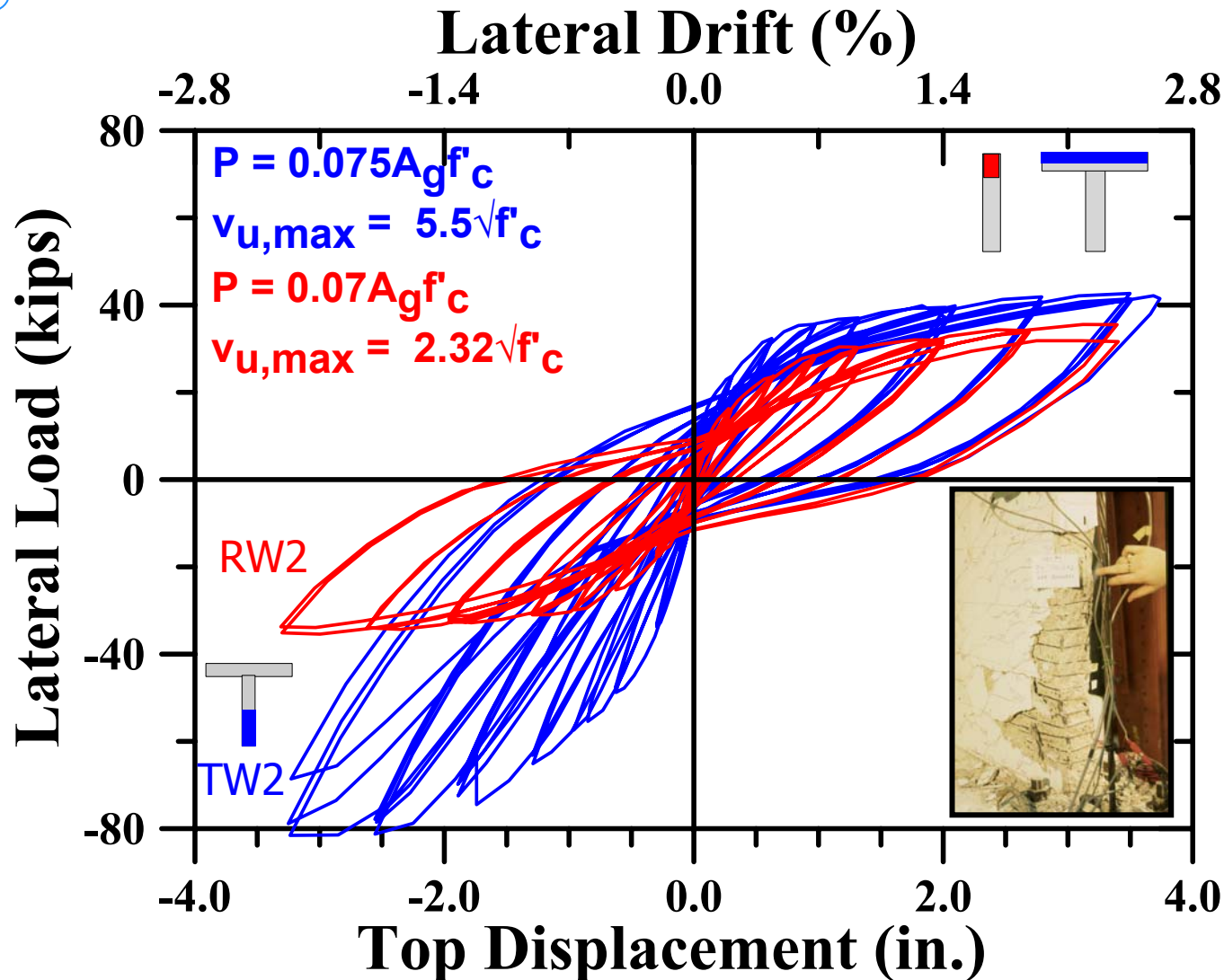



*Model Assessment –  
Comparison of Analytical and  
Experimental results*

# MVLE (Fiber) Model

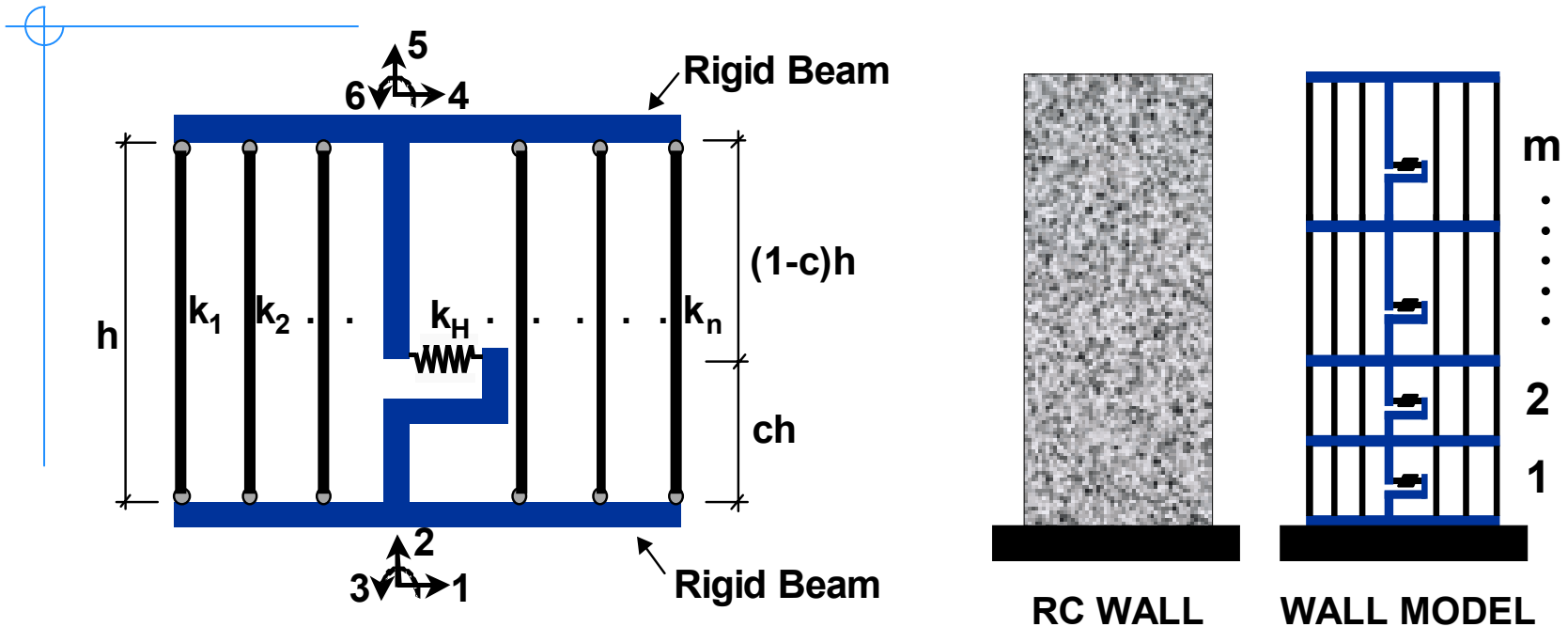

## Basic assumptions:

- Plane sections (rigid rotation of top/bottom beams)
- Uniaxial material relations (vertical spring elements)

## MVLE Model versus Fiber Model:

- Similar to a fiber model except with constant curvature over the element height (vs linear for fiber model)

# Material (Uni-axial) Models

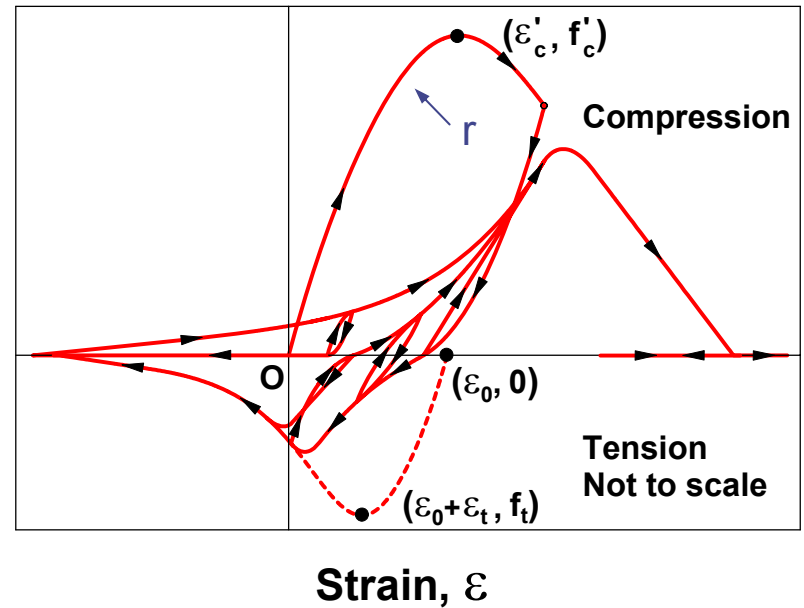
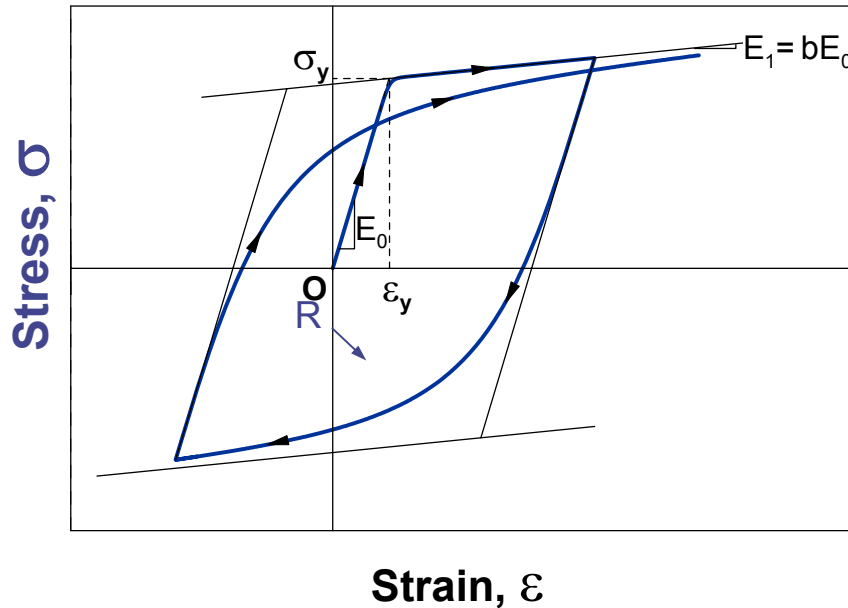

## Reinforcing Steel:

- Menegotto and Pinto (1973)
- Filippou et al. (1984)
  - Simple but effective
  - Degradation of cyclic curvature

## Concrete:

- Chang and Mander (1994)
  - Generalized (can be updated)
  - Allows refined calibration
  - Gap and tension stiffening

# Model Assessment

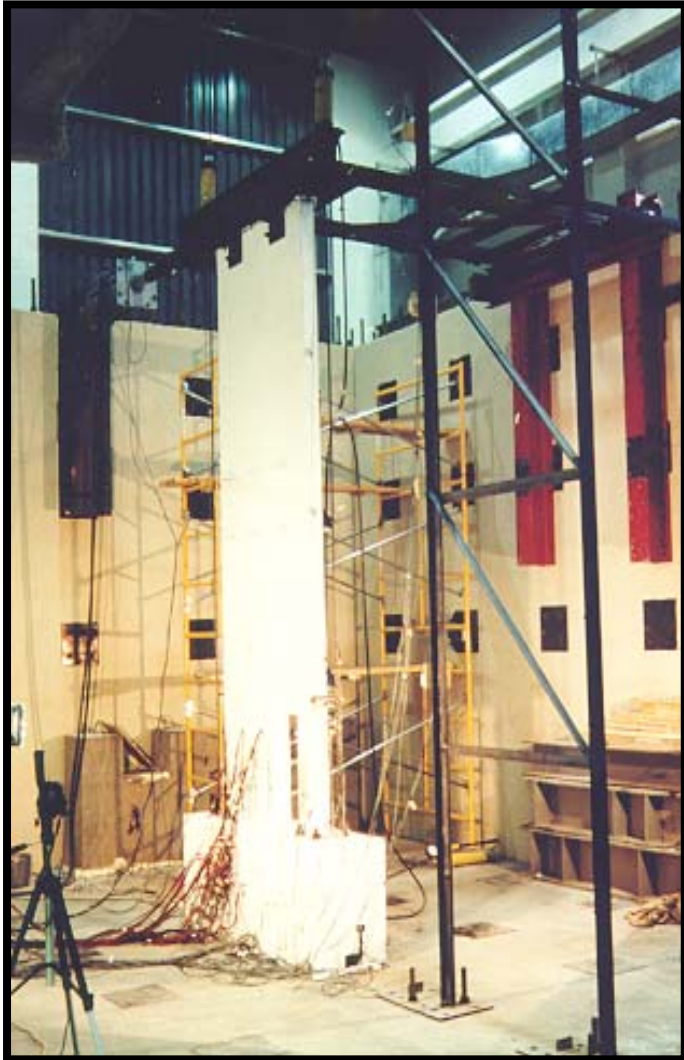

- **Approximately 1/4 scale**
- **Aspect ratio = 3**
- **Displacement – based evaluation for detailing provided at the wall boundaries**
- **12 ft tall, 4 ft long, 4 inches thick**
- **#3 vertical steel, 3/16" hoops/ties**
- **#2 deformed web steel**
- **Constant axial load**
- **Cyclic lateral displacements applied at the top of the walls**

# Instrumentation

- Extensive instrumentation provided to measure wall response at various locations

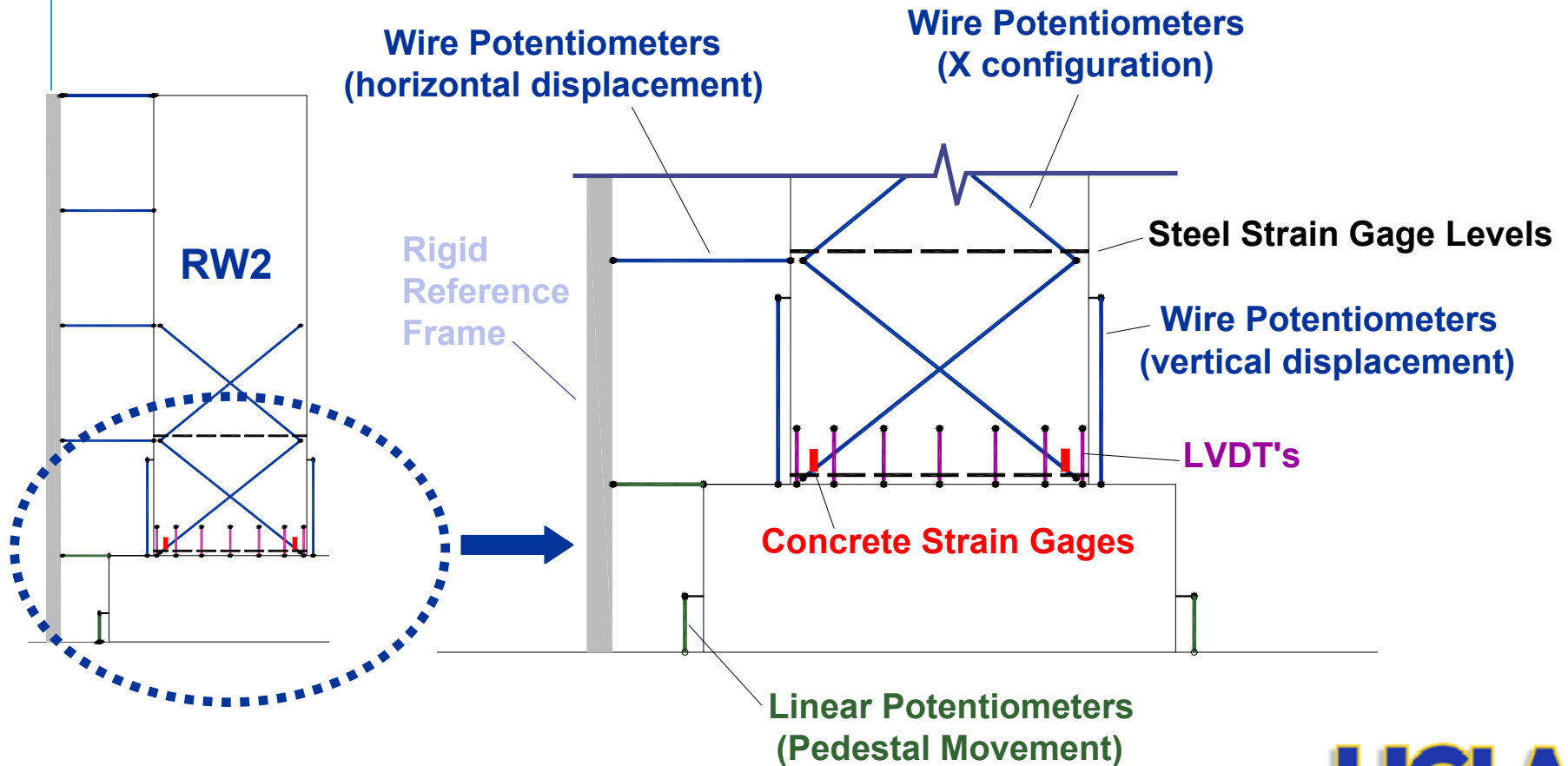

# Applied Lateral Displacement

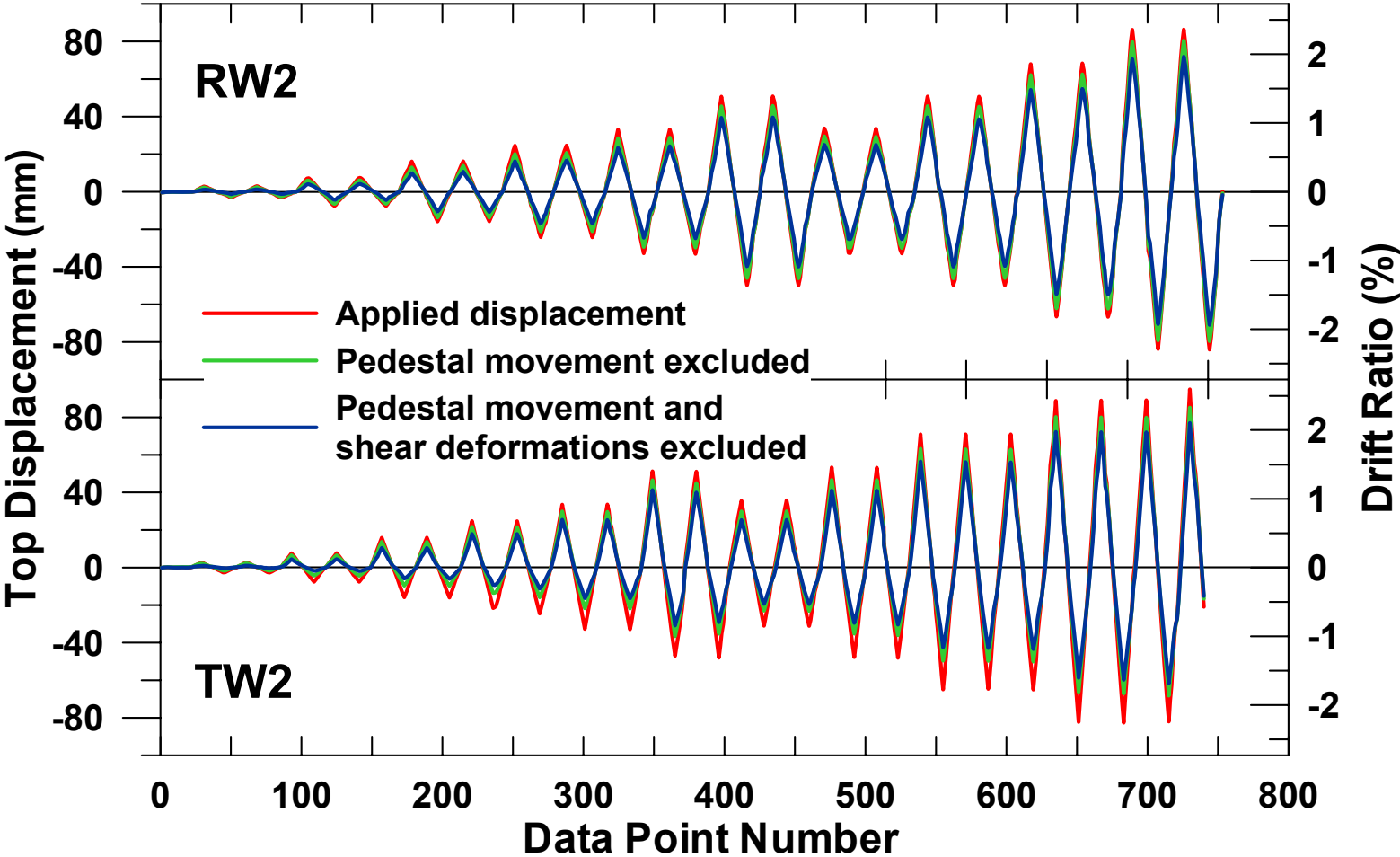

# Model Details – RW2

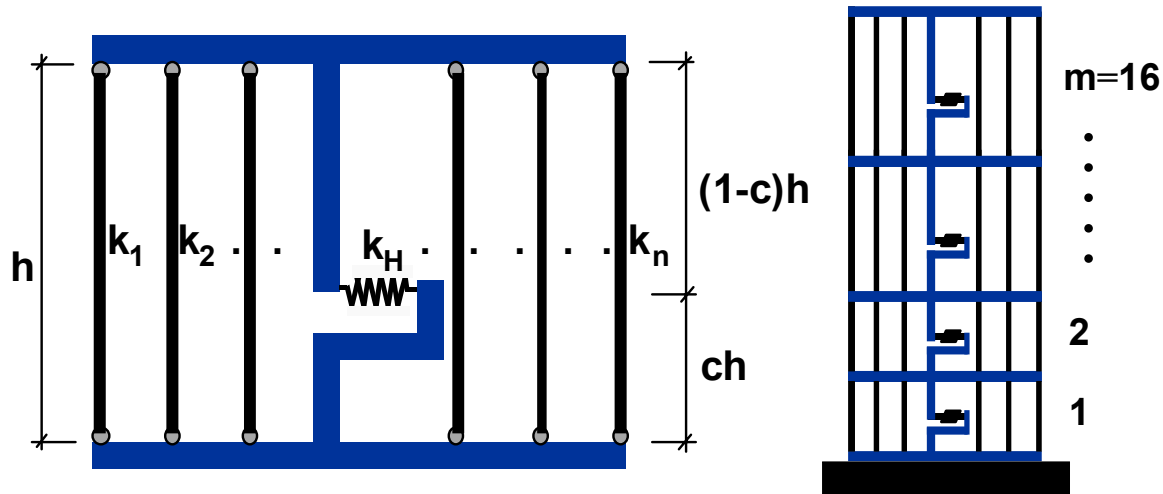
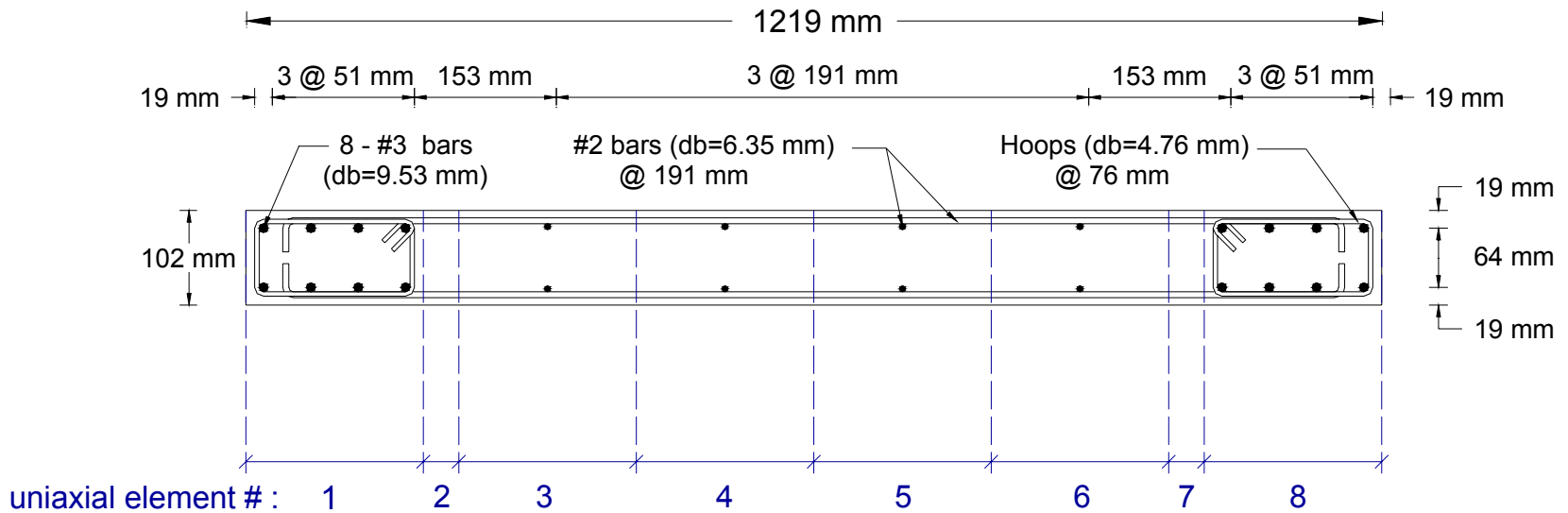

# Model Details – TW2

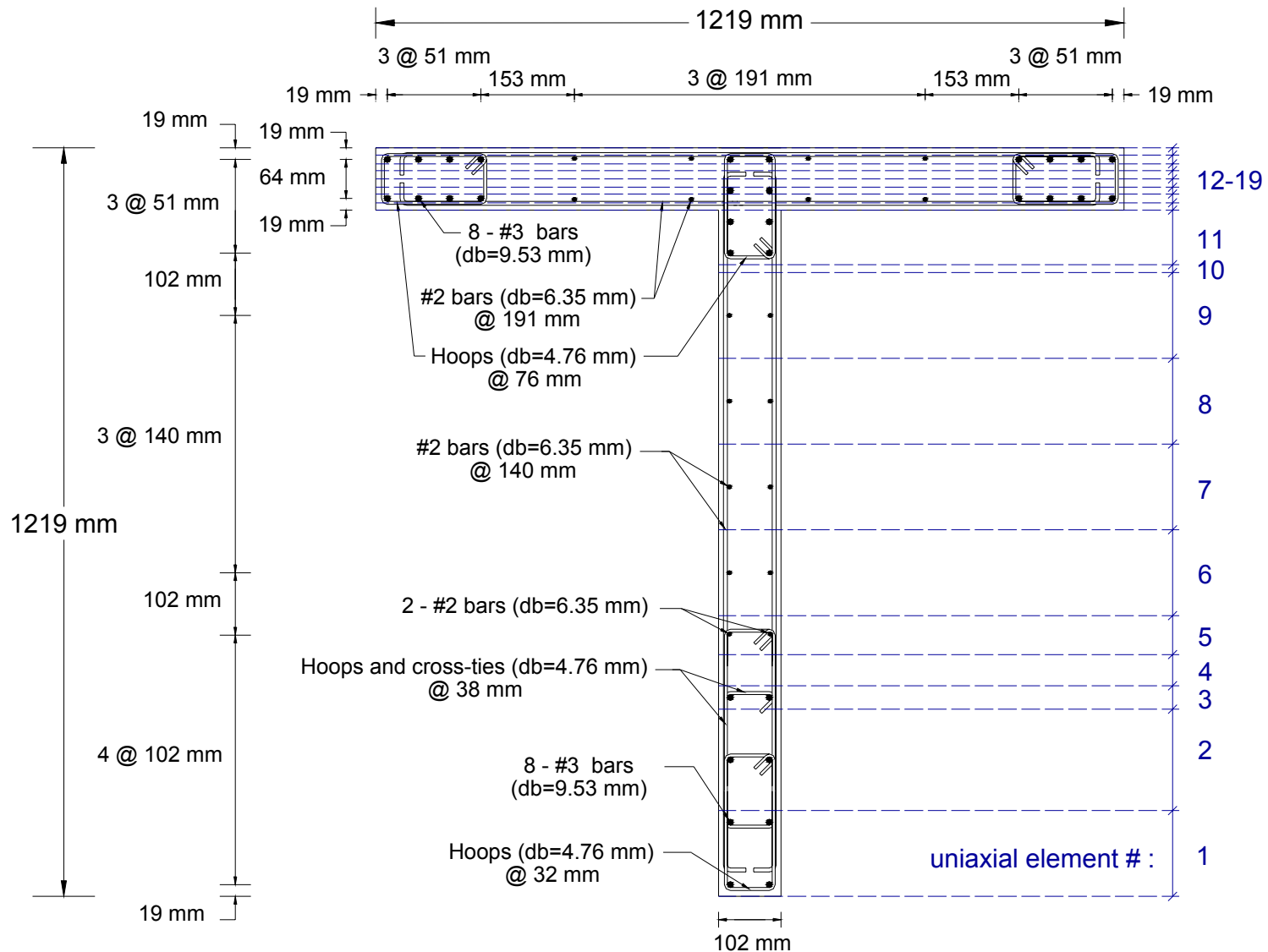

# Concrete Model - Unconfined

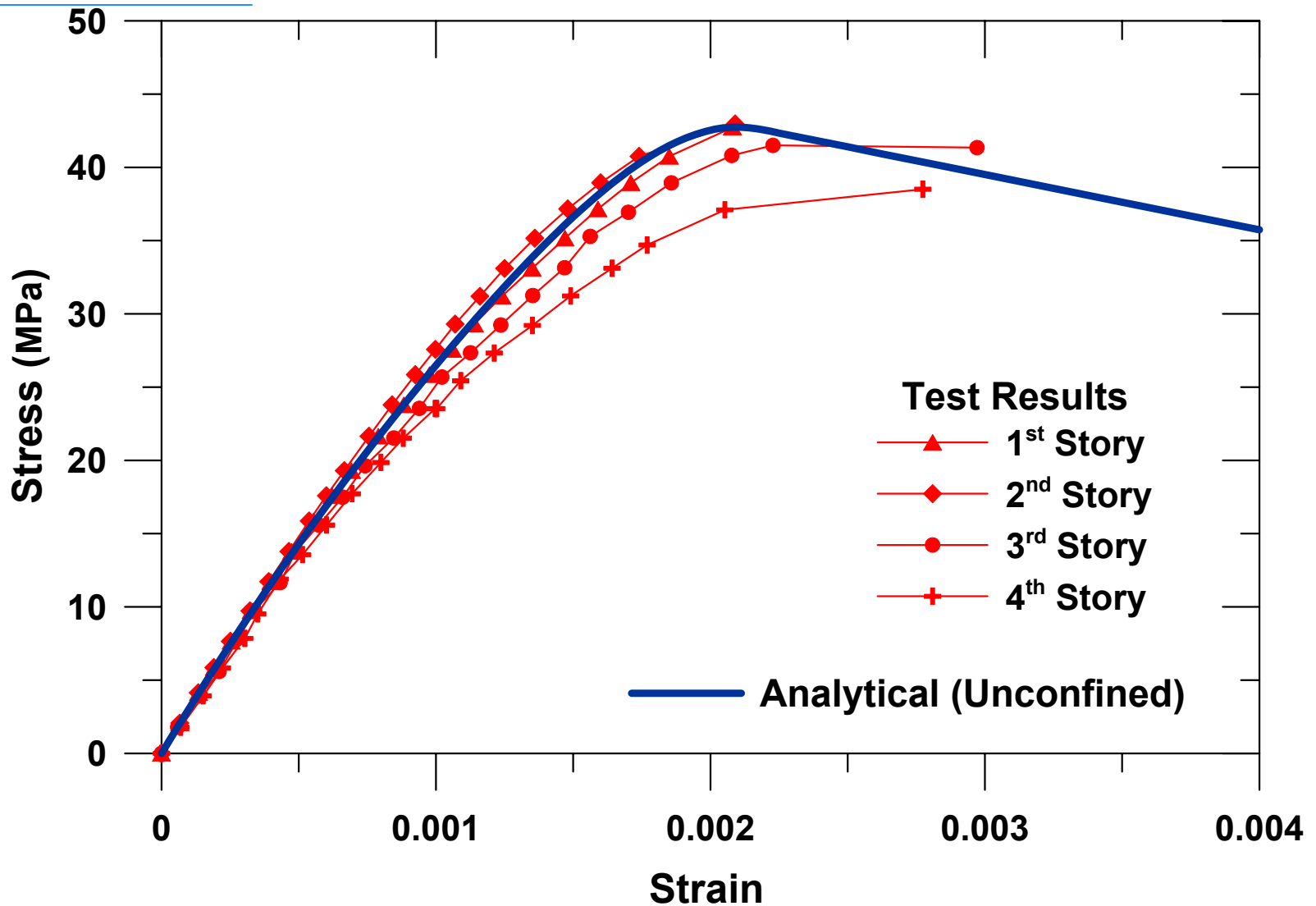

# Concrete Model - Confined

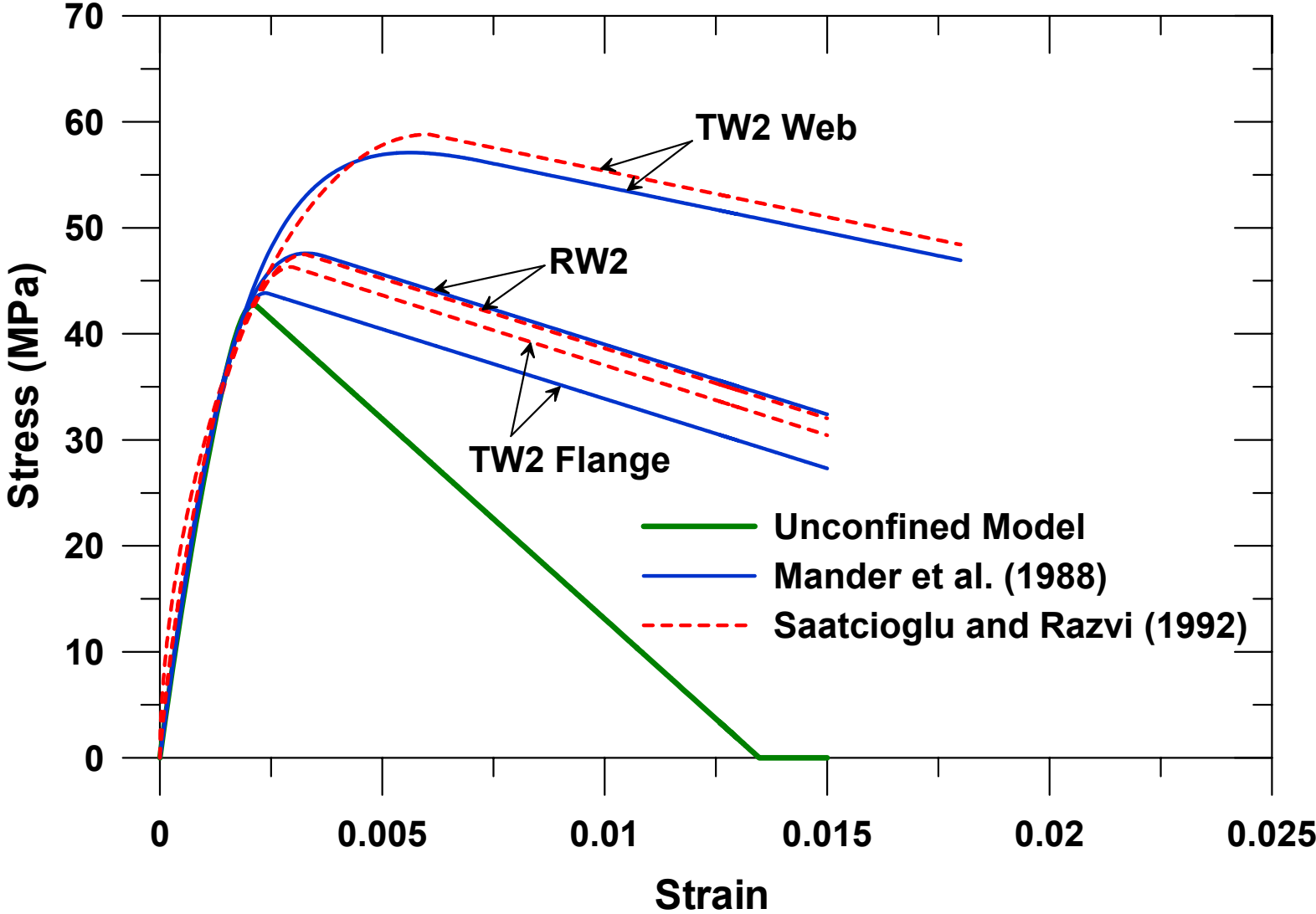

# Concrete Model - Tension

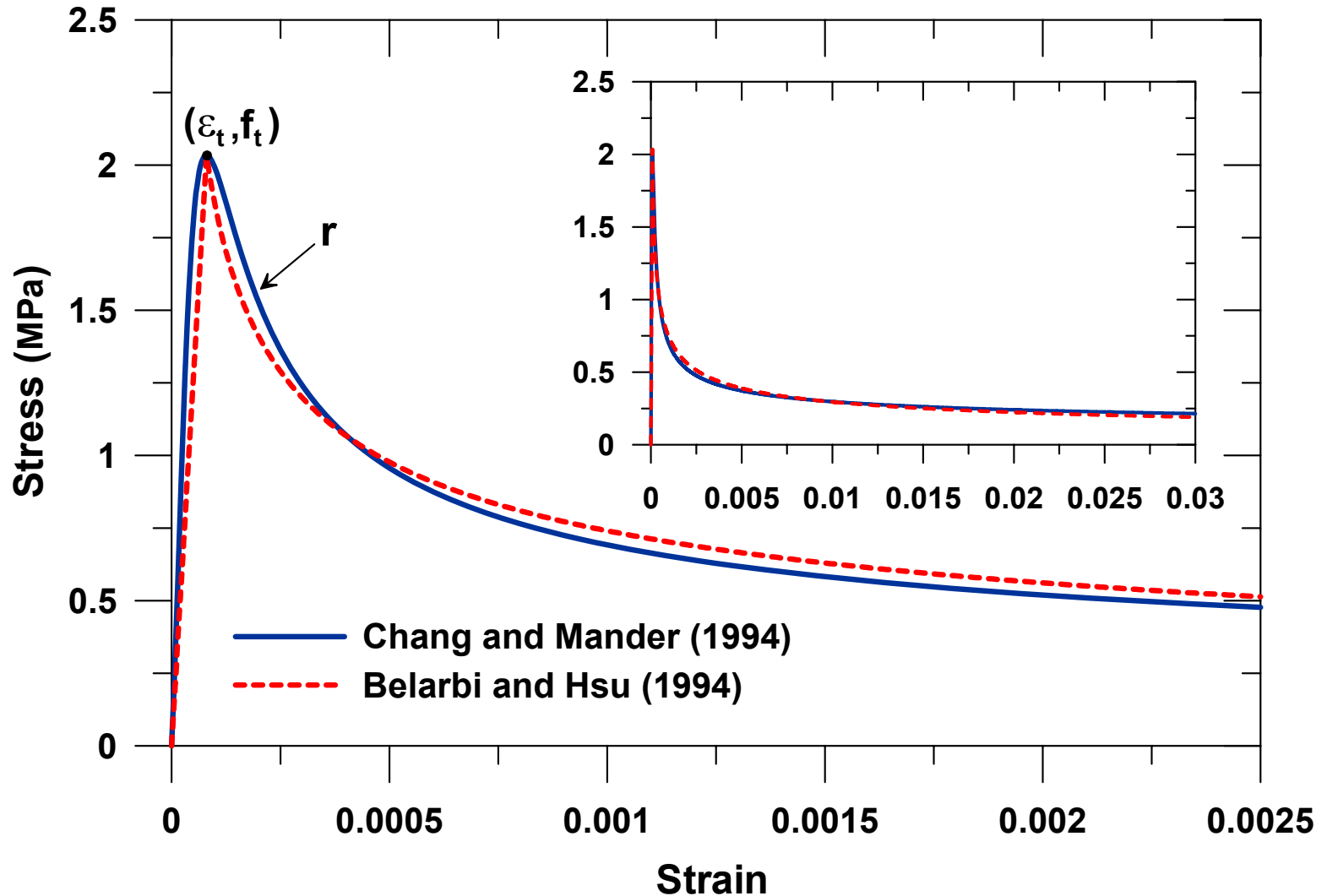

# Reinforcement Material Model

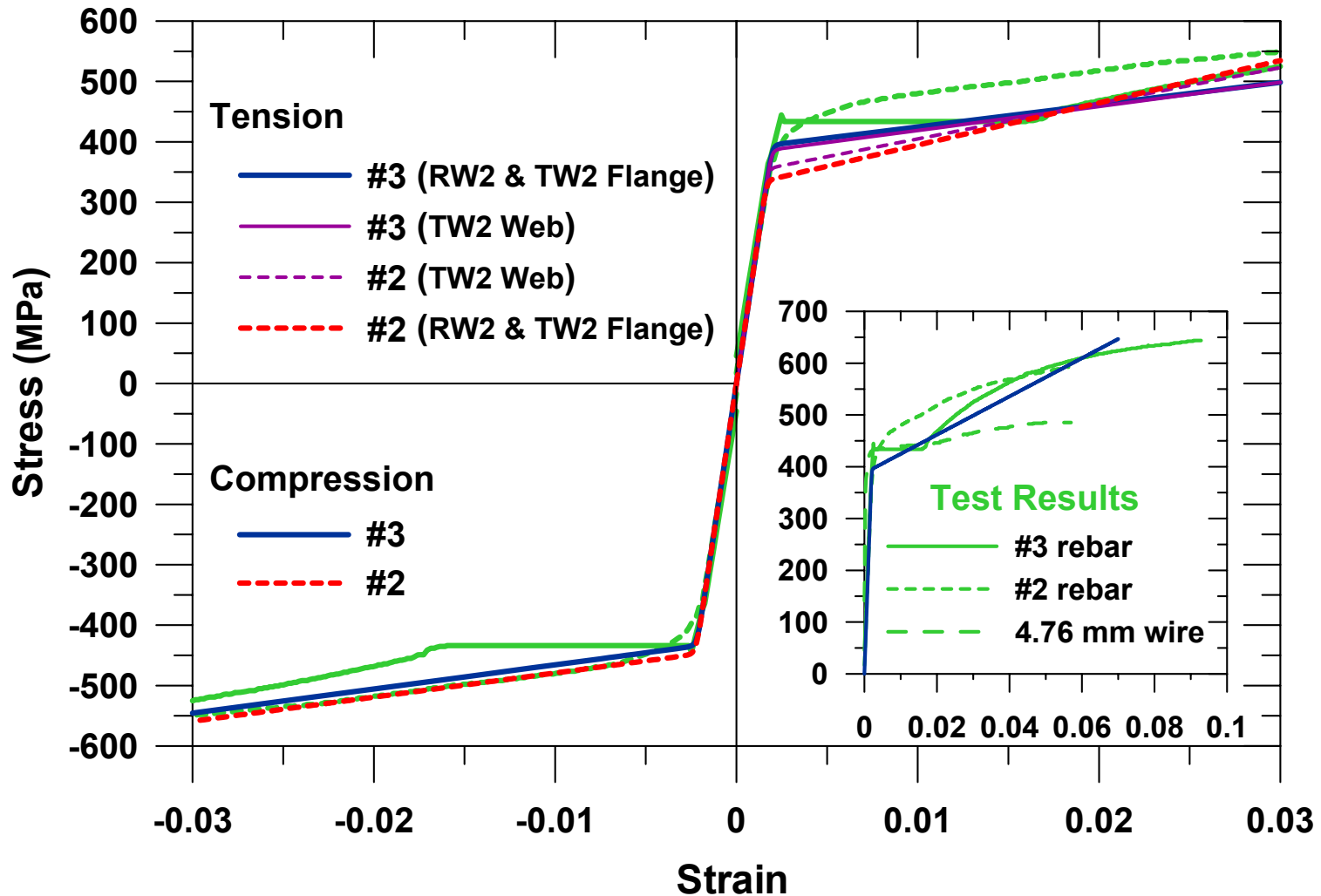

# Model Assessment – RW2

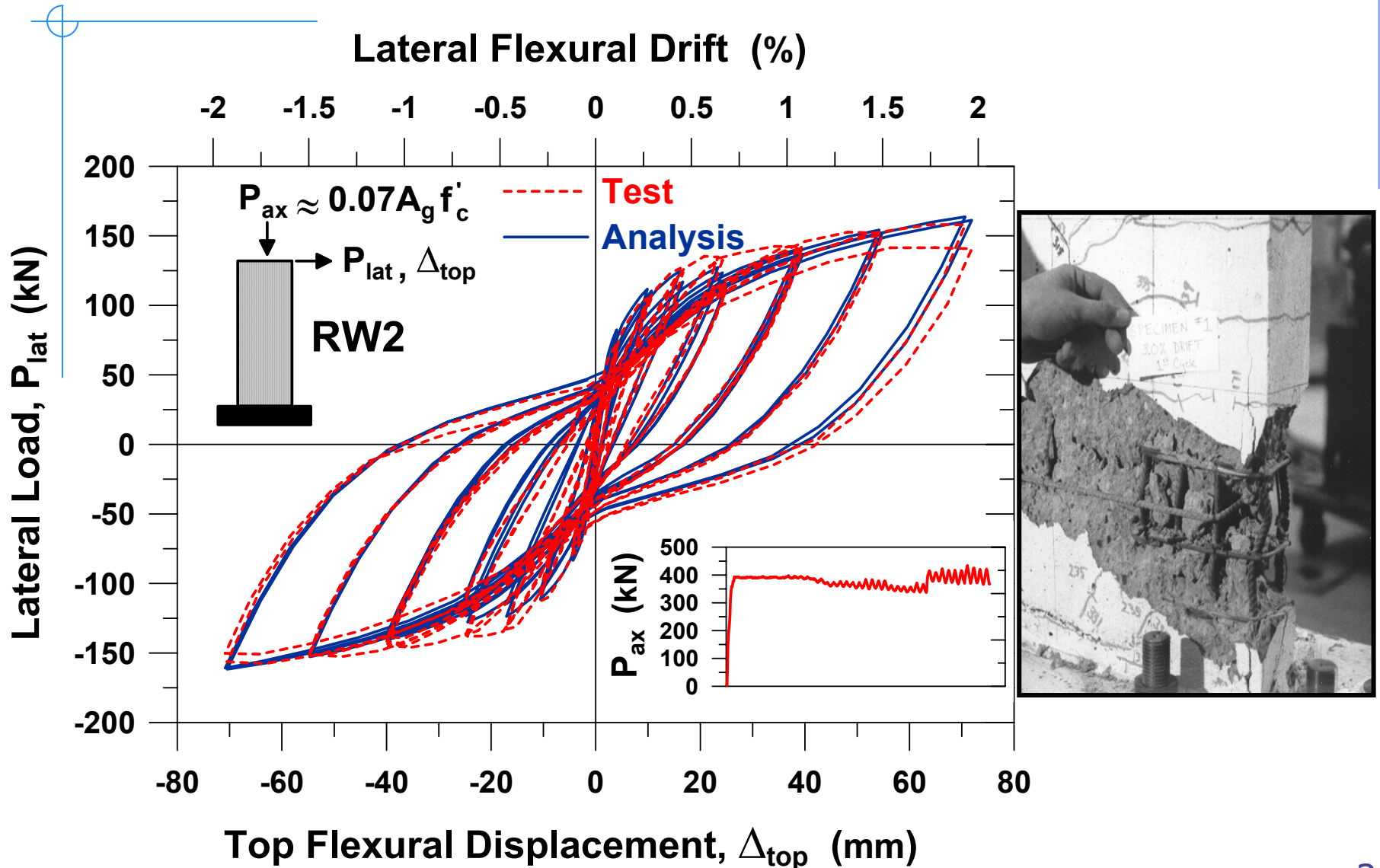

# Model Assessment – RW2

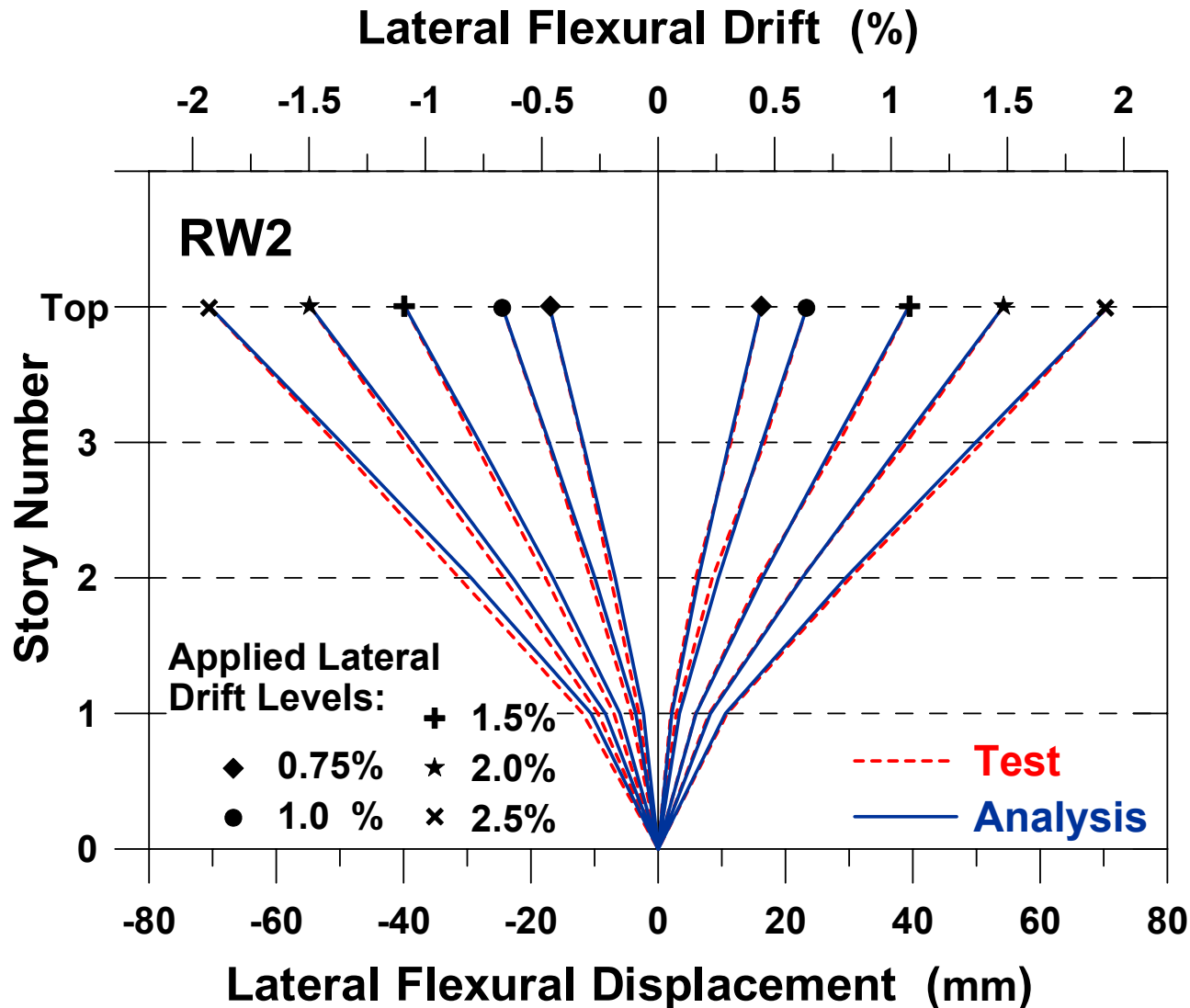

# Model Assessment – RW2

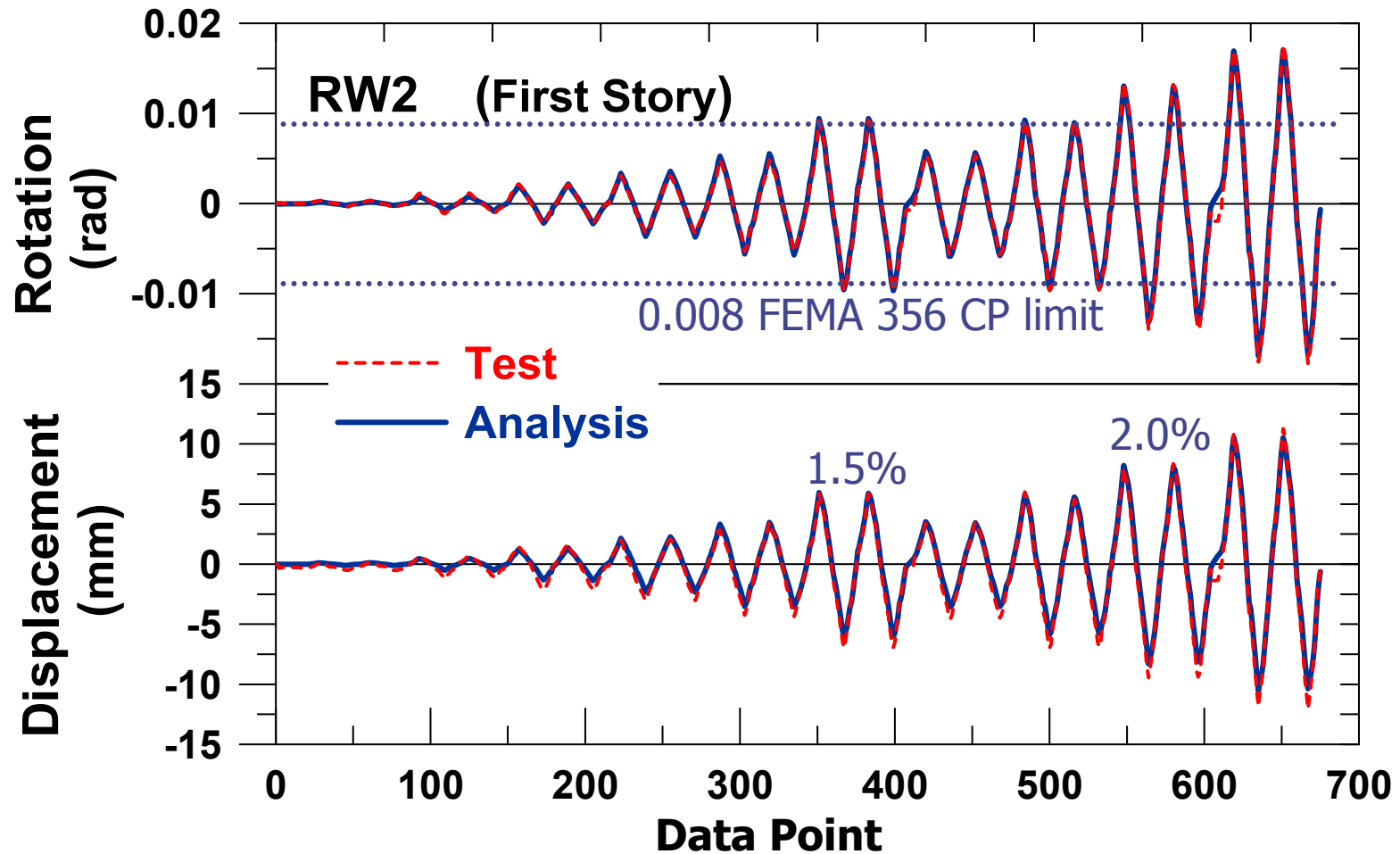

Results based on recommended values for material parameters; however, results could vary, maybe significantly, for different element lengths and material parameters (particularly if no strain hardening)

# Model Assessment – RW2

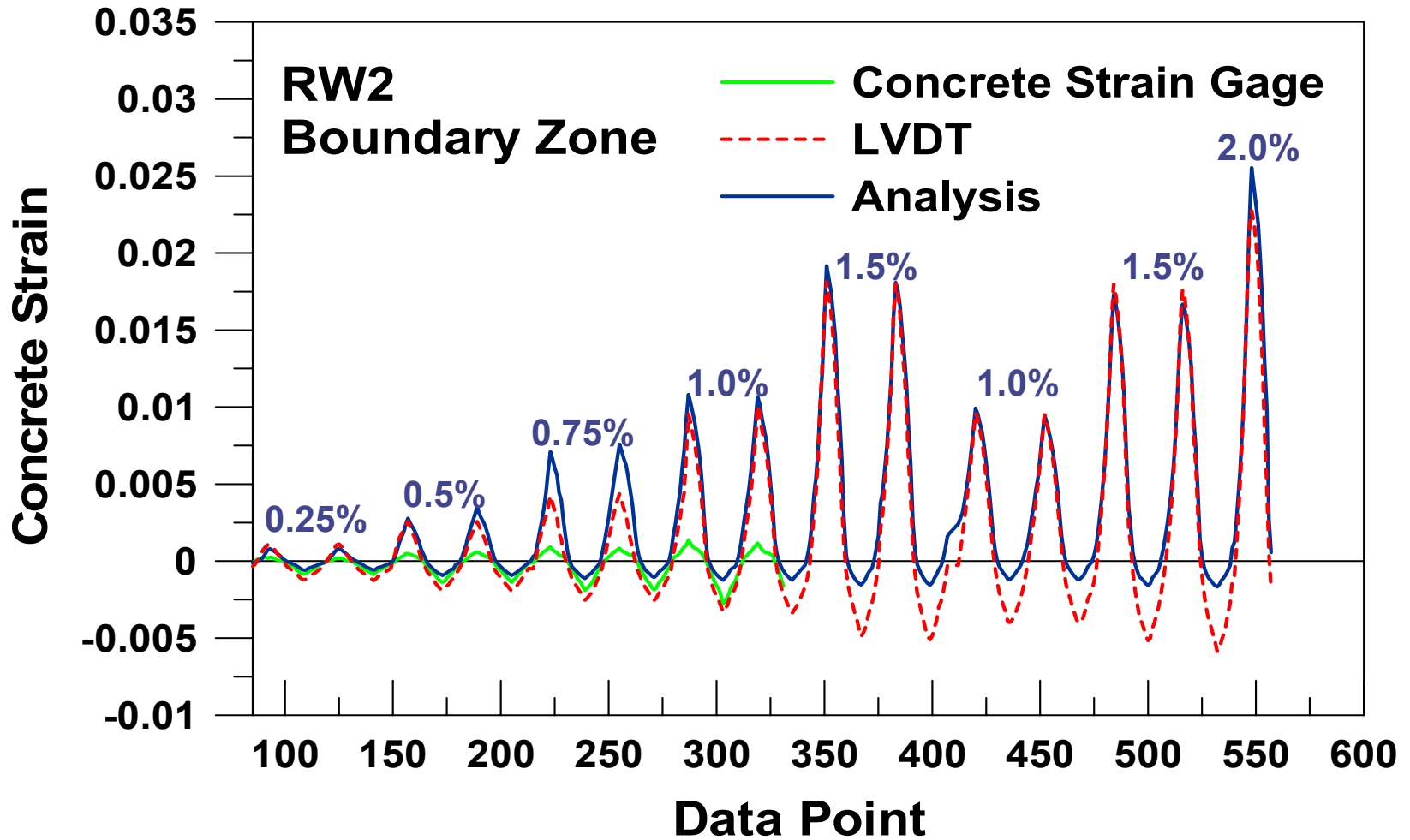

# t – RW2

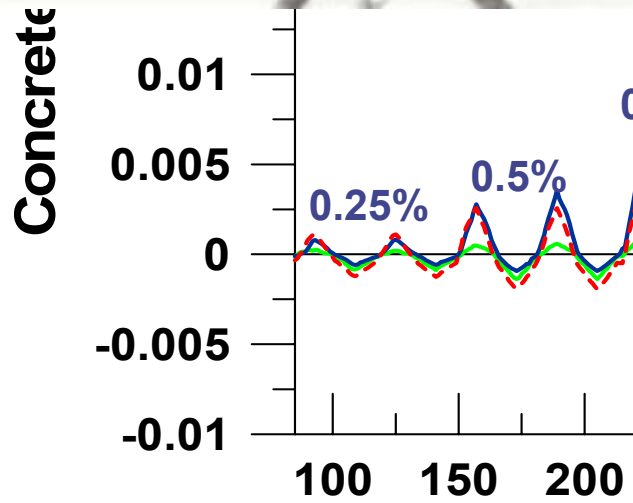
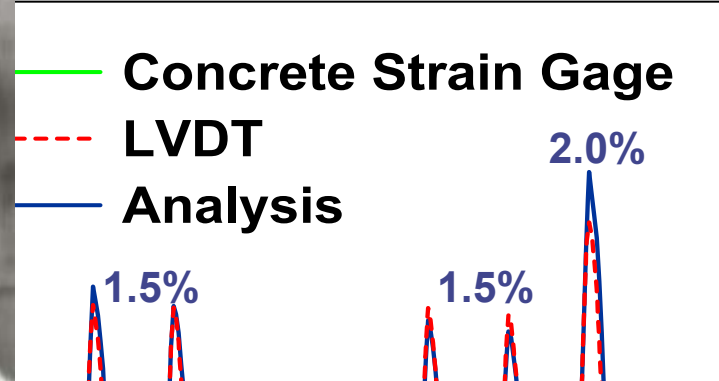

# Model Assessment – TW2

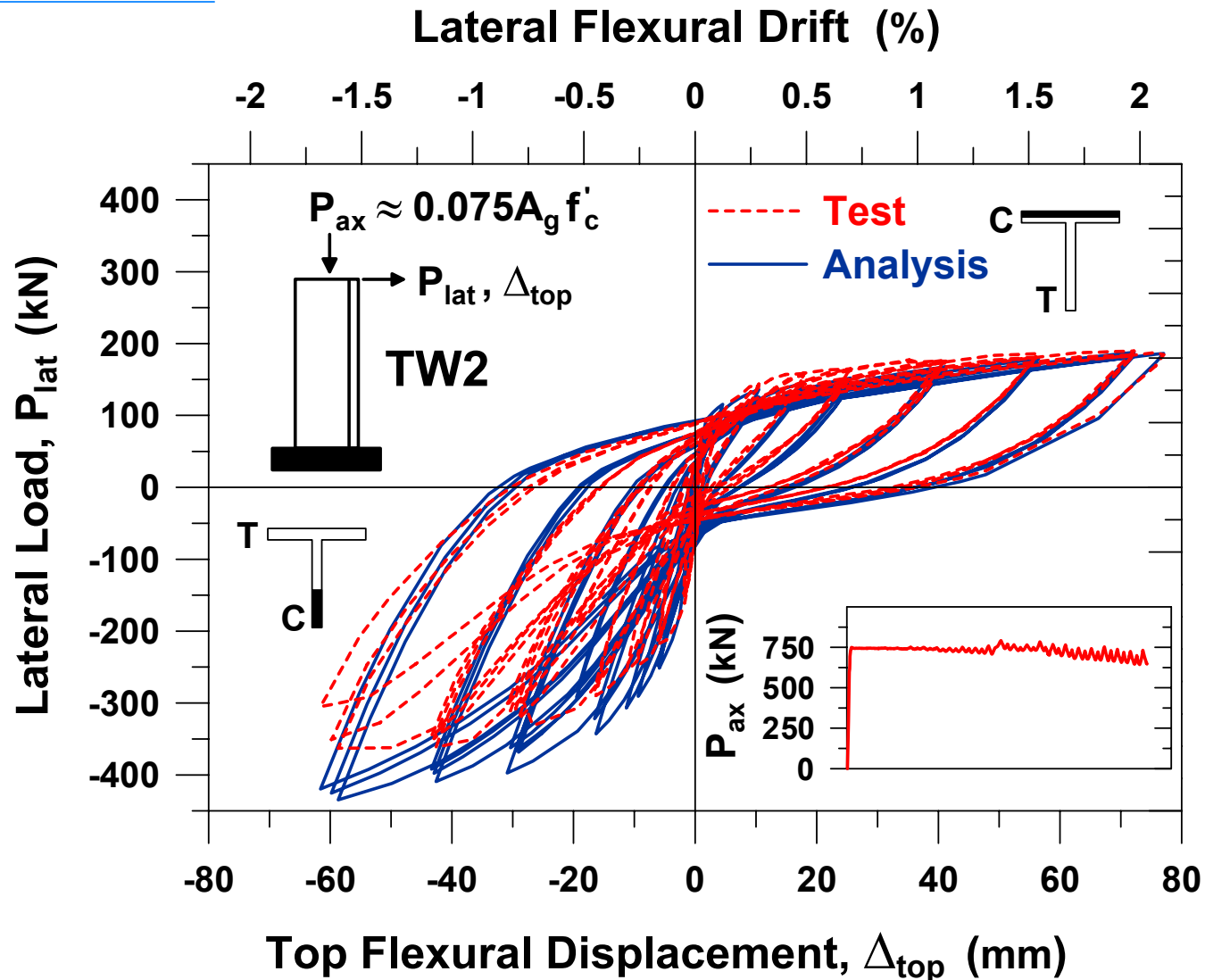

# Model Assessment – TW2

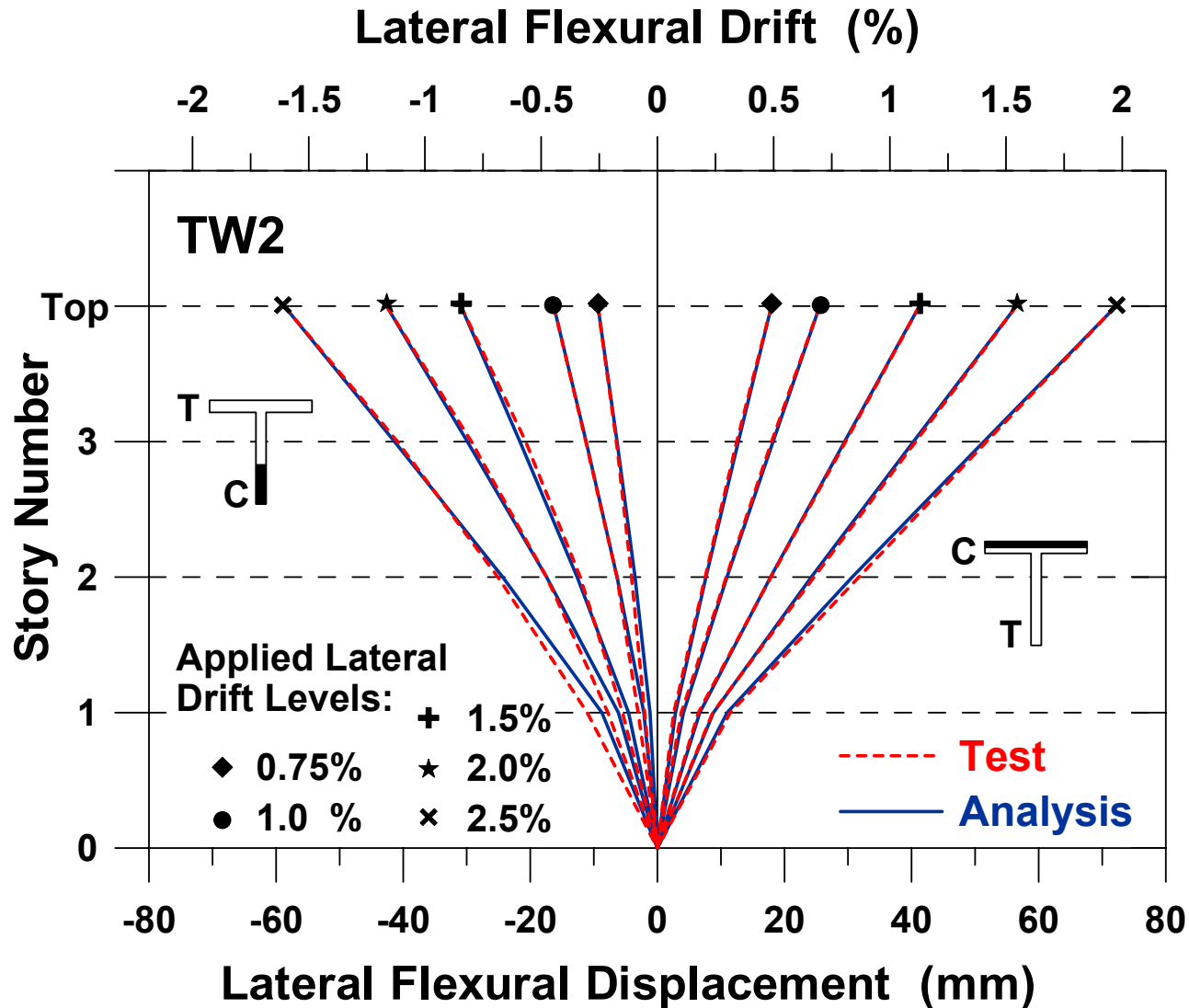

# Model Assessment – TW2

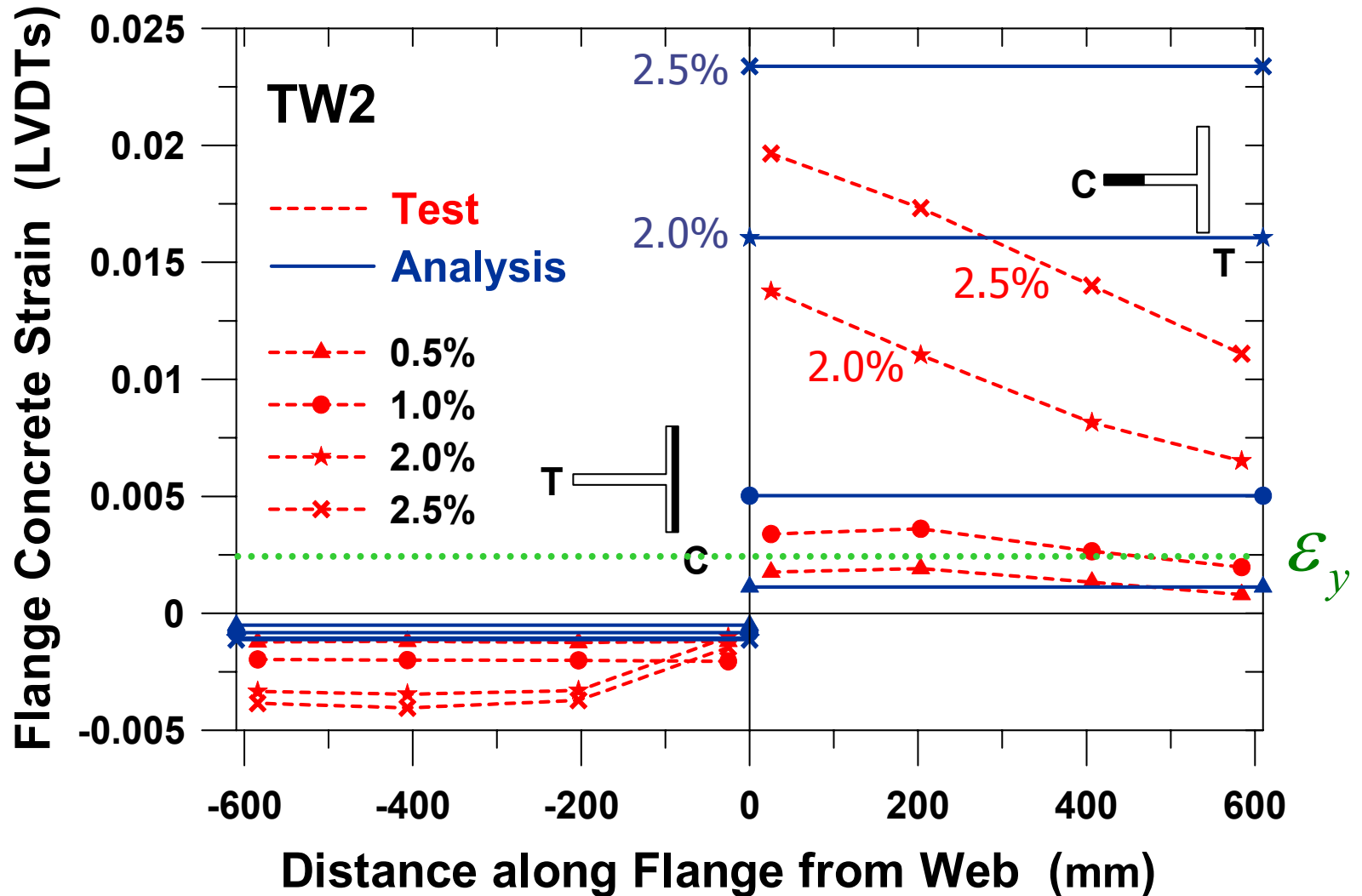

# Model Assessment – Stability

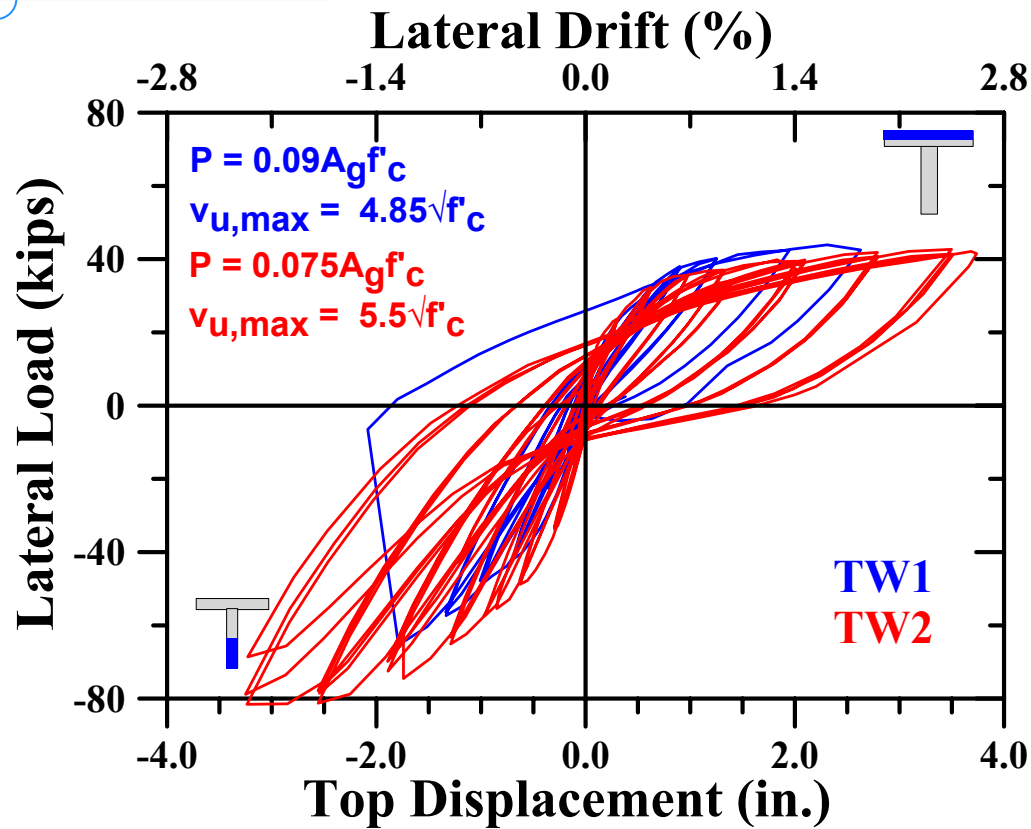

- TW1 – Abrupt failure due to buckling
- TW2 – Lateral instability due to spalling and large compression



# Model Assessment - Stability

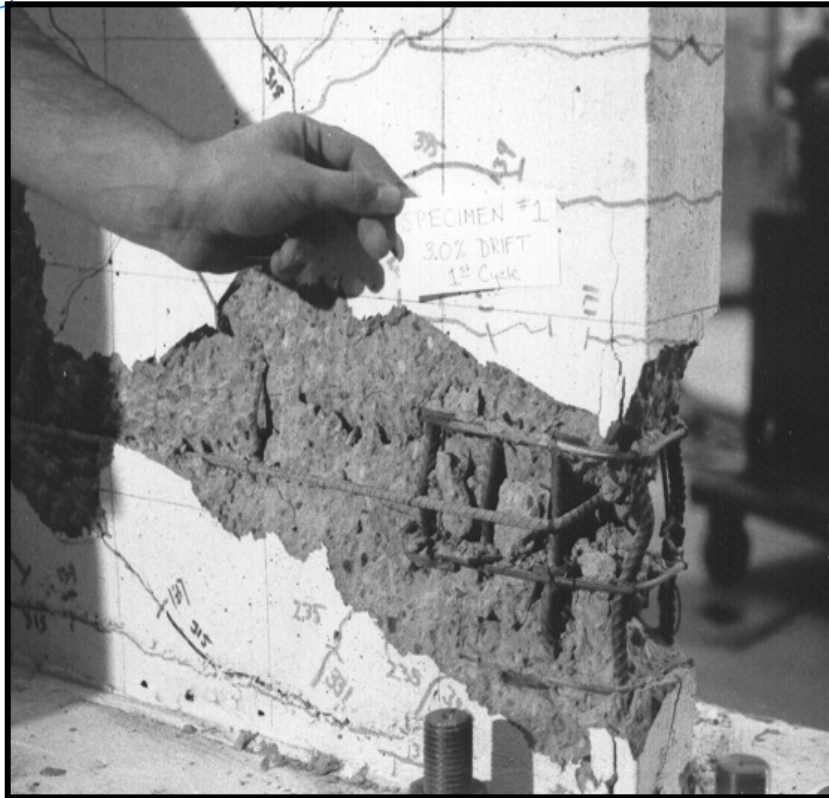

Rebar Buckling at Wall Boundary

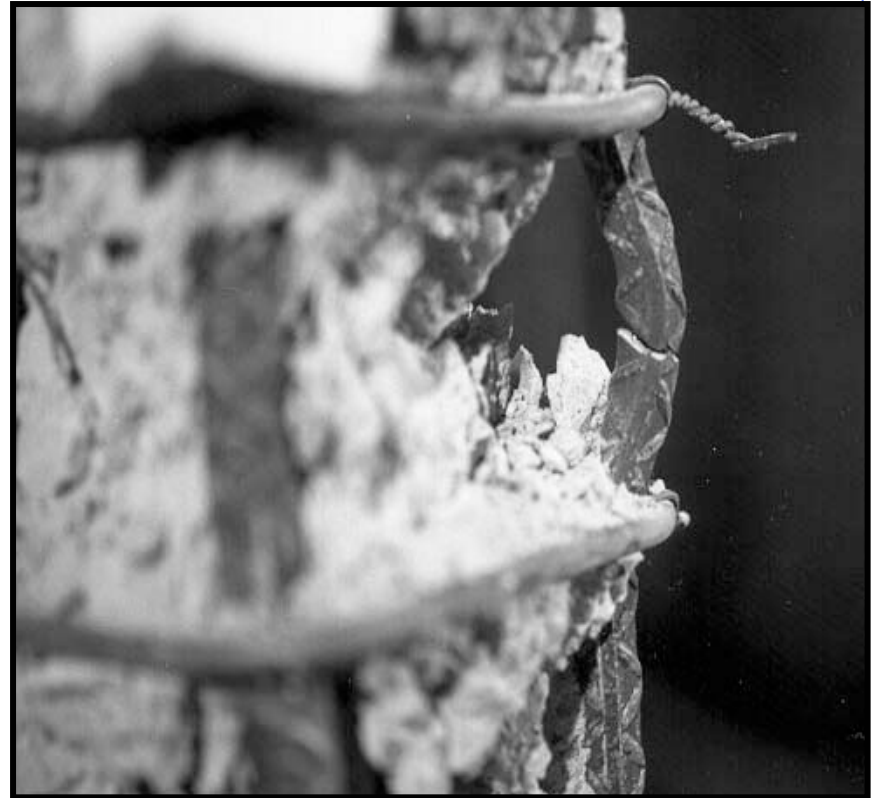

Rebar Fracture Following Buckling at Wall Boundary

Instabilities, such as rebar buckling and lateral web buckling, and rebar fracture are typically not considered in models; therefore, engineering judgment is required. Loss of lateral-load capacity does not necessarily mean loss of axial load capacity<sup>45</sup>

# FEMA 356 Table 6-18

**Table 6-18 Modeling Parameters and Numerical Acceptance Criteria for Nonlinear Procedures—Members Controlled by Flexure**

Conditions	Plastic Hinge Rotation (radians)		Residual Strength Ratio	Acceptable Plastic Hinge Rotation (radians)						
				Performance Level						
				IO	Component Type					
					Primary		Secondary <sup>4</sup>			
					LS	CP	LS	CP		
<b>i. Shear walls and wall segments</b>										
$\frac{(A_s - A'_s)f_y + P}{t_w l_w f'_c}$	$\frac{\text{Shear}}{t_w l_w \sqrt{f'_c}}$	Confined Boundary <sup>1</sup>								
≤ 0.1	≤ 3	Yes	0.015	0.020	0.75	0.005	0.010	0.015	0.015	0.020
≤ 0.1	≥ 6	Yes	0.010	0.015	0.40	0.004	0.008	0.010	0.010	0.015
≥ 0.25	≤ 3	Yes	0.009	0.012	0.60	0.003	0.006	0.009	0.009	0.012
≥ 0.25	≥ 6	Yes	0.005	0.010	0.30	0.0015	0.003	0.005	0.005	0.010
≤ 0.1	≤ 3	No	0.008	0.015	0.60	0.002	0.004	0.008	0.008	0.015
≤ 0.1	≥ 6	No	0.006	0.010	0.30	0.002	0.004	0.006	0.006	0.010
≥ 0.25	≤ 3	No	0.003	0.005	0.25	0.001	0.002	0.003	0.003	0.005
≥ 0.25	≥ 6	No	0.002	0.004	0.20	0.001	0.001	0.002	0.002	0.004

# FEMA 356 Table 6-18

			Plastic Hinge Rotation (radians)		Residual Strength Ratio
			a	b	c
<b>Conditions</b>					
<b>i. Shear walls and wall segments</b>					
$\frac{(A_s - A'_s)f_y + P}{t_w l_w f'_c}$	$\frac{\text{Shear}}{t_w l_w \sqrt{f'_c}}$	Confined Boundary <sup>1</sup>			
$\leq 0.1$	$\leq 3$	Yes	0.015	0.020	0.75
$\leq 0.1$	$\geq 6$	Yes	0.010	0.015	0.40
$\geq 0.25$	$\leq 3$	Yes	0.009	0.012	0.60
$\geq 0.25$	$\geq 6$	Yes	0.005	0.010	0.30

# FEMA 356 – Modeling Parameters

## WALL RW2:

$$A_s = A'_s \quad \& \quad P = 0.07 A_g f'_c \quad \& \quad \text{Hoops @ } 2'' \text{ o.c.}$$

$$2(0.027 \text{ in}^2) = 0.09(s)(h_c = 6'' + 3/8'' + 3/16'')(5 \text{ ksi} / 63 \text{ ksi})$$

$$s < 1.2'' \quad \text{Non-conforming}$$

## WALL TW2: Flange Compression

$$A_s = 8 - \#3 \quad A'_s = 10 - \#3 \text{ and } 4 - \#2 \quad f_y \approx 63 \text{ ksi} \quad \& \quad \text{Hoops/Ties @ } s=4''$$

No special detailing required: Conforming

$$\frac{(A_s - A'_s) f_y + P}{t_w l_w f'_c} = \frac{[-0.42 \text{ in}^2](63 \text{ ksi})}{4''(48'')(\sim 6 \text{ ksi})} + 0.075(2) = 0.127$$

$$\frac{V_u}{t_w l_w \sqrt{f'_c}} = \frac{40 \text{ kips}}{4''(48'')\sqrt{6000} / 1000} = 2.7$$

# FEMA 356 – Modeling Parameters

## WALL TW2: Flange Tension

$$A'_s = 8 - \#3 \ \& \ 2 - \#2 \quad A_s = 24 - \#3 \ \text{and} \ 8 - \#2 \quad \& \ f_y \approx 63 \text{ ksi}$$

Hoops/Ties @  $s=1.25''$  (5 legs and 2 legs)

$$5(0.027 \text{ in}^2) = 0.09(s)(h_c = 16'' + 3/8'' + 3/16'') (6 \text{ ksi} / 63 \text{ ksi}) \quad s < 1.0''$$

$$2(0.027 \text{ in}^2) = 0.09(s)(h_c = 2.5'' + 3/8'' + 3/16'') (6 \text{ ksi} / 63 \text{ ksi}) \quad s < 2.1''$$

~ Conforming

$$\frac{(A_s - A'_s) f_y + P}{t_w l_w f'_c} = \frac{[16(0.11) + 6(0.049)](63 \text{ ksi})}{4''(48'')(\sim 6 \text{ ksi})} + 0.075(2) = 0.26$$

$$\frac{V_u}{t_w l_w \sqrt{f'_c}} = \frac{80 \text{ kips}}{4''(48'')\sqrt{6000} / 1000} = 5.4$$

# FEMA 356 – Modeling Parameters

◆ Tables 6-18 (partial):

Walls Controlled by Flexure			Model Parameters, Radians		
$\frac{(A_s - A_s')f_y + P}{t_w l_w f_c}$	Conf. Bound.	$\frac{V}{t_w l_w \sqrt{f_c}}$	Plastic Hinge a	Plastic Hinge b	Residual Strength c
≤ 0.1	Yes	≤ 3	0.015	0.02	0.75
≤ 0.1	No	≤ 3	0.008	0.015	0.60
≥ 0.25	Yes	≥ 6	0.005	0.010	0.30
≥ 0.25	No	≥ 6	0.002	0.004	0.20

TW2  
Flange Comp  
RW2  
TW2  
Flange Tension

# FEMA Backbone Relation – RW2

$$P_{lateral} = \frac{M_n}{h_w} = 29.4 \text{ kips}$$

$$\delta_y = \left[ \frac{(P_{lateral} h_{load}^3)}{3E_c (0.5I_g)} \right]$$

$$= \frac{29.4^k (150'')^3}{3(4000^{ksi})(18,432^{in^4})} = 0.41''$$

$$\delta_a = 0.008(144'') = 1.15''$$

$$\delta_b = 0.015(144'') = 2.16''$$

$$P_{residual} = 0.6(29.4^k) = 17.6 \text{ kips}$$

# FEMA Backbone Relations – TW2

## Flange Compression

$$P_{lateral} = \frac{M_n}{h_w} = 40.2 \text{ kips}$$

$$\delta_y = \left[ \frac{(P_{lateral} h_{load}^3)}{3E_c (0.5I_g)} \right]$$
$$= \frac{40.2^k (150'')^3}{3(4400^{ksi})(40,700^{in^4})}$$
$$= 0.25''$$

$$I_g = 2.2(I_g)_{4x48} \quad \bar{y} = 34.5''$$

$$\delta_a = 0.015(144'') = 2.16''$$

$$\delta_b = 0.020(144'') = 2.88''$$

$$P_{residual} = 0.75(40.2^k) = 30.2 \text{ kips}$$

## Flange Tension

$$P_{lateral} = \frac{M_n}{h_w} = 77.0 \text{ kips}$$

$$\delta_y = \left[ \frac{(P_{lateral} h_{load}^3)}{3E_c (0.5I_g)} \right]$$
$$= \frac{77.0^k (150'')^3}{3(4400^{ksi})(40,700^{in^4})}$$
$$= 0.48''$$

$$I_g = 2.2(I_g)_{4x48} \quad \bar{y} = 34.5''$$

$$\delta_a = 0.005(144'') = 0.72''$$

$$\delta_b = 0.010(144'') = 1.44''$$

$$P_{residual} = 0.30(77.0^k) = 23.1 \text{ kips}$$

# Backbone Curve – RW2

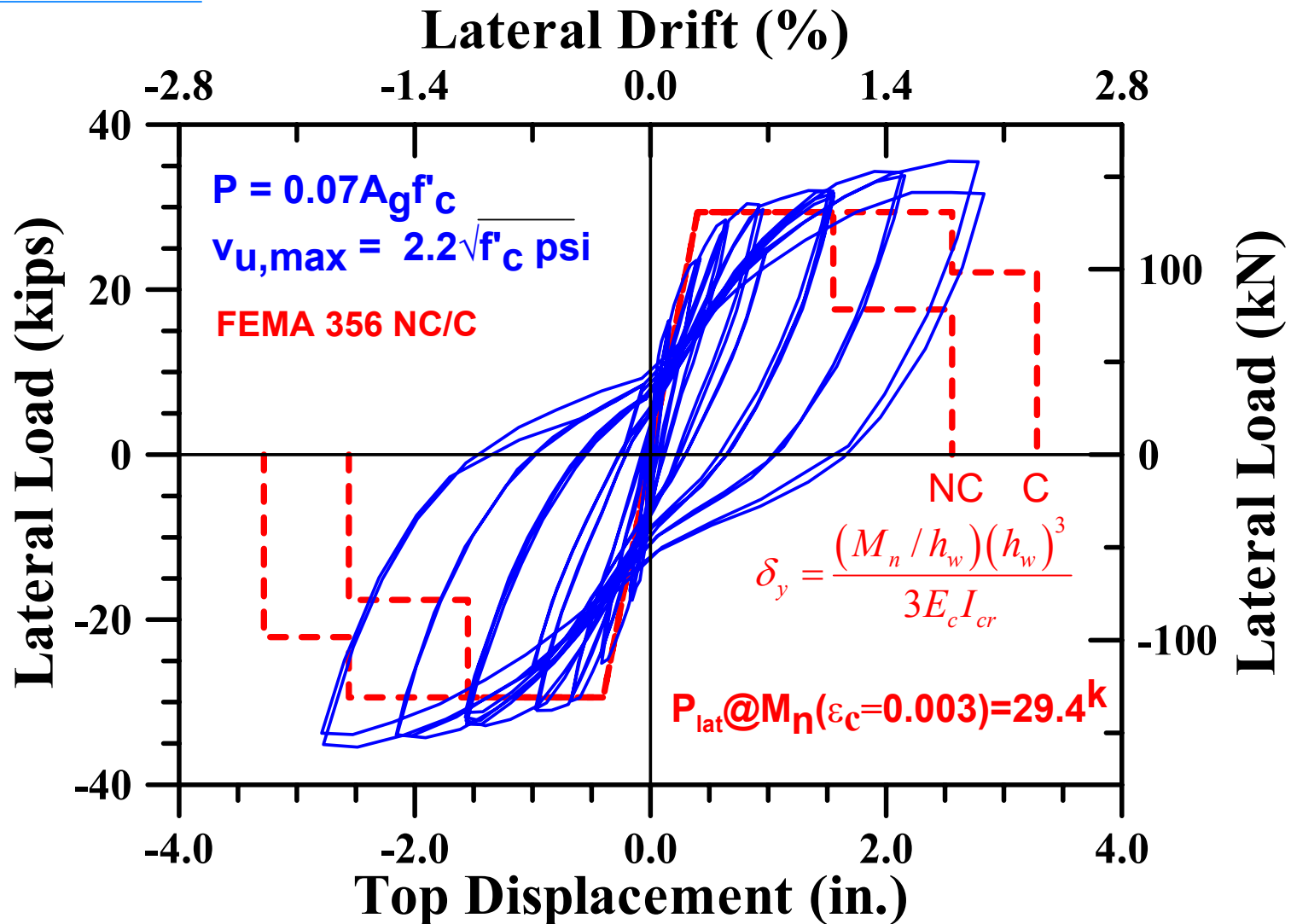

# Backbone Curve – TW2

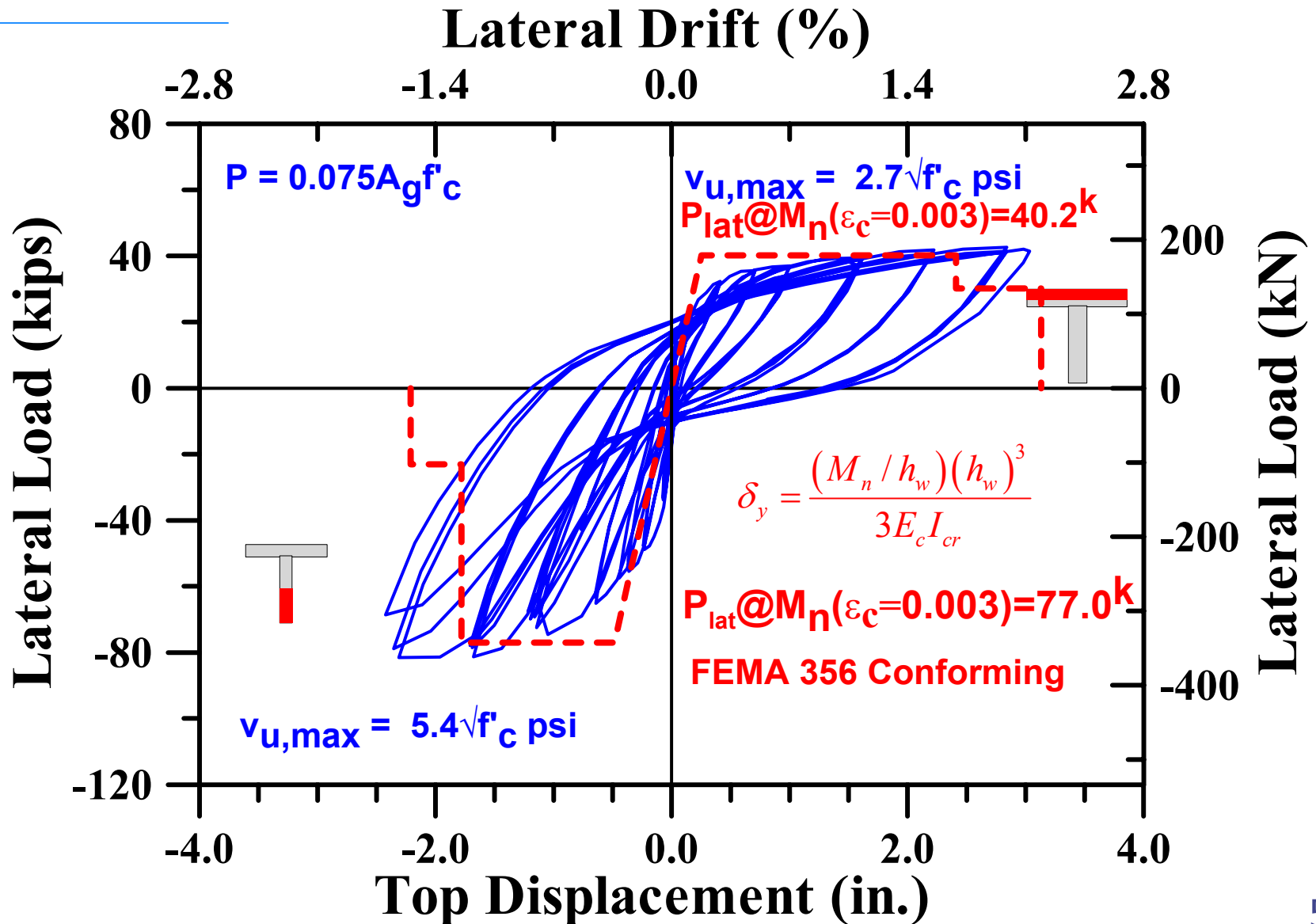

# Cantilever Wall Tests

Paulay, EERI, 2(4), 1986 [Goodsir, PhD 1985 NZ]

$h = 3.3 \text{ m}$   
 $= 10.83 \text{ ft}$

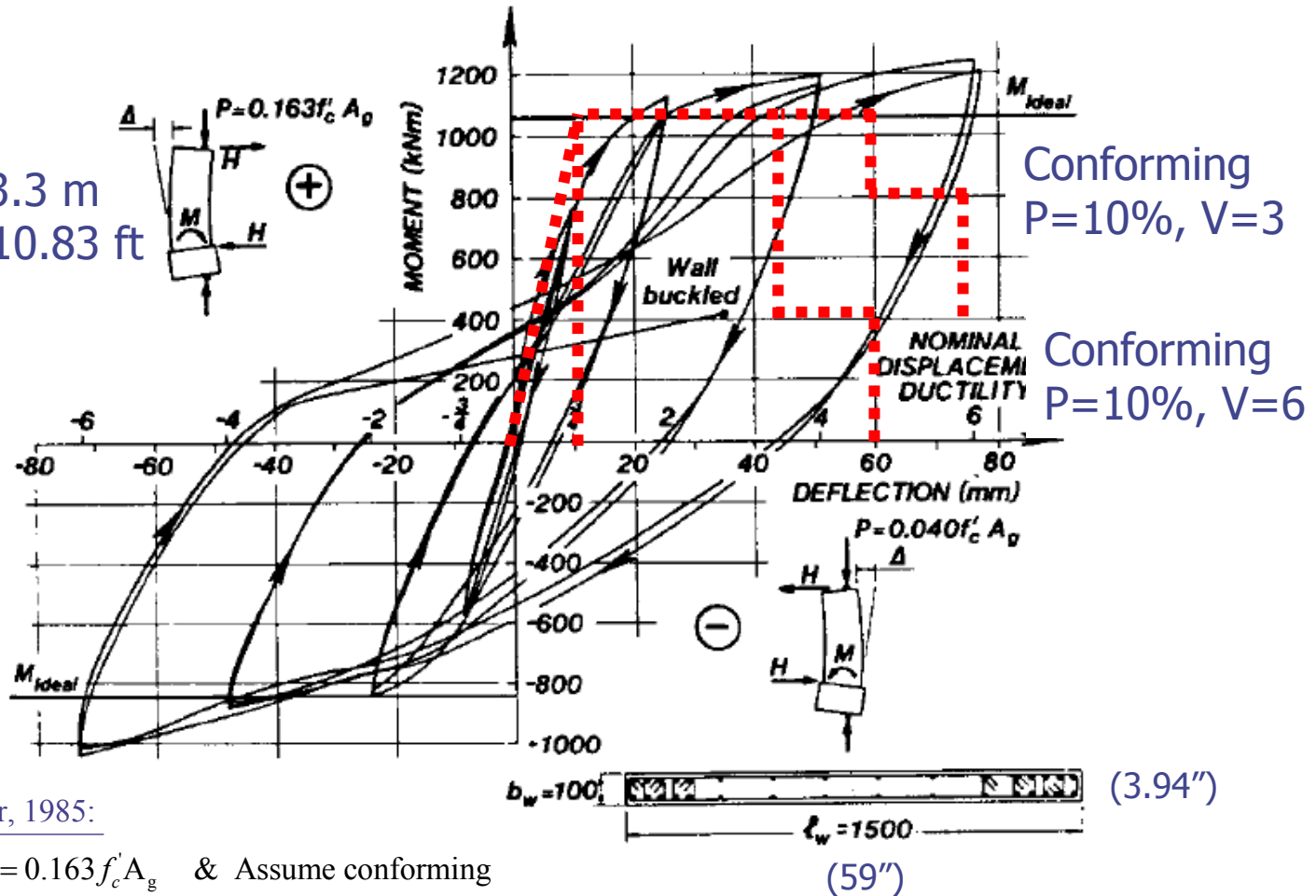

Conforming  
 $P=10\%, V=3$

Conforming  
 $P=10\%, V=6$

WALL Goodsir, 1985:

$A_s = A'_s$  &  $P = 0.163f'_c A_g$  & Assume conforming

$$\delta_y = \frac{PL^3}{3E_c 0.5I_g} = \frac{(70k)(130'')^3}{3(\sim 3750ksi)(0.5)(4'')(59'')^3 / 12} = 0.4'' \text{ (10.0mm)}$$

$$\frac{V_u}{t_w l_w \sqrt{f'_c}} = \frac{70k}{(4'')(59'')\sqrt{3750 \text{ psi}}} = 4.6$$

$$\delta_a \approx 0.01(3300\text{mm}) = 33\text{mm} \quad \delta_b \approx 0.015(3300\text{mm}) = 50\text{mm}$$

# Cantilever Wall Tests

Paulay, EERI, 2(4), 1986 [Goodsir, PhD 1985 NZ]

$h = 3.3 \text{ m}$   
 $= 10.83 \text{ ft}$

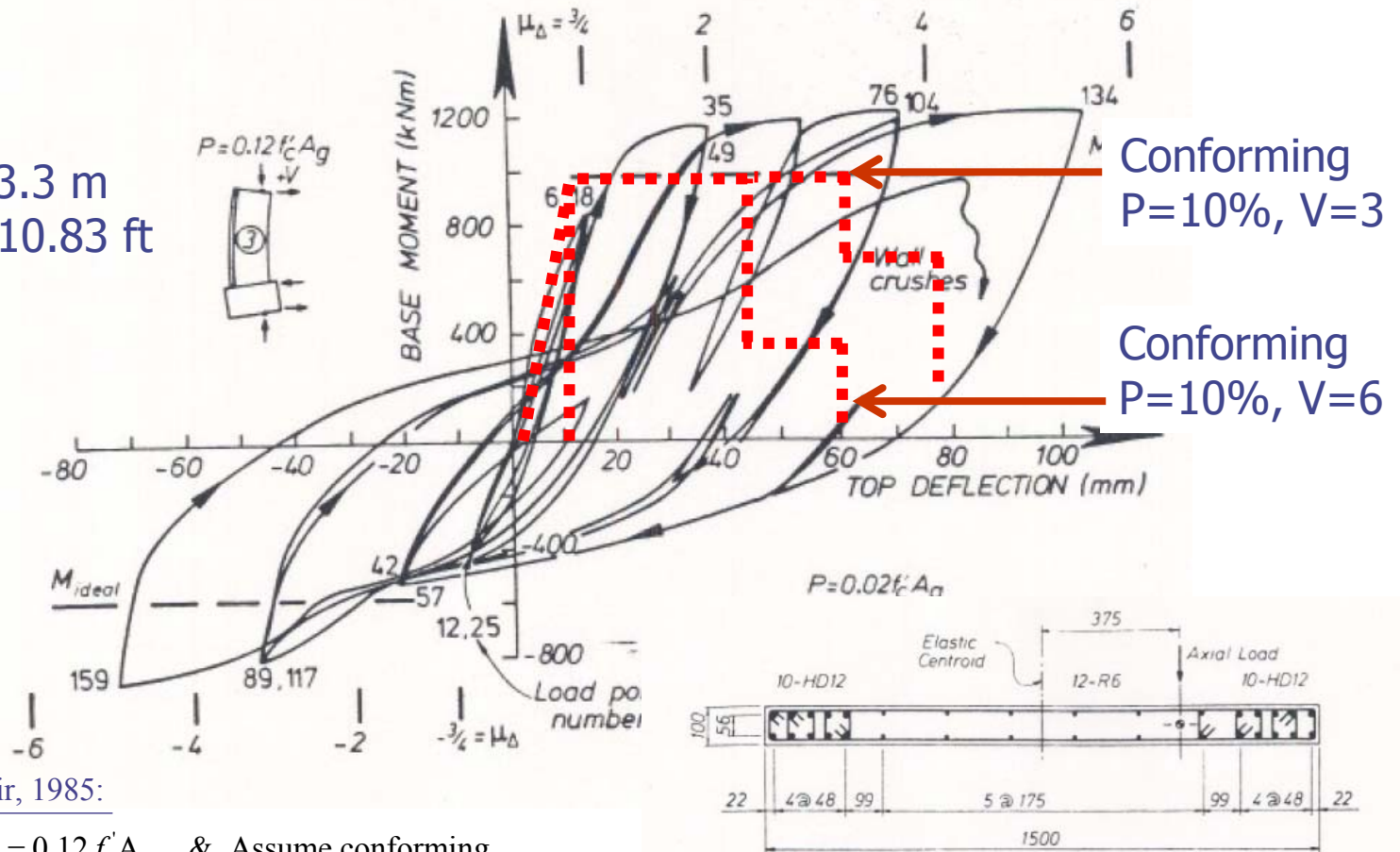

WALL Goodsir, 1985:

$A_s = A'_s$  &  $P = 0.12 f'_c A_g$  & Assume conforming

$$\delta_y = \frac{PL^3}{3E_c 0.5I_g} = \frac{(70k)(130'')^3}{3(\sim 3750 \text{ksi})(0.5)(4'')(59'')^3 / 12} = 0.4'' \text{ (10.0mm)}$$

$$\delta_a \approx 0.01(3300\text{mm}) = 33\text{mm} \quad \delta_b \approx 0.015(3300\text{mm}) = 50\text{mm}$$

$$\frac{V_u}{t_w l_w \sqrt{f'_c}} = \frac{70k}{(4'')(59'')\sqrt{3750 \text{psi}}} = 4.6$$

# Summary

## ◆ FEMA 356 Backbone Curves

- In general, quite conservative
- This appears to be especially true for cases where moderate detailing is provided around boundary bars
- Possible reformat
  - ◆ Compute neutral axis depth
  - ◆ If  $s < 12d_b$  over  $c/2$ , then modest ductility
  - ◆ If  $s < 8d_b$  and transverse steel ratio is  $\sim 1/2$  of ACI 318-05, then moderate ductility
  - ◆ If  $s < 8d_b$  and transverse steel ratio is  $> 3/4$  of ACI 318-05, then high ductility
  - ◆ Do not reduce deformation capacity for shear stress below 5 roots  $f'_c$

# Shear Design

## ◆ Wall shear studies

- Aktan & Bertero, ASCE, JSE, Aug. 1985
- Paulay, EERI 1996; Wallace, ASCE, JSE, 1994.
- Eberhard & Sozen, ASCE JSE, Feb. 1993

## ◆ Design Recommendations

- Based on  $M_{pr}$  at hinge region
- Uniform lateral force distribution

$$V_{wall} = \omega_v \left( \frac{M_{pr}}{M_u} \right) V_u \quad \omega_v = 0.9 + n / 10 \quad \text{Paulay, 1986}$$

$$V_{wall} = V_{limit} + (D_m = 0.3)(W = weight)(A_e = EPA) \quad \text{Eberhard, 1993}$$

# Slender Wall Behavior & Modeling



John Wallace

University of California, Los Angeles

With contributions from  
Dr. Kutay Orakcal  
University of California, Los Angeles

