



PACIFIC EARTHQUAKE ENGINEERING RESEARCH CENTER

Case Studies of the Seismic Performance of Tall Buildings Designed by Alternative Means

Task 12 Report for the Tall Buildings Initiative

**Jack Moehle, Yousef Bozorgnia,
Nirmal Jayaram, Pierson Jones, Mohsen Rahnama, Nilesh Shome,
Zeynep Tuna, John Wallace, Tony Yang, and Farzin Zareian**

Disclaimer

The opinions, findings, and conclusions or recommendations expressed in this publication are those of the author(s) and do not necessarily reflect the views of the study sponsor(s) or the Pacific Earthquake Engineering Research Center.

Case Studies of the Seismic Performance of Tall Buildings Designed by Alternative Means

Task 12 Report for the Tall Buildings Initiative

**Final Report to
California Seismic Safety Commission
under Contract No. SSC-2007-16
and
California Emergency Management Agency
under Contract No. FEMA-1628-DR-CA, OES-0005**

by

**Jack Moehle, Yousef Bozorgnia,
Nirmal Jayaram, Pierson Jones, Mohsen Rahnema, Nilesh Shome,
Zeynep Tuna, John Wallace, Tony Yang, and Farzin Zareian**

PEER Report 2011/05
Pacific Earthquake Engineering Research Center
College of Engineering
University of California, Berkeley
CSSC Report 11-02

July 2011

ACKNOWLEDGMENT

This report was completed to fulfill the final reporting requirements to the California Seismic Safety Commission under Contract No. SSC-2007-16 and California Emergency Management Agency under Contract No. FEMA-1628-DR-CA, OES-0005. These contracts provided financial support to conduct tall buildings case studies for testing the *Performance-Based Seismic Design Guidelines for Tall Buildings* developed under the *Tall Buildings Initiative* of the Pacific Earthquake Engineering Research Center, University of California, Berkeley. In addition to California Seismic Safety Commission and California Emergency Management Agency, Charles Pankow Foundation under Grant Agreement No. 03-07 also contributed to the development of case study building designs.

The *Tall Buildings Initiative* involved numerous interrelated tasks aimed at development of performance-based seismic design guidelines of tall buildings, including performance objectives, selection and scaling of earthquake ground motions, modeling and analysis guidelines, the recommended guidelines, and case studies. The work, including some of the work reported here, was made possible through financial and in-kind support by the following organizations: Applied Technology Council, California Emergency Management Agency, California Geologic Survey, California Seismic Safety Commission, Charles Pankow Foundation, City of Los Angeles, City and County of San Francisco, Federal Emergency Management Agency, Los Angeles Tall Buildings Council, National Science Foundation, Pacific Earthquake Engineering Research Center, Southern California Earthquake Center, Structural Engineers Association of California, and United States Geologic Survey. The tall building designs described in this report were developed with funding from the California Seismic Safety Commission, the California Emergency Management Agency, and Charles Pankow Foundation, and were completed by Magnusson Klemencic Associates (Seattle, WA), Simpson Gumpertz & Heger (San Francisco, CA), and Englekirk & Sabol Consulting Engineers (Santa Ana, CA). The analyses of these buildings were conducted using funding from the California Seismic Safety Commission, the California Emergency Management Agency, and City of Los Angeles. The contributions of these organizations are gratefully acknowledged.

Ali Sadre (Commissioner), Richard McCarthy (Executive Director), and Fred Turner (Structural Engineer) of the California Seismic Safety Commission provided expert guidance and project review.

The principal authors of this report were Jack Moehle and Yousef Bozorgnia (University of California, Berkeley), Tony Yang (University of British Columbia), Farzin Zareian and Pierson Jones (University of California, Irvine), John Wallace and Zeynep Tuna (University of California, Los Angeles), and Nilesh Shome, Nirmal Jayaram, and Mohsen Rahnama (Risk Management Solutions). Moehle and Bozorgnia were primarily responsible for Chapters 1 and 7; Zareian for Chapter 2; Yang and Moehle for Chapter 3; Wallace and Tuna for Chapter 4; Zareian and Jones for Chapter 5; and Yang, Shome, Jayaram, Rahnama, Moehle, and Bozorgnia for Chapter 6.

The opinions expressed are those of the authors and do not necessarily represent the views of any of the funding agencies, the Pacific Earthquake Engineering Research Center, or the University of California.

CONTENTS

ACKNOWLEDGMENT	iii
TABLE OF CONTENTS	v
LIST OF FIGURES	ix
LIST OF TABLES	xvii
1 INTRODUCTION	1
1.1 Background, Objective, and Scope.....	1
1.2 Tall Building Design Methodologies and Building Types Used in this Study	3
1.3 Report Outline.....	4
2 HAZARD ANALYSIS AND GROUND MOTION SELECTION.....	7
2.1 Background.....	7
2.2 Site Hazard Characterization	7
2.3 Record Selection Procedure	8
2.3.1 Record Selection and Modification for Design Purposes	8
2.3.2 Record Selection and Modification for Assessment Purposes.....	8
3 DESIGN AND PERFORMANCE OF BUILDING 1: CORE WALL ONLY STRUCTURAL SYSTEM.....	19
3.1 Introduction	19
3.2 Design of Building 1 Structural System	20
3.3 Development of the Structural Analysis Models for Building 1	25
3.4 Building 1 Analysis Results and Discussion.....	26
4. DESIGN AND PERFORMANCE OF BUILDING 2: CORE WALL / SPECIAL MOMENT FRAME DUAL STRUCTURAL SYSTEM	35
4.1 Introduction	35
4.2 Design of Building 2 Structural System	36
4.3 Development of the Structural Analysis Models for Building 2	40

4.3.1	Modeling of Building 2A.....	40
4.3.1.1	Core Wall Modeling.....	41
4.3.1.2	Coupling Beam Modeling.....	43
4.3.1.3	Moment Frame Beam Modeling.....	44
4.3.1.4	Moment Frame Column Modeling.....	44
4.3.1.5	Slab Modeling.....	45
4.3.1.6	Basement Wall Modeling.....	45
4.3.1.7	Damping.....	45
4.3.1.8	Masses.....	46
4.3.1.9	Modeling of Building 2B.....	46
4.4	Building 2: Analysis Results and Discussion	46
4.4.1	Overall Behavior.....	46
4.4.1.1	Building 2A.....	46
4.4.1.2	Building 2B.....	47
4.4.2	Core Shear Wall Behavior.....	54
4.4.2.1	Building 2A.....	54
4.4.2.2	Building 2B.....	64
4.4.3	Frame Behavior.....	71
4.4.3.1	Building 2A.....	71
4.4.3.2	Building 2B.....	73
4.4.3.3	Frame Contribution in the Dual System.....	75
4.4.4	Comparison of Building 2A and Building 2B.....	76
5	DESIGN AND PERFORMANCE OF BUILDING 3: BUCKLING-RESTRAINED BRACED FRAME STRUCTURAL SYSTEM.....	81
5.1	Introduction.....	81
5.2	Design of Building 3 Structural System.....	81
5.3	Development of the Structural Analysis Models for Building 3.....	89
5.4	Building 3 Analysis Results and Discussion.....	93
6	FINANCIAL LOSS ESTIMATION OF THE TBI TALL BUILDING CASE STUDIES.....	103
6.1	Introduction.....	103
6.2	Initial Construction Cost Estimates.....	104
6.3	Loss Estimates Based on Current State-of-Practice.....	105

6.3.1	Loss Estimation Methodology	106
6.3.2	Simulating EDPs at Each Performance Level, $dG(EDP \widehat{IM})$	107
6.3.3	Simulating <i>DM</i> Corresponding to EDP, $dG(DM EDP)$	109
6.3.4	Fragility Functions for Structural Subsystems.....	110
6.3.5	Fragility Functions for Nonstructural Drift-Sensitive Subsystems.....	110
6.3.6	Fragility Functions for Nonstructural Acceleration-Sensitive Subsystems.....	111
6.3.7	Correlation of Damage States	112
6.3.8	Simulation of <i>DV</i> Given <i>DM</i> , $dG(DV DM)$	112
6.3.9	Correlation between Random Variables	113
6.3.10	Development of Vulnerability Functions.....	113
6.3.11	Loss Results	114
6.3.12	Uncertainty in Loss Results	115
6.3.13	Summary of the State-of-the-Art Loss Estimation.....	116
6.3.14	Key Assumptions and Limitations of the State-of-the-Practice Loss Estimation	116
6.4	Loss Simulation Study: ATC-58 Approach.....	119
6.4.1	Introduction.....	119
6.4.2	Selection of the Performance Groups and Fragility Curves	119
6.4.3	Results of Loss Simulation	120
7	SUMMARY AND CONCLUSIONS.....	167
7.1	Summary.....	167
7.2	Conclusions.....	168
7.2.1	Seismic Hazard.....	168
7.2.2	Case Study Building Designs.....	168
7.2.3	Structural Performance of the Case Study Buildings.....	170
7.2.4	Financial Aspects of the Case Study Buildings	171
	REFERENCES.....	173

- APPENDIX A: DESIGN REPORT FOR BUILDING 1 -- CORE WALL ONLY
STRUCTURAL SYSTEM**
- APPENDIX B: DESIGN REPORT FOR BUILDING 2 -- CORE WALL / SPECIAL
MOMENT FRAME DUAL STRUCTURAL SYSTEM**
- APPENDIX C: DESIGN REPORT FOR BUILDING 3 -- BUCKLING-RESTRAINED
BRACED FRAME STRUCTURAL SYSTEM**
- APPENDIX D: PROGRAM COST MODEL FOR PEER TALL BUILDINGS STUDY**

LIST OF FIGURES

Figure 2.1	Location of TBI building in Southern California.	11
Figure 2.2	PSHA disaggregation for TBI buildings with 2475-year return period at 1.0 sec.	11
Figure 2.3	PSHA disaggregation for TBI buildings with a 2475-year return period at 2.0 sec.	12
Figure 2.4	PSHA disaggregation for TBI buildings with a 2475-year return period at 3.0 sec.	12
Figure 2.5	PSHA disaggregation for TBI buildings with a 2475-year return period at 4.0 sec.	13
Figure 2.6	PSHA disaggregation for TBI buildings with a 2475-year return period at 5.0 sec.	13
Figure 2.7	Spectrum compatible acceleration, velocity, and displacement histories for Set 1 (horizontal 1 component) matched to the design target response spectrum.	14
Figure 2.8	Comparison between the average modified spectrum compatible acceleration histories response spectrum for all 14 spectrum compatible histories and the target design response spectrum.	15
Figure 2.9	Comparison between the target spectrum, selected and scaled ground motion spectra, and median spectrum of selected and scaled ground motions for the SLE25 hazard level.	16
Figure 2.10	Comparison between the target spectrum, selected and scaled ground motion spectra, and median spectrum of selected and scaled ground motions for the SLE43 hazard level.	16
Figure 2.11	Comparison between the target spectrum, selected and scaled ground motion spectra, and median spectrum of selected and scaled ground motions for the DBE hazard level.	17
Figure 2.12	Comparison between the target spectrum, selected and scaled ground motion spectra, and median spectrum of selected and scaled ground motions for the MCE hazard level.	17
Figure 2.13	Comparison between the target spectrum, selected and scaled ground motion spectra, and median spectrum of selected and scaled ground motions for the OVE hazard level.	18
Figure 3.1	Isotropic view of the prototype building.	19
Figure 3.2	Plan view of the prototype building.	20
Figure 3.3	Steel reinforcement in the coupling beams.	24

Figure 3.4	Vertical steel reinforcement in the concrete core wall.....	24
Figure 3.5	Isotropic view of the analytical model.....	25
Figure 3.6	Comparison of the modal period.....	26
Figure 3.7	Sample response history at the SLE25 hazard level.	27
Figure 3.8	Sample response history at the SLE43 hazard level.	28
Figure 3.9	Sample response history at the DBE hazard level.	29
Figure 3.10	Sample response history at the MCE hazard level.....	30
Figure 3.11	Sample response history at the OVE hazard level.	31
Figure 3.12	Peak floor accelerations.	32
Figure 3.13	Peak interstory drift ratios.....	33
Figure 4.1	Three-dimensional building view.	35
Figure 4.2	5% damped code and site-specific design response spectra.	36
Figure 4.3	Coupling beam reinforcement details.	38
Figure 4.4	Serviceability level spectra.	38
Figure 4.5	Target acceleration response spectra at the MCE level.	39
Figure 4.6	Concrete stress-strain relationship.	41
Figure 4.7	Inelastic shear stress-strain relationship.....	42
Figure 4.8	Inelastic steel stress-strain relationship.....	43
Figure 4.9	Shear displacement hinge backbone curve.	43
Figure 4.10	Moment-rotation hinge backbone curve.	44
Figure 4.11	Rayleigh damping as defined by Perform-3D.	46
Figure 4.12	Building 2A: story displacements under various hazard levels.....	48
Figure 4.13	Building 2A: interstory drifts under various hazard levels.....	49
Figure 4.14	Building 2A: floor accelerations under various hazard levels.....	50
Figure 4.15	Building 2B: story displacements under various hazard levels.....	51
Figure 4.16	Building 2B: interstory drifts under various hazard levels.....	52
Figure 4.17	Building 2B: floor accelerations under various hazard levels.....	53
Figure 4.18	Elevation view of deformed wall segment.	55
Figure 4.19	Fragility curves for diagonally reinforced concrete coupling beams at high aspect ratio	55
Figure 4.20	Core wall shear forces under various hazard levels.	56
Figure 4.21	Average shear stress profiles of the core wall.....	57

Figure 4.22	Core wall shear forces under various hazard levels.	58
Figure 4.23	Locations of nodes used in strain calculations for the core wall.	59
Figure 4.24	North and South wall strains at the OVE level.	60
Figure 4.25	East and West wall strains at the OVE level.	61
Figure 4.26	Coupling beam locations.	62
Figure 4.27	Coupling beam rotations under various hazard levels.	63
Figure 4.28	Core wall shear forces under various hazard levels.	65
Figure 4.29	Average shear stress profiles of the core wall.	66
Figure 4.30	Core wall moments under various hazard level.	67
Figure 4.31	North and South wall strains at the OVE level.	68
Figure 4.32	East and West wall strains at the OVE level.	69
Figure 4.33	Coupling beam rotations under various hazard levels.	70
Figure 4.34	Frame beam rotations at the OVE level.	72
Figure 4.35	Absolute and normalized column axial forces at the OVE level.	72
Figure 4.36	<i>P-M</i> interaction diagram for South-West column at (a) ground floor; and (b) fifteenth floor.	73
Figure 4.37	Frame column rotations at the OVE level.	73
Figure 4.38	Frame beam rotations at the OVE level.	74
Figure 4.39	Absolute and normalized axial forces at the OVE level.	74
Figure 4.40	Frame column rotations at the OVE level.	75
Figure 4.41	Distribution of shear forces in the system at the OVE level: (a) Building 2A; and (b) Building 2B.	76
Figure 4.42	Comparison of interstory drifts (a) at the OVE level; and (b) at the SLE25 level.	77
Figure 4.43	Comparison of core shear stresses: (a) at the OVE level; and (b) at the SLE25 level.	77
Figure 4.44	Comparison of core wall strains at the OVE level.	78
Figure 4.45	Comparison of coupling beam rotations (a) at the OVE level; and (b) at the MCE level.	79
Figure 4.46	Comparison of frame beam rotations at the OVE level.	79
Figure 4.47	Comparison of normalized column axial forces at the OVE level.	80

Figure 5.1	Three-dimensional views of the structures used in the study: (a) the code based design, Building 3A; (b) the performance based design, Building 3B; and (c) the performance based plus design, Building 3C.....	83
Figure 5.2	Plan at ground floor and basement (subterranean) levels for Building 3A. Buildings 3B and 3C are similar. Box columns are shown as squares and the gravity columns are shown as W sections (I symbol). BRB bays are shown in red. The grey walls at the perimeter indicate the concrete basement walls. For the four subterranean levels, the walls are specified as 18 in. thick for the two highest and 24 in. thick for the two deepest.....	84
Figure 5.3	Plan of superstructure with three braced bays at grid lines 2 and 7. For Building 3A the plan corresponds to the first through tenth floors. For Building 3B the plan does not apply at all. For Building 3C the plan corresponds to the twentieth, thirtieth, and fortieth floors, which utilize outriggers. Box columns are shown as squares and the gravity columns are shown as W sections (I shaped). BRB bays are shown in red.	85
Figure 5.4	Plan of superstructure with single braced bay at grid lines 2 and 7. For Building 3A the plan corresponds to the eleventh through fortieth floors. For Building 3B the plan corresponds to the all of the floors (first through fortieth). For Building 3C the plan corresponds to all of the floors that do not include outriggers (hence the twentieth, thirtieth, and fortieth floors are excluded). Box columns are shown as squares and the gravity columns are shown as W sections (I shaped). BRB bays are shown in red.	86
Figure 5.5	Details showing elevations of BRB to gusset connections for a typical bay: (a) as specified for 301-500K strength BRB; (b) as specified for 501-800K strength BRB; and (c) as specified for 801-1200K strength BRB.....	87
Figure 5.6	Cross section of typical concrete filled box columns. The columns range in size from 18 in. × 57 in. square. Concrete used in the columns has a design strength of $f'_c=10,000$ psi.	88
Figure 5.7	Elevation of lateral load resisting frame along grid lines 2 and 7 (frame parallel to N-S direction). BRB strengths in kips are color coded per key: (a) The code based design, Building 3A; (b) the performance based design, Building 3B; and (c.) the performance based plus design, Building 3C.....	88
Figure 5.8	Modeling elements used in a typical BRB bay.....	91
Figure 5.9	General backbone curve for the nonlinear BRB element. The vertical axis represents force and the horizontal axis represents deformation. A_s = area of yielding steel core, $K_o = A_s E/L$, $E = 29,000$ ksi, $F_y=38$ ksi, $R_y = 1.1$, $\omega = 1.25$, $\beta = 1.1$, and $L =70\%$ of the brace length (using center-line to center-line geometry). Image courtesy of Dutta and Hamburger [2010].	91
Figure 5.10	Modal properties for Building 3A (buckling-restrained braced frame designed based on conventional codes).	92

Figure 5.11	Modal properties for Building 3B (buckling-restrained braced frame designed based on conventional codes).....	92
Figure 5.12	Modal properties for Building 3C (buckling-restrained braced frame designed based on conventional codes).....	93
Figure 5.13	Typical input motion and roof response: (a) 25-year return period hazard; and (b) 2045-year return period hazard.	96
Figure 5.14	Results for Building 3A (code-based design) in terms of maxIDR and resIDR.	97
Figure 5.15	Results for Building 3B (performance-based design) in terms of maxIDR and resIDR.	98
Figure 5.16	Results for Building 3C (code-based design) in terms of maxIDR and resIDR.	99
Figure 5.17	Peak floor acceleration variation along the height Building 3A in E-W and N-S directions at various hazard levels.....	100
Figure 5.18	Peak floor acceleration variation along the height Building 3B in E-W and N-S directions at various hazard levels.....	101
Figure 5.19	Peak floor acceleration variation along the height Building 3C in E-W and N-S directions at various hazard levels.....	102
Figure 6.1	Distribution of peak SDR and PFA and lognormal fit to the data at different levels of Building 2A for the MCE ground motion. The dotted line shows distribution of the EDPs when epistemic uncertainties are considered: (a) peak SDR in first story; (b) peak SDR in fortieth story; (c) PFA at second floor; and (d) PFA at forty-first floor.	108
Figure 6.2	Distribution over height of (a) median peakSDR and (b) PFA of Building 2A at various performance levels.	129
Figure 6.3	Distribution of standard deviation of logarithm of (a) peak SDR and (b) PFA of Building 2A at different performance levels.....	129
Figure 6.4	Correlation of peak SDR and PFA of Building 2A at different levels at MCE ground motion.	130
Figure 6.5	Mean fragility functions of different subsystems of buildings. Additionally some important component fragility functions are shown illustrating the relativity of the individual components; (a) extensive damage in dual-system structural subsystem; (b) extensive damage in nonstructural drift-sensitive subsystem; and (c) extensive damage in nonstructural acceleration-sensitive subsystem.	131
Figure 6.6	Fragility functions for suspended ceilings as developed by Aslani and Miranda and those defined in ATC-58 for different sizes and supports.....	132

Figure 6.7	Distribution of normalized cost of different subsystems of buildings: (a) structure; (b) non-structural drift; and (c) non-structural acceleration.	132
Figure 6.8	Contour of joint probability mass function of the normalized cost of structural (S), nonstructural drift-sensitive (NSD), and nonstructural acceleration-sensitive (NSA) subsystem of buildings.	133
Figure 6.9	Mean and the distribution of loss ratio of Building 2A at the five different performance levels as obtained from simulation.	133
Figure 6.10	Loss results of different code-designed buildings relative to the code-designed core wall building at different return periods.	134
Figure 6.11	Ratio of pure premium (average annual loss) of different code-designed structures to code-designed core wall structure.	134
Figure 6.12	Ratio of loss ratios of all the buildings at different return periods to the code-designed core-wall building.	135
Figure 6.13	Contributions to repair cost of different subsystems of dual-system building (Building 2A) at the SLE-43 and MCE performance levels.(i.e., at the low and high intensities of ground motion).	135
Figure 6.14	Distribution of repair cost over the height of Building 2A at the SLE-43 and MCE performance levels.....	136
Figure 6.15	Epistemic uncertainty in the loss results of various code-designed buildings relative to code-designed core-wall building due to 1-sigma (epistemic) uncertainty (or between 16% to 84% uncertainty) in the vulnerability functions.	136
Figure 6.16	Fragility curves for SW.	137
Figure 6.17	Fragility curve for SWBE.....	137
Figure 6.18	Fragility curves for LB.	138
Figure 6.19	Fragility curves for GC.....	138
Figure 6.20	Fragility curves for CW.....	139
Figure 6.21	Fragility curve for IP.	139
Figure 6.22	Fragility curve for elevator.....	140
Figure 6.23	Fragility curve for contents.....	140
Figure 6.24	Fragility curves for MRF	141
Figure 6.25	Fragility curves for the steel BRBs.....	141
Figure 6.26	Fragility curves for the ceiling in the steel building.	142
Figure 6.27	Repair cost distribution of Building 1A.....	142
Figure 6.28	Repair cost distribution of Building 1B.....	143
Figure 6.29	Repair cost distribution of Building 1C.....	143

Figure 6.30	Repair cost distribution of Building 2A.....	144
Figure 6.31	Repair cost distribution of Building 2B/2C.....	144
Figure 6.32	Repair cost distribution of Building 3A.....	145
Figure 6.33	Repair cost distribution of Building 3B.....	145
Figure 6.34	Repair cost distribution of Building 3C.....	146
Figure 6.35	Deaggregation of median repair cost for Building 1A at SLE25 hazard level.....	146
Figure 6.36	Deaggregation of median repair cost for Building 1A at SLE43 hazard level.....	147
Figure 6.37	Deaggregation of median repair cost for Building 1A at DBE hazard level.....	147
Figure 6.38	Deaggregation of median repair cost for Building 1A at MCE hazard level.....	148
Figure 6.39	Deaggregation of median repair cost for Building 1A at OVE hazard level.....	148
Figure 6.40	Deaggregation of median repair cost for Building 1B at SLE25 hazard level.....	149
Figure 6.41	Deaggregation of median repair cost for Building 1B at SLE43 hazard level.....	149
Figure 6.42	Deaggregation of median repair cost for Building 1B at DBE hazard level.....	150
Figure 6.43	Deaggregation of median repair cost for Building 1B at MCE hazard level.....	150
Figure 6.44	Deaggregation of median repair cost for Building 1B at OVE hazard level.....	151
Figure 6.45	Deaggregation of median repair cost for Building 1C at SLE25 hazard level.....	151
Figure 6.46	Deaggregation of median repair cost for Building 1C at SLE43 hazard level.....	152
Figure 6.47	Deaggregation of median repair cost for Building 1C at DBE hazard level.....	152
Figure 6.48	Deaggregation of median repair cost for Building 1C at MCE hazard level.....	153
Figure 6.49	Deaggregation of median repair cost for Building 1C at OVE hazard level.....	153
Figure 6.50	Deaggregation of median repair cost for Building 2A at SLE25 hazard level.....	154
Figure 6.51	Deaggregation of median repair cost for Building 2A at SLE43 hazard level.....	154
Figure 6.52	Deaggregation of median repair cost for Building 2A at DBE hazard level.....	155
Figure 6.53	Deaggregation of median repair cost for Building 2A at MCE hazard level.....	155
Figure 6.54	Deaggregation of median repair cost for Building 2A at OVE hazard level.....	156
Figure 6.55	Deaggregation of median repair cost for Building 2B/2C at SLE25 hazard level.....	156

Figure 6.56	Deaggregation of median repair cost for Building 2B/2C at SLE43 hazard level.....	157
Figure 6.57	Deaggregation of median repair cost for Building 2B/2C at DBE hazard level.....	157
Figure 6.58	Deaggregation of median repair cost for Building 2B/2C at MCE hazard level.....	158
Figure 6.59	Deaggregation of median repair cost for Building 2B/2C at OVE hazard level.....	158
Figure 6.60	Deaggregation of median repair cost for Building 3A at SLE25 hazard level.....	159
Figure 6.61	Deaggregation of median repair cost for Building 3A at SLE43 hazard level.....	159
Figure 6.62	Deaggregation of median repair cost for Building 3A at DBE hazard level.....	160
Figure 6.63	Deaggregation of median repair cost for Building 3A at MCE hazard level.....	160
Figure 6.64	Deaggregation of median repair cost for Building 3A at OVE hazard level.....	161
Figure 6.65	Deaggregation of median repair cost for Building 3B at SLE25 hazard level.....	161
Figure 6.66	Deaggregation of median repair cost for Building 3B at SLE43 hazard level.....	162
Figure 6.67	Deaggregation of median repair cost for Building 3B at DBE hazard level.....	162
Figure 6.68	Deaggregation of median repair cost for Building 3B at MCE hazard level.....	163
Figure 6.69	Deaggregation of median repair cost for Building 3B at OVE hazard level.....	163
Figure 6.70	Deaggregation of median repair cost for Building 3C at SLE25 hazard level.....	164
Figure 6.71	Deaggregation of median repair cost for Building 3C at SLE43 hazard level.....	164
Figure 6.72	Deaggregation of median repair cost for Building 3C at DBE hazard level.....	165
Figure 6.73	Deaggregation of median repair cost for Building 3C at MCE hazard level.....	165
Figure 6.74	Deaggregation of median repair cost for Building 3C at OVE hazard level.....	166

LIST OF TABLES

Table 1.1	Case studies buildings.....	4
Table 3.1	Element sizes.	22
Table 3.2	Structural material properties.....	23
Table 4.1	Period and mass participation summary.	36
Table 4.2	Period and mass participation summary.	39
Table 4.3	Cyclic degradation parameters.....	44
Table 6.1	Description of the models included in the seismic loss analyses.....	104
Table 6.2	Initial structural and content costs used for the ATC-58 loss estimation; in million U.S. dollars (*).	105
Table 6.3	Summary of the performance groups included in the loss analysis for Building 1.....	123
Table 6.4	Summary of the performance groups included in the loss analysis for Building 2.....	123
Table 6.5	Summary of the performance groups included in the loss analysis for Building 1.....	123
Table 6.6	Median repair cost in million U.S. dollars (SLE 25).	124
Table 6.7	Median repair cost in million U.S. dollars (SLE 43).	124
Table 6.8	Median repair cost in million U.S. dollars (DBE).	124
Table 6.9	Median repair cost in million U.S. dollars (MCE).	124
Table 6.10	Median repair cost in million U.S. dollars (OVE).	125
Table 6.11	Median repair cost normalized using initial construction cost (SLE 25).....	125
Table 6.12	Median repair cost normalized using initial construction cost (SLE 43).....	125
Table 6.13	Median repair cost normalized using initial construction cost (DBE).	125
Table 6.14	Median repair cost normalized using initial construction cost (MCE).	126
Table 6.15	Median repair cost normalized using initial construction cost (OVE).	126
Table 6.16	PML cost normalized using initial construction cost (SLE 25).	126
Table 6.17	PML normalized using initial construction cost (SLE 43).	126
Table 6.18	PML normalized using initial construction cost (DBE).	127

Table 6.19	PML normalized using initial construction cost (MCE).....	127
Table 6.20	PML normalized using initial construction cost (OVE).....	127
Table 6.21	Mean annualized repair cost.....	127
Table 6.22	Net present values of insurance premiums.....	128
Table 6.23	Total Cost + construction cost + net present value of insurance premiums.....	128
Table 6.24	Ratio of Total Costs.....	128

1 Introduction

1.1 BACKGROUND, OBJECTIVE, AND SCOPE

During the years 2000 through 2008 the western United States experienced a surge in the design and construction of tall buildings. Programmatic and economic demands resulted in many of these buildings being designed by a performance-based approach as an alternative to the prescriptive provisions of the building code. Project engineers, project reviewers, responsible jurisdictions, the research community, and other individuals and organizations with an interest in public safety recognized the need to develop guidance for these performance-based designs.

In April 2006 the Pacific Earthquake Engineering Research Center (PEER) of the University of California, Berkeley, formed the *Tall Buildings Initiative* as a research and development program to evaluate and advance the practice of performance-based seismic design of tall buildings. The program enlisted a wide range of stakeholder organizations and individuals to fund, manage, and conduct studies in support of the program. The Acknowledgment section of this report identifies the entities providing program support. Some agencies funded specific tasks along with specific deliverables, whereas others provided broader program support aimed at filling gaps that arose during the conduct of the multi-year program. The program was conducted by numerous individuals with expertise in engineering seismology, geotechnical engineering, structural engineering, and public policy, including researchers, practicing structural engineers, and building officials.

The objective of the *Tall Buildings Initiative* is to advance the practice of performance-based seismic design of tall buildings through a series of tasks aimed at understanding and gaining widespread acceptance of (a) performance objectives, (b) ground motion selection and modification for design, (c) modeling and analysis procedures, and (d) written guidelines for design and design review.

The scope of the *Tall Buildings Initiative* is seismic design of tall buildings, where tall buildings are considered those with (a) fundamental translational period of vibration significantly in excess of 1 second; (b) significant mass participation and lateral response in higher modes of vibration; and (c) slender aspect ratio of the seismic-force-resisting system. Buildings in Occupancy Category II as defined in Table 1-1 of ASCE 7.10, seismic hazard in the Western United States, and reinforced concrete and steel structures designed to resist strong earthquake motion through inelastic response of the structural components were targeted for study. Structural design for other than seismic resistance and design of nonstructural components and systems for seismic resistance are not within scope.

As part of the *Tall Buildings Initiative*, a set of guidelines for performance-based seismic design of tall buildings were developed [TBI 2010]. The Guidelines provide a unified approach for performance-based design and review of new tall buildings located in an area of high seismicity.

Additionally, a case study project also was conducted: three tall building systems (concrete core wall, concrete dual system, and a steel buckling restrained braced building) were designed by experienced practicing structural engineers. Three different sets of design criteria were used for each building. Expected performance of each building design was then studied using an analytical loss estimation technique.

As part of the program development, the *Tall Buildings Initiative Guidelines for Performance-Based Seismic Design of Tall Buildings*, and results of the building design case studies were presented in workshops in Los Angeles, San Francisco, and Seattle in 2010 and 2011, and by invitation to the Seismology Committee of the Structural Engineers Association of California in 2011.

This report focuses on the tall buildings case studies, i.e., those tasks supported through funding by the California Seismic Safety Commission and California Emergency Management Agency. The work involved probabilistic seismic hazard analysis and development of response spectra and scaled ground motions for design and analysis; design of three tall buildings and their structural systems, each according to three different criteria; analysis of the building designs using consistent modeling and analysis procedures; construction cost analysis; development of repair costs associated with damage for projected earthquakes; and iterations to improve the *Tall Buildings Initiative Design Guidelines*.

1.2 TALL BUILDING DESIGN METHODOLOGIES AND BUILDING TYPES USED IN THIS STUDY

In this study a series of tall buildings was designed for a building site located in Los Angeles at Longitude = -118.25, Latitude = 34.05; on a NEHRP site class C ($V_{S30} = 360$ m/sec). The site is surrounded by active faults: 1.5 km from Puente Hills fault, 7.3 km from Hollywood fault, 8.8 km from Raymond fault, 11.5 km from Santa Monica fault, 24.5 km from Elsinore fault, 40 km from Sierra Madre fault system, and 56 km from San Andres fault. Thus, the building hazard includes both near-field motions from moderate events and far-field motions from extreme events.

The study includes quantifying the seismic hazard and generating a series of representative ground motions by which to study building performance. Whereas most typical building designs consider one or two hazard levels—with the highest level representing 2% probability of exceedance in 50 years (2475-year return period) —this study was interested in understanding performance for a broader range of ground shaking hazard spanning a very frequent event (25-year return period) to a very rare shaking intensity (4975-year return period). Because of a shortage of recorded ground motions at the extreme hazard level, seismologists at the Southern California Earthquake Center (SCEC) at the University of Southern California were engaged to develop representative ground motions using simulation procedures.

To study the performance of tall buildings, a suite of tall buildings with a fundamental translational vibration period around 5 sec were selected. Three building types were investigated:

1. Reinforced concrete core-only with post-tensioned concrete gravity framing. This was one of the most common building types constructed during the recent construction surge.
2. Reinforced concrete core wall with concrete special moment frame (SMF) dual system. This system type is required by the prescriptive provisions of the building code for very tall buildings, but was less common during this construction surge.
3. Steel buckling-restrained braced frame system. Although this system type was less common, it was of interest to understand the design issues for buckling-restrained steel braced frames.

To achieve the desired vibration periods, the reinforced concrete buildings were designed to be 42 stories tall whereas the steel building was designed to be 40 stories tall. Each of the building configurations was designed according to (a) the building code prescriptive procedures, although it may have exceeded the height limit of the code; (b) the Los Angeles Tall Buildings Seismic Design Guideline [LATBSDC 2008] with slight modifications; and (c) the *Tall Buildings Initiative* [TBI 2010] draft guidelines. The table below summarizes the designs and their designations. Additional details are provided later in this report.

Table 1.1 Case studies buildings.

Building Type	Design Firm	Design Basis		
		Prescriptive Code	LATBSDC, 2008	TBI, 2010
Concrete core-only	Magnusson Klemencic Associates	1A	1B	1C
Concrete core with SMF	Englekirk Partners Consulting Structural Engineers, Inc.	2A	2B	2C
Steel buckling-restrained braced frame	Simpson Gumpertz & Heger	3A	3B	3C

1.3 REPORT OUTLINE

This report provides the details of various tasks of the tall buildings case studies, including ground shaking hazard, design and analysis of the buildings, and financial loss estimations due to various postulated earthquake hazards. The report is organized as follows:

Chapter 2 presents the seismic hazard analysis and ground motion selection procedures along with information on the selected records for the Los Angeles site.

Chapter 3 presents design and performance information for Building 1, including the design of the structural system, analytical modeling, and summary of response results. Chapters 4 and 5 repeat this presentation for Buildings 2 and 3.

Chapter 6 presents data on initial construction costs as well as results of two independently conducted loss estimation studies to project repair costs for anticipated future earthquakes.

Chapter 7 presents a summary and conclusions from the overall work presented in this report.

Appendices A, B, and C present the design reports developed by the structural engineering firms that developed designs for the case studies buildings. Appendix D provides the initial construction cost of each design, estimated by a professional cost estimator firm.

2 Hazard Analysis and Ground Motion Selection

2.1 BACKGROUND

Ground motion records were used in both the design and assessment phases of this research for the purpose of nonlinear dynamic analysis of the model buildings. Such an approach may provide a better understanding about the behavior of the structural system in contrast with using nonlinear static analysis (that is, pushover analysis) in which the model of the structural system with a predefined load pattern is pushed to a target deformation. Developing an appropriate set of ground motions to represent a target hazard level is an art, and one can utilize various methods. In this research, various implementations of the spectral matching and amplitude scaling methods for developing the ground motions were used. Details of the process are explained in the following sections along with the description of the site location and seismic hazard.

2.2 SITE HAZARD CHARACTERIZATION

The TBI building site is located in longitude = -118.25; latitude = 34.05; on site class C ($V_{S30} = 360$ m/sec). The site is 1.5 km from Puente Hills fault, 7.3 km from Hollywood fault, 8.8 km from Raymond fault, 11.5 km from Santa Monica fault, 24.5 km from Elsinore fault, 40 km from Sierra Madre fault system, and 56 km from San Andres fault. Figure 2.1 shows the location of the building in contrast with fault locations. It is clear that the building hazard can be dominated by near-field motions as well as far-field motions from extreme events.

To identify the dominant seismic events in different hazard levels, probabilistic seismic hazard disaggregation was used. Figures 2.2–2.6 show the disaggregation of hazard for the 2% in 50-years hazard level (2475-year return period) in the location of TBI building for periods

between 1.0 sec. to 5.0 sec. Similar figures for lower probability hazard levels were generated but not shown here. From this disaggregation of hazard, it became obvious that in rare events and for long periods the hazard is dominated by two types of events: a relatively large magnitude-small distance event (for example, $M = 6.6$, $R = 5$ km, $\varepsilon = 1.5$), or an extremely large magnitude-long distance event (for example, $M = 8$, $R = 60$ km, and $\varepsilon = 2.5$). For shorter periods in rare events, the hazard is dominated by the large magnitude-small distance events. At higher probability hazard levels, the dominance of a single or couple of events is reduced. These findings were used in selecting and scaling ground motions.

2.3 RECORD SELECTION PROCEDURE

2.3.1 Record Selection and Modification for Design Purposes

For design purposes, ground motions were selected whose spectra were matched to the design target spectrum (that is, a 43-year return period with 2.5% critical damping) for the location of the TBI building. In total, seven sets of two horizontal component records were developed. The seed records were selected according to disaggregation of the hazard at spectral periods of 1.0 sec and longer (see Table 2.1). The seed records were modified (in both the frequency and time domain) to closely match the target design spectrum over the spectral period range of 0.01 sec to 15.0 sec. The final modified acceleration, velocity, and displacement history for the first component of the first set is shown in Figure 2.7. The linear average of the 14 modified acceleration response spectra compared to the design target spectrum is shown in Figure 2.8.

2.3.2 Record Selection and Modification for Assessment Purposes

The performance assessment phase of the TBI structures was intended to estimate and compare the economical losses of various building designs. For that purpose, five hazard levels were selected that ranged from low probability (high intensity from extreme events) ground motions to high probability (low intensity from frequent events) ground motions. These hazard levels included return periods of 4975, 2475, 475, 43, and 25 years, denoted as OVE, MCE, DBE, SLE43, and SLE25, respectively. The target uniform hazard spectra for the location of the TBI building and 5% critically damped single-degree-of-freedom system (that is, the total of the five target uniform hazard spectra) were provided to the TBI research group by URS, Inc.

For each hazard level, 15 pairs of ground motions were selected and amplitude scaled to approximate the target spectra for that hazard level. Ground motions were selected from the subset of the Next Generation Attenuation (NGA) database of recorded ground motions that do not include records of aftershocks and foreshocks (for a total of 1561 pairs of ground motions). The process of selecting and scaling of ground motions for a target spectrum is as follows:

1. Subsets of recordings from the database of earthquake recordings were selected whose maximum source distance was 100 km, and the maximum shear wave velocity was between 180 to 1200 m/sec. These limits were considered to ensure that only those ground motions that represented the seismicity of the location of the TBI building were considered. Low-pass filter cutoff frequencies of the selected motions were less than 0.1 Hz to assure they included long-period excitation required for tall building performance assessment.
4. Response spectra for each component of a single recording were estimated for a 5% critically damped SDOF system. The geometric mean of two spectra was computed and considered as the spectrum associated with the single recording.
5. The scale factor, determined as the smallest error between the target spectrum and the geometric mean spectrum of a single recording, was computed. The maximum acceptable scale factor was considered to be equal to 5.0. To estimate the error, the spectral ordinates between periods of 0.5 sec to 10.0 sec (intervals of 0.1 sec) were considered; the errors were weighted to assure a better match in longer periods. Errors between periods of 0.5 and 3.0 sec were weighted 10%, errors between periods of 3.0 and 7.0 were weighted 60%, and errors between periods of 7.0 and 10.0 sec were weighted 30%.
6. The scaled recordings were sorted according to their total error, and the first 15 motions with smallest errors were selected without taking more than two recordings from any single event.
7. For the OVE hazard level only, which represented the rarest hazard level (that is, the 4975-year return period), seven pairs of ground motions were selected from the

database of recorded motions, and eight pairs were provided to the team by URS, Inc., from their database of simulated ground motions.

8. To reduce the analysis time, the selected ground motions were down sampled from their original sampling rate to a sampling rate of 25 samples per sec. Studies demonstrated that important response parameters are not significantly affected by this down sampling.

Figures 2.9-2.13 show the target response spectra for the five hazard levels: 4975-, 2475-, 475-, 43-, and 25-year return periods denoted as OVE, MCE, DBE, SLE43, and SLE25, respectively. This figures show a close match between the target spectra and median spectra in medium- and long-period range.

Table 2.1 Seed ground motions used in the spectral matching procedure to match ground motions the design target response spectrum.

Set Number	Earthquake	M_w	Station	R (km)
1	Denali	7.90	Pump Station #9	54.78
2	Loma Prieta	6.93	Saratoga	8.50
3	Northridge	6.69	Sylmar Converter Station	5.35
4	Denali	7.90	Carlo	50.94
5	Chi-Chi	7.62	CHY109	50.53
6	Denali	7.90	Pump Station #8	104.9
7	Landers	7.28	Yermo	23.62

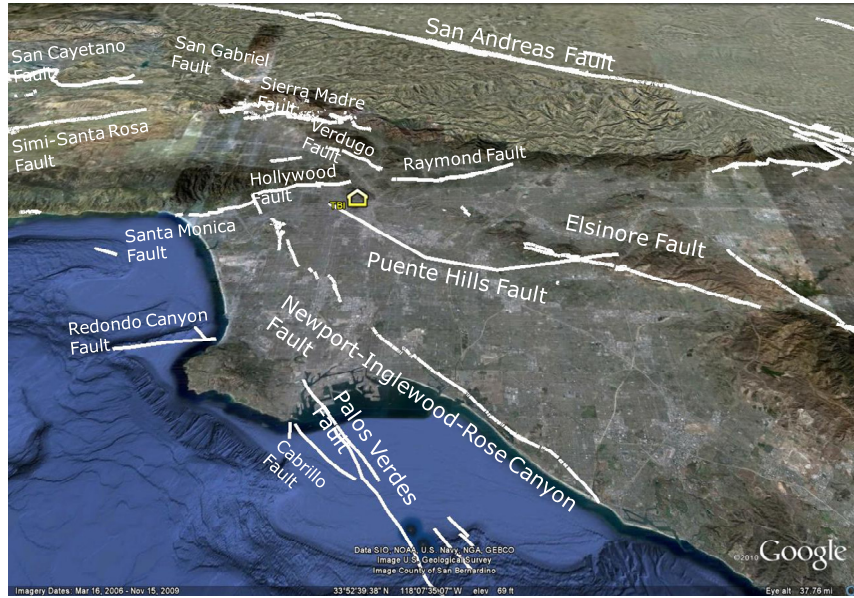

Figure 2.1 Location of TBI building in Southern California.

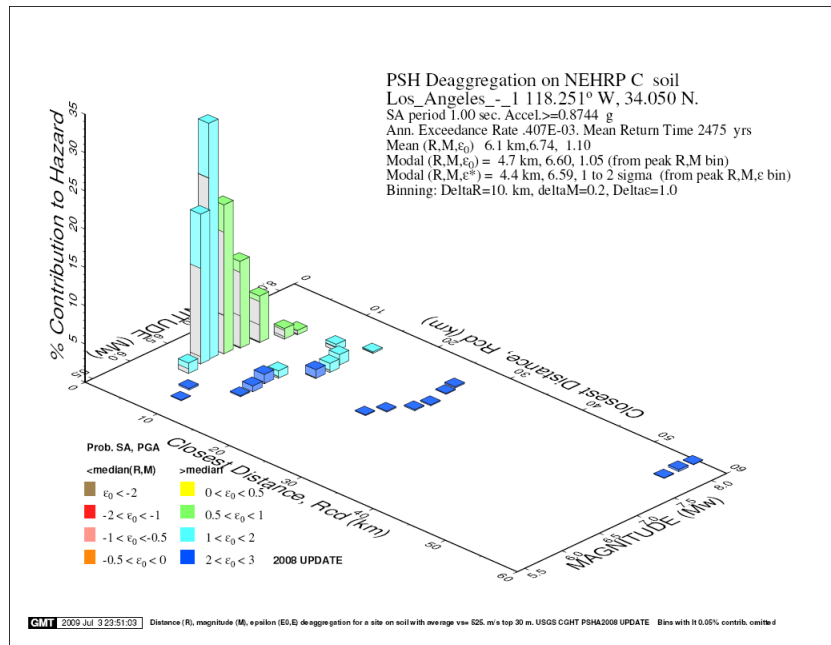

Figure 2.2 PSHA disaggregation for TBI buildings with 2475-year return period at 1.0 sec.

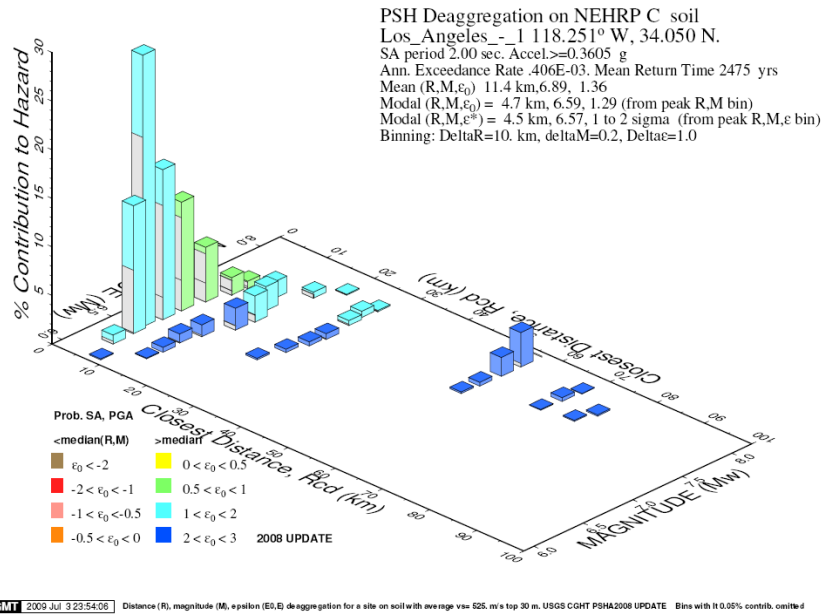

Figure 2.3 PSHA disaggregation for TBI buildings with a 2475-year return period at 2.0 sec.

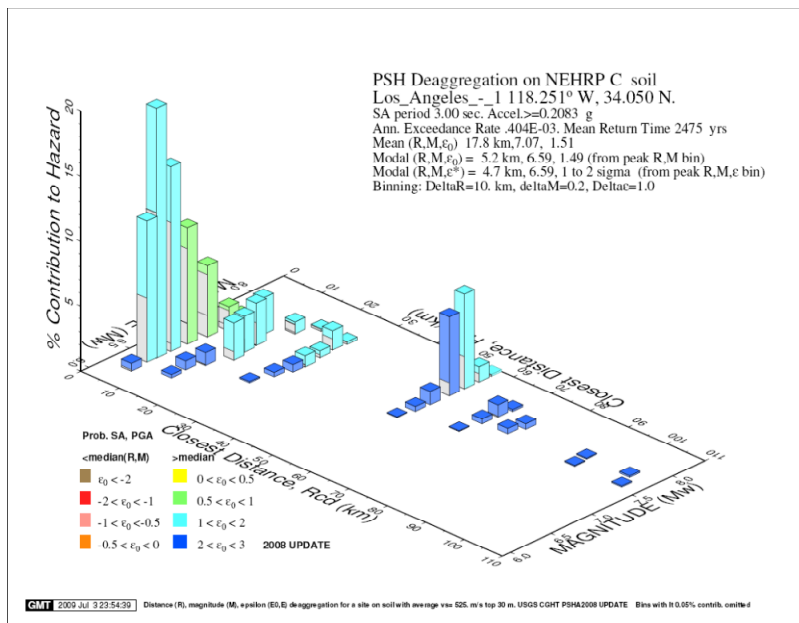

Figure 2.4 PSHA disaggregation for TBI buildings with a 2475-year return period at 3.0 sec.

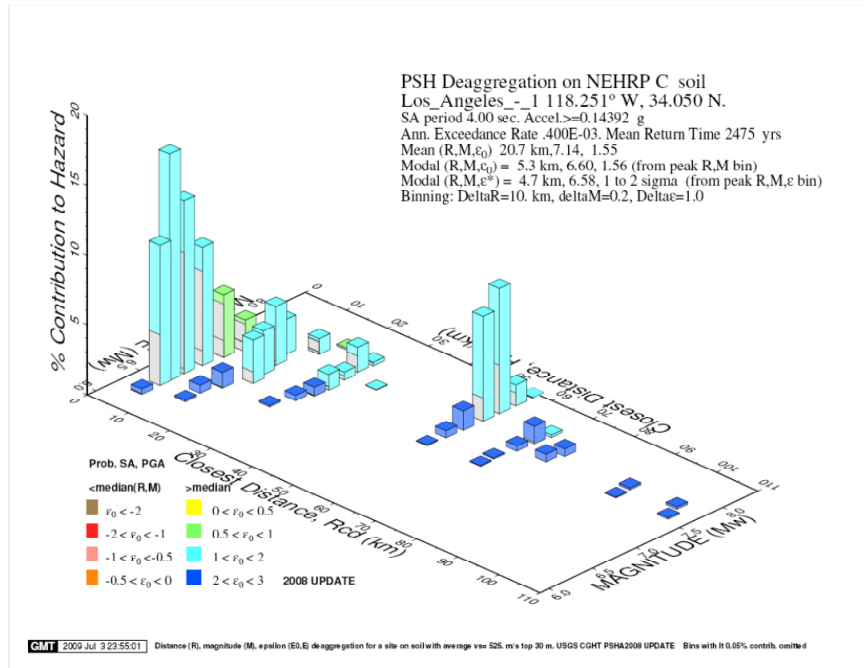

Figure 2.5 PSHA disaggregation for TBI buildings with a 2475-year return period at 4.0 sec.

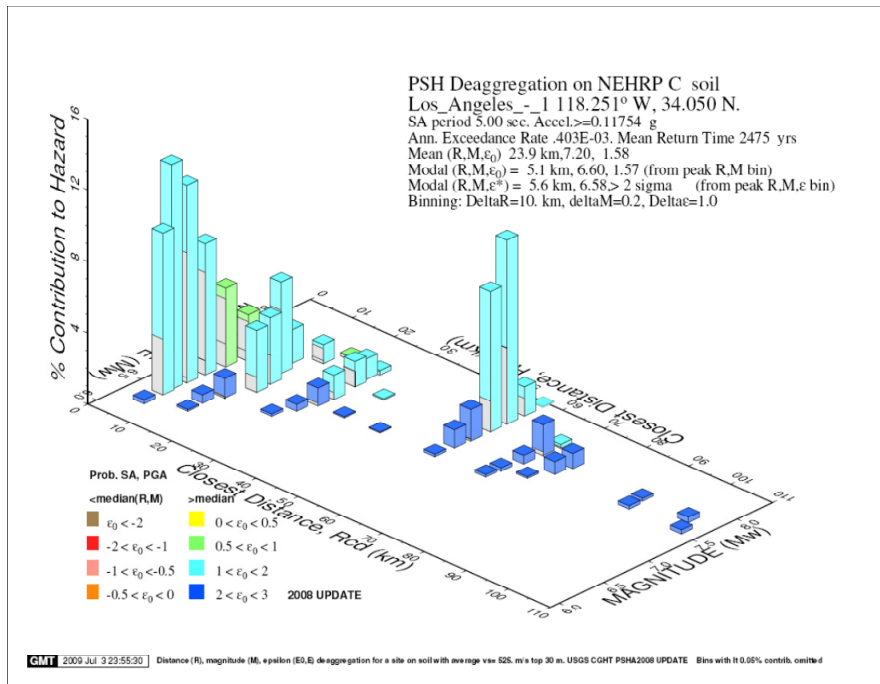

Figure 2.6 PSHA disaggregation for TBI buildings with a 2475-year return period at 5.0 sec.

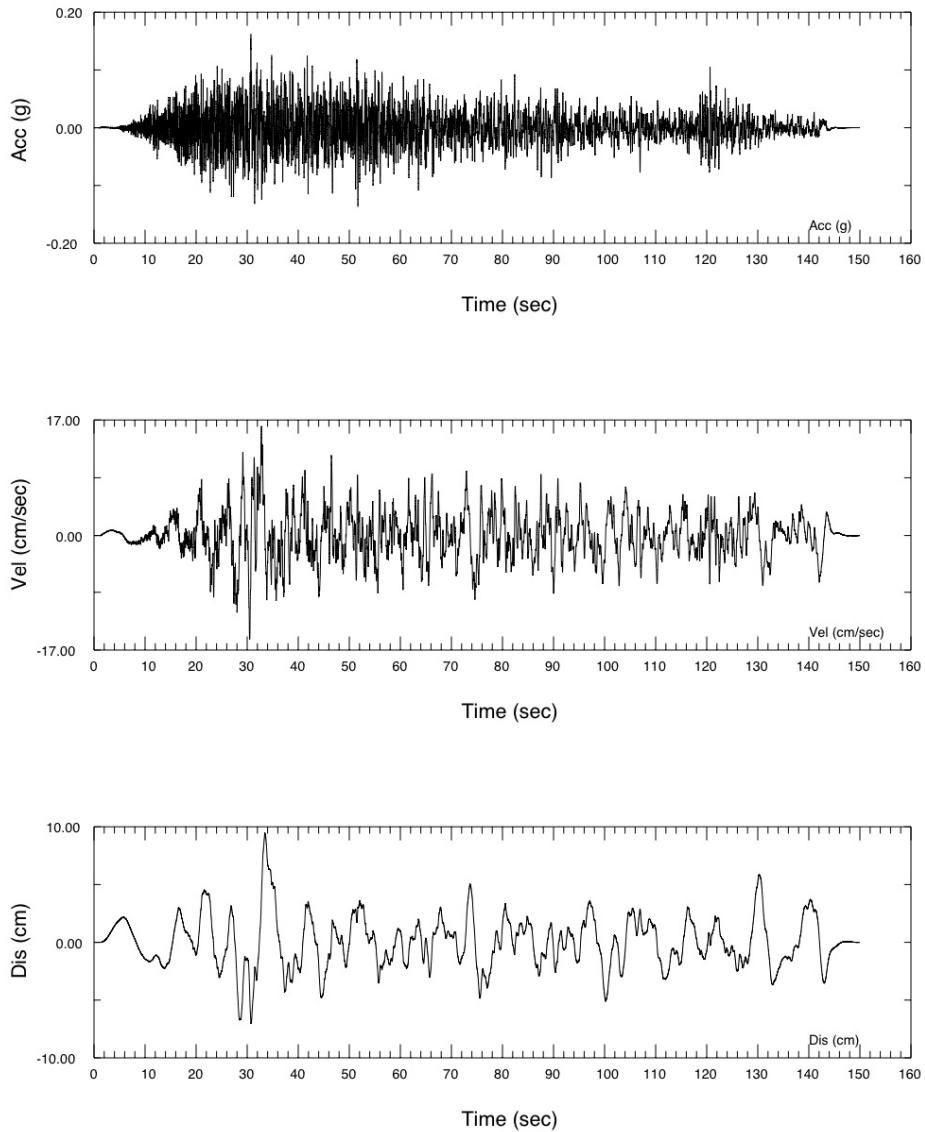

Figure 2.7 Spectrum compatible acceleration, velocity, and displacement histories for Set 1 (horizontal 1 component) matched to the design target response spectrum.



Figure 2.8 Comparison between the average modified spectrum compatible acceleration histories response spectrum for all 14 spectrum compatible histories and the target design response spectrum.

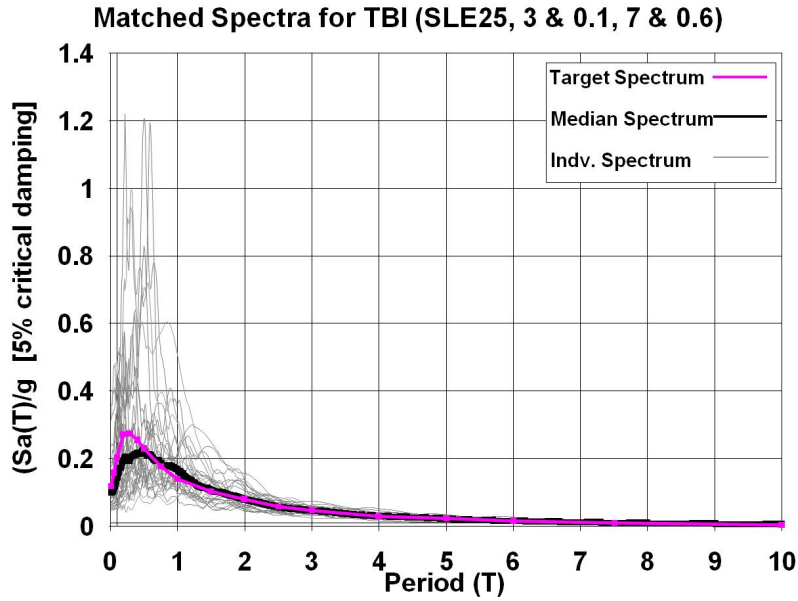

Figure 2.9 Comparison between the target spectrum, selected and scaled ground motion spectra, and median spectrum of selected and scaled ground motions for the SLE25 hazard level.

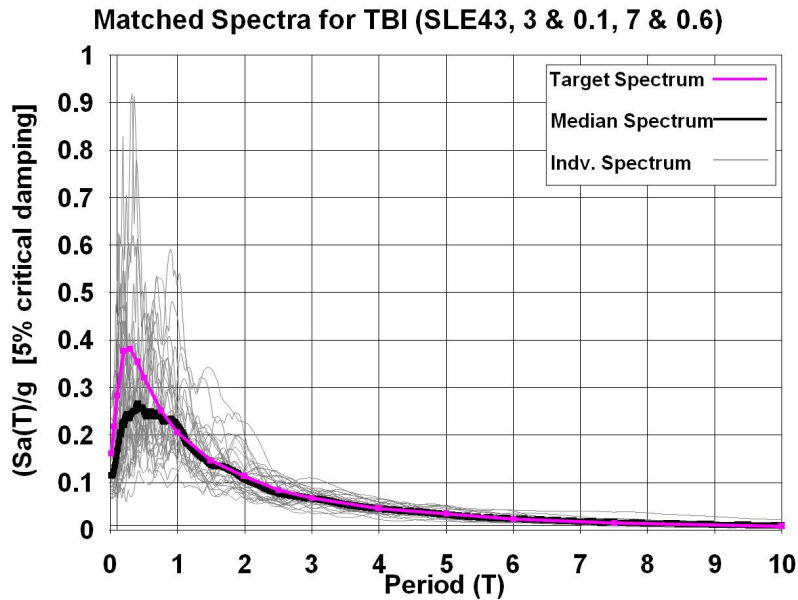

Figure 2.10 Comparison between the target spectrum, selected and scaled ground motion spectra, and median spectrum of selected and scaled ground motions for the SLE43 hazard level.

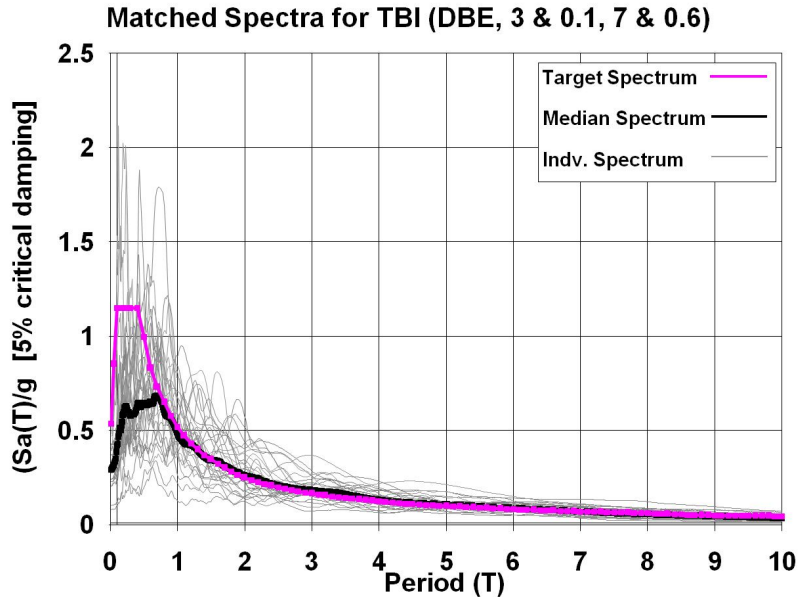

Figure 2.11 Comparison between the target spectrum, selected and scaled ground motion spectra, and median spectrum of selected and scaled ground motions for the DBE hazard level.

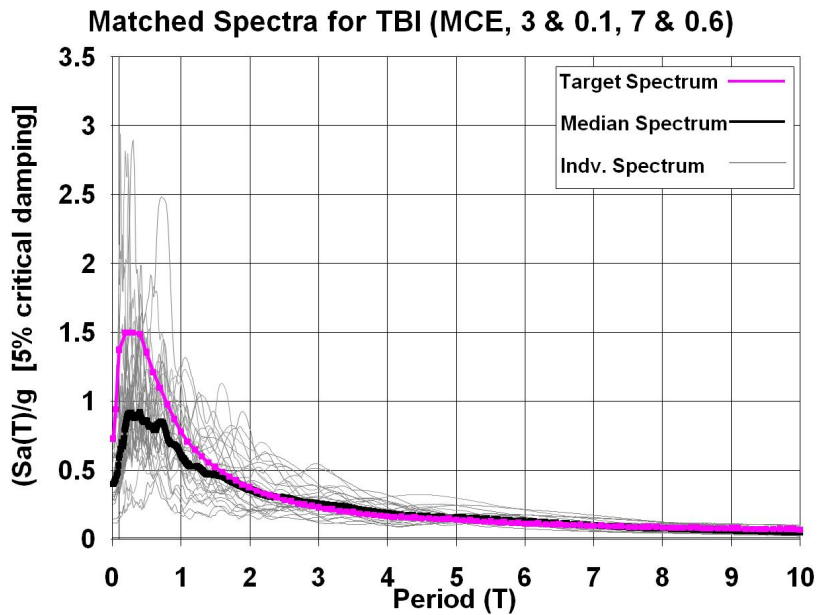

Figure 2.12 Comparison between the target spectrum, selected and scaled ground motion spectra, and median spectrum of selected and scaled ground motions for the MCE hazard level.

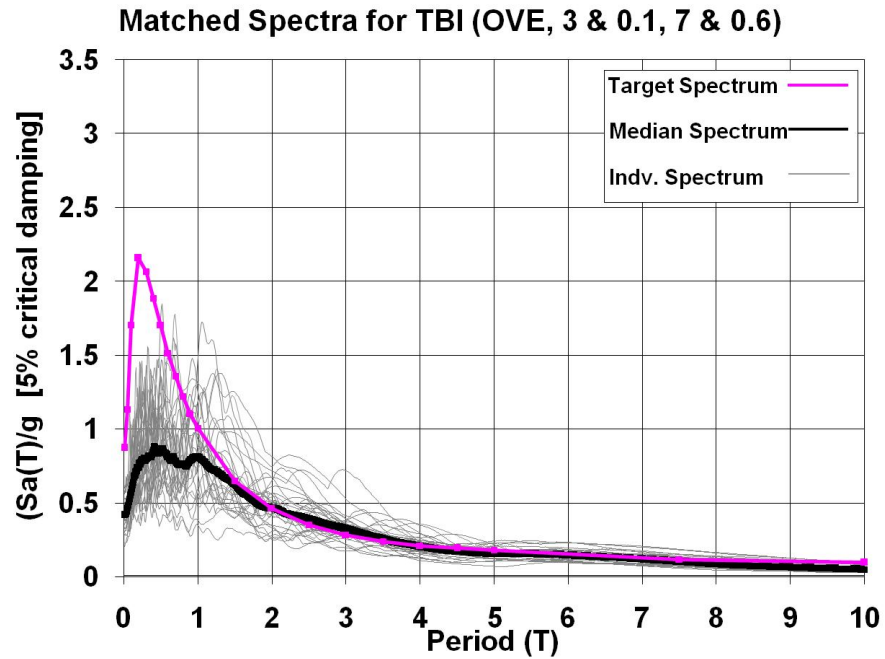

Figure 2.13 Comparison between the target spectrum, selected and scaled ground motion spectra, and median spectrum of selected and scaled ground motions for the OVE hazard level.

3 Design and Performance of Building 1: Core Wall Only Structural System

3.1 INTRODUCTION

Building 1 is a 42-story residential building located in Los Angeles, California. The building consists of a centrally located core wall with coupling beams surrounded by concrete perimeter columns. Figure 3.1 shows an isotropic view of the prototype model. Figure 3.2 shows a typical floor plan of the prototype model.

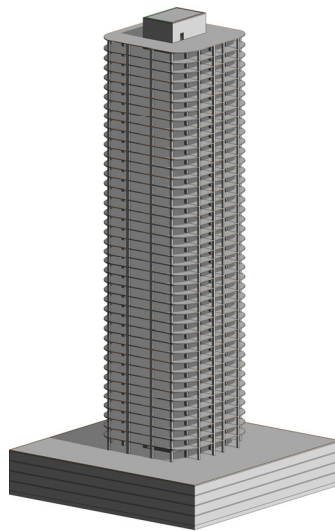

Figure 3.1 Isotropic view of the prototype building.

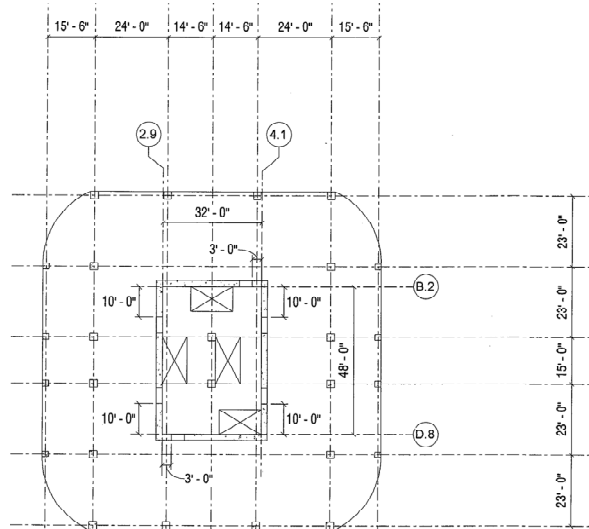

Figure 3.2 Plan view of the prototype building.

3.2 DESIGN OF BUILDING 1 STRUCTURAL SYSTEM

The prototype building was designed according to three provisions (details are provided in Appendix A of this report):

- 1A - Code: Prescriptive provisions as outlined in the 2006 International Building Code (IBC). All prescriptive provisions of the building code were observed except the height limit.
- 1B – LATBC: A performance-based design as outlined in the 2008 seismic design criteria published by the Los Angeles Tall Buildings Structural Design Council (LATBSDC). All prescriptive provisions of the LATBSDC document were observed with the following exceptions (based on consensus of the TBI team to contrast with Case 1C, below): (1) the minimum base shear specified by LATBSDC document was not followed; and (2) a serviceability analysis was checked using an earthquake with 25-year return period and 2.5% viscous damping. Only 20% of elements were allowed to reach 150% of their capacity. The minimum base shear requirement was dropped based on consideration of the procedures required in these Guidelines. Specifically, these *Guidelines* require use of nonlinear dynamic analysis at the MCE level, with relatively conservative procedures for analysis and acceptance. Results of the MCE evaluation should indicate whether the provided strength produces acceptable response under MCE shaking levels. The prescriptive minimum base shear

requirement of the current building codes could be applied as an additional requirement, but this was deemed not necessary by the project team. Rather, the prescriptive minimum base shear requirement is more appropriate for design of buildings by linear analysis methods, as those methods do not provide a direct evaluation of nonlinear performance under MCE shaking and a previous study indicates the minimum base shear strength is necessary as a collapse-prevention safeguard for MCE shaking [Haselton et al 2011].

- 1C – PEER TBI: A performance-based plus design outlined by the PEER TBI team. The building was designed with higher performance objectives, including a serviceability analysis using a 43-year return period earthquake with 2.5% viscous damping. For the serviceability analysis, ductile elements (coupling beams for core wall building) were allowed to reach 150% of their capacity, and the wall piers were limited with an axial stress $< 0.3 f'_c$. The minimum strength was calculated based on the maximum of the 43-year return earthquake and wind loads.

Table 3.1 shows a summary of the structural element sizes; Table 3.2 shows the structural material properties; Figure 3.3 shows the comparison of the steel reinforcement in the coupling beams from the three designs; and Figure 3.4 shows the comparison of the vertical steel reinforcement in the concrete core wall.

Table 3.1 Element sizes.

Element	Structural System and Sizes
Foundation	A mat foundation of variable thickness under the tower footprint
Core Walls	Core walls of variable thickness
Columns	Reinforced concrete columns ranging from 18"x18" to 36"x36"
Basement Walls	16-inch thick reinforced concrete basement walls around the perimeter of the below-grade parking levels
Below-Grade Slabs	10-inch-thick reinforced concrete flat slabs
Grade-Level Slab	12-inch-thick reinforced concrete flat slab
Residential Slabs	8-inch-thick post-tensioned concrete flat slabs
Roof Slab	10-inch-thick reinforced concrete slab

Table 3.2 Structural material properties.

Member	Nominal f'_c	Expected f'_c	Nominal E	Expected E
Basement Walls	5.0 ksi	6.5 ksi	3,830 ksi	4,225 ksi
Foundation Mats	6.0 ksi	7.8 ksi	4,100 ksi	4,530 ksi
Non-Post-Tensioned Beams and Slabs	5.5 ksi	7.2 ksi	3,970 ksi	4,395 ksi
Post-Tensioned Floor Slabs	5.5 ksi	7.2 ksi	3,970 ksi	4,395 ksi
Columns	8.0 ksi	10.4 ksi	4,580 ksi	5,080 ksi
Shear Walls	8.0 ksi	10.4 ksi	4,580 ksi	5,080 ksi
Standard	Nominal f_y	Expected f_y	Expected f_u	
ASTM A615 Grade 60	60 ksi (non-seismic)	N/A	N/A	
ASTM A706 Grade 60	60 ksi (seismic)	70 ksi	105 ksi	
ASTM A615 Grade 75	75 ksi (used in coupling beams)	85 ksi	130 ksi	
Standard	Nominal f_u	Expected f_u		
0.5-inch-diameter, 7-wire strand	$f_{pu} = 270$ ksi	N/A		

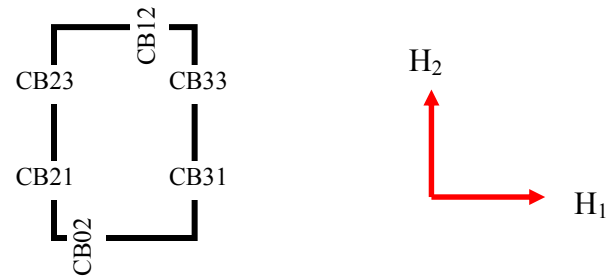
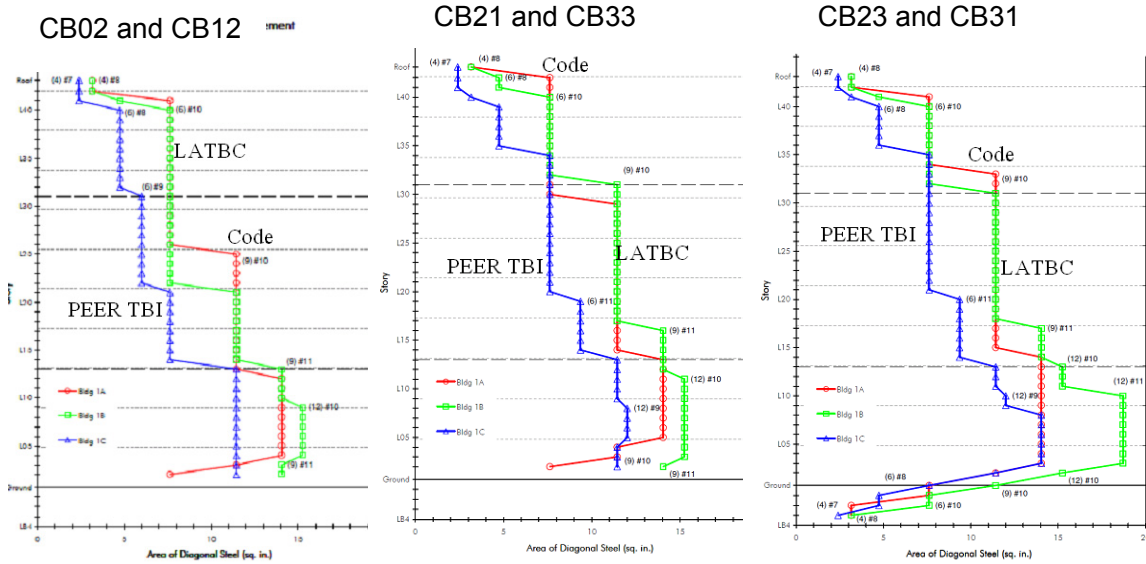

Figure 3.3 Steel reinforcement in the coupling beams.

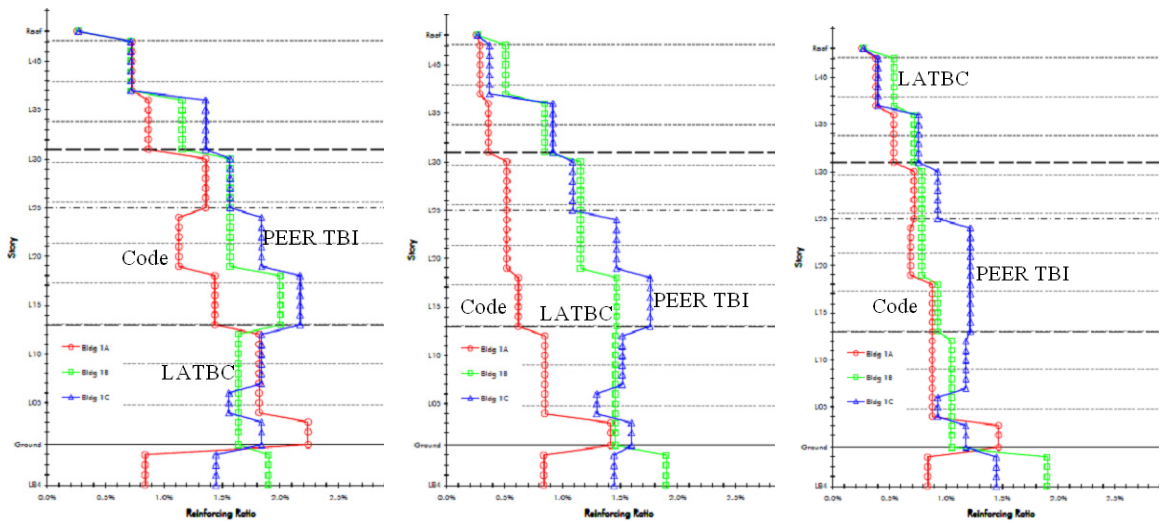

Figure 3.4 Vertical steel reinforcement in the concrete core wall.

3.3 DEVELOPMENT OF THE STRUCTURAL ANALYSIS MODELS FOR BUILDING 1

The analytical models were developed using Perform-3D [CSI 2009]. Figure 3.5 shows the isometric view of the analytical model.

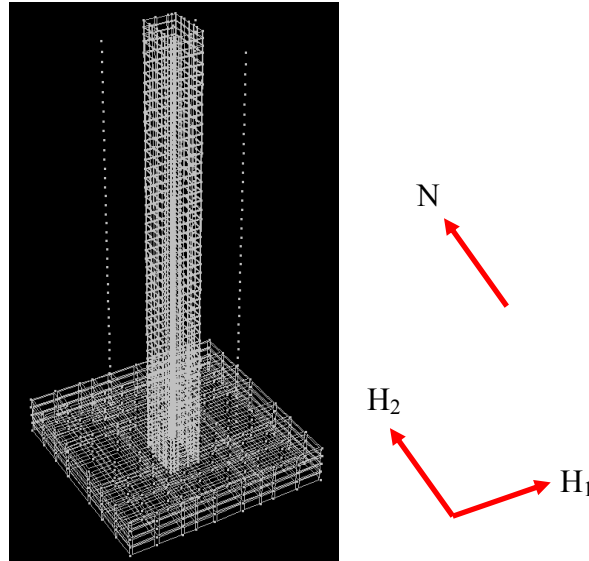

Figure 3.5 Isotropic view of the analytical model.

Gravity columns and slabs were not modeled in the analytical model. (Studies with and without the slab-column framing have shown that ignoring the slab-column framing does not affect the response to any degree.) The nodes at each floor were tied using a rigid diaphragm constraint. The boundary conditions were modeled using pin connections at the base of the building. The axial and bending interaction of the concrete shear wall were modeled using the inelastic fiber shear wall element in Perform3-D. The in-plane shear strength of the concrete shear wall was modeled using an inelastic shear spring in Perform-3D, where the ultimate strength was limited to $1.5V_n$ (calculated using ACI-318). The coupling beams were modeled using two elastic beam-column elements with a nonlinear displacement-based shear hinge in the middle. Detailed modeling parameters and assumptions are summarized in Naish et al. [2009]. The basement perimeter shear walls were modeled using elastic shear wall elements in Perform-3D, with a reduction factor of 0.8 to account for the cracking of concrete material. The slabs at the basement levels were modeled using the elastic shell element in Perform-3D, with a reduction factor of 0.25 to account for the cracking of concrete material. Appropriate gravity

load were applied as point loads on a P-Δ column (an axially rigid but flexural flexible elastic column located at the center of the building) and as distributed line load on the concrete core shear wall. Floor masses were assigned as lumped floor masses on the floors above grade. Figure 3.6 shows the comparison of the first two modes for the three models:

Model 1A	Model 1A	Model 1B	Model 1B	Model 1C	Model 1C
					
T1 = 5.2 sec	T2 = 4.0 sec	T1 = 4.8 sec	T2 = 3.6 sec	T1 = 4.6 sec	T2 = 3.5 sec
$M_{H1} = 0.61$	$M_{H1} = 0$	$M_{H1} = 0.6$	$M_{H1} = 0$	$M_{H1} = 0.58$	$M_{H1} = 0$
$M_{H2} = 0$	$M_{H2} = 0.63$	$M_{H2} = 0$	$M_{H2} = 0.61$	$M_{H2} = 0$	$M_{H2} = 0.61$
$M_V = 0$	$M_V = 0$	$M_V = 0$	$M_V = 0$	$M_V = 0$	$M_V = 0$

Figure 3.6 Comparison of the modal period.

3.4 BUILDING 1 ANALYSIS RESULTS AND DISCUSSION

A series of response history analyses (RHAs) were conducted using the ground motions presented in the previous chapter. A 2.5% Rayleigh mass and stiffness proportional damping factors were assigned to the model at periods of 1 sec and 5 sec. Figures 3.7-3.11 show some sample structural response histories recorded from different hazard levels.

Figures 3.12 and 3.13 show maximum floor accelerations and interstory drift ratios for Building 1C at each hazard level, respectively. The dashed lines represent the maximum absolute response obtained from each of the analyses. The solid line represents the average of the maximum response. Mean story drift ratios (SDR) are somewhat lower for Design B. Mean peak floor accelerations (PFAs) are similar for both building designs.

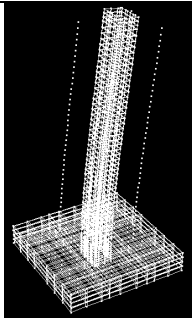
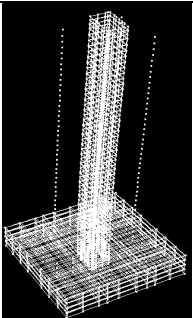
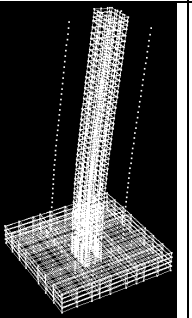
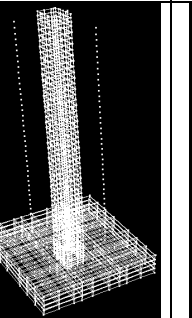
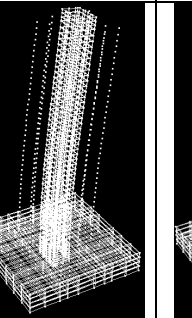
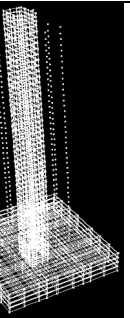
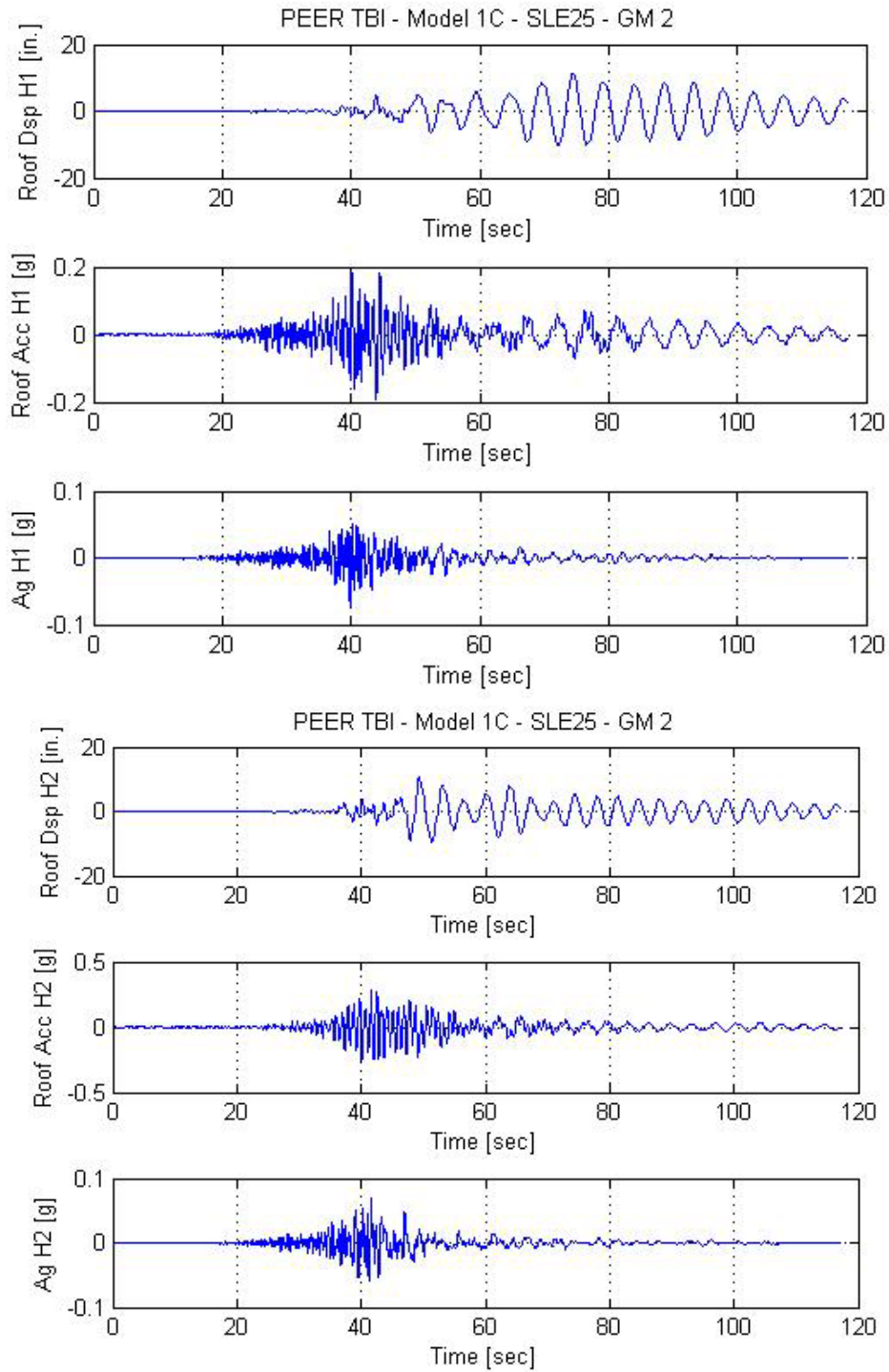

Figure 3.7 Sample response history at the SLE25 hazard level.

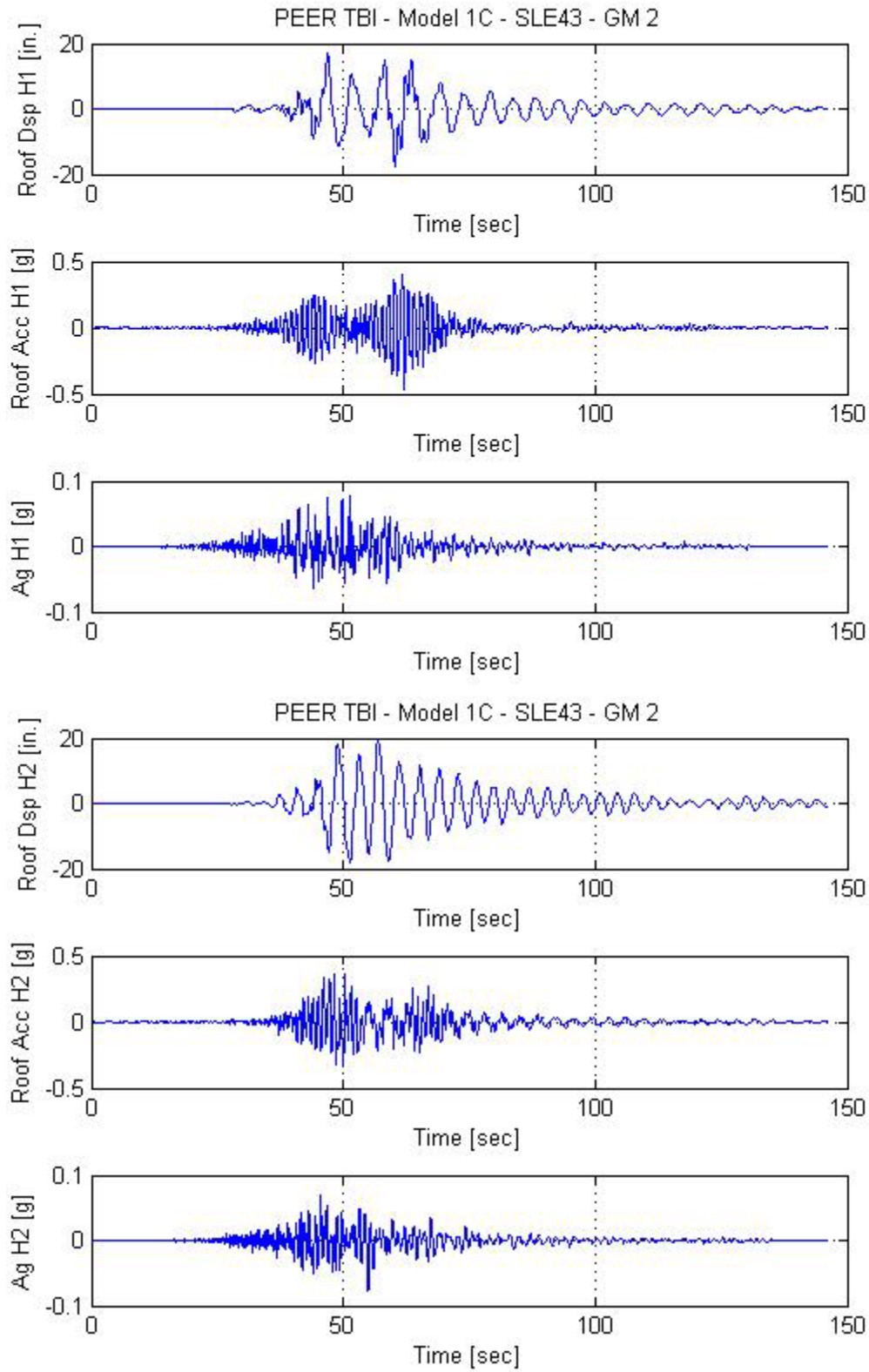

Figure 3.8 Sample response history at the SLE43 hazard level.

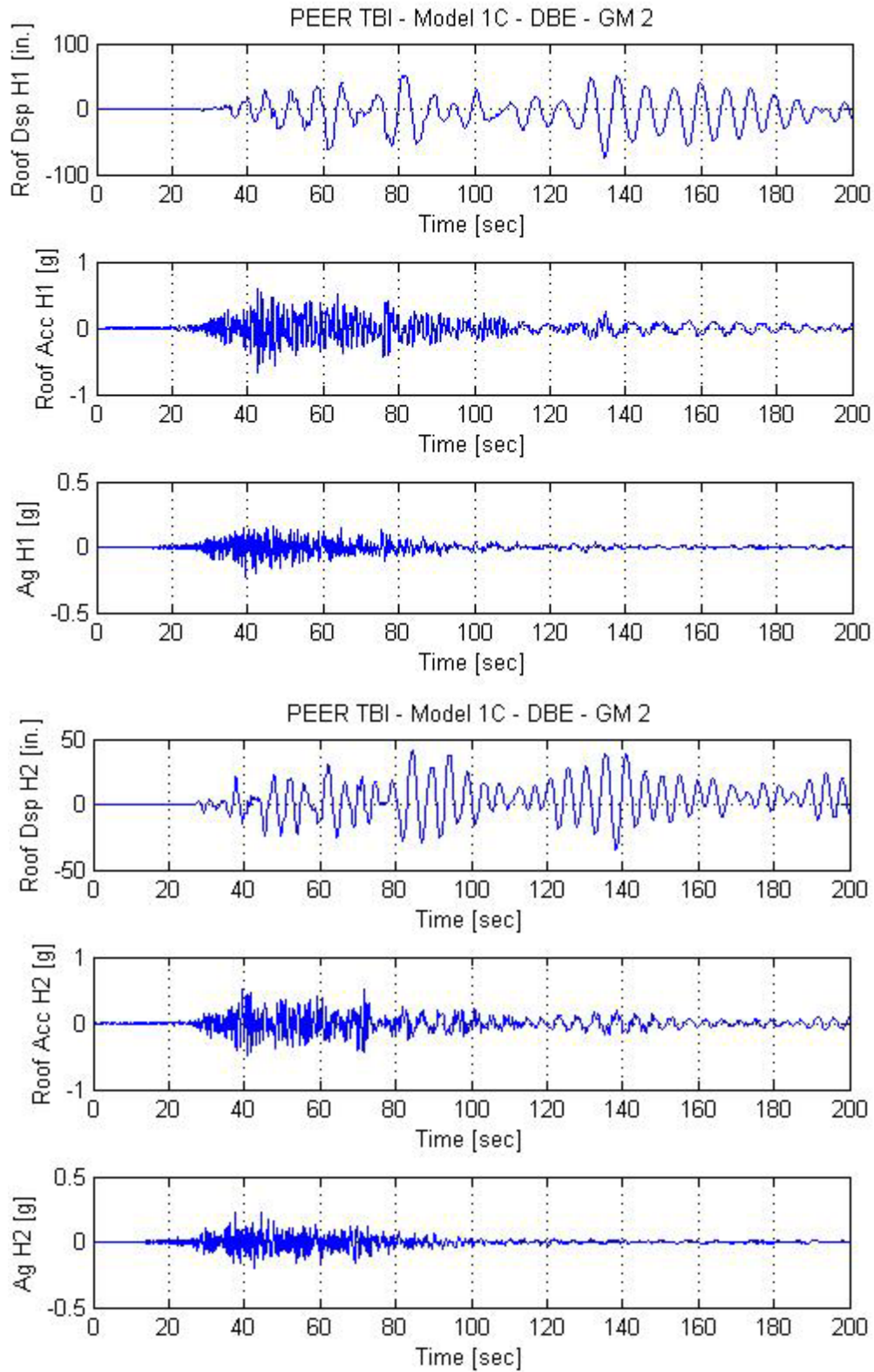

Figure 3.9 Sample response history at the DBE hazard level.

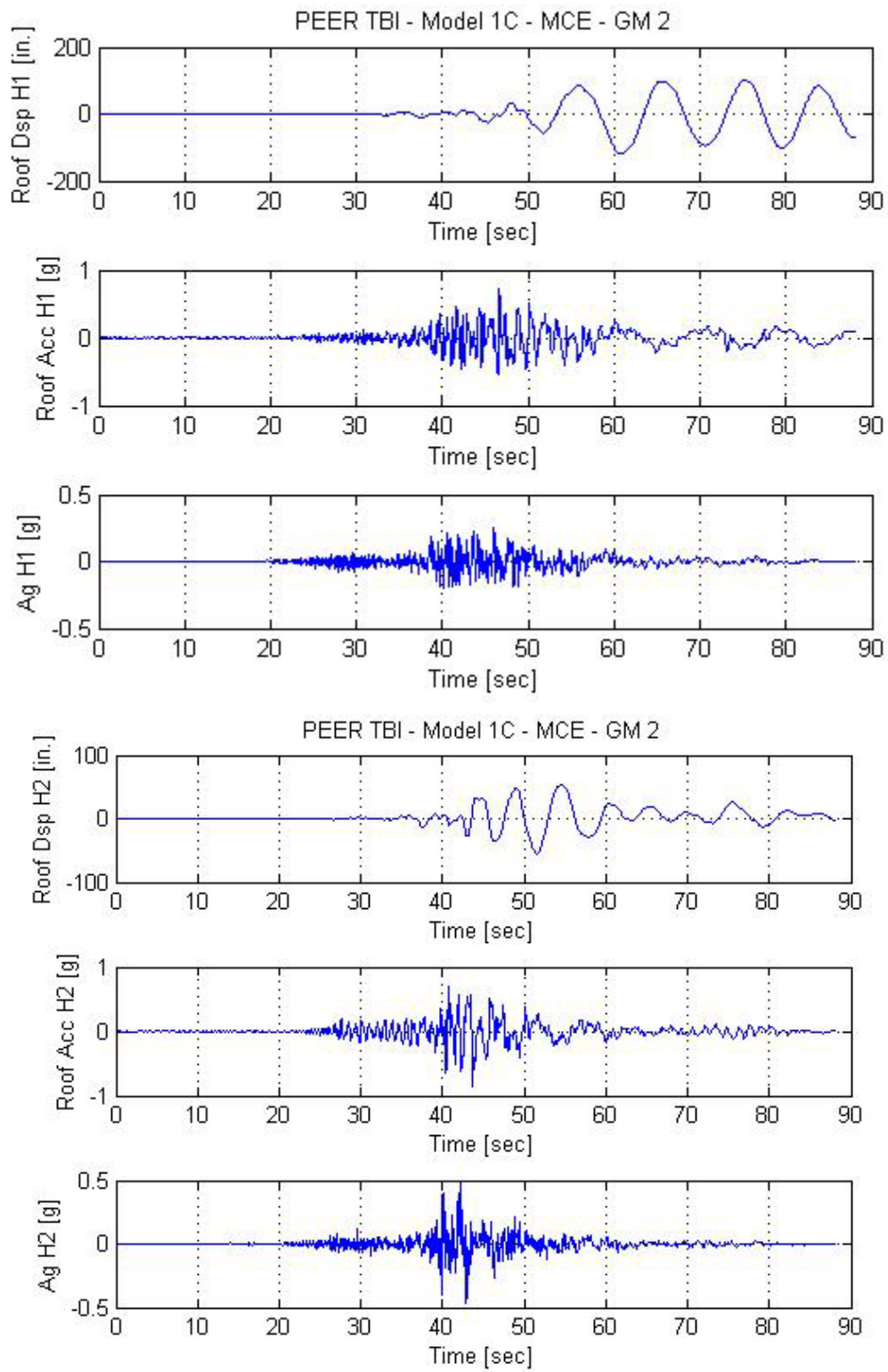

Figure 3.10 Sample response history at the MCE hazard level.

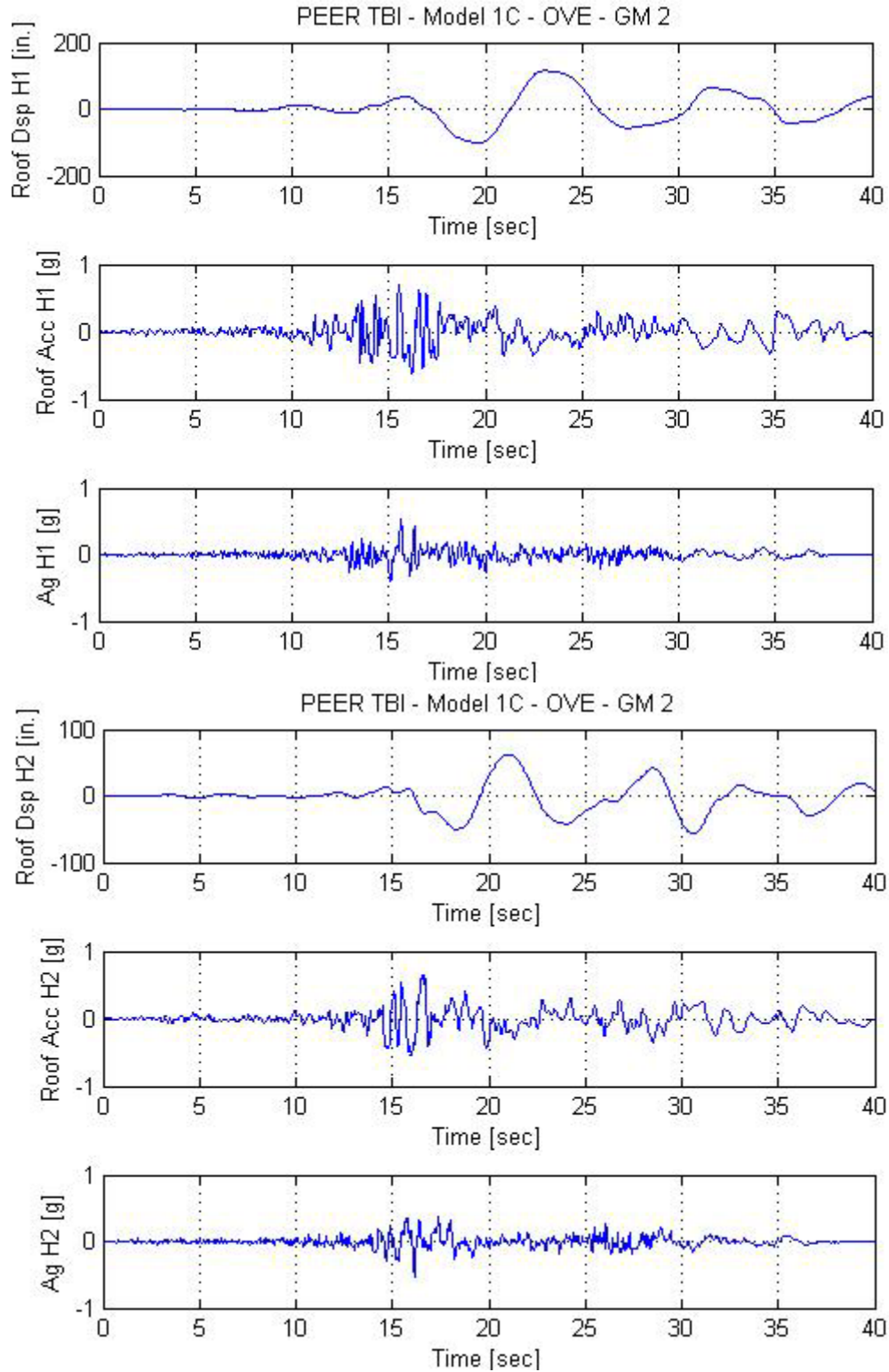

Figure 3.11 Sample response history at the OVE hazard level.

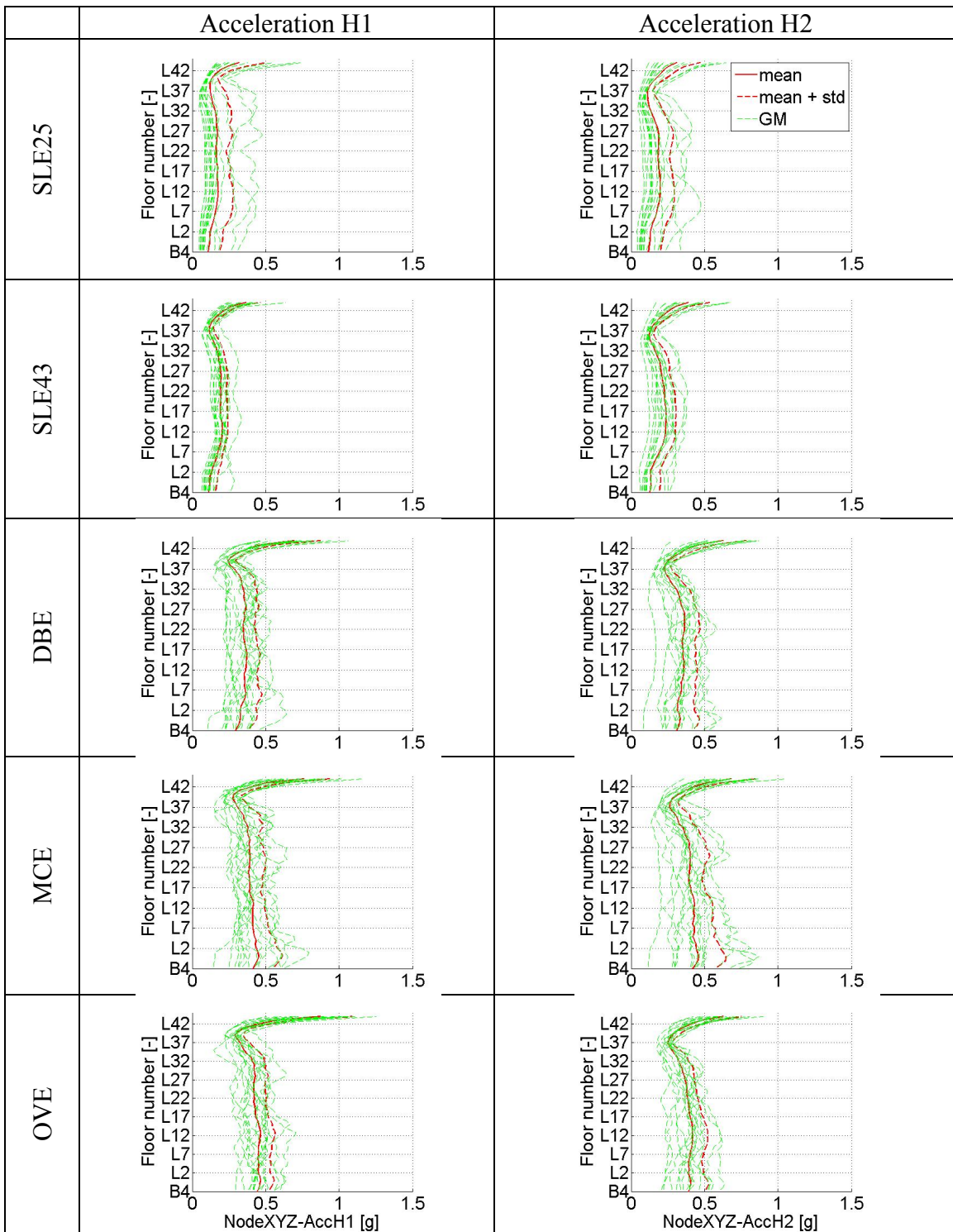

Figure 3.12 Peak floor accelerations.

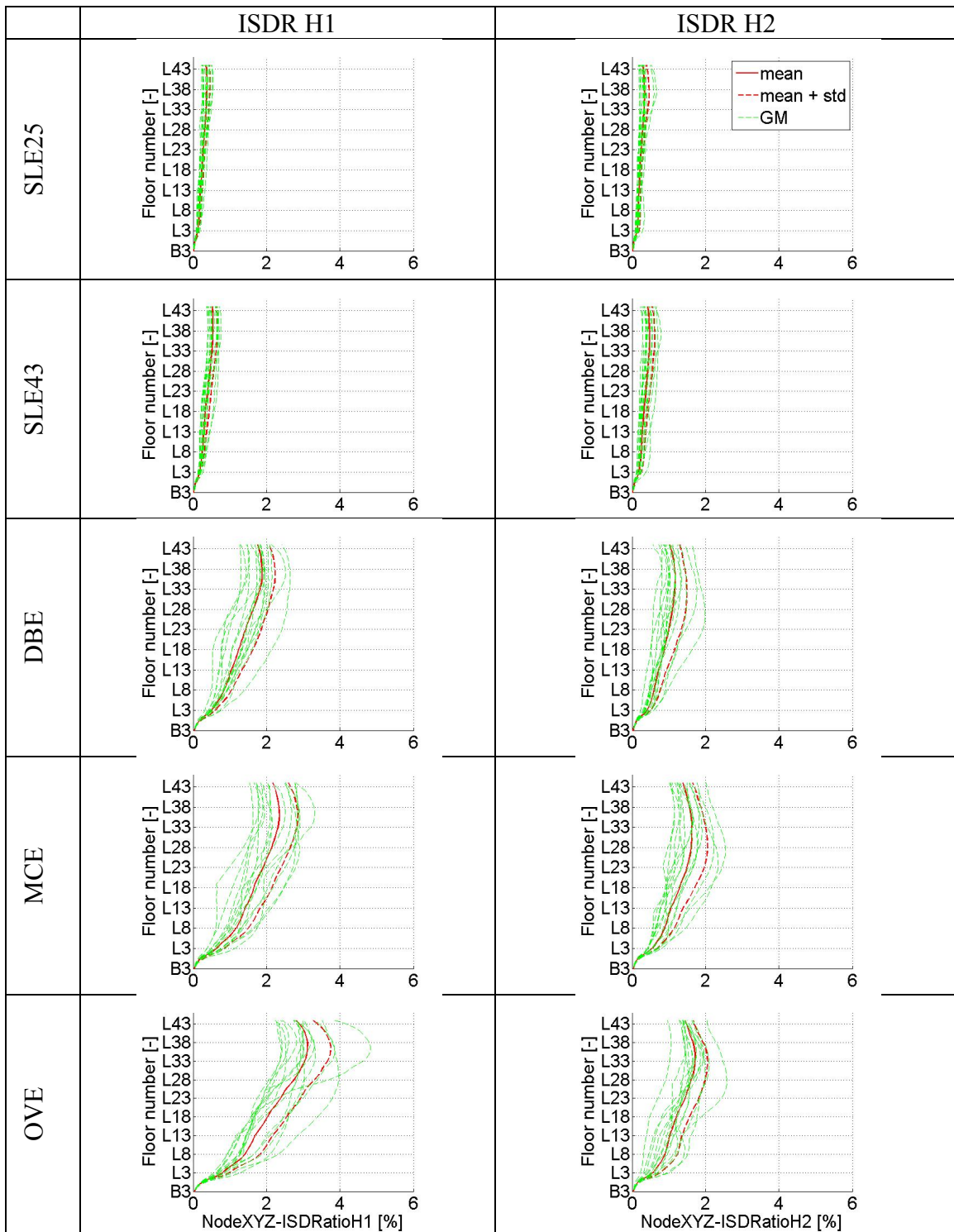

Figure 3.13 Peak interstory drift ratios.

4. Design and Performance of Building 2: Core Wall / Special Moment Frame Dual Structural System

4.1 INTRODUCTION

The dual system building was designed to have 42 stories above ground and four, 10.5 ft-high stories below ground, with and a 20-ft tall penthouse (see Figure 4.1) Details of the design are provided in Appendix B. The lateral-force-resisting system consists of a core wall and four-bay SMFs at the perimeter of the building on all four sides. The core walls are composed of L-shaped walls connected with coupling beams that are typically 30 in. deep. The core wall continues through to the basement levels to the foundation, and 16-in.-thick exterior basement walls exist around the perimeter of the 4-story podium below grade. A diaphragm exists at ground level to transfer loads to the perimeter basement walls.

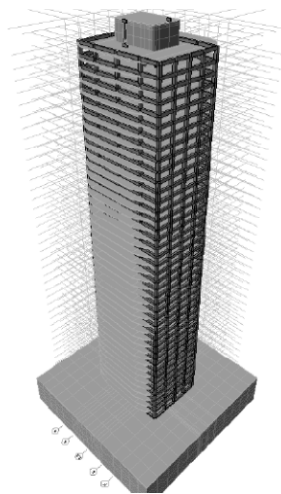

Figure 4.1 Three-dimensional building view.

4.2 DESIGN OF BUILDING 2 STRUCTURAL SYSTEM

Building 2A was designed according to building code provisions in IBC 2006, which requires using ASCE 7-05 and ACI 318-08. Although a height limit of 160 ft exists for core-wall only systems, the code does not specify a height limit for dual systems; therefore, the code is followed prescriptively. A modal response spectrum analysis was used for site-specific response spectra for 5% damping in accordance with ASCE 7-05 (Figure 4.2). A period summary is provided in Table 4.1.

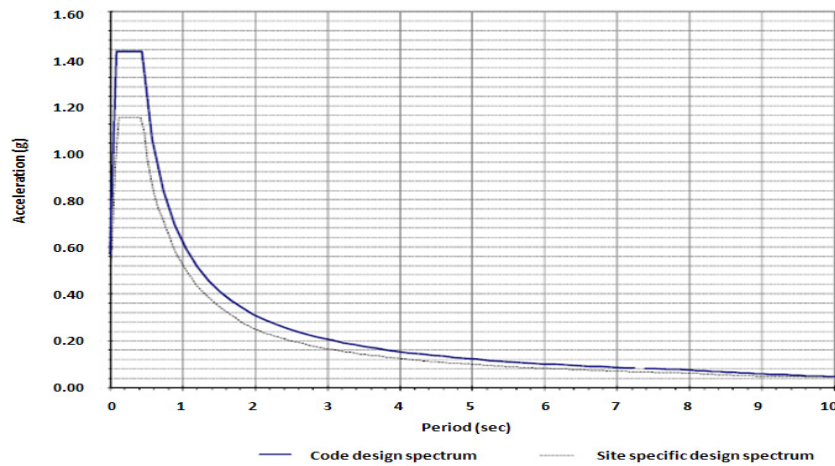

Figure 4.2 5% damped code and site-specific design response spectra.

Table 4.1 Period and mass participation summary.

Vibration Mode	Period (sec)	Mass Participation		Dominant Direction
		H1	H2	
1	4.456	70.70%	0.02%	Translation mode on H1 direction
2	4.026	0.01%	71.12%	Translation mode on H2 direction
3	2.478	0%	5.92 e-5%	Torsion mode

For the core wall, the specified concrete strength f'_c is taken as 6000 psi for the floors from the foundation to the twentieth floor with 24-in.-thick walls, and as 5000 psi above the twentieth floor with 18-in.-thick walls. The core wall consists of L-shaped sections connected by 30-in.-deep coupling beams over doorways that provide access to elevators and stairs. Coupling beam reinforcement details are presented in Figure 4.3 for each direction.

For the SMF design, all beams have cross-section dimensions of 30 in \times 36 in. with $f'_c = 5000$ psi. All North and South columns (frames A and F) are 36 in \times 36 in. with f'_c varying from 10,000 psi to 5000 psi along the height. The East and West columns (frames 2 and 5) vary both in size (from 46 in \times 46 in. to 36 in \times 36 in., with the f'_c ranging from 10,000 psi to 5000 psi along the height. Typical frame beam and column cross-sections are presented in Figure 4.4. All reinforcement consists of A706 Grade 60 reinforcing bar. The reinforcement details of frame members are available in Appendix B. The floor consists of a reinforced concrete slab, which is 10 in. thick at basement levels, 12 in. thick at the ground level, 8 in. thick in the tower, and 10 in. thick at the roof level. Slabs in the tower are post-tensioned. A 16-in.-thick basement wall exists below grade.

Building 2B, which has the same layout and floor plan as Building 2A, was designed and checked for Serviceability and Collapse Prevention level using 2008 LATBSDC, with the following exceptions noted:

- The service level check was for an earthquake event with a 25-year return period with 2.5% viscous damping. Up to 20% of the elements with ductile action were allowed to reach 150% of their capacity under the serviceability check.
- The minimum base shear specified in the LATBSDC (2008) was waived.
- Strengths for ductile actions at service level were calculated using strength reduction factors per ACI 318-08.

For the serviceability level, the design forces were obtained using an elastic site-specific response spectrum analysis where the spectrum represents a mean recurrence interval of 25 years, (Figure 4.4). Design acceptance criteria are summarized in Appendix B.

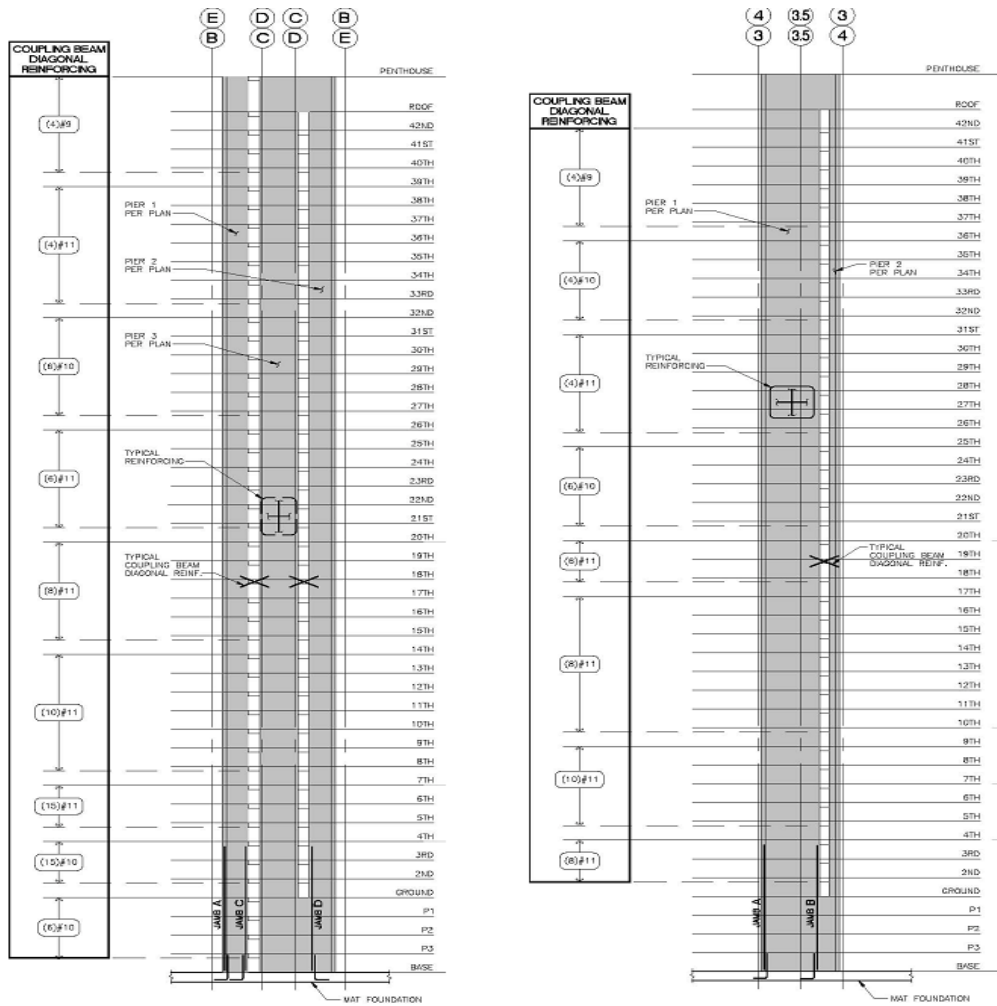

Figure 4.3 Coupling beam reinforcement details.

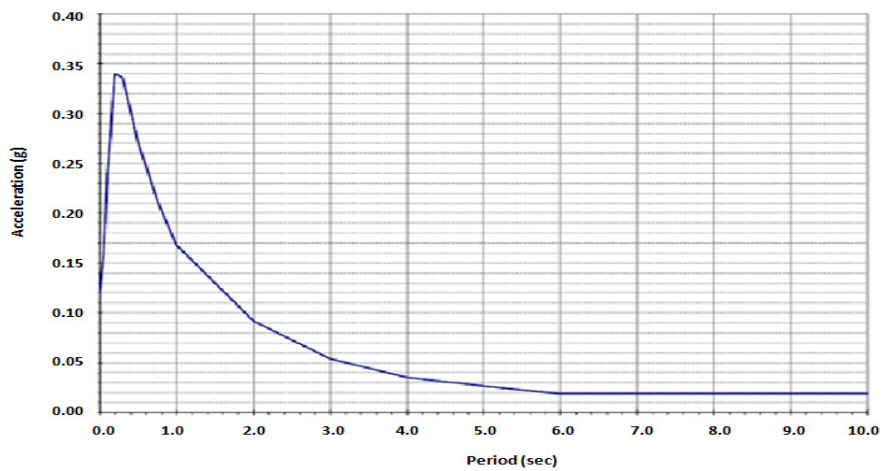

Figure 4.4 Serviceability level spectra.

Building 2B, which was initially designed for serviceability level forces, was revised to comply with MCE level forces. For this purpose, a nonlinear three-dimensional model was created in Perform-3D (see Section 4.3 for more details). The components were checked using a nonlinear response history analysis (RHA) based on the collapse prevention acceptance criteria detailed in Appendix B. In order to represent the MCE level, seven pairs of spectrum-matched ground motions with a mean return period of 2475 years were used. The design was based on the target acceleration response spectrum shown in Figure 4.5 and was selected to reasonably match the code spectrum. A summary of the periods for different vibration modes is provided in Table 4.2. Details of the design acceptance criteria can be found in Appendix B.

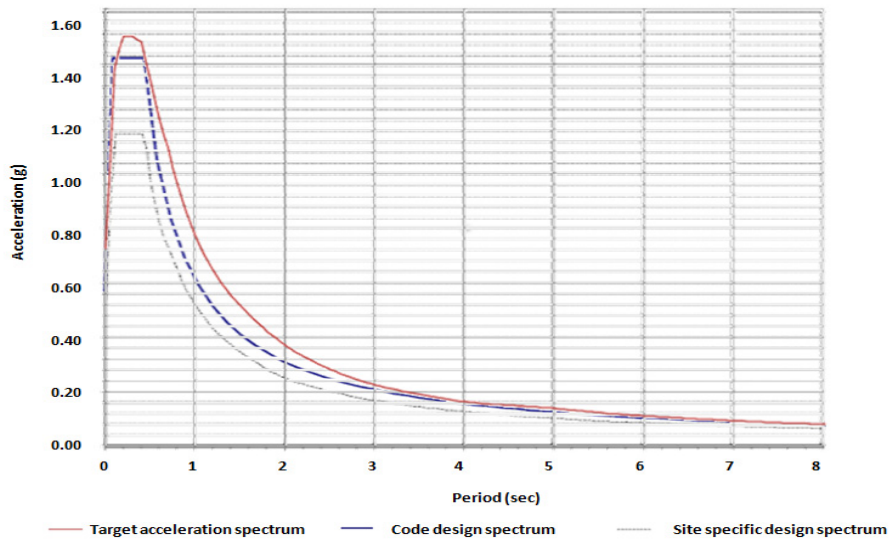

Figure 4.5 Target acceleration response spectra at the MCE level.

Table 4.2 Period and mass participation summary.

Vibration Mode	Period (sec)	Mass Participation		Dominant Direction
		H1	H2	
1	4.276	70.75%	0.02%	Translation mode on H1 direction
2	3.881	0.01%	70.94%	Translation mode on H2 direction
3	2.39	2 e-7 %	6 e-5 %	Torsion mode

Core walls were strengthened by introducing a specified concrete strength of $f'_c = 8000$ psi for the 24-in.-thick core walls from the foundation to the twentieth floor) and an $f'_c = 6000$ psi for the 18-in.-thick core walls (from twentieth to the thirtieth floor). Above the thirtieth floor, the wall thickness decreased to 16 in. but the concrete strength was kept the same.. The configuration of the coupling beams was kept the same, but the capacities were increased with a higher concrete strength. Frame members retained the same cross-section dimensions except for the North and South corner columns (frames A and F), which were increased to 46 in \times 46 in from the foundation to tenth floor) and to 42 in \times 42 in from tenth to thirtieth floor). The amount of reinforcement amount in the frame beams and corner columns was decreased, but increased in East and West interior columns (frames 2 and 5). Reinforcement details of members are available in Appendix B.

The performance-based plus design (Building 2C) was prepared as outlined by the PEER TBI team. It was determined that the Building 2B design was inadequate for the serviceability demands resulting from the 43-year return period earthquake with 2.5% viscous damping. Rather than strengthen the system, the designers opted to use the alternative approach, permitted in the *TBI Guidelines*, whereby the building design was checked for serviceability using nonlinear dynamic analysis. Because the building passed all performance checks, no redesign was necessary; therefore it was unnecessary to develop a new design for Building 2C as Building 2B satisfied all requirements (see the design report in Appendix B).

4.3 DEVELOPMENT OF THE STRUCTURAL ANALYSIS MODELS FOR BUILDING 2

A uniform modeling procedure was established so that engineering demand parameters (EDPs) for all models (Buildings 1A, 1B, 1C, 2A, and 2B) could be compared. Stiffness modifiers (given in Appendix B) were used to determine the force-displacement relationships. Expected material strengths of $1.3 f'_c$ and $1.17 f_y$ were used for concrete and reinforcing steel, respectively.

4.3.1 Modeling of Building 2A

The three-dimensional nonlinear model was constructed using Perform-3D to represent the lateral force resisting system of the building, i.e., the gravity system was excluded. The seismic

mass was assigned as described in Section 4.3.1.8, and a rigid diaphragm was incorporated by slaving the horizontal translation degrees of freedom for each floor above the ground level. For the floors below ground, the diaphragm system was modeled using a finite element (FE) mesh. The core wall and the moment frames extended down to the foundation level. The foundation of the building was modeled as rigid, using lateral and vertical supports at the top of the foundation. P-delta effects were taken into account in the model by creating a dummy column with no lateral stiffness subjected to an axial load of $(P=D+0.25L)$ and by slaving the column ends with the other nodes at each level.

4.3.1.1 Core Wall Modeling

Nonlinear vertical fiber elements representing the expected behavior of the concrete and steel were used to model the core wall. For the fiber concrete elements, only confined concrete with the expected strength was used, i.e., the unconfined concrete cover was neglected. The concrete stress-strain relationship was based on the modified Mander model for confined concrete [Mander et al. 1988], whereby the tension strength of concrete is neglected (Figure 4.6). Because Perform-3D requires that the concrete stress-strain relation be defined by four linear segments, four control points were selected to approximate the relation required by the Mander model:

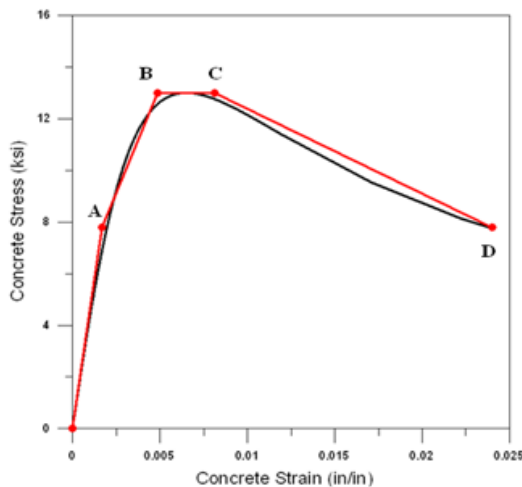

$$A: (0.6f_{cc}/E_c, 0.6f_{cc})$$

$$B: (0.75\varepsilon_{cc}, f_{cc})$$

$$C: (1.25\varepsilon_{cc}, f_{cc})$$

$$D: (0.024\varepsilon_{cc}, 0.6f_{cc})$$

Figure 4.6 Concrete stress-strain relationship.

Because the core walls were modeled using fiber elements, the effective stiffness EI_{eff} is not assigned explicitly; the EI_{eff} decreased as the strains on the fiber elements increased. The shear behavior was modeled inelastic with a shear modulus $G=2E_c$, where E_c is the expected elastic modulus, which can be determined using the following equations for the expected concrete strength:

$$E_c = 57000\sqrt{f'_c} \quad \text{for } f'_c \leq 6000 \text{ psi}$$

$$E_c = 40000\sqrt{f'_c} + 1 \times 10^6 \quad \text{for } f'_c > 6000 \text{ psi (ACI-373R-92)}$$

Inelastic shear material was defined using an elastic-perfectly plastic stress-strain curve in which strength loss was neglected (Figure 4.7). The ultimate shear strength, V_{ult} , was defined as $1.5V_n$, where V_n is the nominal shear capacity of the shear wall based on ACI 318-08 as follows:

$$V_n = (\alpha_c \sqrt{f'_c} + \rho_t f_y) \text{ psi (ACI 318-08 §21.9.4.1)}$$

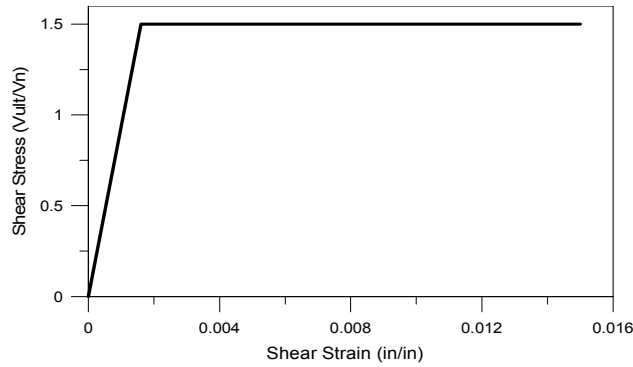

Figure 4.7 Inelastic shear stress-strain relationship.

The steel stress-strain relationship is based on the material specifications for A706 steel. The steel was modeled with expected yield strength of 70 ksi and an ultimate strength of 105 ksi, as shown in Figure 4.8. The post-yield stiffness and cyclic degradation of reinforcing steel was modeled according to Orakcal and Wallace [2006] and adjusted to match the lateral load versus top displacement curve. The cyclic degradation parameters are available in Appendix B.

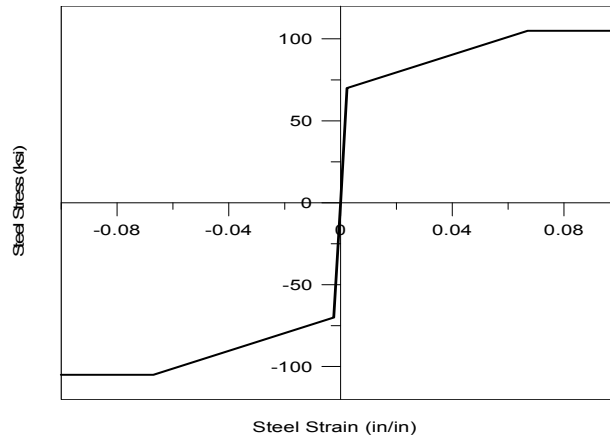

Figure 4.8 Inelastic steel stress-strain relationship.

4.3.1.2 Coupling Beam Modeling

The coupling beams were defined as elastic beam elements with a nonlinear displacement shear hinge at the mid-span of the beam. The shear displacement hinge behavior was based on test results by Naish et al. [2009] and represents a tri-linear force-rotation relationship with flexural stiffness of $EI_{\text{eff}} = 0.2EI_g$, expected yield shear strength of $V_{y_{\text{exp}}} = 2A_s * 1.17 f_y \sin(\alpha)$ expected ultimate shear strength of $V_{u_{\text{exp}}} = 133V_{y_{\text{exp}}}$ and expected residual strength, $V_{r_{\text{exp}}} = 0.25V_{u_{\text{exp}}}$ (see Figure 4.9). Cyclic energy dissipation factors are shown in Table 4.3. Detailed information on coupling beam design is available in the Appendix B.

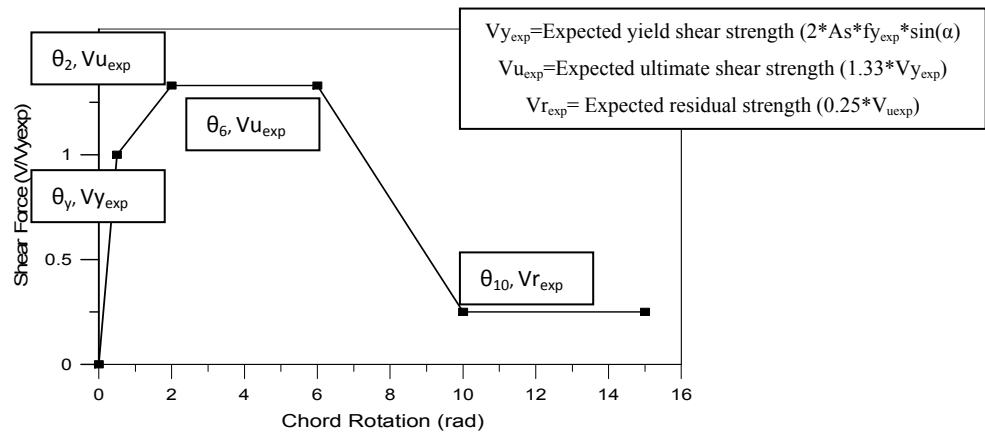
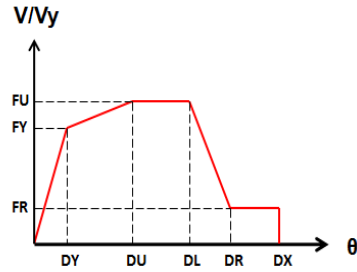

Figure 4.9 Shear displacement hinge backbone curve.

Table 4.3 Cyclic degradation parameters.

DY	0.5
DU	0.45
DL	0.4
DR	0.35
DX	0.35



4.3.1.3 Moment Frame Beam Modeling

The moment frame beams were defined as elastic beam elements with nonlinear rotation hinges with rigid end zones at each end. The elastic portion of the beam was modeled with the cross-section properties and the stiffness modification factors such that $EI_{\text{eff}} = 0.2EI_g$ (flexural), $GA = 1.0GA_g$ (shear). The nonlinear moment-rotation hinges, which were defined based on Popov et al. [1972] to represent post-yield stiffness, were modeled as tri-linear backbone curves including cyclic degradation but neglecting strength loss. Figure 4.10 shows a typical backbone curve used for beam moment-rotation hinges. Further details are available in Appendix B.

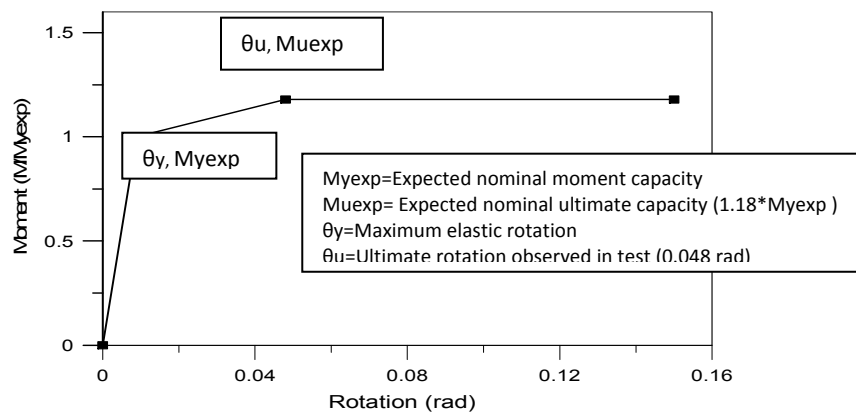

Figure 4.10 Moment-rotation hinge backbone curve.

4.3.1.4 Moment Frame Column Modeling

The moment frame columns were defined as elastic column elements with plastic hinges with rigid end zones at each end. The elastic portion of the column was modeled with cross-section

dimensions and stiffness modification factors of $EI_{\text{eff}} = 0.7EI_g$ (flexural), $GA = 1.0GA_g$ (shear). To define a column plastic hinge, a moment-axial capacity interaction curve was calculated using the expected material properties of column. The backbone curve was elastic-perfectly plastic, neglecting strength loss and cyclic degradation. Details on column modeling are available in Appendix B.

4.3.1.5 Slab Modeling

Slabs at the ground level and below are modeled as elastic shell elements with stiffness values of $EI_{\text{eff}} = 0.25EI_g$ (flexural) and $GA = 0.5GA_g$ (shear). All slabs have a specified concrete strength of $f'_c = 5$ ksi and they are modeled using the expected concrete strength of $f'_c = 6.5$ ksi and the associated modulus of elasticity. Shear modulus G is calculated using a Poisson's ratio, $\nu = 0.2$.

4.3.1.6 Basement Wall Modeling

Basement walls were modeled as elastic finite elements with stiffness values of $EI_{\text{eff}} = 0.8EI_g$ (flexural) and $GA = 0.8GA_g$ (shear). Therefore, the elastic modulus and the shear modulus were taken as $E = 0.8E_{\text{exp}}$ and $G = 0.8G_{\text{exp}}$ ($G = 0.16E_{\text{exp}}$), respectively.

4.3.1.7 Damping

Rayleigh damping was used for the nonlinear response-history analyses. The damping curve—shown in Figure 4.11—was defined based on the damping of 2.5% of critical damping at a period of 1 sec and at a period of 5 sec. T1, the fundamental period, was 4.456 sec and the constants α and β were calculated automatically by Perform-3D

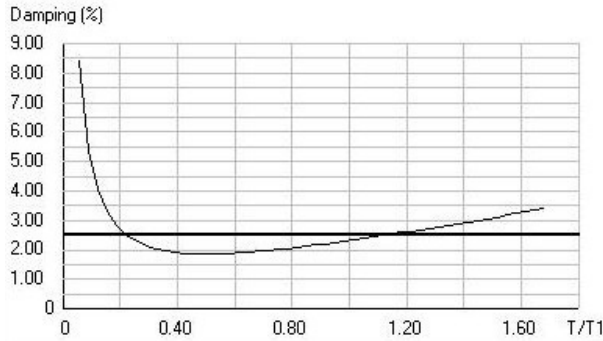

T/T1	Damping (%)
0.224	2.5
1.122	2.5

Figure 4.11 Rayleigh damping as defined by Perform-3D.

4.3.1.8 Masses

The seismic mass was lumped at the center of mass of each floor above ground level in terms of dead load and the associated rotational moment of inertia. The mass at the ground level was assigned as distributed mass and kept the same for all the levels below ground.

4.3.1.9 Modeling of Building 2B

Considering the uniform modeling procedure, the previously mentioned modeling assumptions were applied to model Building 2B. Members were updated based on the performance-based design dimensions and the stiffness factors were modified if deemed necessary.

4.4 BUILDING 2: ANALYSIS RESULTS AND DISCUSSION

4.4.1 Overall Behavior

4.4.1.1 Building 2A

The mean value of fifteen floor displacements with the standard deviation for five hazard levels is shown in Figure 4.12. As a result of the basement walls and slabs, displacement below grade was practically zero, however it increased linearly from grade to the roof level where the maximum displacement occurred. The OVE level showed the most dispersion in displacement and a larger difference between the two directions compared to the other hazard levels. Maximum roof displacement was observed to be about 80 in. with a standard deviation of 20 in.

Interstory drift profiles (Figure 4.13) show that the maximum average interstory drift for the OVE level was slightly higher than 2% in East-West direction and close to 1.5% in North-South direction, whereas the peak drift approached 0.3% for serviceability levels in both directions. In all cases, the peak drift values occurred around the thirtieth floor and never exceeded the acceptable limit: 0.03 for the MCE, 0.02 for the DBE, and 0.005 for the SLE levels. For comparison purposes, an acceptable limit of 0.03 was used for OVE as well, even though a limit is not specified for this level in the code. The serviceability level drift is obviously the most critical case since the peak drifts approached the limit more often in that case.

As shown in Figure 4.14, floor accelerations indicate that fundamental modes were not excited under the SLE—note the very low response associated with the tower as shown in Figure 4.14(d)—although significant response of the stiff podium was observed. For the OVE and MCE events [Figures 4.14(a) and (b), respectively], accelerations were limited by yielding, with maximum values of approximately 0.5g over a majority of the tower.

4.4.1.2 Building 2B

The same behaviors were observed for Building 2B with 15% less displacement and drift. The results are illustrated in Figures 4.15-4.17.

Floor Displacements

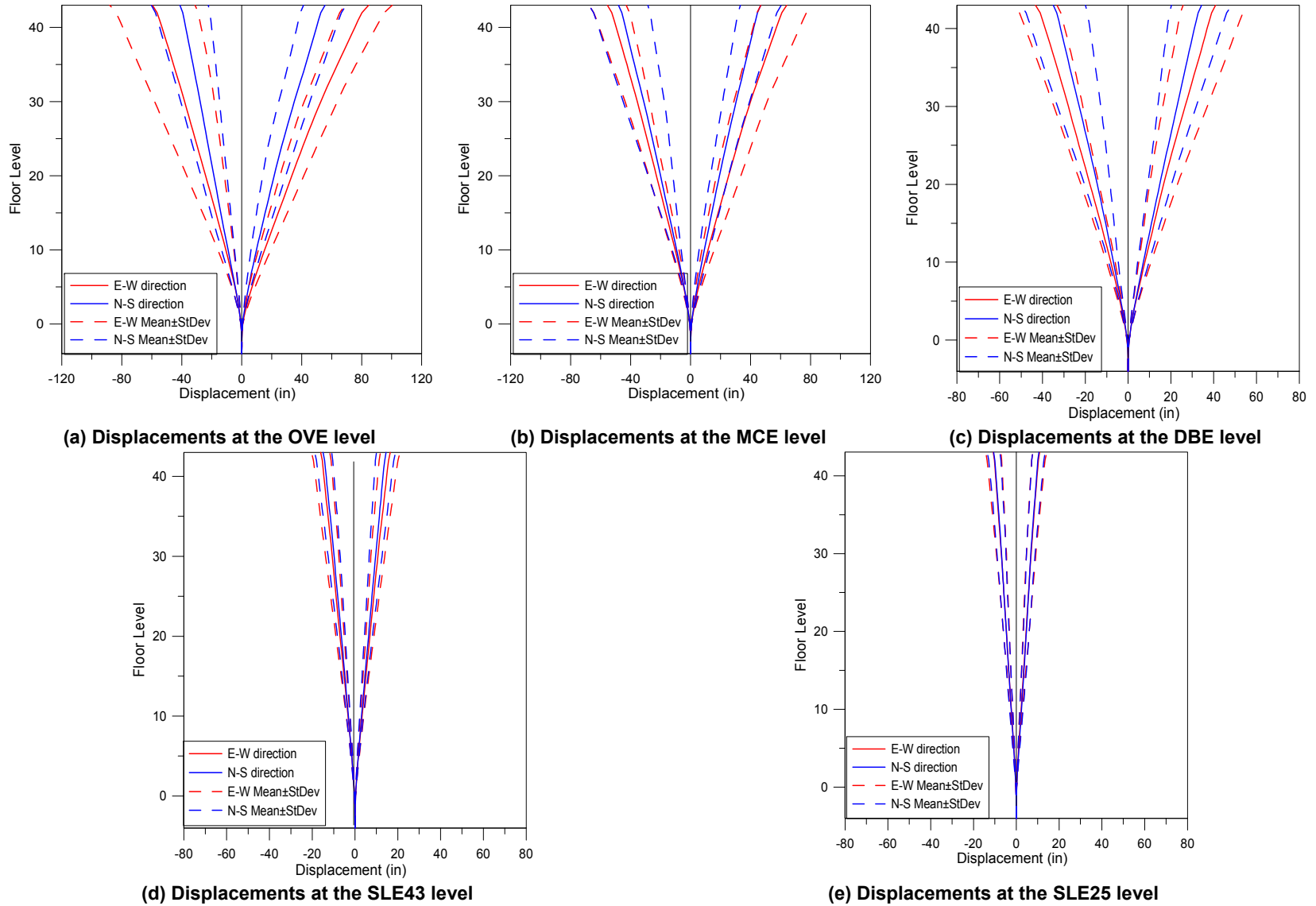

Figure 4.12 Building 2A: story displacements under various hazard levels.

Interstory Drifts

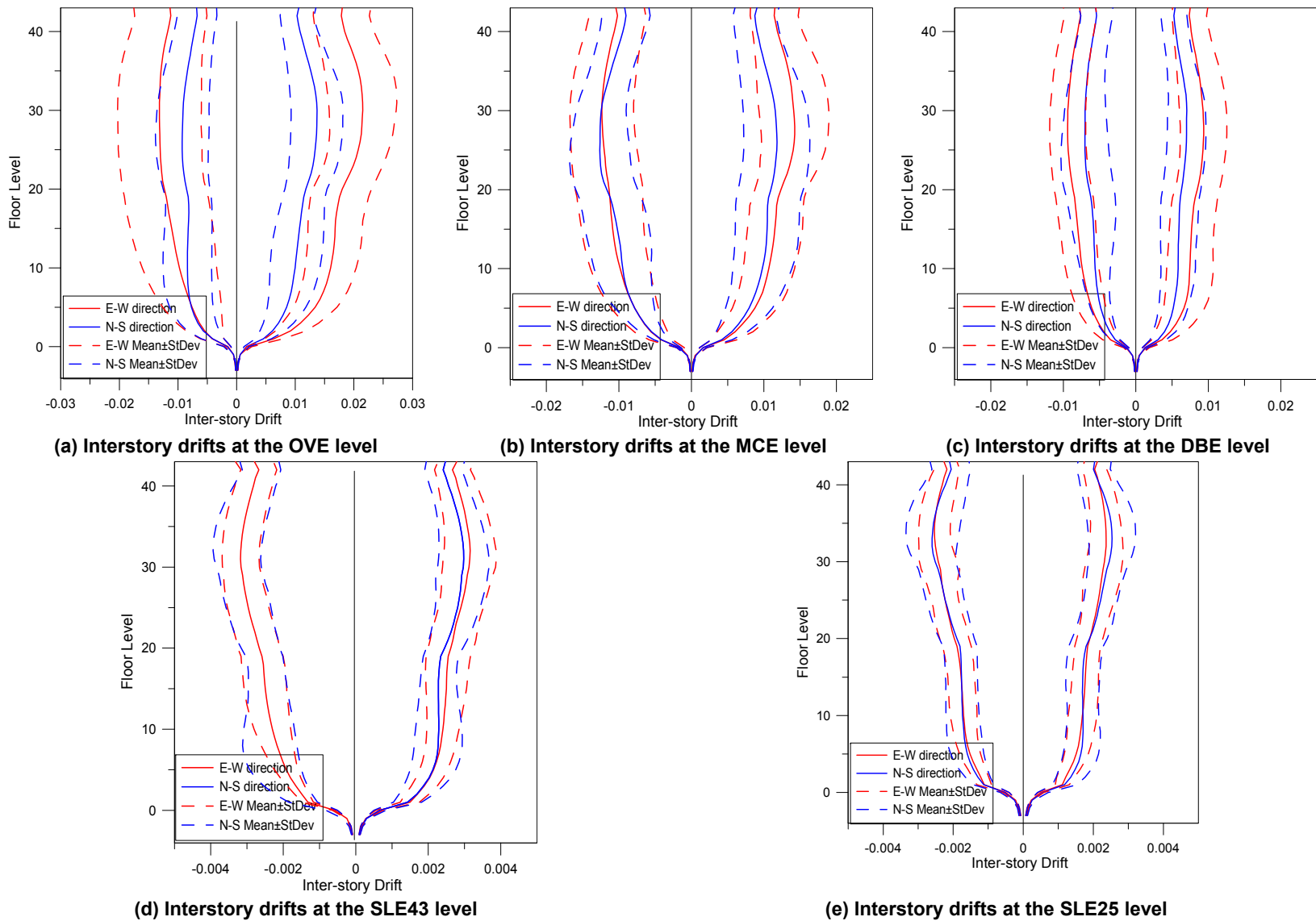

Figure 4.13 Building 2A: interstory drifts under various hazard levels.

Floor Accelerations

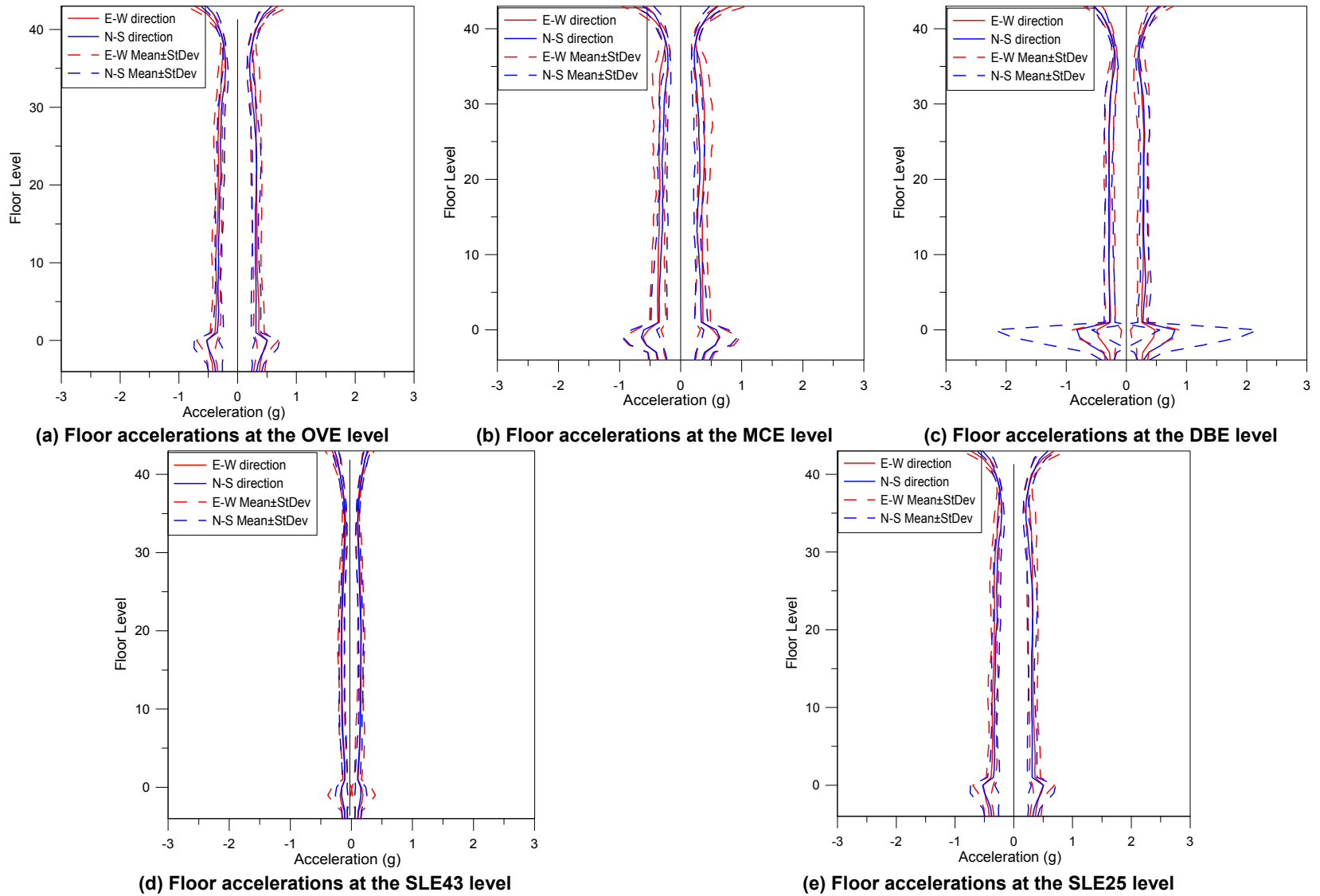
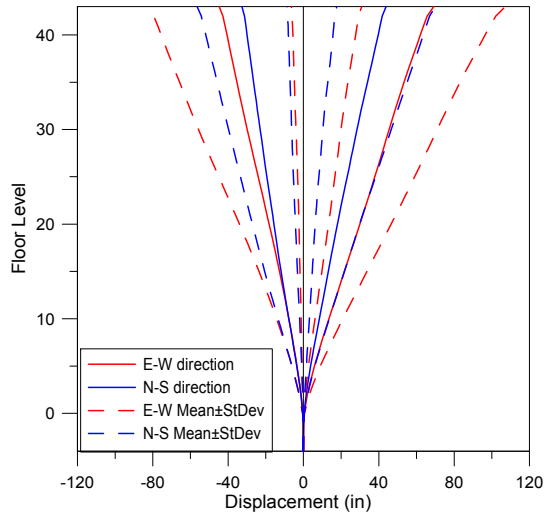
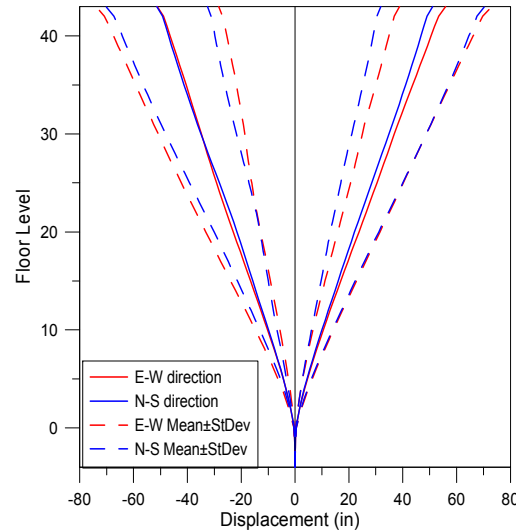

Figure 4.14 Building 2A: floor accelerations under various hazard levels.

Floor Displacements



(a) Displacements at the OVE level



(b) Displacements at the MCE level

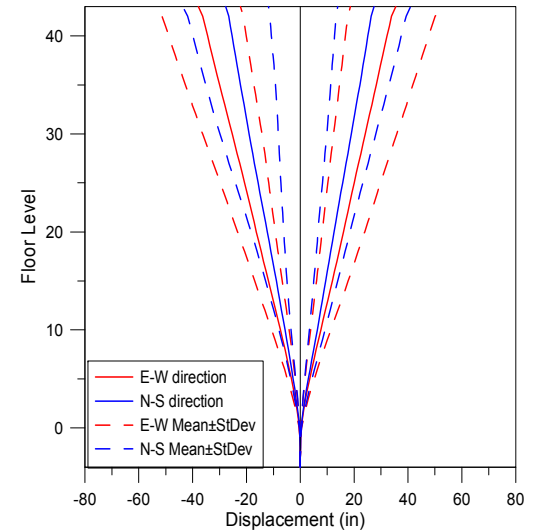

(c) Displacements at the DBE level

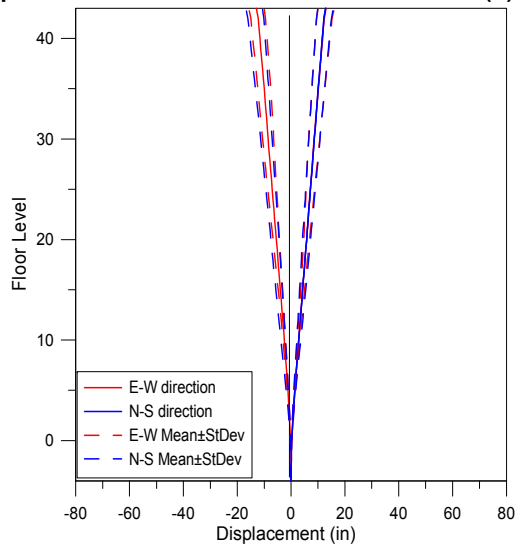

(d) Displacements at the SLE43 level

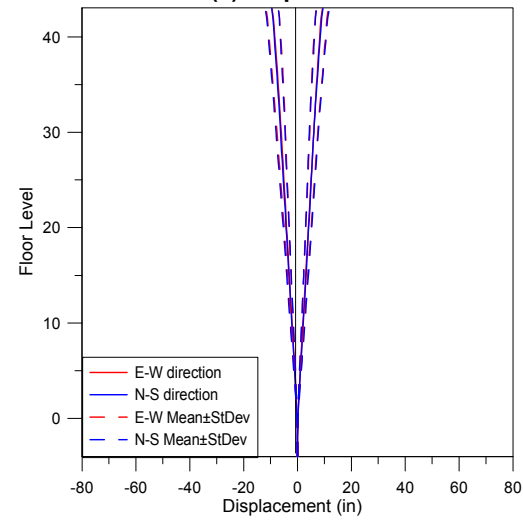

(e) Displacements at the SLE25 level

Figure 4.15 Building 2B: story displacements under various hazard levels.

Interstory Drifts

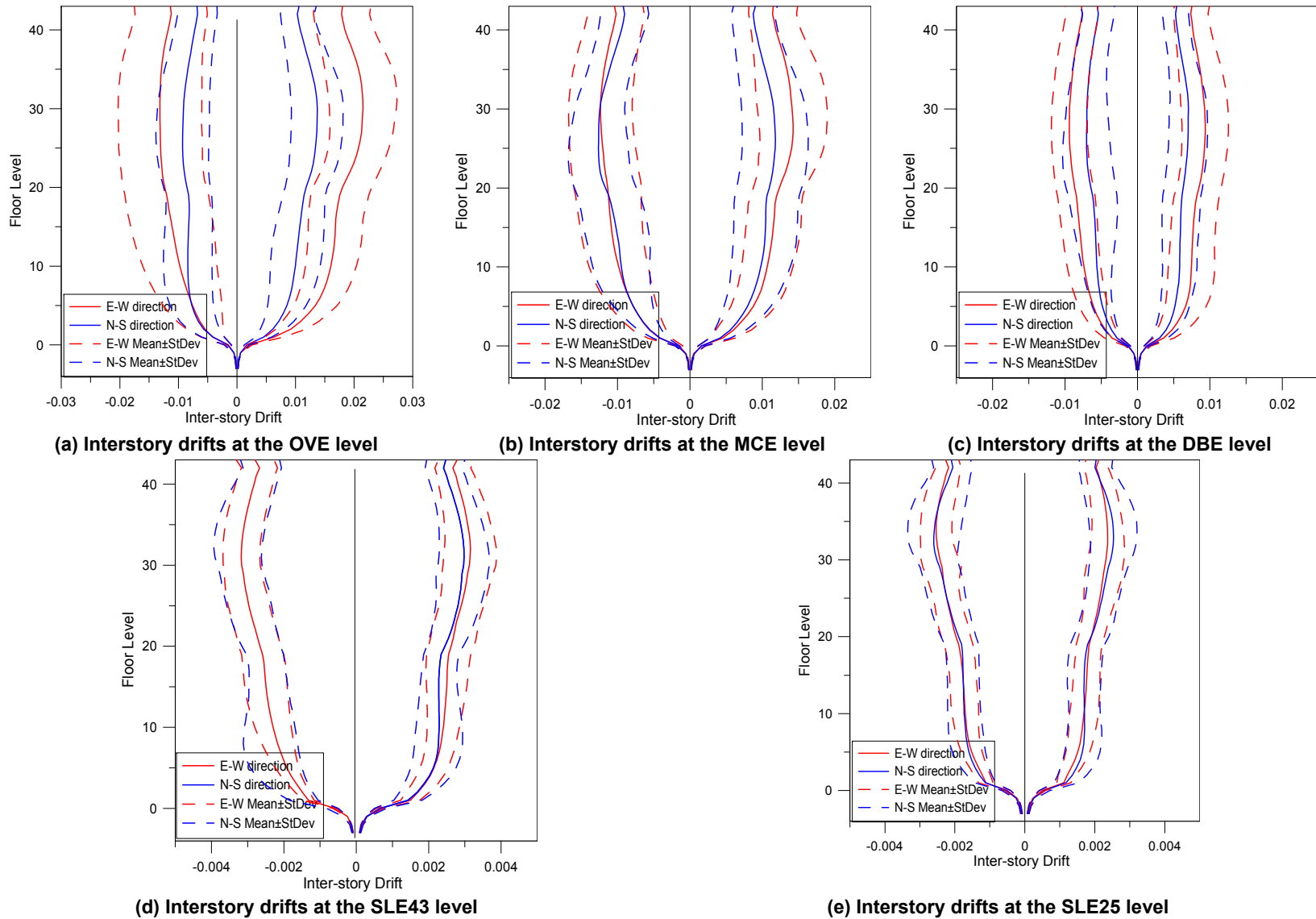

Figure 4.16 Building 2B: interstory drifts under various hazard levels.

Floor Accelerations

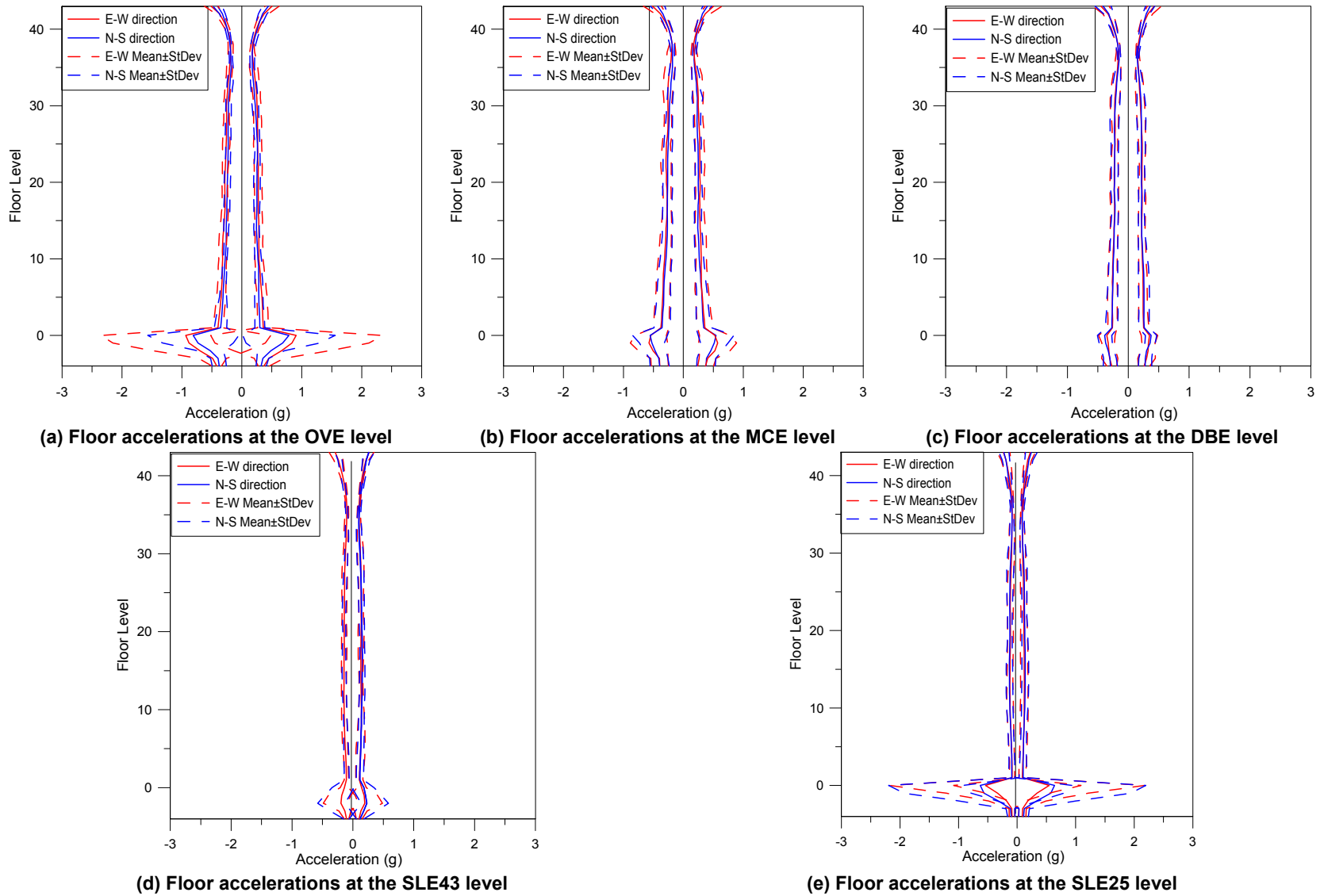

Figure 4.17 Building 2B: floor accelerations under various hazard levels

4.4.2 Core Shear Wall Behavior

4.4.2.1 Building 2A

To assess building response, peak values of shear and moment were analyzed over the core wall height; results are shown in Figures 4.20-4.22. A large increase in core wall shear force was noted at ground level due to the below-grade podium, which was much stiffer than the tower. From ground to roof level, a linear profile is observed for each hazard level, indicating first-mode dominant response. Studies by Salas [2009] have shown that applying a linear model at upper levels results in significant higher mode contributions to wall moment and shear; therefore, nonlinear modeling was incorporated over the full height of the wall. Modest flexural yielding in upper levels of the wall reduced the impact of higher modes. For all hazard levels, the peak wall shear stresses were much less than the ACI 318-08 limit of $8\sqrt{f'_c}$, except for the OVE level, where the shear stress reached the limit around ground level (Figure 4.21).

Core wall strains were calculated at each node of each wall pier (Figures 4.24-25) and plotted over the wall height. Calculations were based on the vertical nodal displacements and geometrical properties. Considering the deformed shape of a wall pier, as shown in Figure 4.18,

strain in the left and right side of the wall was obtained as follows: $\varepsilon_{(1-3)} = \frac{(\Delta_{z1} - \Delta_{z3})}{H_w}$ and

$\varepsilon_{(2-4)} = \frac{(\Delta_{z2} - \Delta_{z4})}{H_w}$ respectively. Figures 4.25 and 4.26 show the compression and tension strain

profile of each direction wall. Because the maximum responses occurred in OVE level ground motions, compression and tension strains are presented only for this hazard level.

As shown in Figures 4.24 and 4.25, all core wall piers experienced yielding around the ground and fifth floors, whereas only West and South wall piers yielded in the upper stories. For the highest intensity level (OVE), wall tension strains did not exceed 0.01, and concrete compression strains were fairly low (<0.002).

Coupling beam rotations (Figure 4.27) were examined at the OVE to assess possible damage. Peak rotations of 0.015 and 0.02 were observed in the N-S and E-W directions, respectively, although the serviceability level rotations were much smaller (<0.002 radians).

According to the fragility curves developed by Naish [2010], no repair was likely necessary given the small rotations (Figure 4.19).

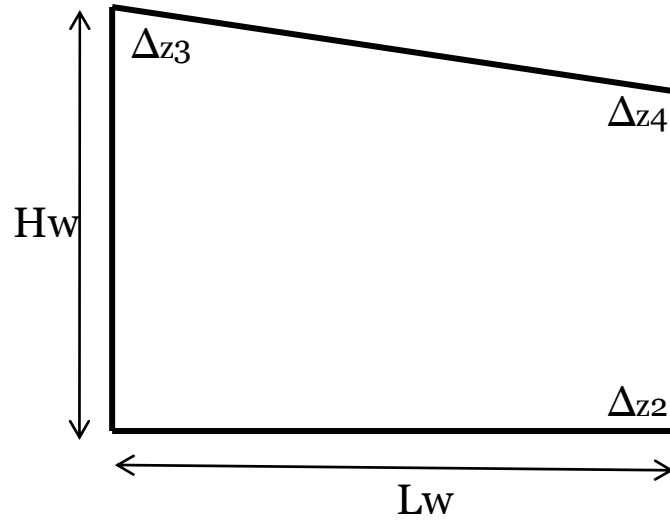

Figure 4.18 Elevation view of deformed wall segment.

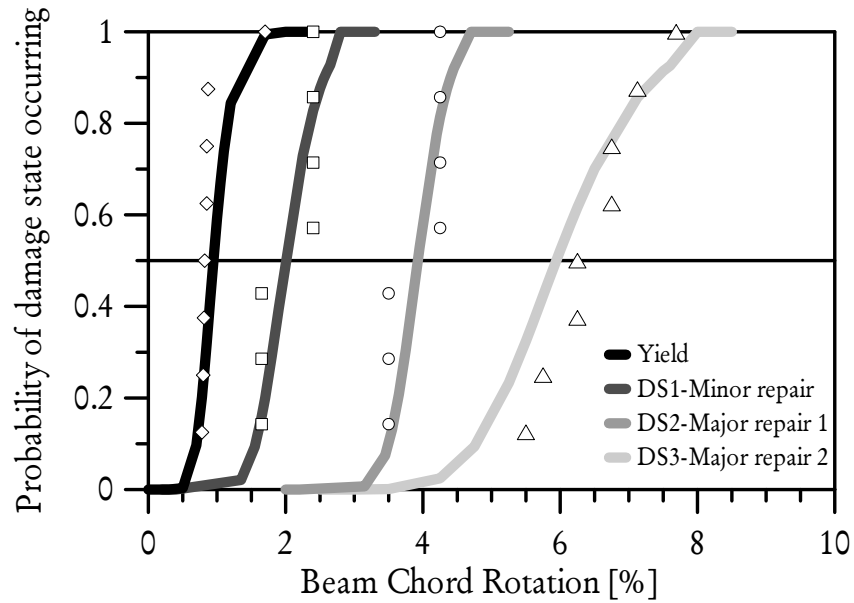
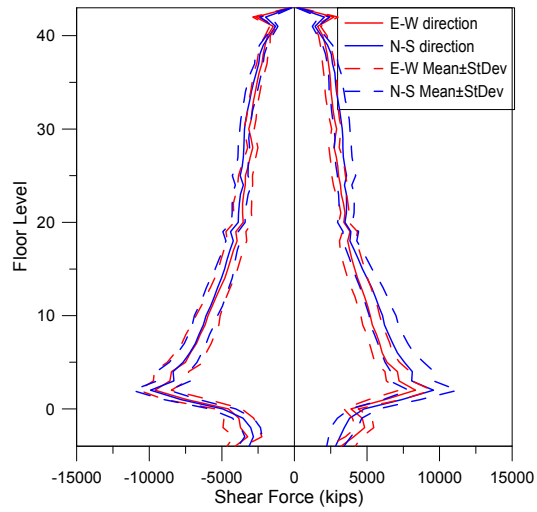
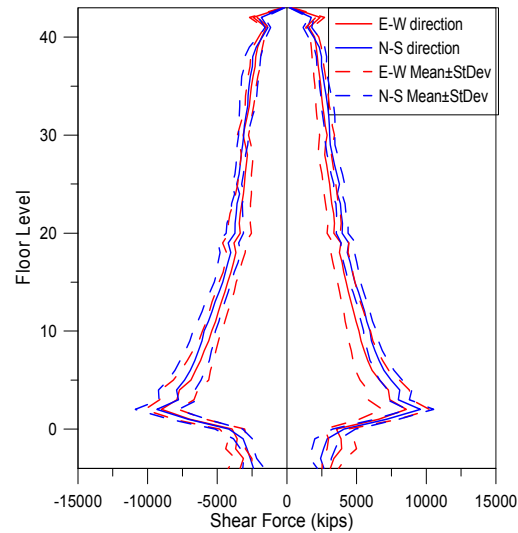

Figure 4.19 Fragility curves for diagonally reinforced concrete coupling beams at high aspect ratio [Naish 2010].

Shear Force



(a) Shear forces at the OVE level



(b) Shear forces at the MCE level

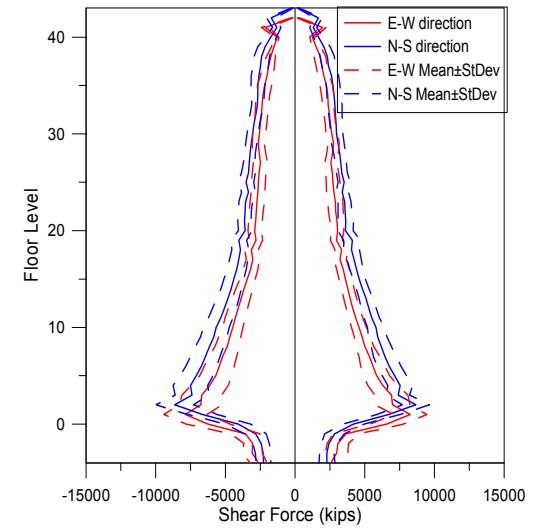

(c) Shear forces at the DBE level

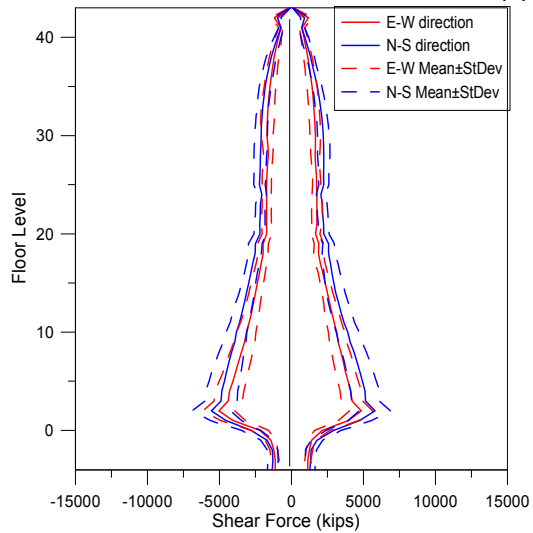

(d) Shear forces at the SLE43 level

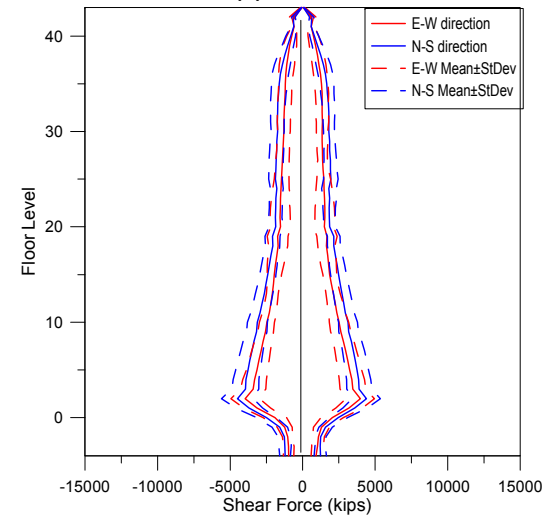

(e) Shear forces at the SLE25 level

Figure 4.20 Core wall shear forces under various hazard levels.

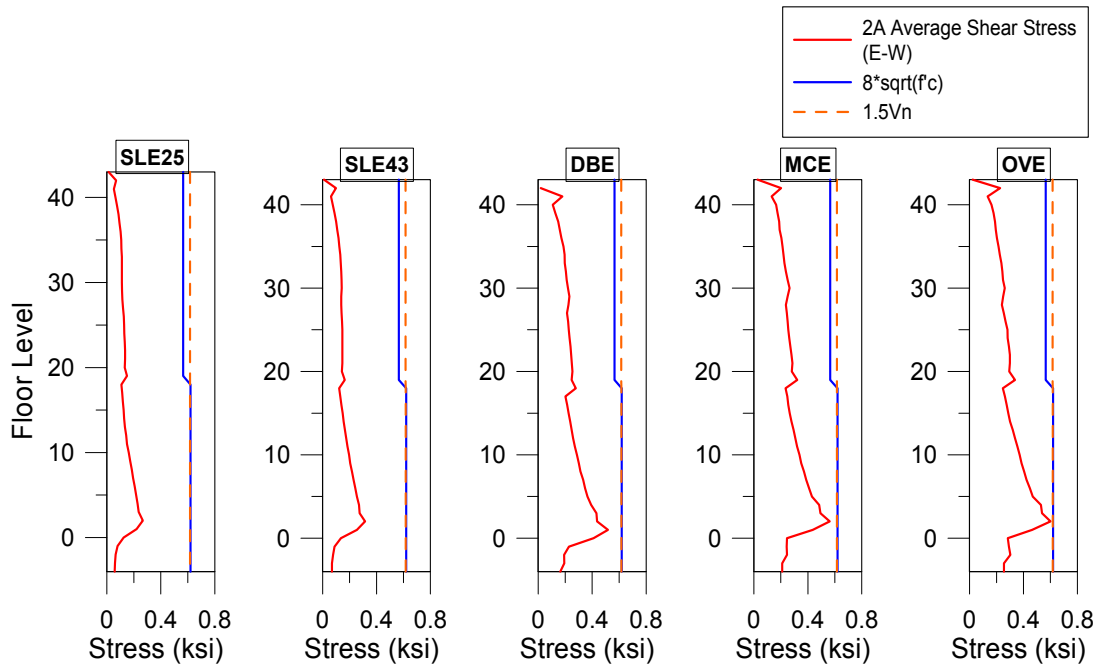

Figure 4.21 Average shear stress profiles of the core wall.

Core Wall Moments

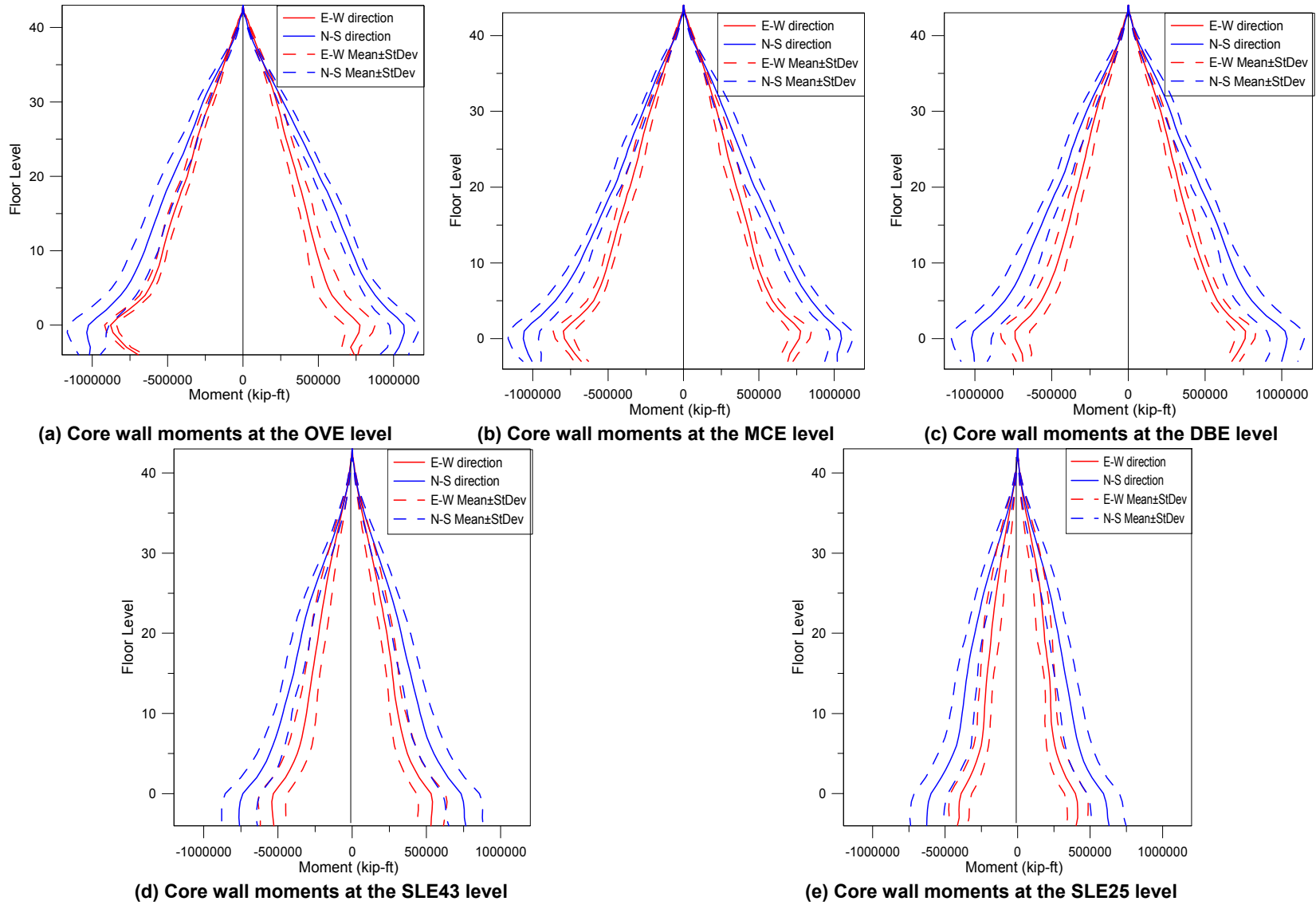

Figure 4.22 Core wall shear forces under various hazard levels.

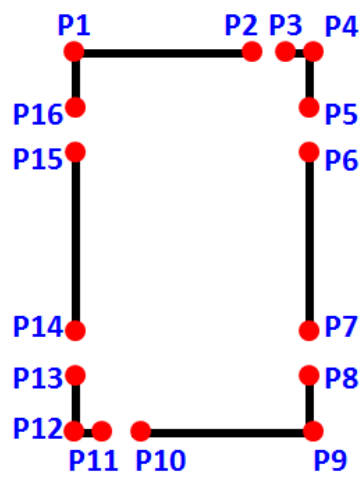

Figure 4.23 Locations of nodes used in strain calculations for the core wall.

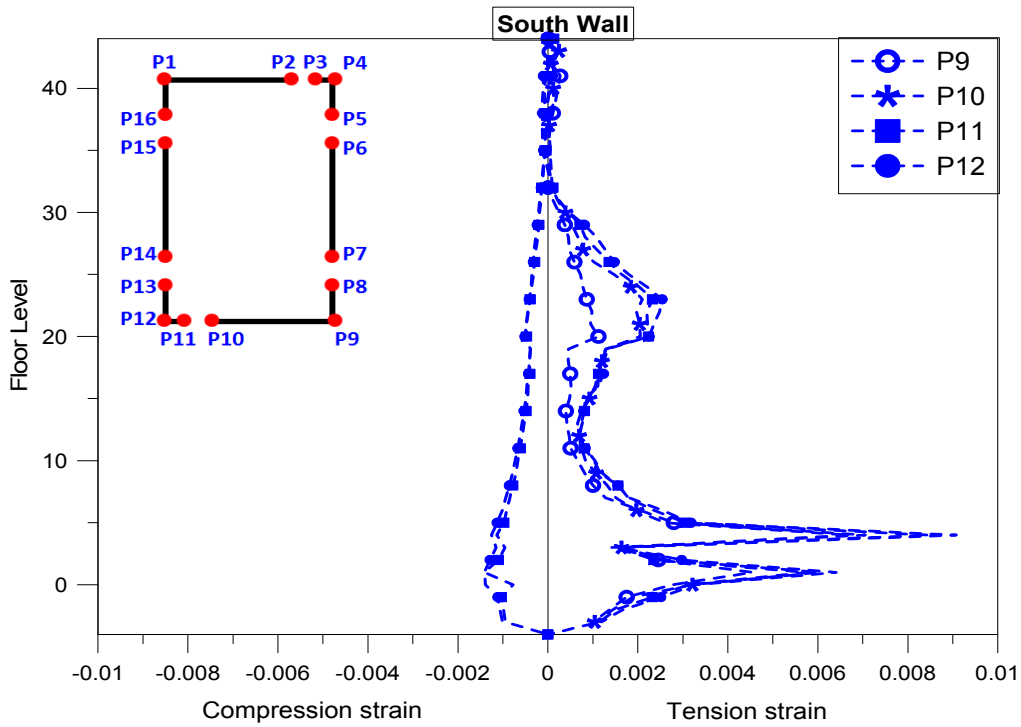
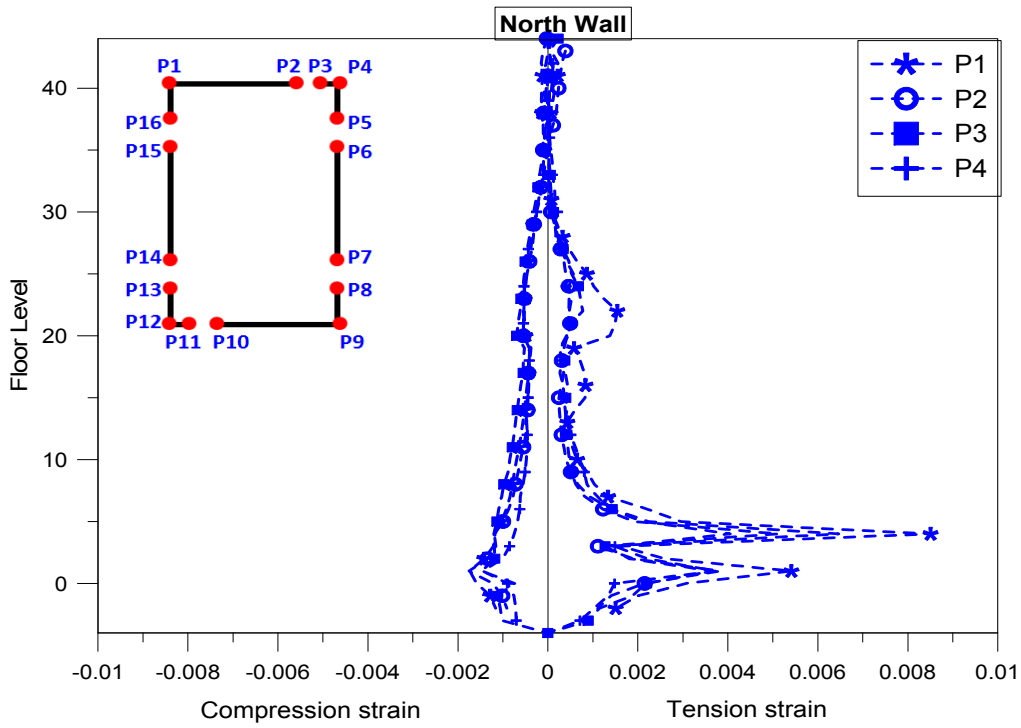

Figure 4.24 North and South wall strains at the OVE level.

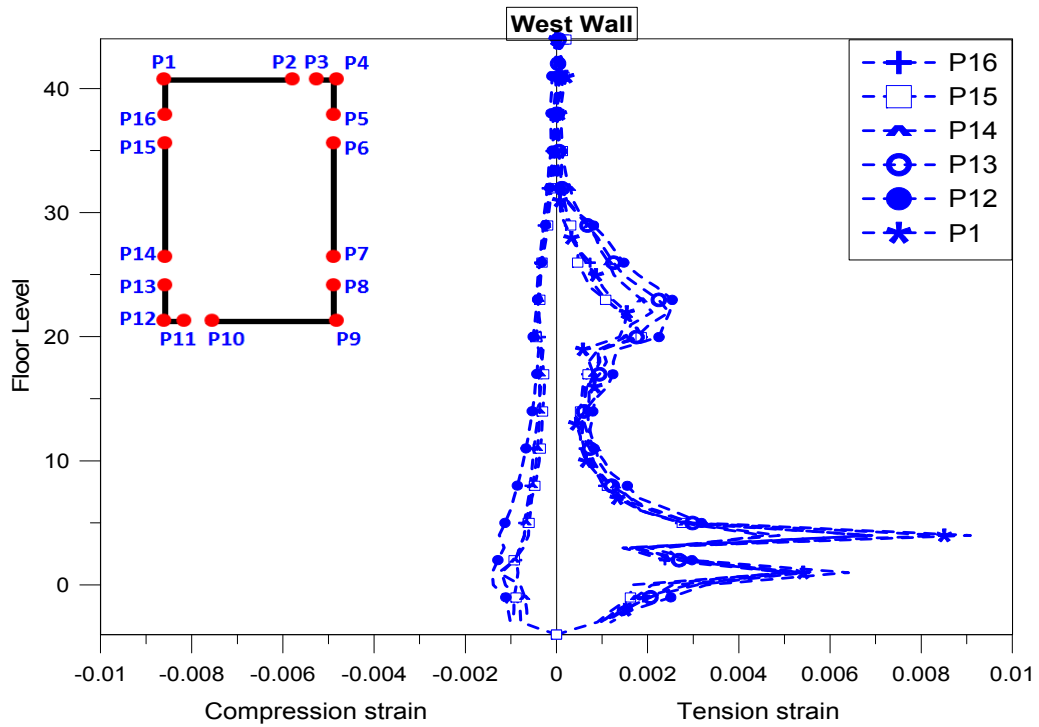
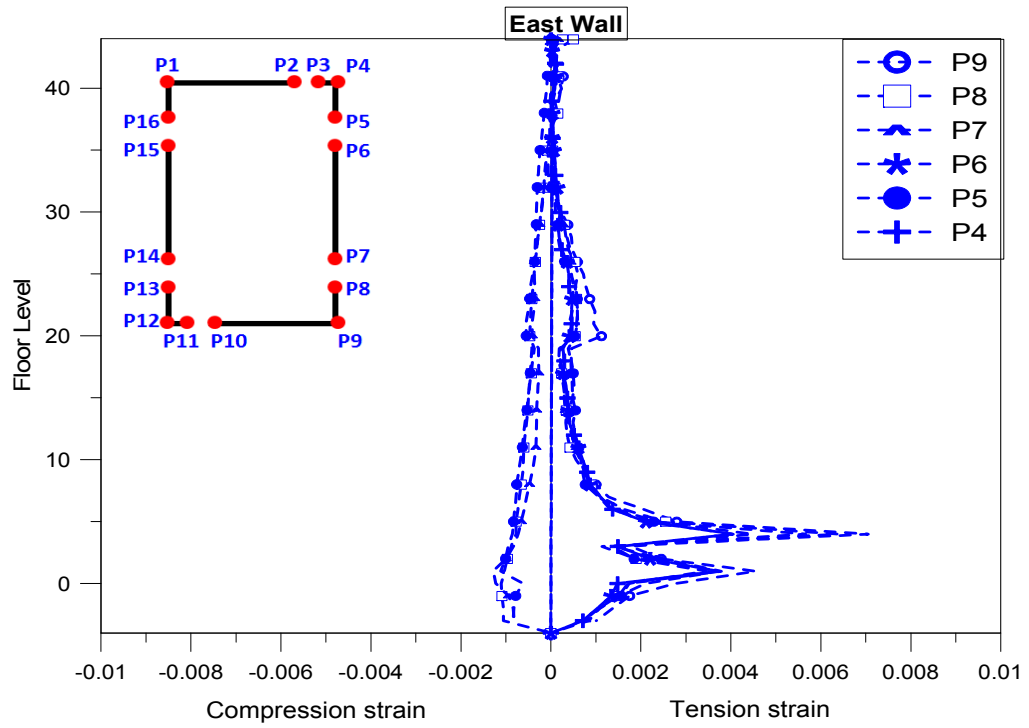

Figure 4.25 East and West wall strains at the OVE level.

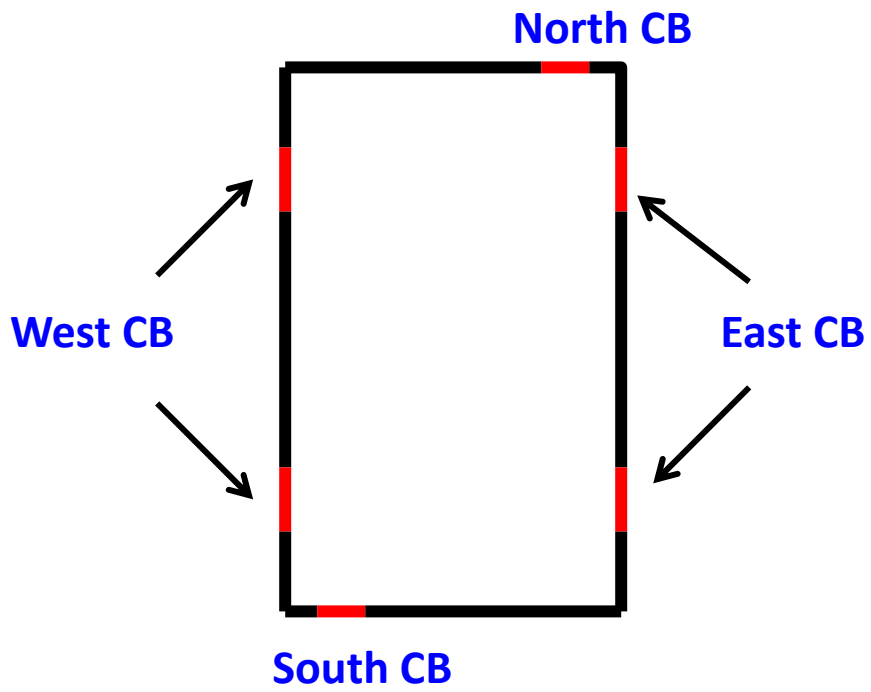

Figure 4.26 Coupling beam locations.

Coupling Beam Rotations

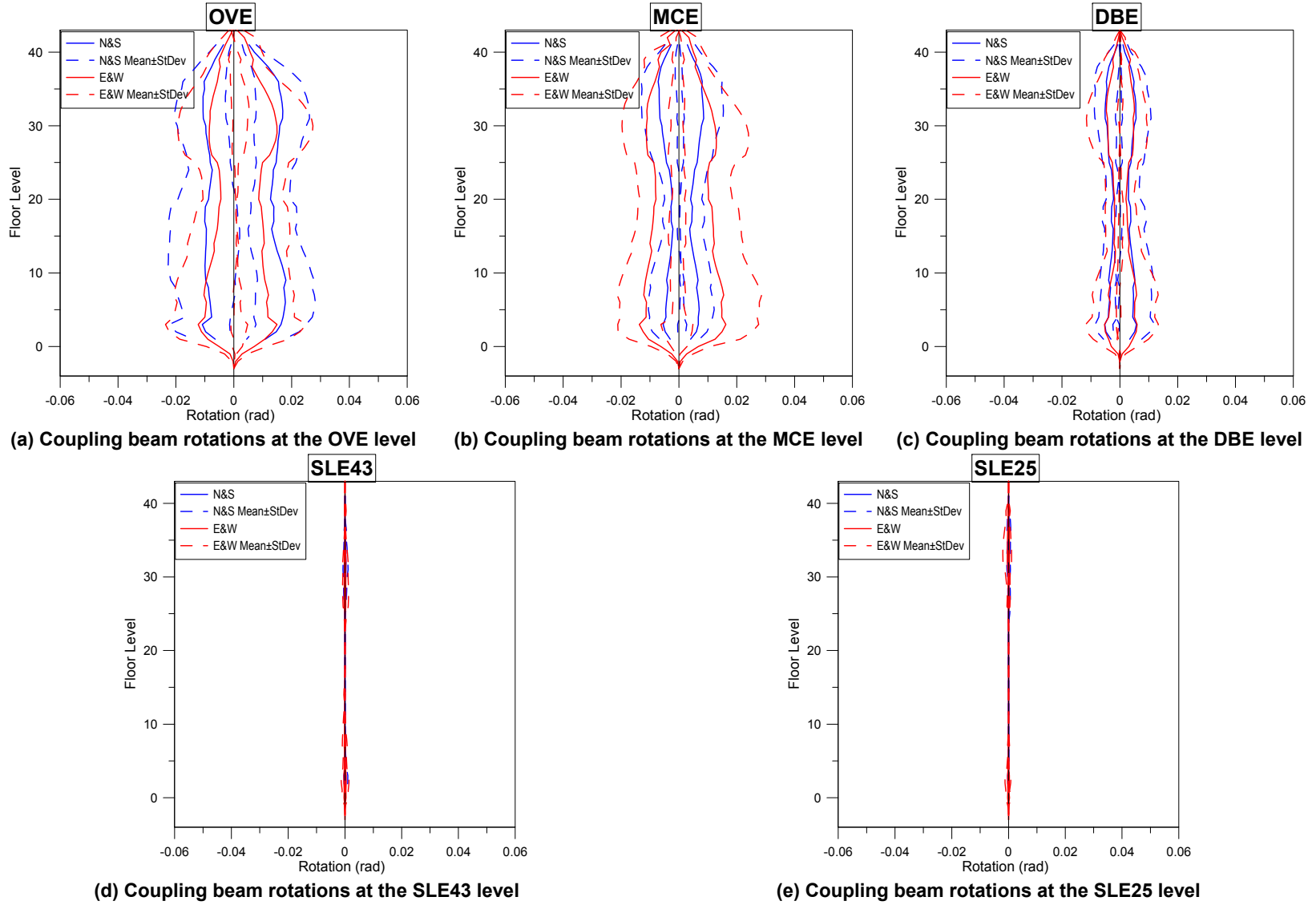

Figure 4.27 Coupling beam rotations under various hazard levels.

4.4.2.2 Building 2B

The response quantities analyzed for Building 2B were applied to for the same ground motions (Figures 4.28-4.33). Shear and moment profiles and core wall strains were similar to those reported for Building 2A; however, because thicker walls were used for Building 2B, modestly lower shear forces/stresses and core wall strains and modestly higher coupling beam rotations were computed (for all hazard levels). The peak values over the building height of the median and median plus one standard deviation for coupling beam rotations of 0.03 and 0.05, are still well below the limiting value of 0.06. Based on the fragility relations developed by Naish [2010], damage is expected to be limited and some epoxy injection repair might be needed at some levels (Figure 4.19).

Coupling Wall Shears

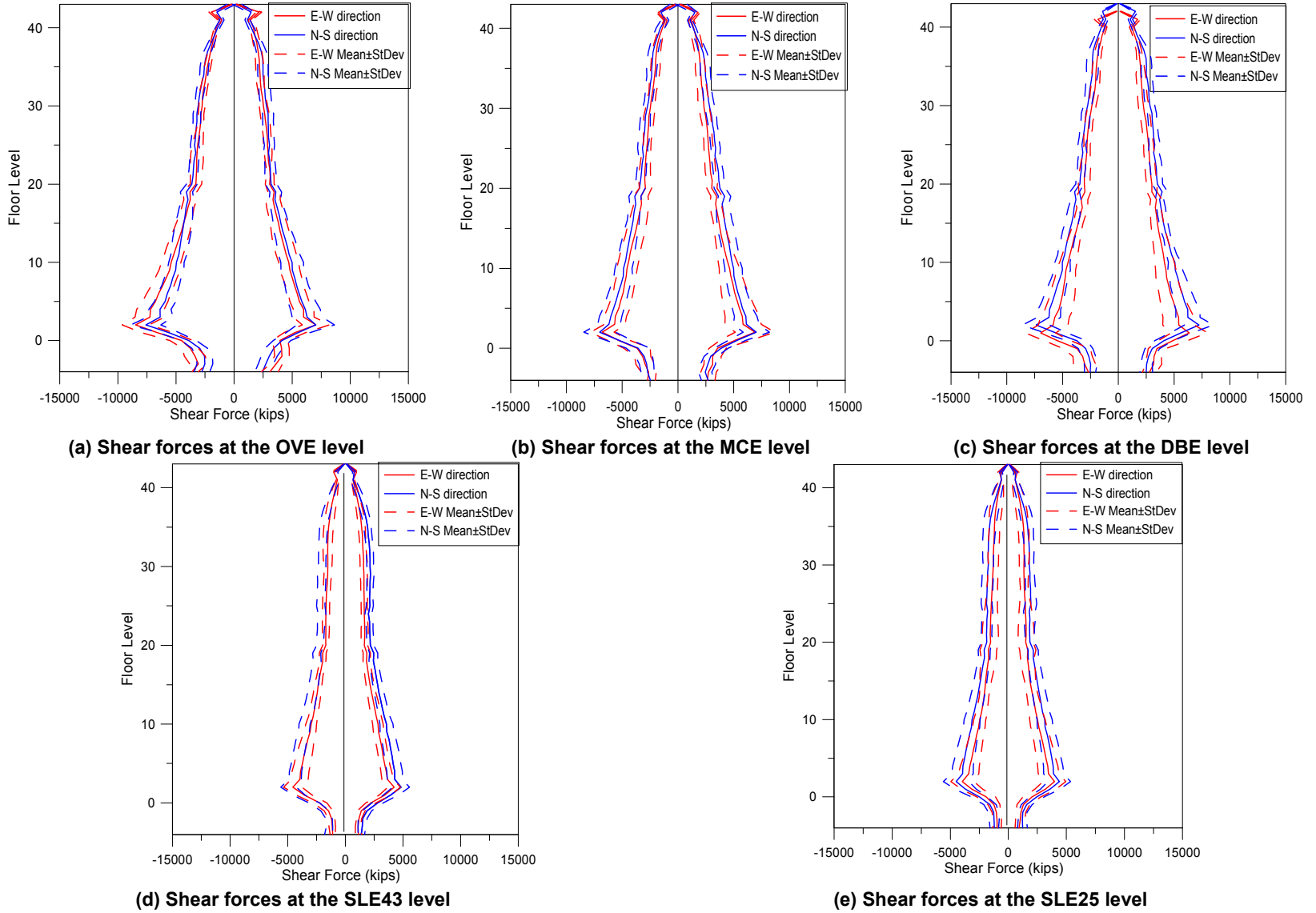

Figure 4.28 Core wall shear forces under various hazard levels.

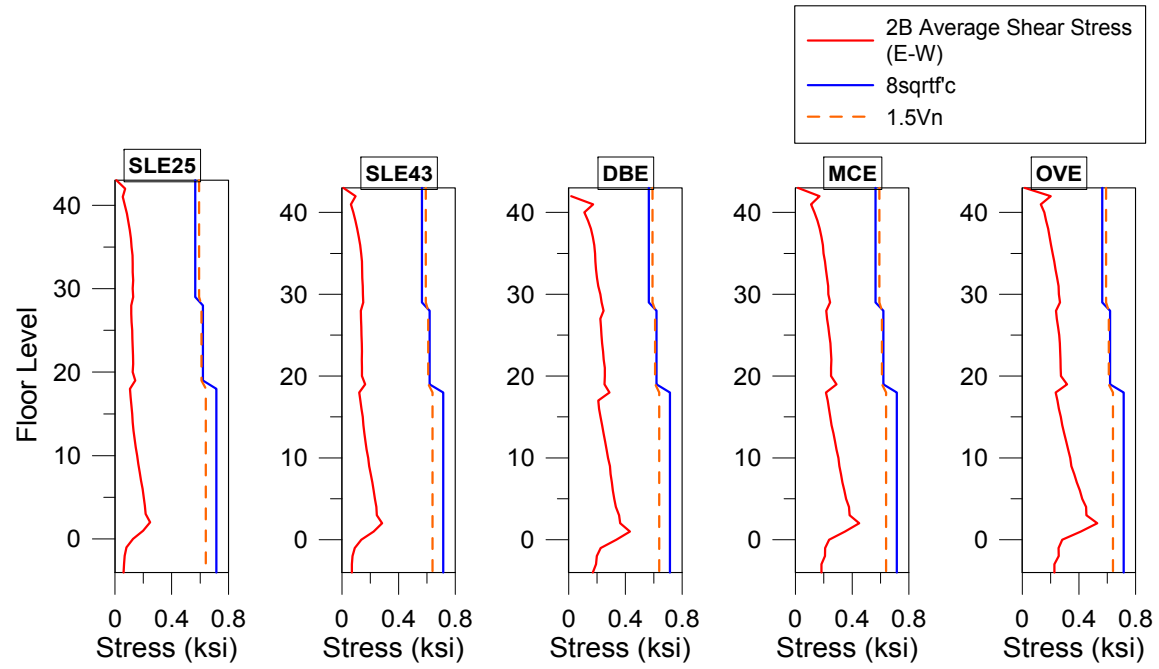

Figure 4.29 Average shear stress profiles of the core wall.

Core Wall Moments

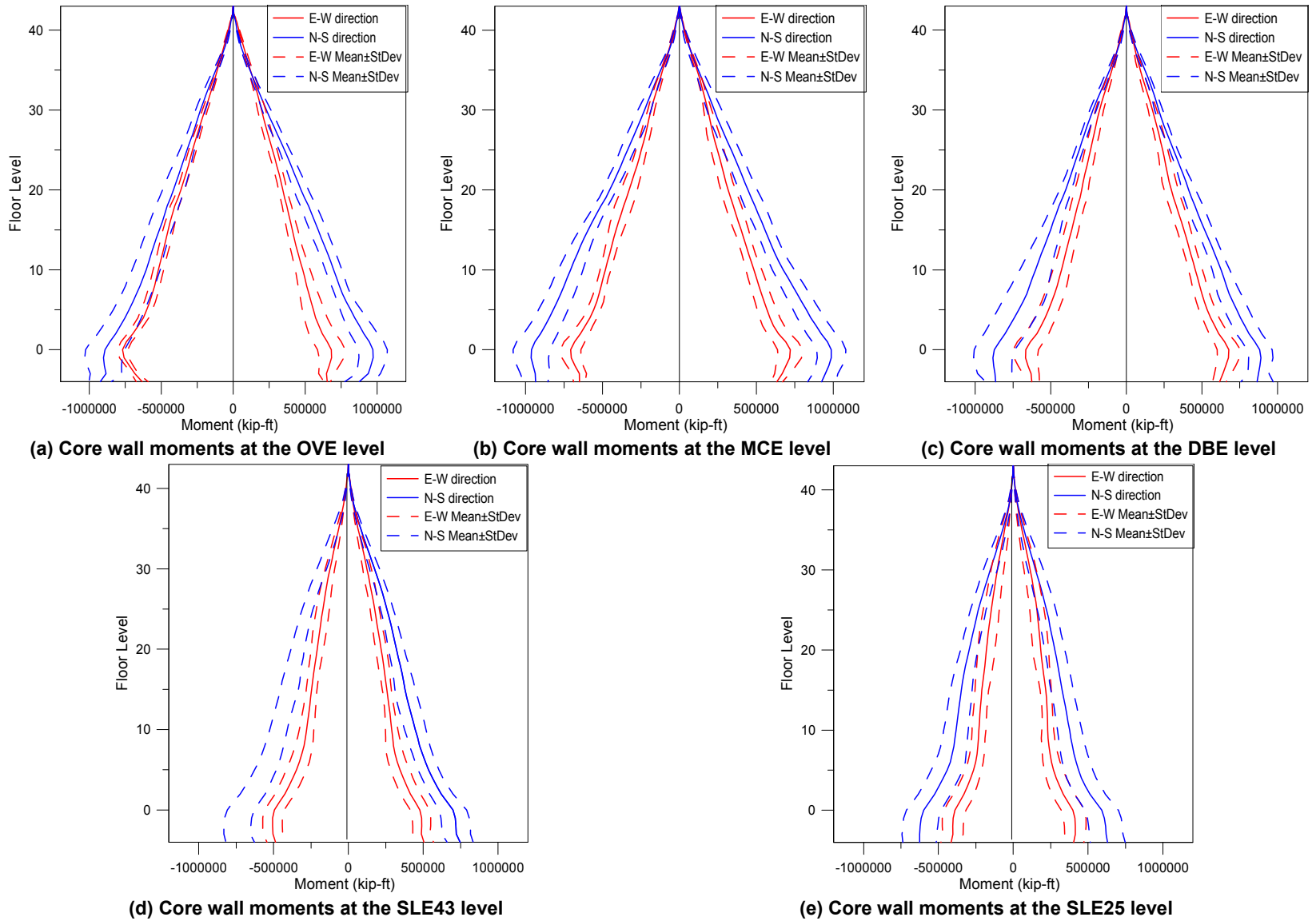

Figure 4.30 Core wall moments under various hazard level.

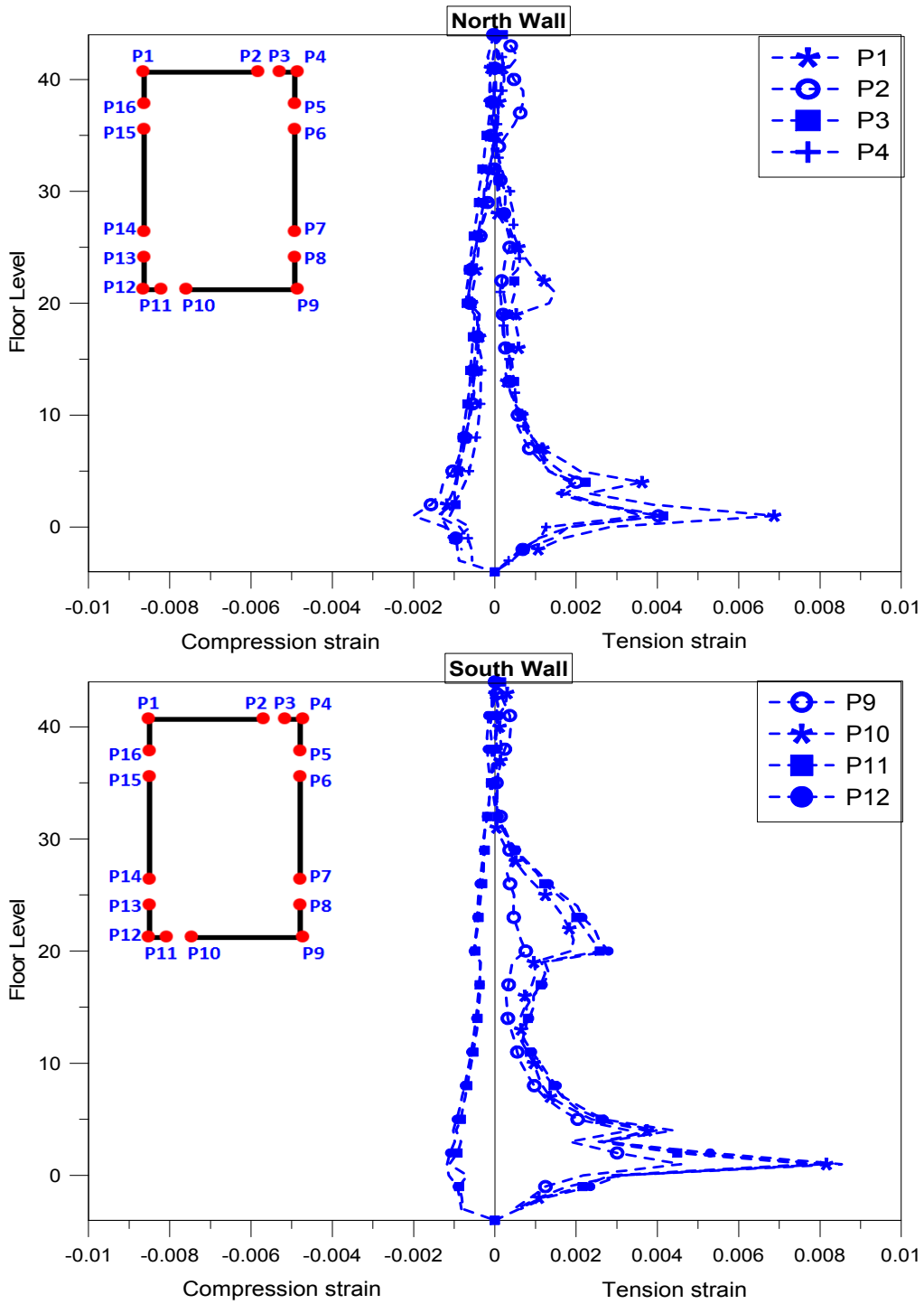

Figure 4.31 North and South wall strains at the OVE level.

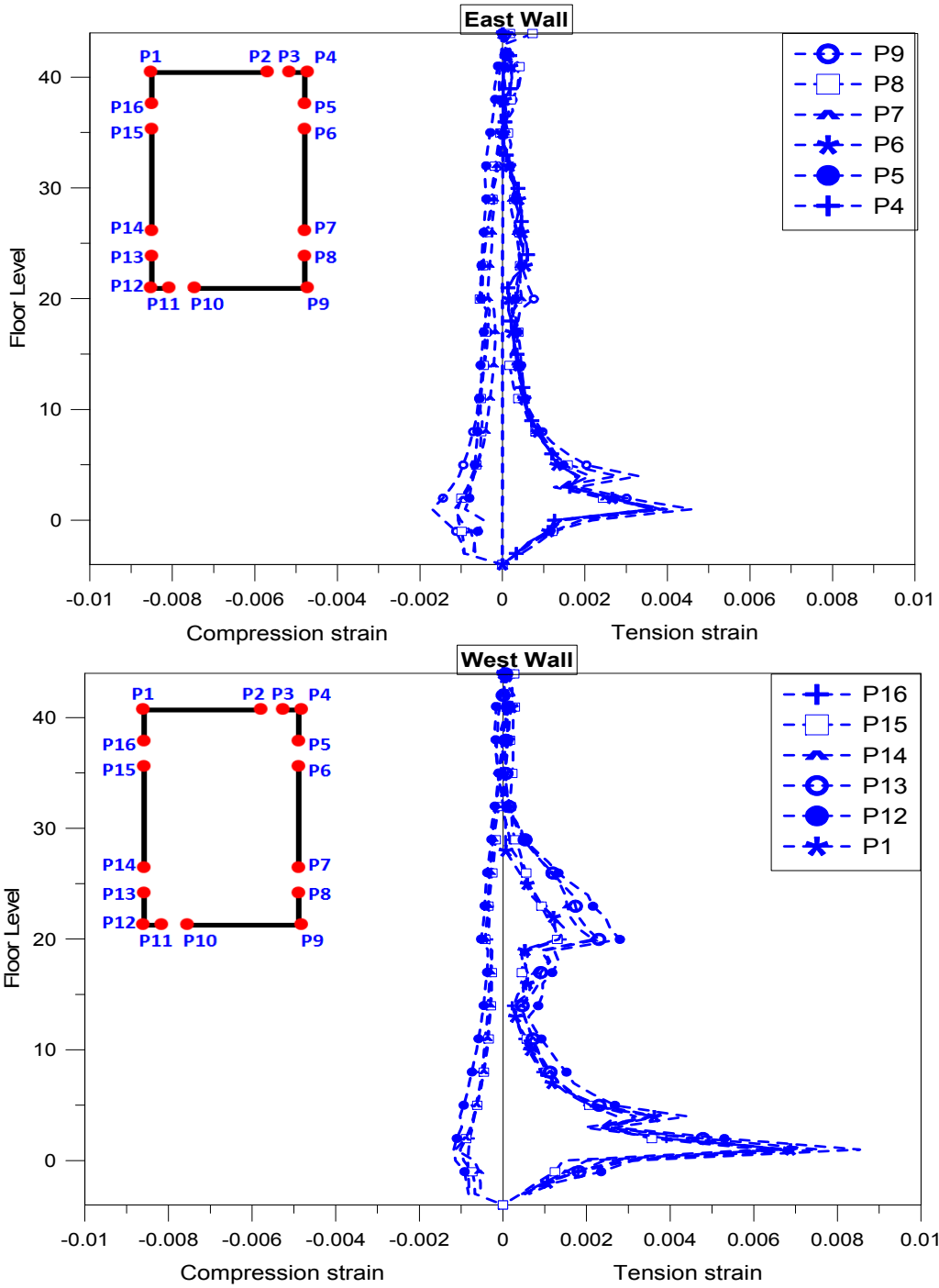

Figure 4.32 East and West wall strains at the OVE level.

Coupling Beam Rotations

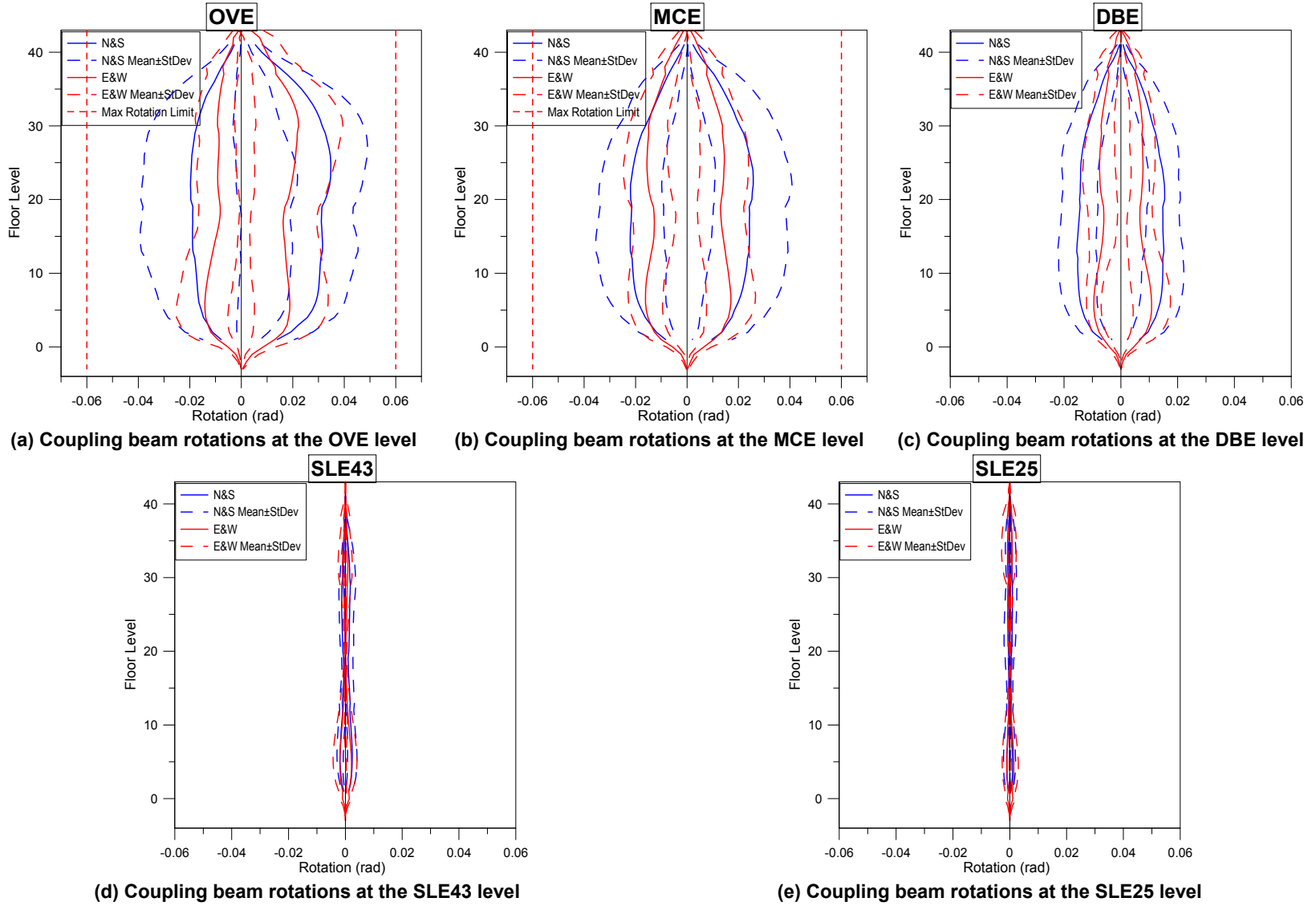

Figure 4.33 Coupling beam rotations under various hazard levels.

4.4.3 Frame Behavior

4.4.1.3 Building 2A

To evaluate the SMF response, peak values of beam and column rotations were obtained over the building height for the OVE-level ground motions as they are the best indicators for the frame response (Figures 4.34 and 4.37). Peak beam rotations were about 0.025 radians with a standard deviation of 0.005 radians, considerably less than the rotation limits established by ASCE 41-06.

To assess the potential for column axial failures, axial forces were normalized by $A_g f'_c$, where A_g is the column cross sectional area and f'_c the expected concrete strength; column nonlinear rotation demands were evaluated (Figures 4.35 and 4.37). Interior columns (represented with dashed lines in Figure 4.35) experienced much smaller axial demands than the corner columns, which are shown as solid lines. Given that the axial stresses were significantly higher in South-West and North-East columns, these columns were examined in more detail to determine whether column axial failure occurred. For that purpose, an axial load-moment interaction diagram was created for the most critical regions (the ground and fifteenth levels) and plotted along with the axial force-moment demand coupled under various OVE-level ground motions (Figure 4.36). The columns yielded when the demand reached the surface of the P - M interaction diagram. The magnitude of the column nonlinear rotation was examined to assess the potential for axial failure. Results plotted in Figure 4.37 indicate that nonlinear rotations were very low; therefore, axial failure was not anticipated.

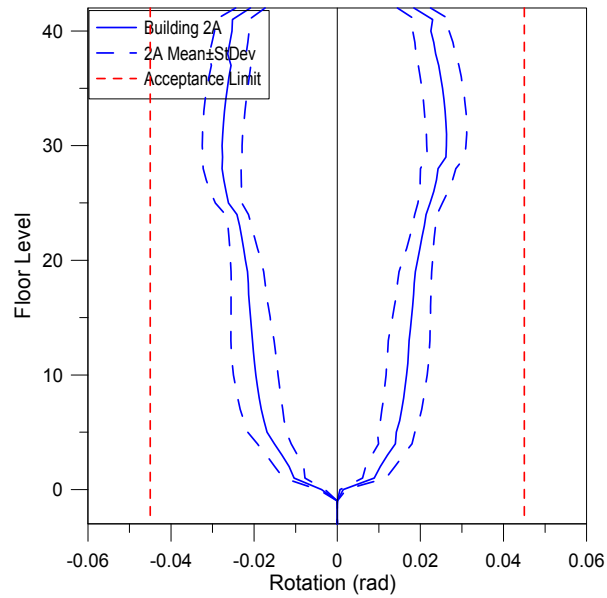

Figure 4.34 Frame beam rotations at the OVE level.

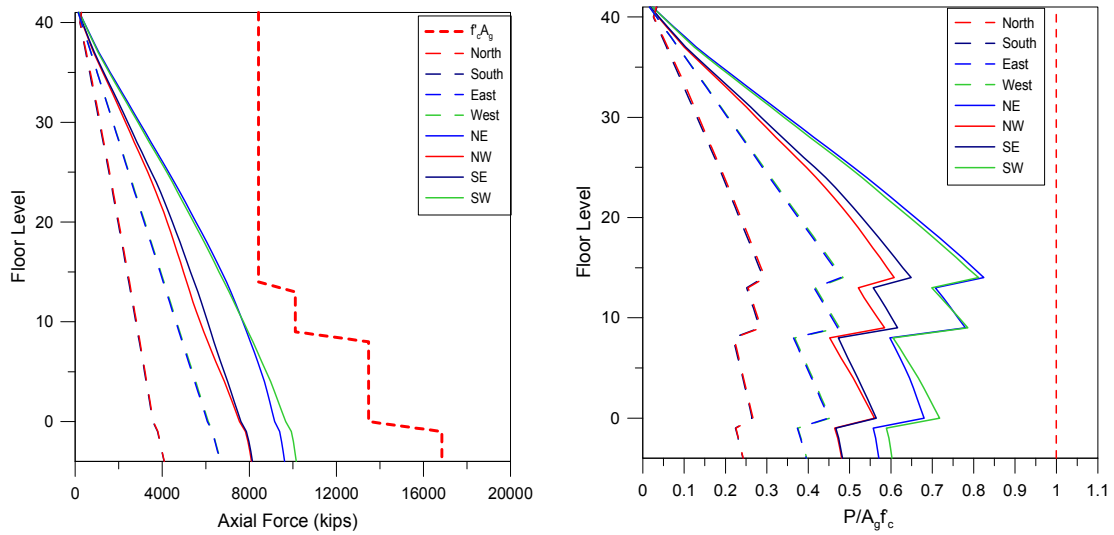

Figure 4.35 Absolute and normalized column axial forces at the OVE level.

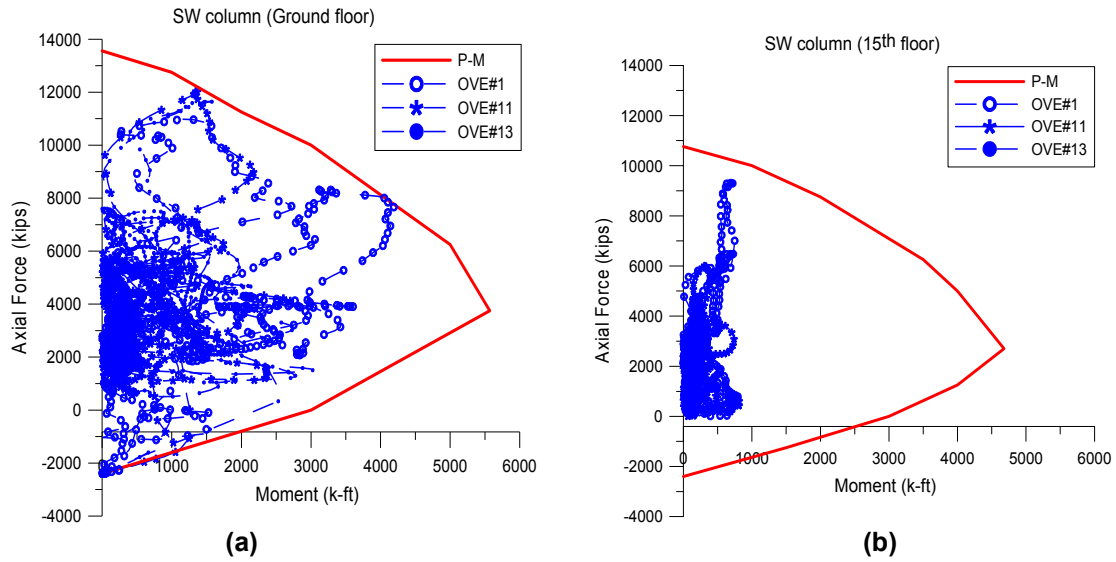

Figure 4.36 *P-M* interaction diagram for South-West column at (a) ground floor; and (b) fifteenth floor.

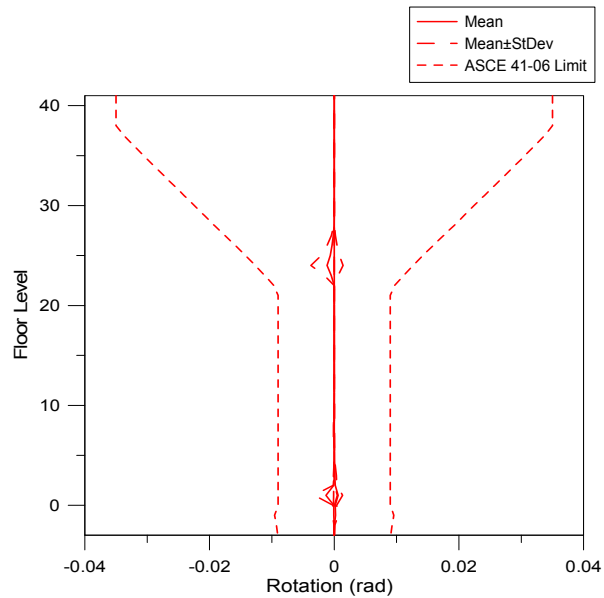

Figure 4.37 Frame column rotations at the OVE level.

4.4.3.2 Building 2B

The SMF beams and columns of Building 2B were also examined in terms of rotations and axial forces (Figures 4.38-4.40). Similar behaviors were observed; however, in Building 2B, beam rotations are slightly larger (about 10%), and axial forces are about one-half the values as those

noted for Building 2A. Given these relatively small values, axial failure was not anticipated in Building 2B.

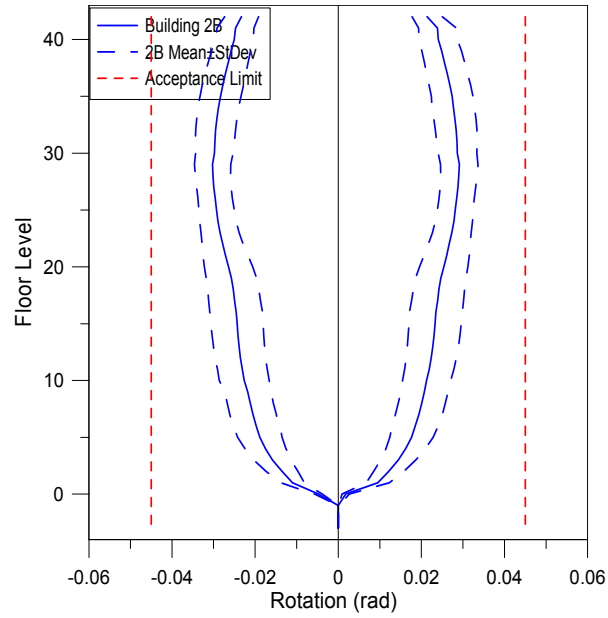

Figure 4.38 Frame beam rotations at the OVE level.

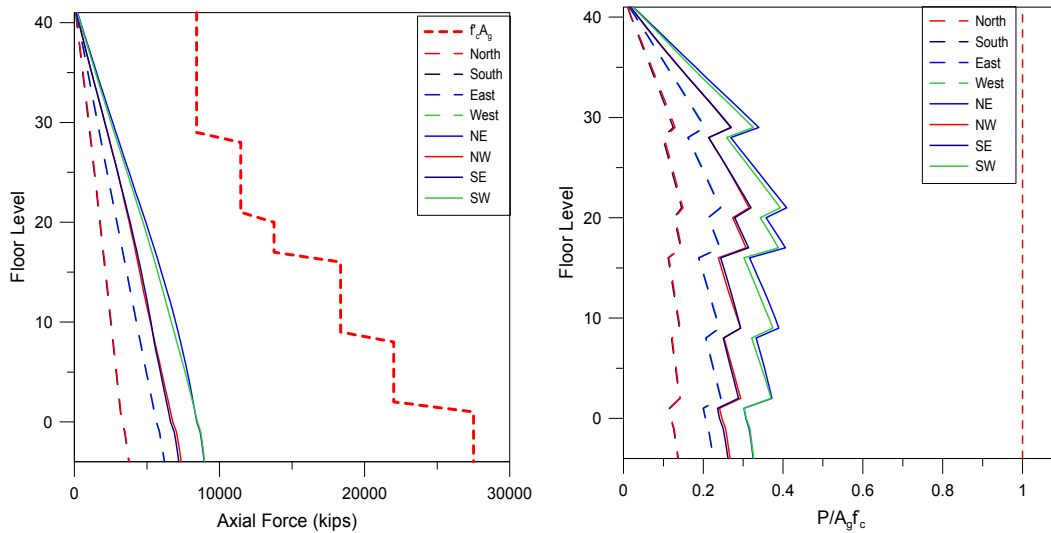

Figure 4.39 Absolute and normalized axial forces at the OVE level.

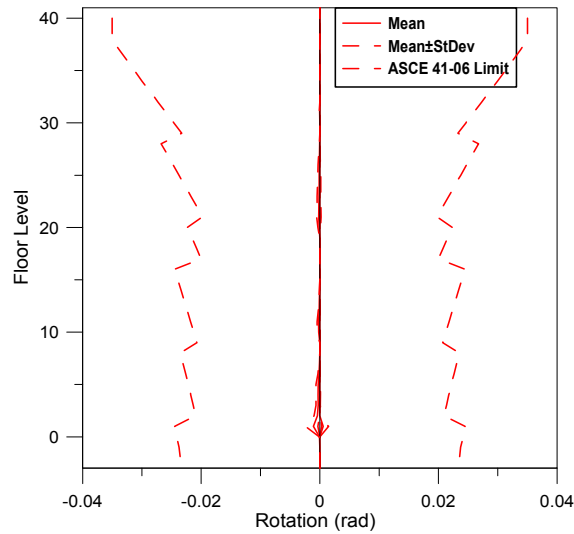

Figure 4.40 Frame column rotations at the OVE level.

4.4.3.3 Frame Contribution in the Dual System

The behavior of the SMF within the dual system was examined by investigating various response quantities. The relative contributions of the core wall and the SMF to story shear over the building height are shown in Figure 4.41. The shear force resisted by the core wall and the SMF was essentially linear and constant over the building height, respectively. For both buildings, the SMF resisted a significant portion of the story shear: about one-third at the ground level and one-half in upper stories. The thicker core wall in Building 2B resisted slightly more story shear than the wall in Building 2A.

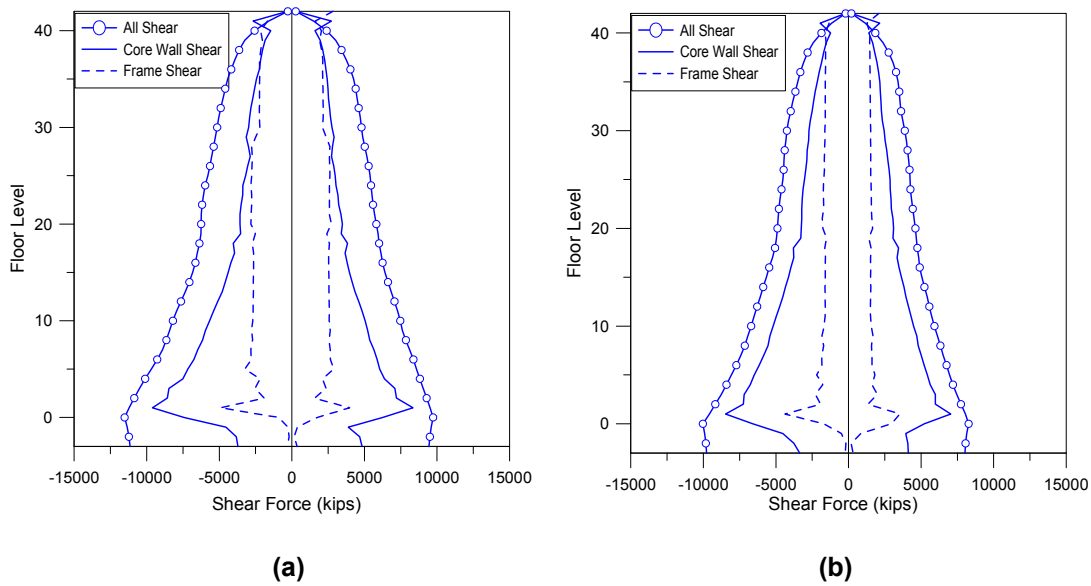

Figure 4.41 Distribution of shear forces in the system at the OVE level: (a) Building 2A; and (b) Building 2B.

4.4.4 Comparison of Building 2A and Building 2B

To enable direct comparisons between the two buildings, critical EDPs (interstory drifts, core wall shear stresses, core wall strain values, coupling beam rotations, frame beam rotations and normalized column axial forces) compared in Figures 4.42-4.47 for two hazard levels (SLE and OVE). Because the dispersion in the response quantities is about the same for Building 2A and 2B, only mean values were considered.

Based on this comparison, for both hazard levels the interstory drifts (Figure 4.42), core wall shear stresses (Figure 4.43) and axial compressive strains at the grade level (Figure 4.44) were slightly higher in Building 2A than in Building 2B. As previously noted, coupling beam rotations (Figure 4.45) and frame beam rotations (Figure 4.46) were greater for Building 2B, indicating more energy dissipation. However, in both buildings, these response quantities are typically well below limiting values (acceptance criteria). Normalized column axial forces in Building 2A are about twice the values in Building 2B (Figure 4.47).

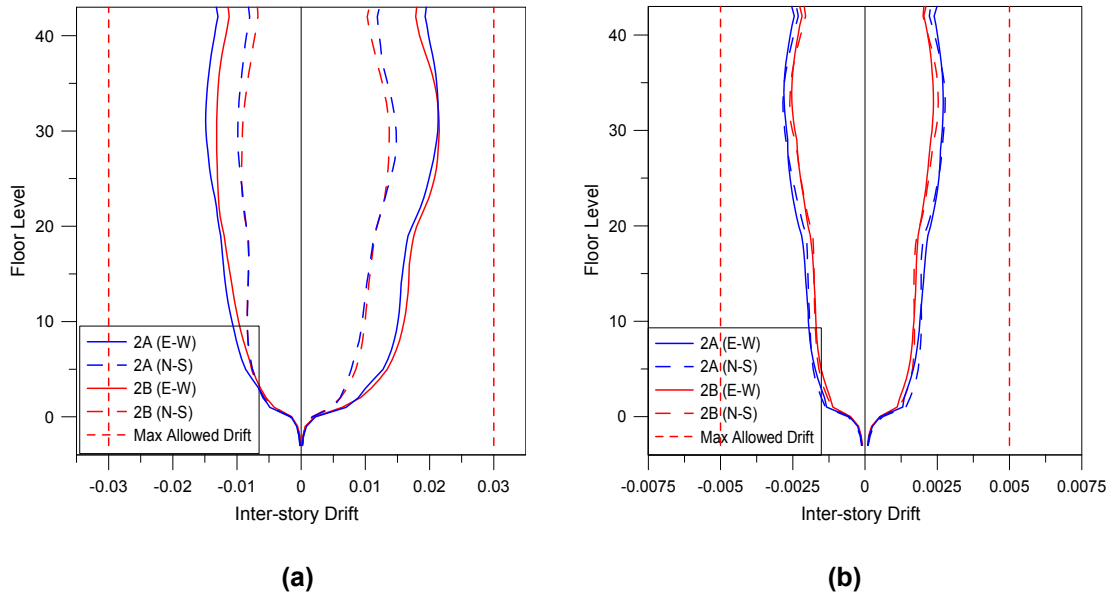

Figure 4.42 Comparison of interstory drifts (a) at the OVE level; and (b) at the SLE25 level.

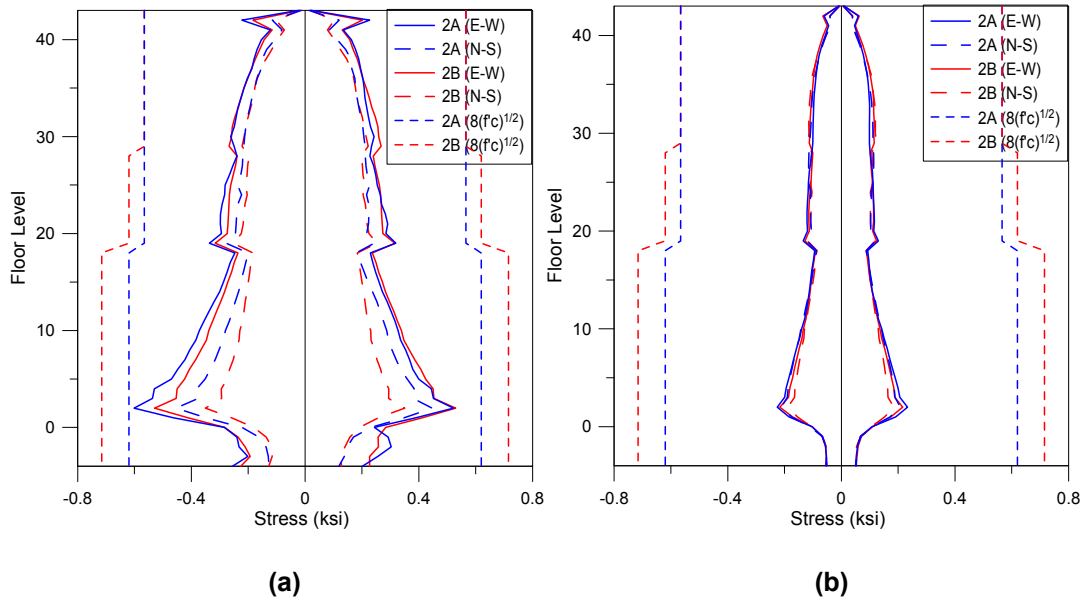

Figure 4.43 Comparison of core shear stresses: (a) at the OVE level; and (b) at the SLE25 level.

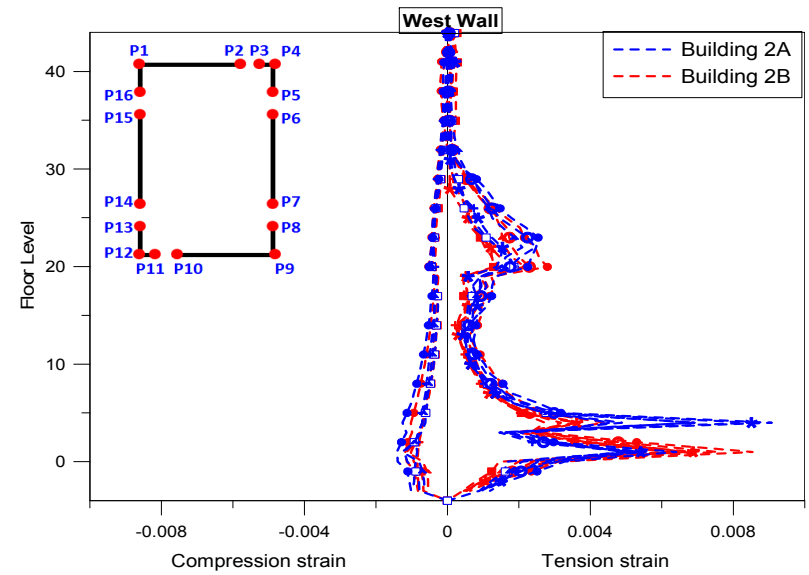
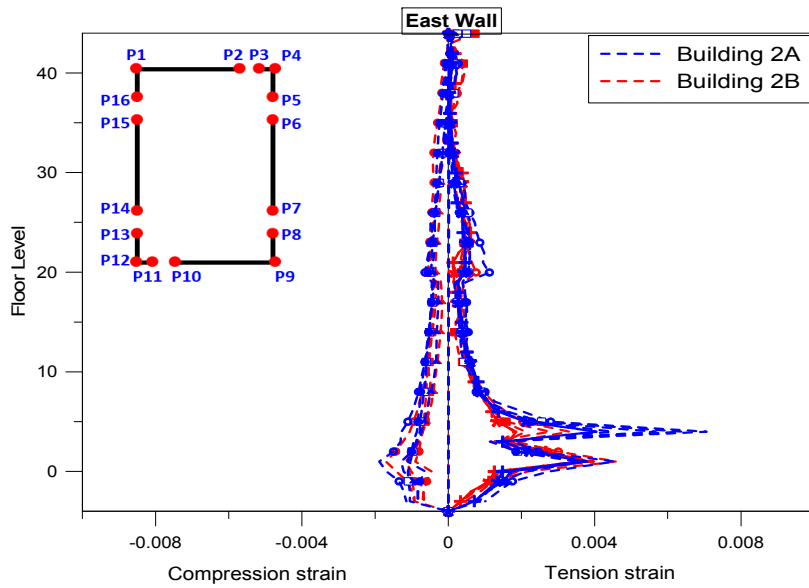
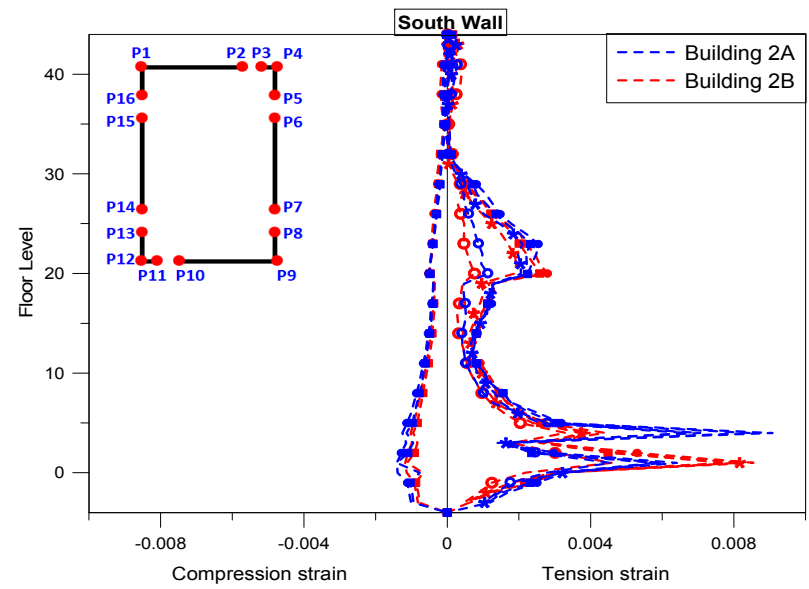
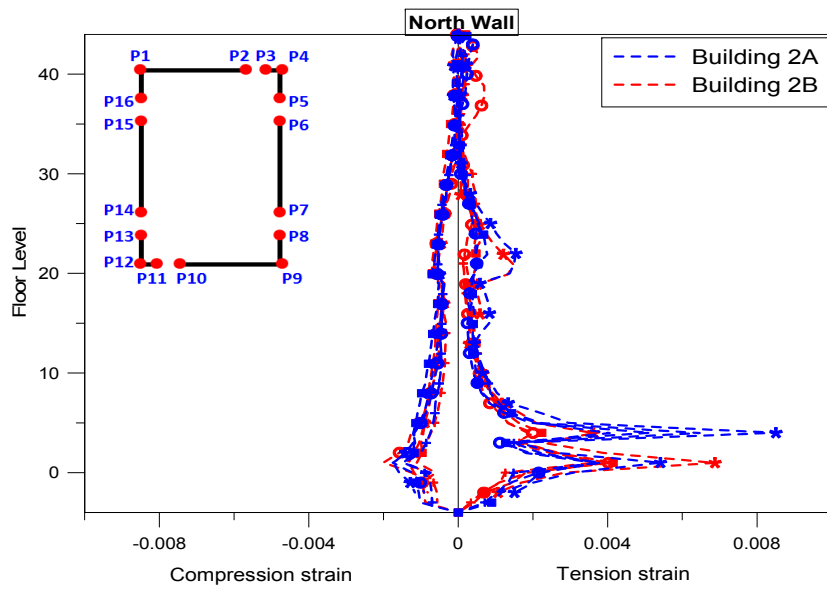

Figure 4.44 Comparison of core wall strains at the OVE level.

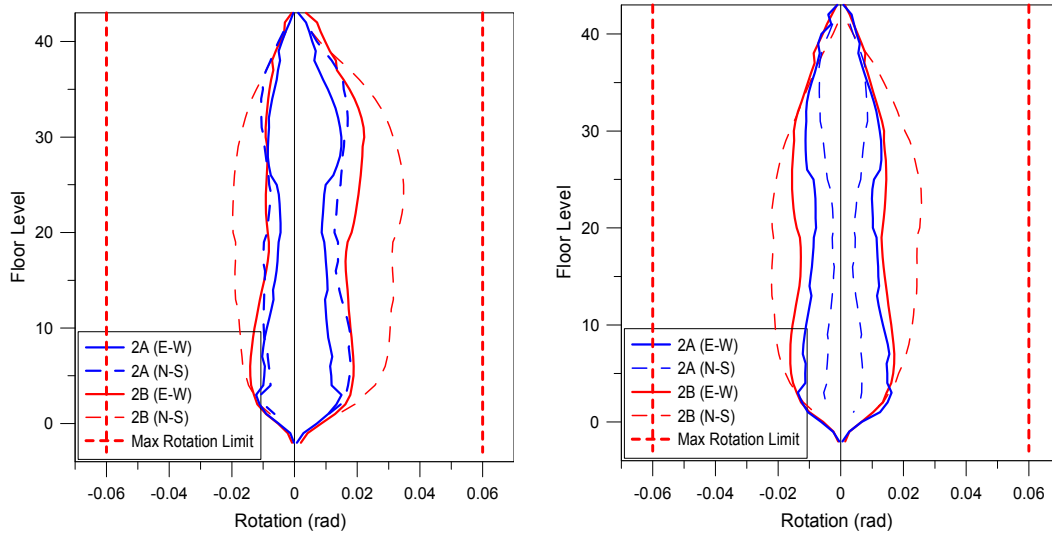

Figure 4.45 Comparison of coupling beam rotations (a) at the OVE level; and (b) at the MCE level.

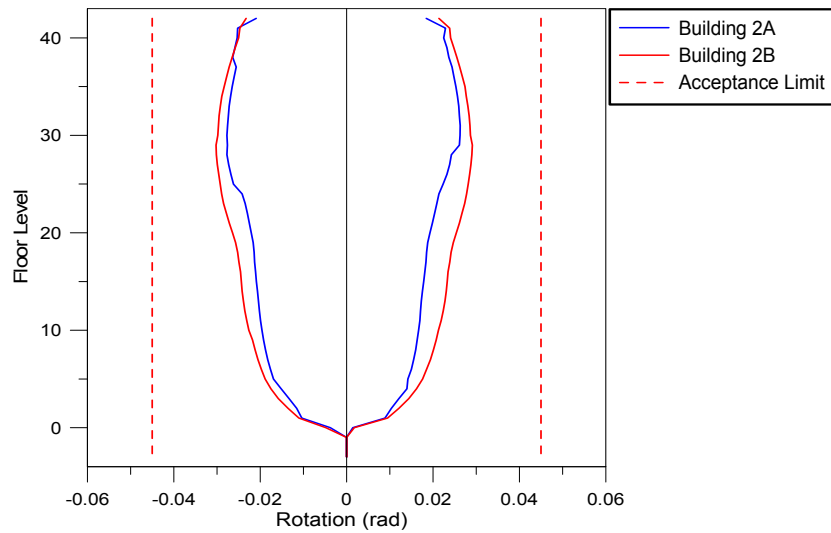

Figure 4.46 Comparison of frame beam rotations at the OVE level.

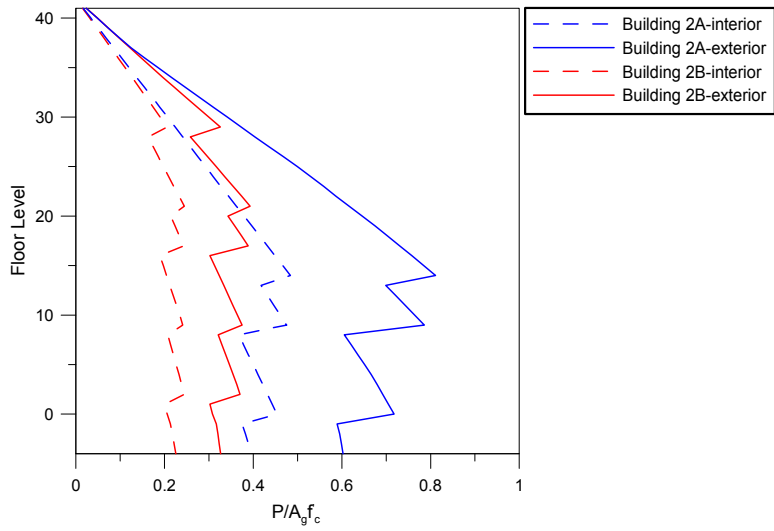

Figure 4.47 Comparison of normalized column axial forces at the OVE level.

5 Design and Performance of Building 3: Buckling-Restrained Braced Frame Structural System

5.1 INTRODUCTION

The Steel Buckling-restrained Braced Frame (BRBF) was used as the third structural system alternative in the TBI case studies. Three designs were carried out: Code-based design, performance-based design, and performance-based design plus. The design, modeling, and earthquake simulation results are presented next.

5.2 DESIGN OF BUILDING 3 STRUCTURAL SYSTEM

The design of BRBF structural systems for the TBI structures was prepared by Simpson Gumpertz & Heger, Inc. (SGH). Three design alternatives were developed: a code-based design (denoted as Building 3A), a performance-based design (denoted as Building 3B), and a performance-based design plus (denoted as Building 3C). Building 3A was designed according to the 2006 IBC, without consideration of the maximum height limit, Building 3B was designed according to the design criteria published by the Los Angeles Tall Building Design Council [LATBSDC 2008], and Building 3C was designed according to a preliminary version of the TBI Guidelines [Bozorgnia et al. 2009]. In the design process, wind and seismic loads were considered, and each structural element was designed for the most severe requirements [Dutta and Hamburger 2010].

Axonometric views of the three structures are shown in Figure 5.1. The building axes, defined in the figure as East-West (E-W) and North-South (N-S), are referenced throughout this chapter. The structural framing of the three buildings may be idealized as two systems, the lateral load resisting system (that transmits lateral loads to the foundation while concurrently meeting

any demand imposed by gravity loads) and the gravity framing system (that transmits gravity loads to the foundation and has comparatively little lateral strength resistance). This section will focus on the lateral load resisting system, which utilizes buckling-restrained braces (BRB), specially manufactured braces that are designed to yield both in compression and tension without buckling. Note that the gravity framing in the three buildings consisted of steel columns and beams with composite metal decking and lightweight concrete fill. Additional details about the gravity framing can be found in [Dutta and Hamburger 2009b].

The basic envelope of all three designs is the same: a 40-story building with a 227 ft × 220 ft footprint. Typical floor plans are shown in Figures 5.2-5.4. Typical BRB bays are shown in Figure 5.5; note the variations of the connections—from 300 to 1200 kips—between members depending on the strength of the specified BRB. Figure 5.6 shows a typical column cross section; columns range from 18 in. to 57 in. square. Beams utilized in the BRB bays were steel W sections. Both the columns and the beams in the BRB bays were designed to remain linear when yielding of the braces occurs under large lateral displacements. Columns in the lateral load carrying system were concrete filled steel box columns, fabricated from steel plates (1.5 in. to 3 in.), utilizing continuous welds and filled with high strength concrete ($f'_c=10,000$ psi).

The designs varied due to the difference in the seismic design requirements [Moehle et al. 2009]. For Building 3A, linear response spectrum analysis was used to calculate seismic forces and displacements per ASCE 7-05, using forces scaled to 85% of the base shear obtained from the equivalent lateral force procedure with $SDS = 1.145$, $SD1 = 0.52$, and $R = 7$. For Building 3B, where the design criteria in the LATBSDC criteria is less stringent compared to IBC 2006, the number and size of BRBFs were reduced. The LATBSDC criteria required that for frequent events (those with a 25-year return period) the building should remain at the service level at which building components remain elastic, with only minor yielding in BRBF components and a drift limit of 0.5%. In extreme events (at the MCE level) the building should withstand shaking without collapse, with a maximum drift ratio limit of 3%. For Building 3C, the serviceability earthquake—that event with the 43-year return period—requires that the demand-to-capacity ratio does not exceed 1.5. The increased demands led the design team to introduce outriggers in the structural system.

Considering the structural frames along the longitudinal axis (running E-W) of all three designs, the bracing configurations were identical, with three central bays bracing extending the height of the structure. The only difference between these frames is in the member size and

strength. Considering the transverse axis (running N-S) of all three designs, the bracing configurations varied significantly along grid lines grid lines 2 and 7. A comparison of the three bracing configurations is shown in Figure 5.7. This variation along grid lines 2 and 7 is the most significant difference between the three designs and can be summarized as follows:

- The code design (Building 3A) used three bays of bracing for the first ten stories and a single central bay above.
- The performance-based design (Building 3B) used a single central bay of bracing for the height of the structure.
- The performance-based design plus (Building 3C) used a single central bay of bracing augmented with outrigger trusses spanning three bays at the twentieth, thirtieth, and fortieth stories.

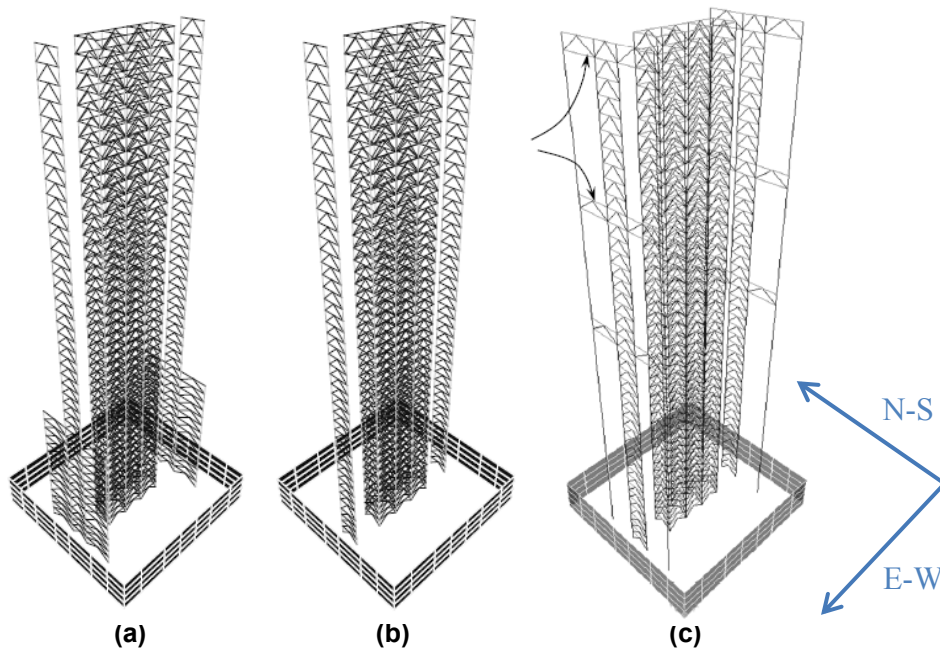

Figure 5.1 Three-dimensional views of the structures used in the study: (a) the code based design, Building 3A; (b) the performance based design, Building 3B; and (c) the performance based plus design, Building 3C. Image modified from Dutta and Hamburger [2009a].

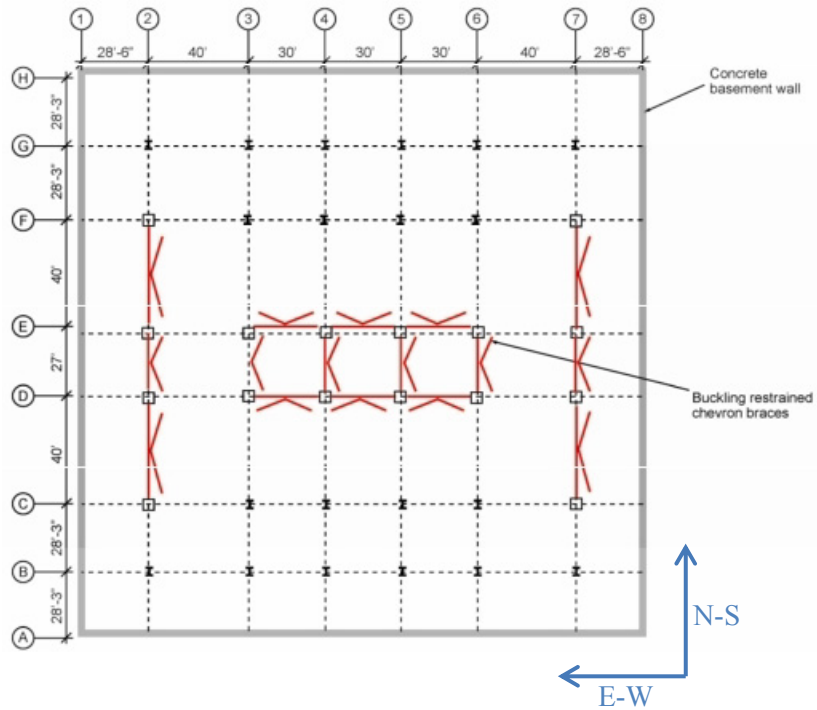

Figure 5.2 Plan at ground floor and basement (subterranean) levels for Building 3A. Buildings 3B and 3C are similar. Box columns are shown as squares and the gravity columns are shown as W sections (I symbol). BRB bays are shown in red. The grey walls at the perimeter indicate the concrete basement walls. For the four subterranean levels, the walls are specified as 18 in. thick for the two highest and 24 in. thick for the two deepest. Image courtesy of Dutta and Hamburger [2010].

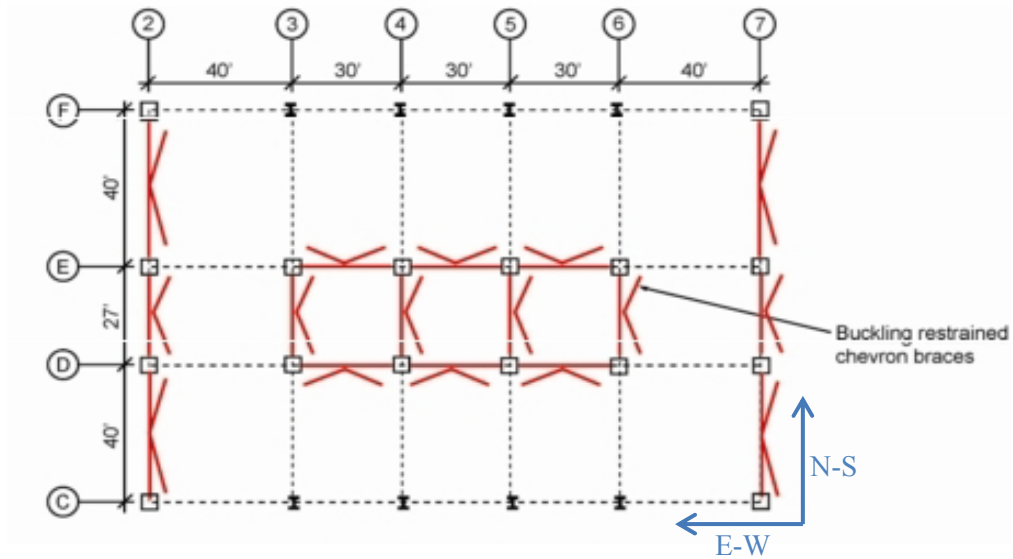

Figure 5.3 Plan of superstructure with three braced bays at grid lines 2 and 7. For Building 3A the plan corresponds to the first through tenth floors. For Building 3B the plan does not apply at all. For Building 3C the plan corresponds to the twentieth, thirtieth, and fortieth floors, which utilize outriggers. Box columns are shown as squares and the gravity columns are shown as W sections (I shaped). BRB bays are shown in red. Image courtesy of Dutta and Hamburger [2010].

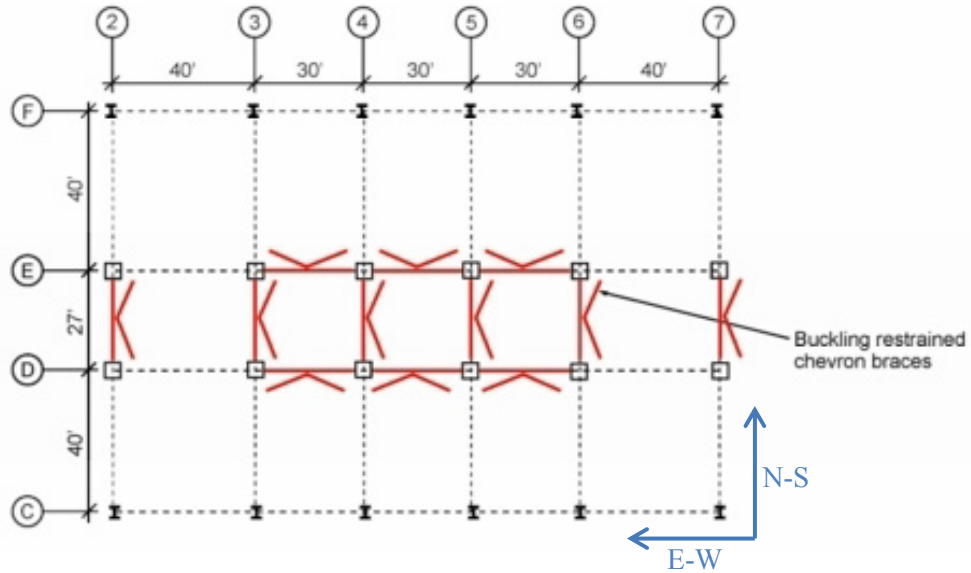
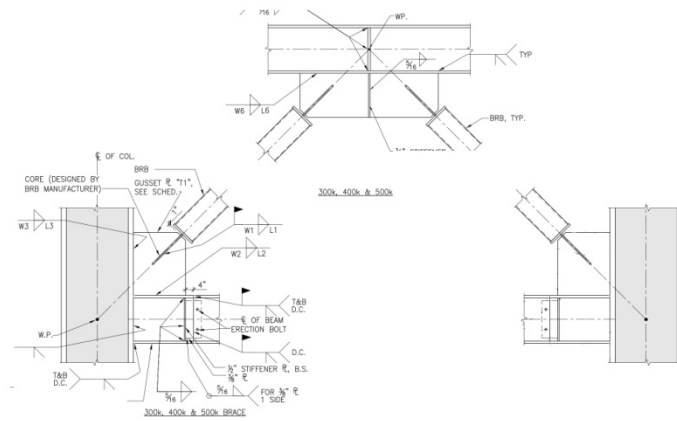
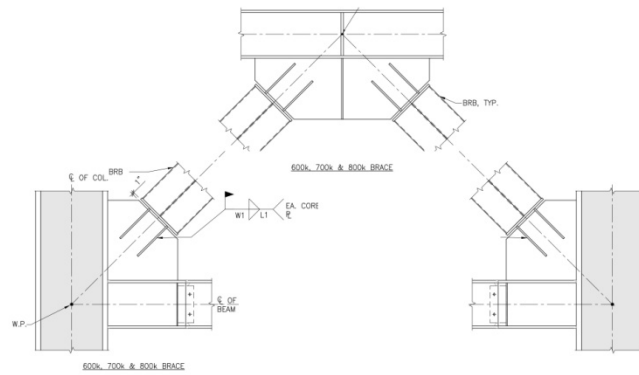

Figure 5.4 Plan of superstructure with single braced bay at grid lines 2 and 7. For Building 3A the plan corresponds to the eleventh through fortieth floors. For Building 3B the plan corresponds to the all of the floors (first through fortieth). For Building 3C the plan corresponds to all of the floors that do not include outriggers (hence the twentieth, thirtieth, and fortieth floors are excluded). Box columns are shown as squares and the gravity columns are shown as W sections (I shaped). BRB bays are shown in red. Image courtesy of Dutta and Hamburger [2010].



(a)



(b)

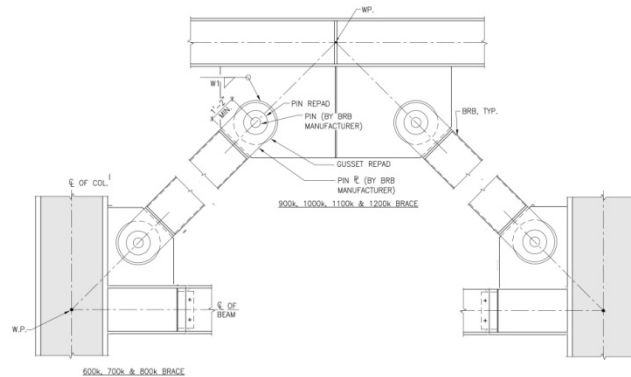

(c)

Figure 5.5 Details showing elevations of BRB to gusset connections for a typical bay: (a) as specified for 301-500K strength BRB; (b) as specified for 501-800K strength BRB; and (c) as specified for 801-1200K strength BRB. Image modified from Dutta and Hamburger [2009b].

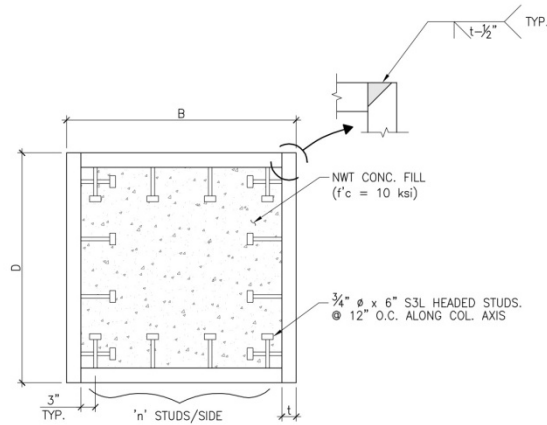

Figure 5.6 Cross section of typical concrete filled box columns. The columns range in size from 18 in. × 57 in. square. Concrete used in the columns has a design strength of $f'_c = 10,000$ psi. Image courtesy of Dutta and Hamburger [2009b].

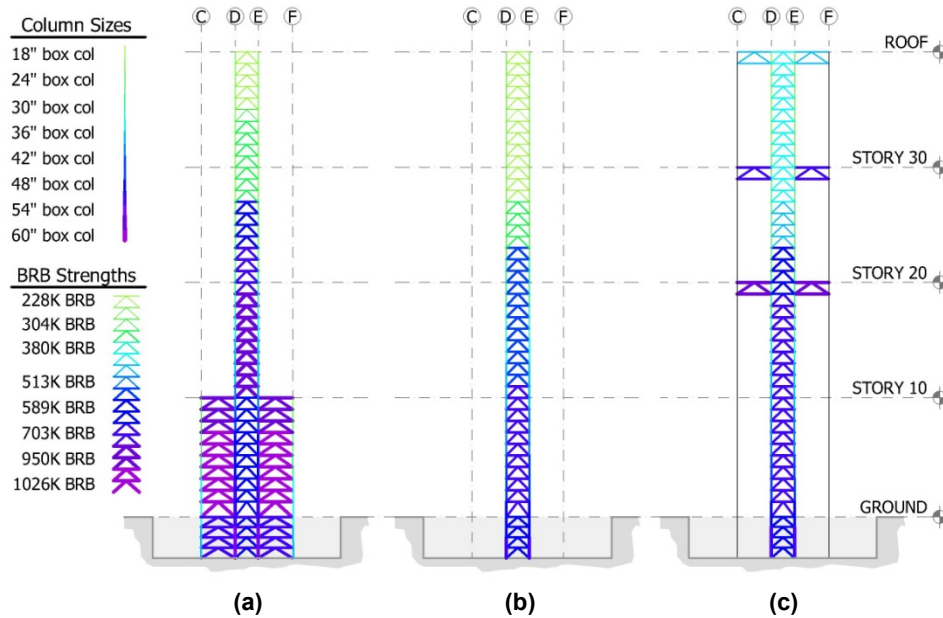

Figure 5.7 Elevation of lateral load resisting frame along grid lines 2 and 7 (frame parallel to N-S direction). BRB strengths in kips are color coded per key: (a) The code based design, Building 3A; (b) the performance based design, Building 3B; and (c.) the performance based plus design, Building 3C.

5.3 DEVELOPMENT OF THE STRUCTURAL ANALYSIS MODELS FOR BUILDING 3

For design and assessment purposes, the primary lateral force resisting elements of the three designs were modeled and analyzed in Perform-3D [CSI 2008]. Models that included the gravity framing were developed as well. Based on the relatively stiff nature of the BRBF, inclusion of the gravity framing did not significantly change the results for the maximum interstory drift ratios (maxIDR) or the PFAs. Therefore, only the models of the lateral load resisting system were used to generate the EDPs required for the loss assessment process.

There are two modeling strategies for the floor diaphragms in the model: one for the ground and subterranean levels and one for the floors above. For the ground and subterranean levels the diaphragms were modeled with elastic shell elements using 30% of the gross cross-section properties [Dutta and Hamburger 2010]. Further contributing to the stiffness in the subterranean levels are the perimeter shear walls. These were modeled with elastic wall elements with 50% of the gross stiffness and 40% of elastic shear modulus to account for cracked section properties [Dutta and Hamburger 2010]. For the floors above ground, a rigid diaphragm behavior was assumed, with nodes in each floor slaved for in-plane displacements and rotation; in these upper levels the rotational stiffness of the slab and gravity framing was ignored.

A typical BRB bay considering any of the structures is made up of concrete box columns, W section steel beams, gusset connections, and BRB members. The modeling strategy to account for all of these elements is shown in Figure 5.8. All of the elements were modeled with elastic elements except for the BRB core. Strength sections were employed at critical member locations of beams and columns to ensure elastic behavior. If at any point in an analysis the strength demand exceeded the capacity the analysis stops.

The details and assumptions used to model the beams and columns of a typical BRB bay were as follows:

- The concrete filled box columns were modeled with linear non-prismatic steel sections. The area, moment of inertia, and torsional properties of the member cross sections were adjusted to account for the additional stiffening due to the presence of the infill concrete. Strength checks were located at member ends to monitor the interaction of axial and moment loading (*PMM* interaction).
- Beams were modeled with linear, prismatic, standard steel sections. Their stiffness and strength were not adjusted to take into account the presence of the floor slab.

Each beam was assumed to span the center-line to center-line distance between the nodes and does not account for the column depth (such as with a rigid beam end zone). In addition, the beams are assumed to be pinned at their ends; therefore, the geometry of the beam-stub, additional bending resistance of the gusset plate, and the partially rigid behavior of the connection were not accounted for. Strength checks for moment capacity were employed at the center of the beam span.

The buckling-restrained braces were the only nonlinear elements employed in the model, using the built-in BRB component of Perform-3D, a compound bar-type element that resists axial force only and has no resistance to torsional or bending forces [CSI 2006]. The element may be thought of as two bars in series: a linear one to represent end zone behavior and a nonlinear one to represent behavior of the yielding portion of the brace. The following are details and assumptions used in the BRB end zone and brace modeling:

- 30% of the node-to-node length of the brace element was assigned as a non-yielding end zone. This linear bar represents the combined stiffness of the gusset, the brace connection, and the portion of the column that was not accounted for using center-line to center-line geometry. The strength or stability of the connections was not considered. In essence, it was assumed that they were well designed and would not fail, even under large cyclic displacements. The stiffness of the linear bar was assumed to be much stiffer than the BRB element and was essentially rigid.
- 70% of the node-to-node length of the brace element was assigned as the nonlinear BRB element. Figure 5.9 shows the backbone curve of BRBs in terms of force and displacement, and the values that were used to generate it. The analysis stops if the mean strain in any brace exceeds $20\Delta_y$, the theoretical ultimate strain limit. In addition, the mean strain in the cores of BRBs were monitored to check that it did not exceed a performance limit of 0.013 ($10\Delta_y$), the assumption employed by SGH's design team based on test results conducted at the University of Utah by Romero and Reaveley [Dutta and Hamburger 2010]. For simplicity, isotropic hardening and accumulated deformation capacities were ignored in the BRB model.

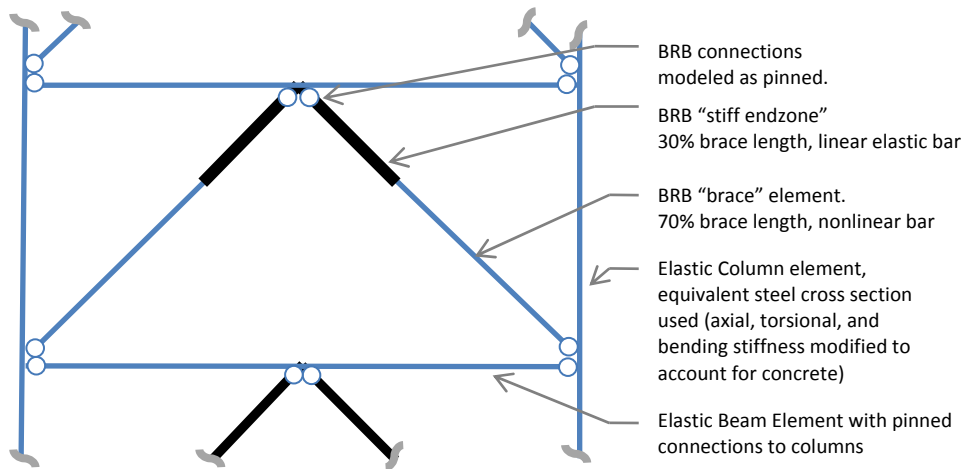

Figure 5.8 Modeling elements used in a typical BRB bay.

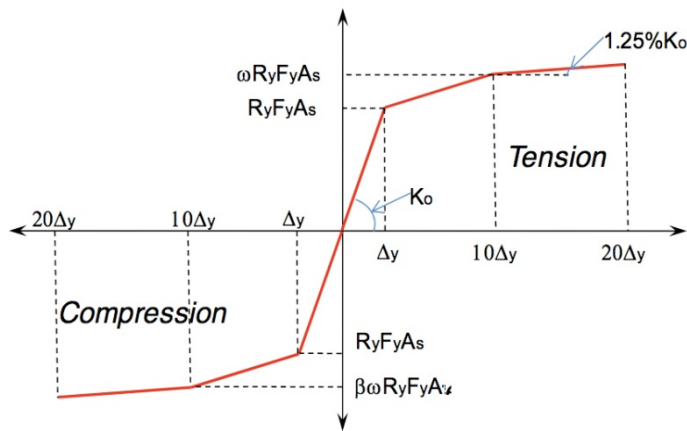

Figure 5.9 General backbone curve for the nonlinear BRB element. The vertical axis represents force and the horizontal axis represents deformation. A_s = area of yielding steel core, $K_o = A_s E / L$, $E = 29,000 \text{ ksi}$, $F_y = 38 \text{ ksi}$, $R_y = 1.1$, $\omega = 1.25$, $\beta = 1.1$, and $L = 70\%$ of the brace length (using center-line to center-line geometry). Image courtesy of Dutta and Hamburger [2010].

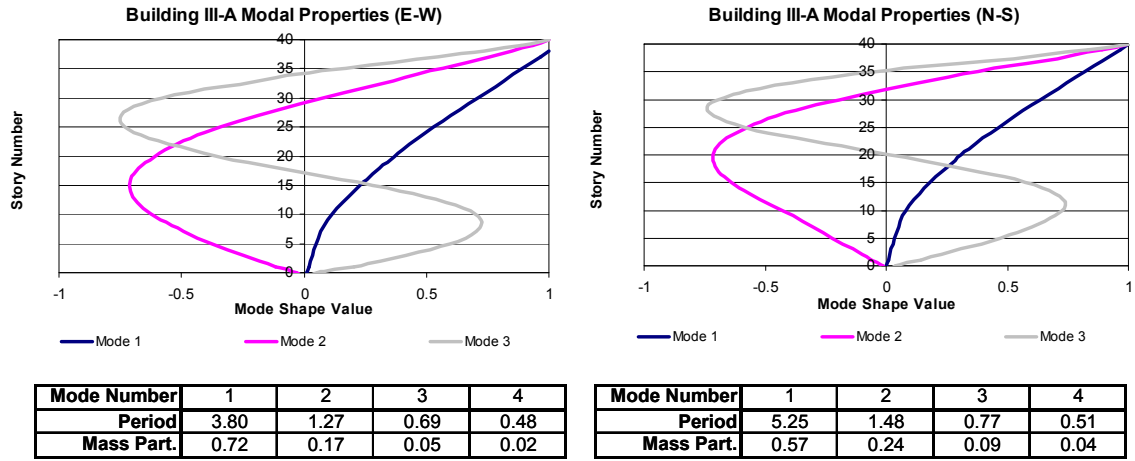

Figure 5.10 Modal properties for Building 3A (buckling-restrained braced frame designed based on conventional codes).

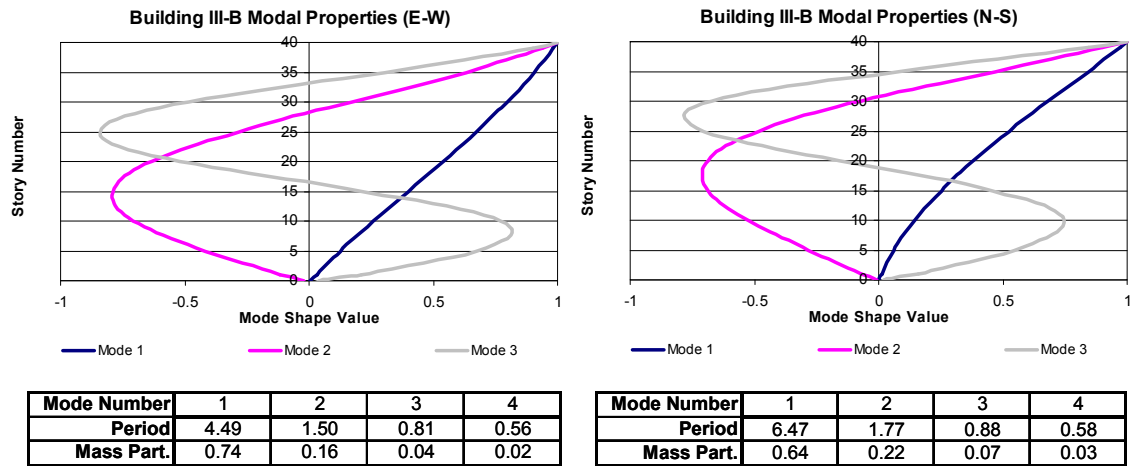

Figure 5.11 Modal properties for Building 3B (buckling-restrained braced frame designed based on conventional codes).

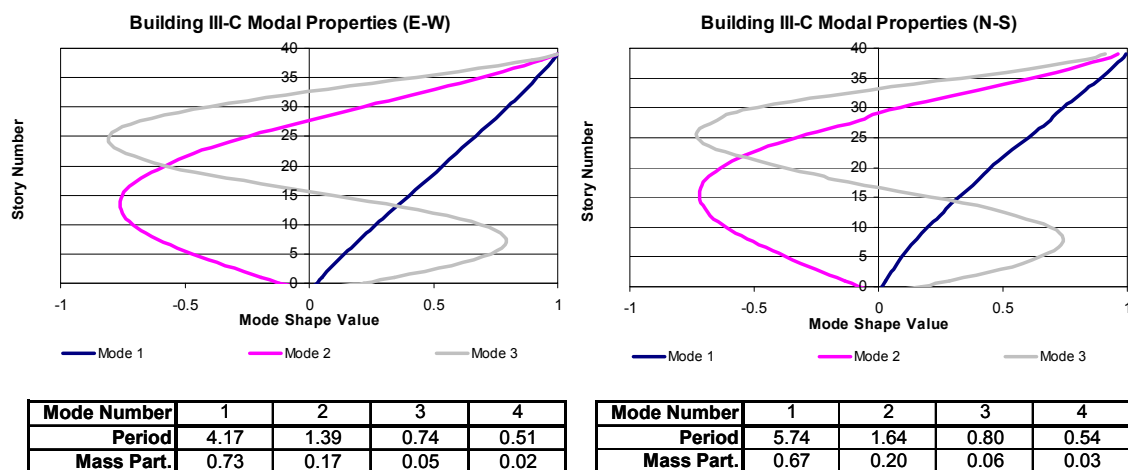

Figure 5.12 Modal properties for Building 3C (buckling-restrained braced frame designed based on conventional codes).

5.4 BUILDING 3 ANALYSIS RESULTS AND DISCUSSION

Figures 5.10-5.12 present the linear modal properties of the three building models. Building 3A was the stiffest, while Building 3B was the most flexible. Using the ground motions provided for the loss assessment process and the Perform-3D models of Buildings 3A, 3B, and 3C, nonlinear RHA was performed and the requisite EDPs were extracted. Figure 5.13 shows typical input motions (for the 25-year return period and 2045-year hazard levels, respectively) and the resulting acceleration and displacement responses at the roof for Building 3A.

The EDPs (reported at each story) for the steel structures are maximum interstory drift ratios (maxIDR), residual interstory drift ratios, and PFAs. Figures 5.14-5.16 show the maxIDR and resIDR results from the RHAs for Buildings 3A, 3B, and 3C, respectively. Figures 5.17-5.19 show the acceleration results from the RHAs for Buildings 3A, 3B, and 3C, respectively. In each figure, the plots are grouped by direction (E-W and N-S) and ground motion set as labeled in the column headings and row margins, respectively. The ground motion sets descend from the 4975-year hazard level (OVE) to the 25-year hazard level (SLE25). Individual earthquakes were plotted with light gray lines. The median response is shown with a heavy black line while the 16th and 84th percentiles are shown with a dashed yellow line.

Collapse is considered to occur if the lateral load resisting system fails. Given that the beams and columns remained linear during all of the analyses, it is assumed that failure of the BRBs themselves constitutes failure of the lateral load resisting system. The brace components in

the model have a maximum deformation capacity of $(20\Delta_y)$, the theoretical ultimate strain limit. If this capacity is exceeded during the time-history analysis the analysis stops. In addition, the braces are monitored with a strain limit of $10\Delta_y$. As there were no instances of component failure in the analyses, no collapses were reported for the three designs of Building 3.

Another metric for judging the safety of the structures is the maximum of maxIDR. For the discussion here, a performance limit of 0.03 IDR is considered as “safe against collapse.” Although structures that exceed this value of IDR do not necessarily collapse, at such values, extreme inelastic demands have been imposed on the structure. In the case of the OVE set of motions—those that have the longest return period—there are several ground motions that cause excursions of the maxIDR past 0.03. For the MCE ground motions, there is one instance for Building 3B where the 3% limit was exceeded. Otherwise, none of the other ground motions considered exceeded 0.03 IDR. Given the low likelihood of occurrence of the OVE motions, the structures performed well in terms of safety.

The results for maxIDR (Figures 5.14-5.16) were somewhat similar for all three buildings in the E-W direction but showed significant variation in the N-S direction, a result of the difference in brace configurations discussed earlier. A comparison of IDR results in N-S direction demonstrates:

- For Building 3A, the results are characterized by belts of lower drift demand in stories 1-10, which is a result of the additional bays of bracing deployed in these stories, providing them with additional strength and stiffness.
- For Building 3B, the results are characterized by a relatively even distribution of drift demand over the height of the structure as compared to Buildings 3A and 3C, which is a result of the design having more consistent strength and stiffness over the height over the structure
- For Building 3C, the results are characterized by belts of lower drift demand at the twentieth, thirtieth, and fortieth stories and bulges in between, which is a result of the outrigger truss deployed at these stories, providing them with additional strength and stiffness.

The results for resIDR (Figures 5.14-5.16) show that brace yielding tended to be well dispersed over a range of stories. To estimate the resIDR, ground motions were run for 10 sec longer than their duration to achieve a free vibration response. Then the resIDR was approximated by taking the mean of the last maximum and minimum amplitudes from the free

vibration response. The resIDR plots for the smaller return period sets (SLE25 and SLE43) are not shown as the structures remained essentially linear under these earthquakes. A single mechanism tended to form consistently in the lower stories (5-20) for all three structures in the E-W direction, while in the N-S direction two mechanisms were observed: one in stories 10-20 and one in stories 25-38. Otherwise, nonlinear behavior of the structures tended to be fairly complex, likely the result of significant contributions from higher modes.

The results for PFA (Figures 5.17-5.19) were also evidence of the nonlinearity in the structure: for the 475-year return period up to the 4975-year return period, the increase in return period did not yield a proportional increase in PFA because the nonlinear behavior limits the acceleration that the ground motion can impart on the structure. Accelerations were largest for Building 3A, while Buildings 3B and 3C exhibited somewhat similar acceleration behavior.

Focusing on mode shapes of the buildings shown in Figures 5.10-5.12 and deformation demands shown in Figures 5.14-5.16 demonstrate that the overall behavior of Buildings 3A and 3B were more similar to each other compared to the behavior of Building 3C, which was more unique. This is due to the difference between the general designs of structural systems for these buildings. The structural system in Building 3A and 3B are regular BRBFs, whereas the structural system of Building 3C is a BRBF with outriggers. Inclusion of outriggers reduced the drift demand in the twentieth, thirtieth, and fortieth stories in the N-S direction. Additional BRBF bays in the N-S direction of the lower stories of Building 3A significantly reduced the drift demand at these stories compared to other buildings. Building 3A (the code-based design) is a stiffer building compared to Buildings 3B and 3C. Therefore, the acceleration response of Building 3A was higher than Building 3B and 3C. In retrospect, the deformation demand in Building 3A was smallest compared to other two buildings. This difference between the two types of deformation demands (i.e., acceleration and drift) will be reflected in the estimated loss of the three buildings.

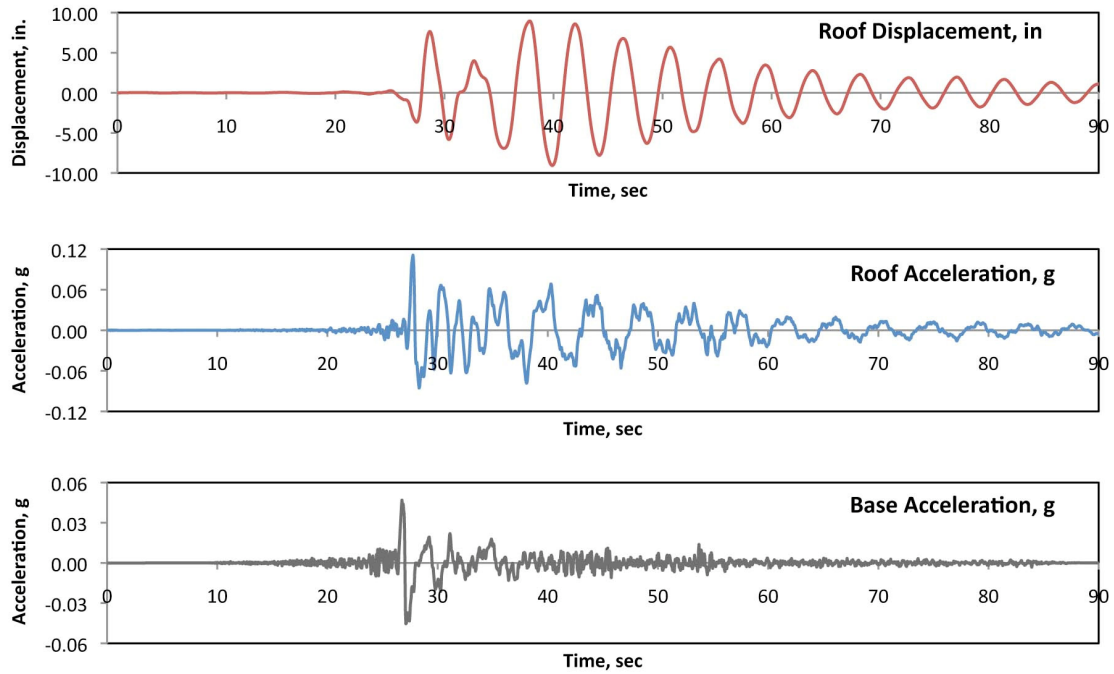

(a)

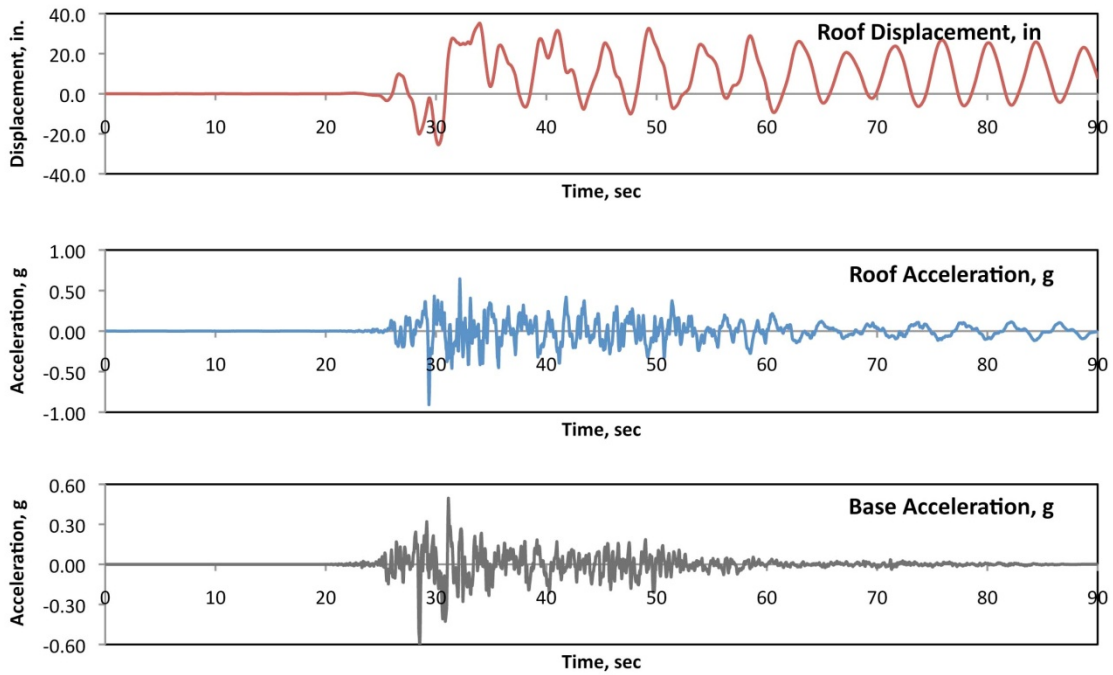

(b)

Figure 5.13 Typical input motion and roof response: (a) 25-year return period hazard; and (b) 2045-year return period hazard.

maximum IDR, building IIIa

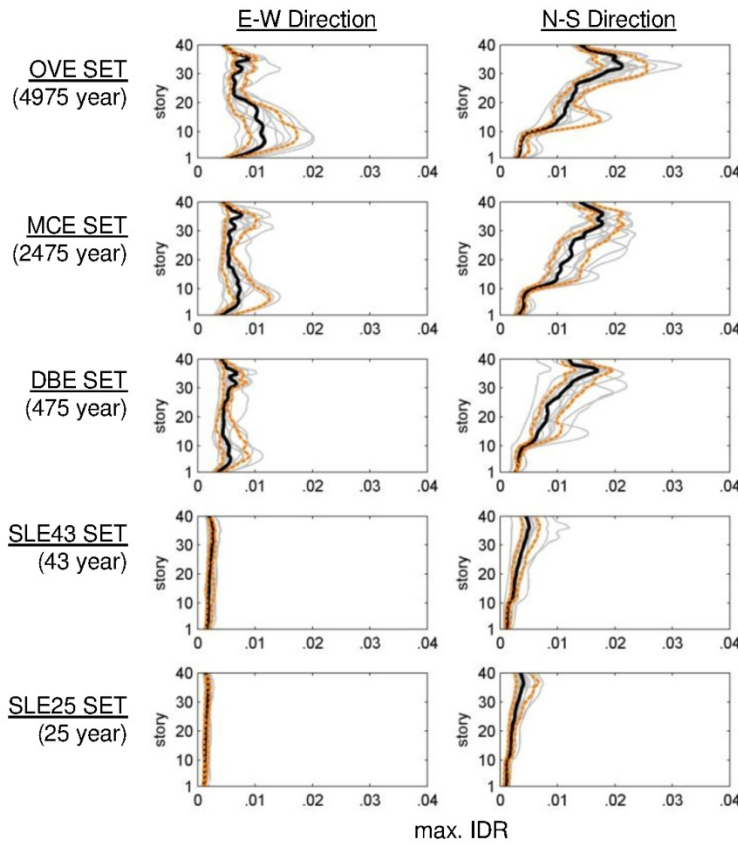

Key

- Individual earthquake response
- median of response
- 16th and 84th percentile

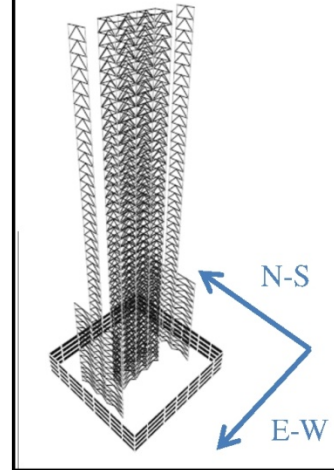

residual IDR, building IIIa

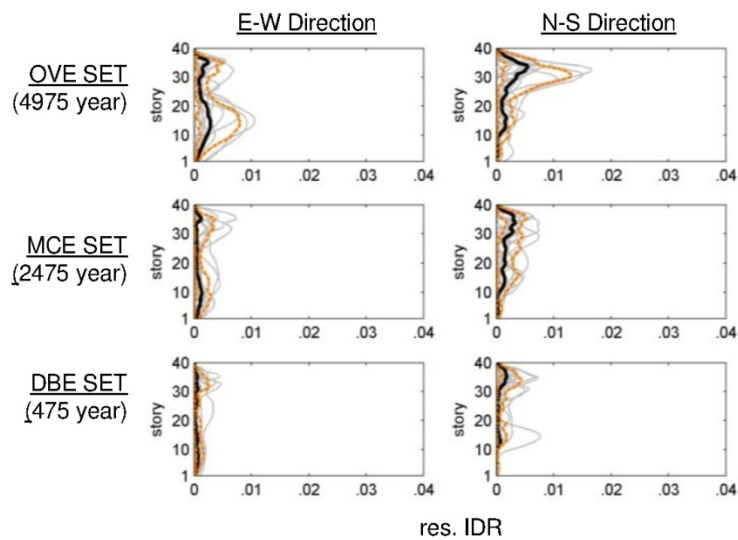
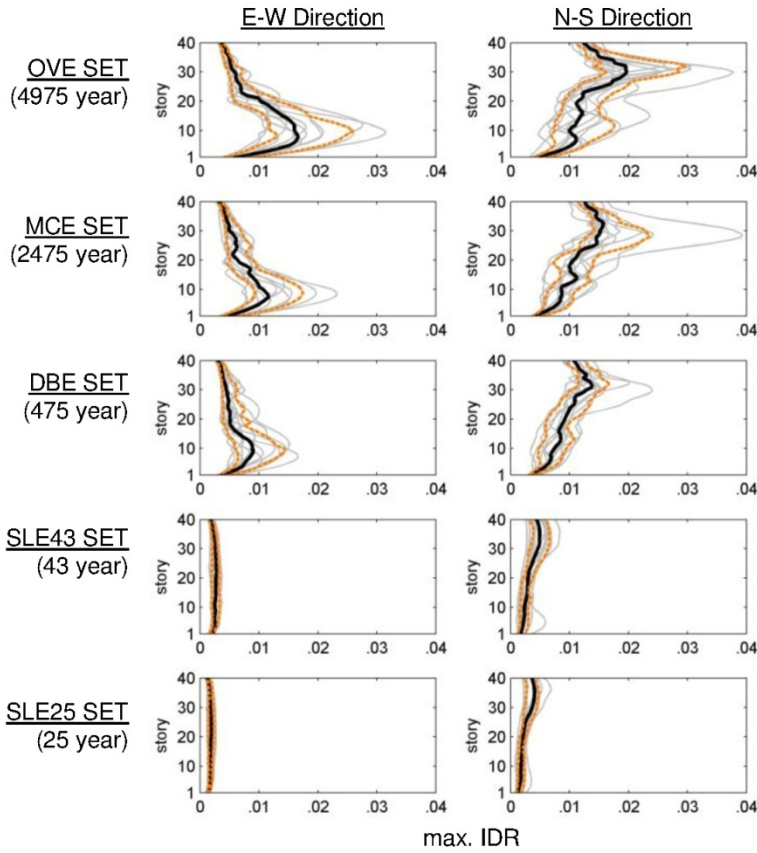
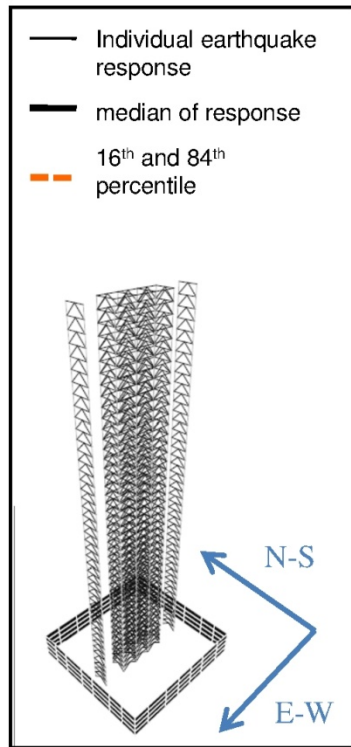

Figure 5.14 Results for Building 3A (code-based design) in terms of maxIDR and resIDR.

maximum IDR, building IIIb



Key



residual IDR, building IIIb

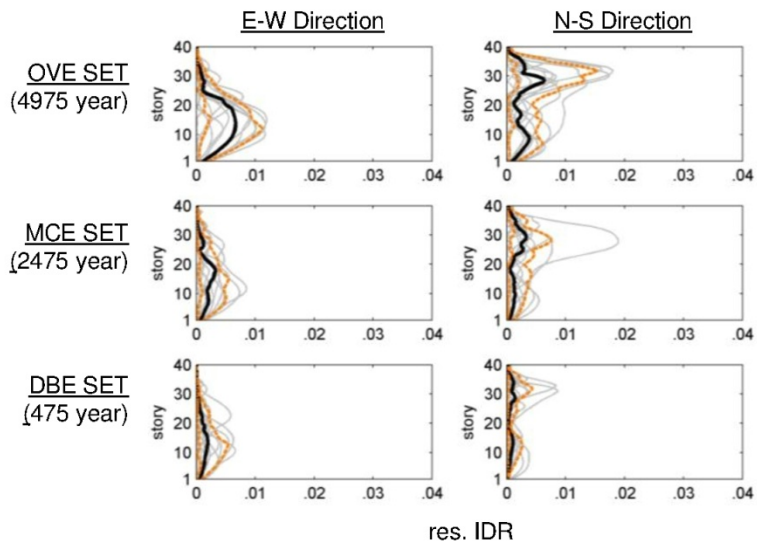
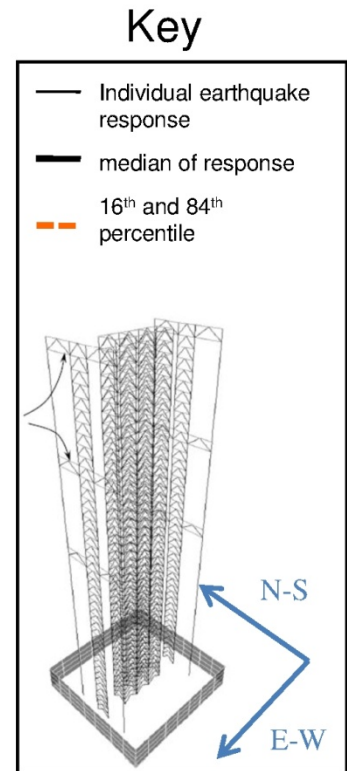
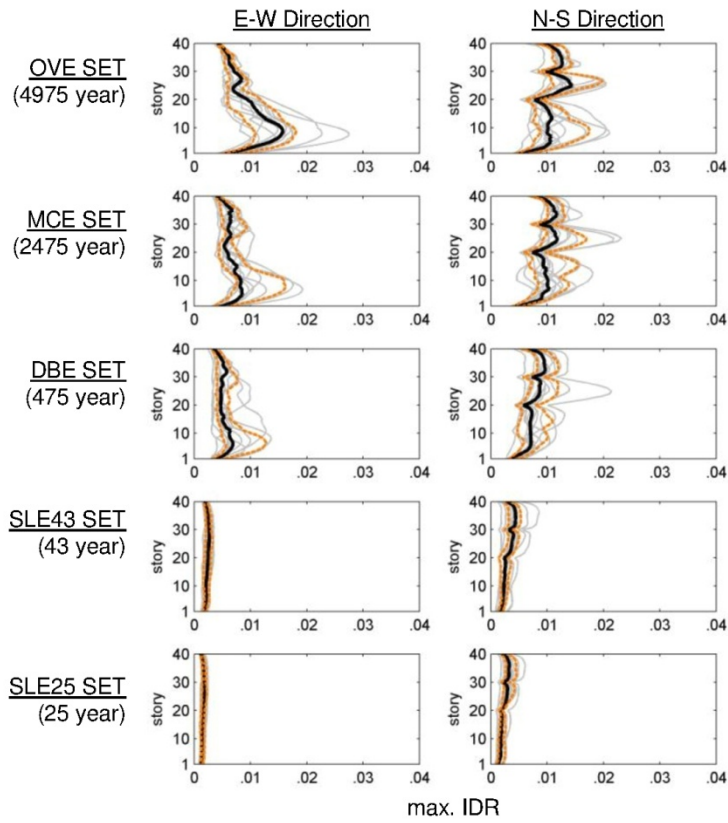

Figure 5.15 Results for Building 3B (performance-based design) in terms of maxIDR and resIDR.

maximum IDR, building IIIc



residual IDR, building IIIc

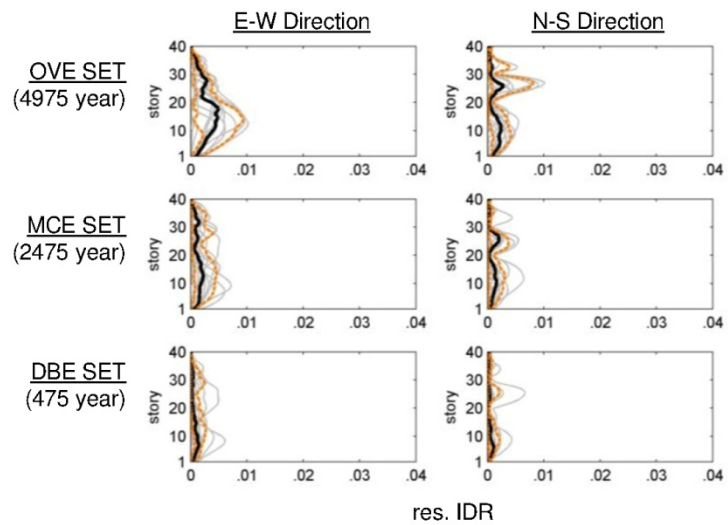

Figure 5.16 Results for Building 3C (code-based design) in terms of maxIDR and resIDR.

Peak Floor acc., building IIIa

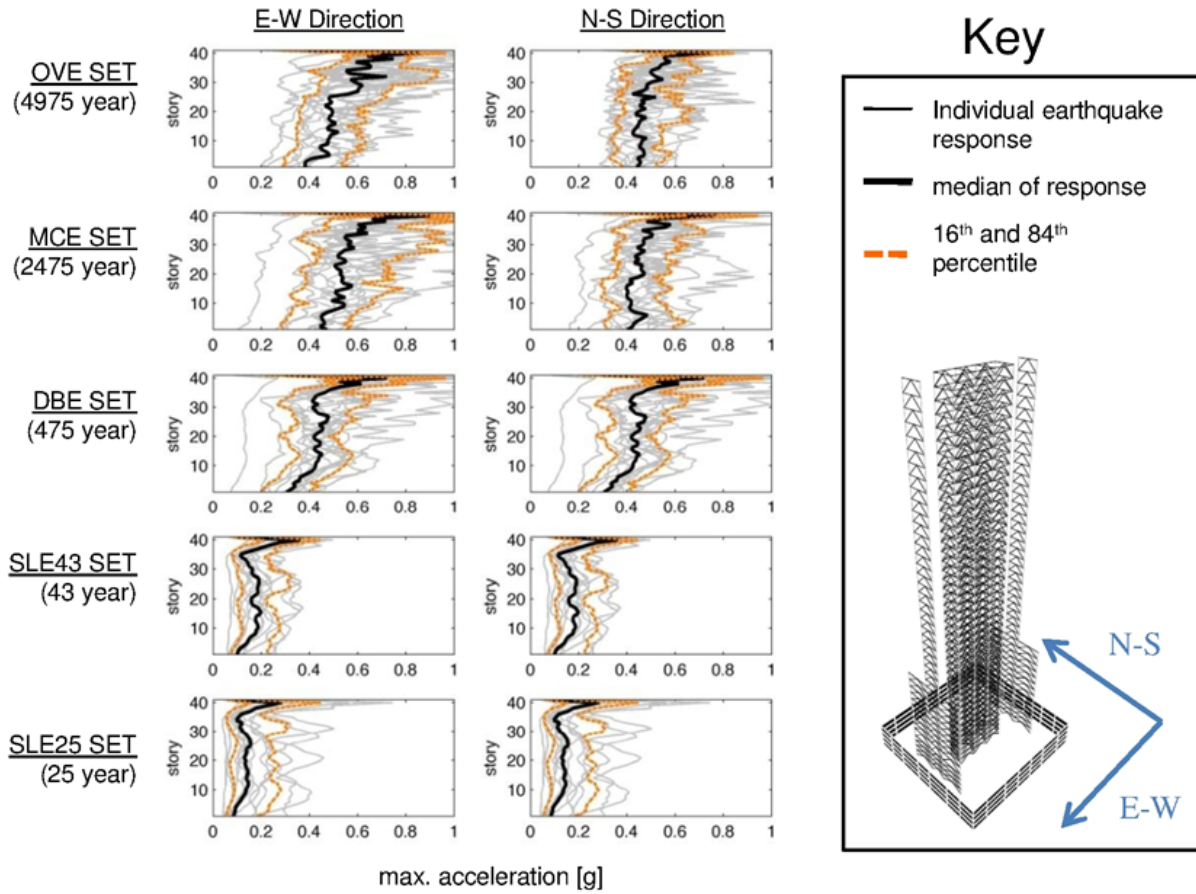

Figure 5.17 Peak floor acceleration variation along the height Building 3A in E-W and N-S directions at various hazard levels.

Peak Floor acc., building IIIb

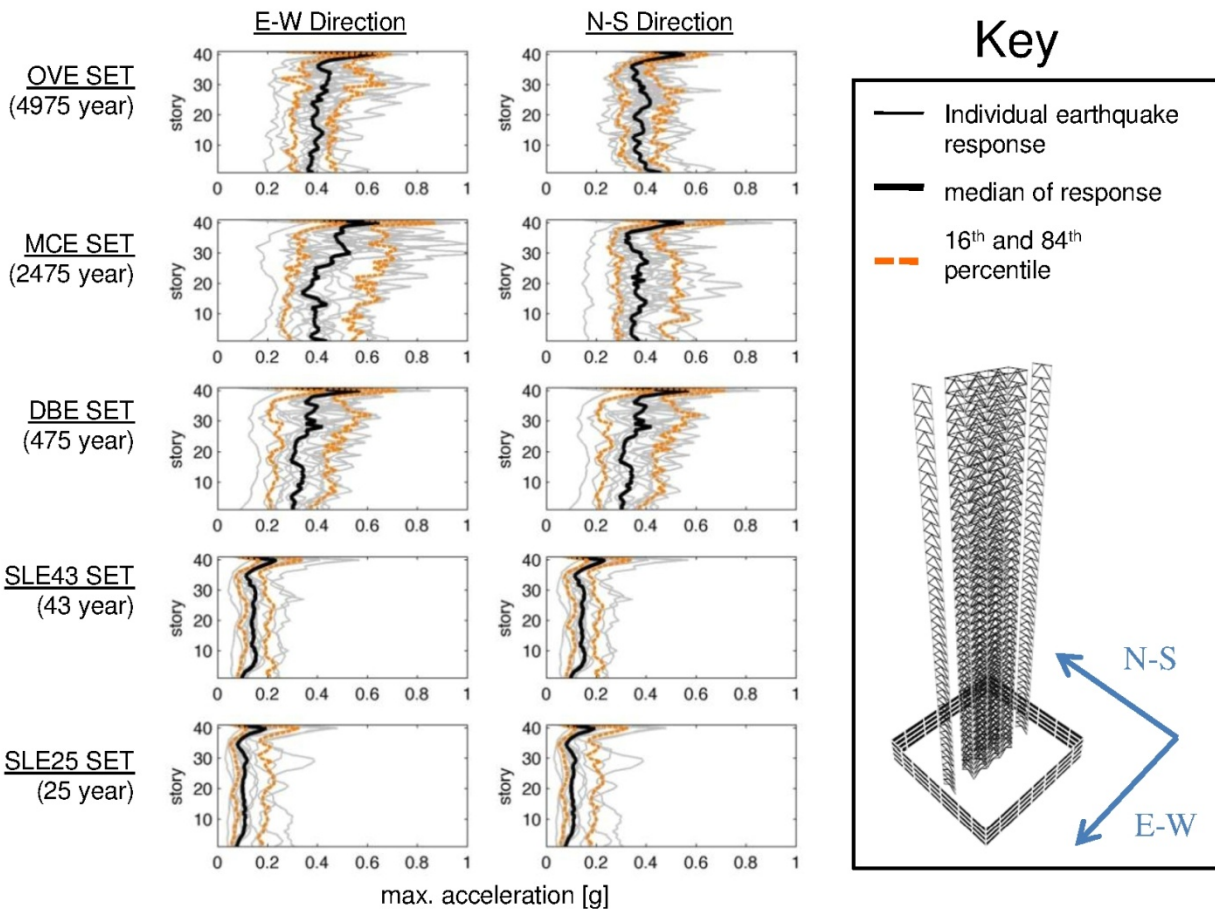

Figure 5.18 Peak floor acceleration variation along the height Building 3B in E-W and N-S directions at various hazard levels.

Peak Floor acc., building IIIc

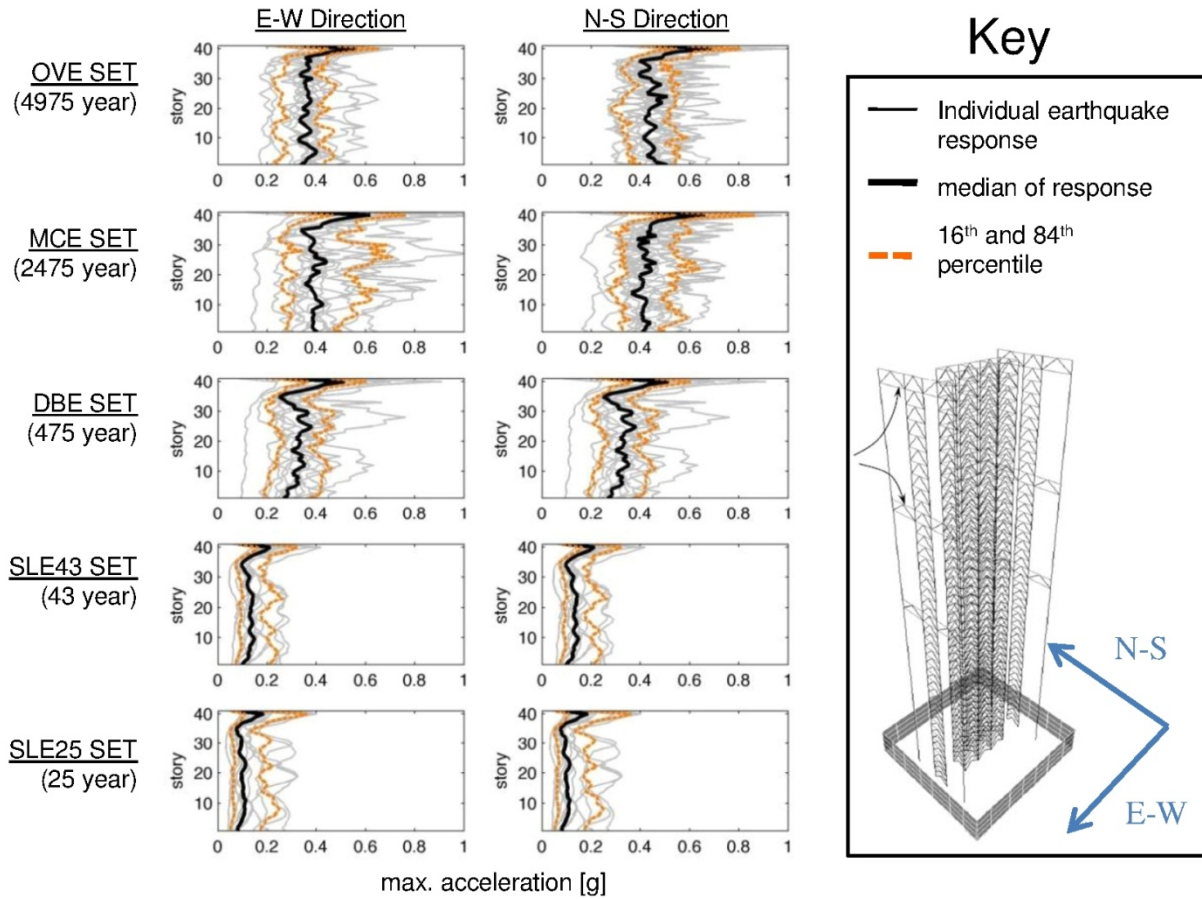

Figure 5.19 Peak floor acceleration variation along the height Building 3C in E-W and N-S directions at various hazard levels.

6 Financial Loss Estimation of the TBI Tall Building Case Studies

6.1 INTRODUCTION

Financial aspects of the case study buildings, including initial costs and projected damage repair costs associated with future earthquakes are discussed in this chapter. The relative financial loss of one building design versus another, along with the relative engineering performances covered in previous chapters, will provide a complete picture of the total performance of the suite of tall buildings investigated in this project.

As mentioned earlier, PEER researchers carried out extensive nonlinear response analyses of the TBI designs. For each design, 75 nonlinear dynamic analyses were carried out, that is, 15 analyses for five different hazard levels. The results of these nonlinear analyses were subsequently used for loss estimation.

To estimate earthquake financial losses, two approaches were carried out. The first approach—consistent with the state-of-practice loss estimation—provided the results of nonlinear RHAs to Risk Management Solutions, Inc. (RMS) for them to estimate financial losses. Additionally, a second set of financial losses was estimated using open-source financial analysis methodology according to the Applied Technology Council ATC-58 project [ATC-58 2009; Yang et al. 2009]. Worth noting is that although the state-of-the-practice and ATC-58 methodologies for loss estimation contain similar assumptions and limitations, they are also dissimilar in a number of areas. The results of initial construction costs estimated by a professional cost estimator firm are presented here, followed by the financial losses estimated according to the state-of-practice by RMS and according to the ATC-58 methodology.

6.2 INITIAL CONSTRUCTION COST ESTIMATES

Nine building designs were prepared by practicing structural engineers, as noted previously, the details of which can be found in several reports [Fry et al. 2010; Ghodsi et al. 2010; Dutta and Hamburger 2010]. Building 2B and Building 2C are identical in all aspects. A summary of building designs are presented in Table 6.1.

Table 6.1 Description of the models included in the seismic loss analyses.

Model Name	Description of the Model
Building 1A	Concrete core wall building designed according to 2006 IBC. All prescriptive provisions of the building code were observed except the height limit.
Building 1B	Concrete core wall building designed according to 2008 seismic design criteria published by the Los Angeles Tall Buildings Structural Design Council (LATBSDC). All prescriptive provisions of the criteria were observed except: 1) the minimum base shear specified by LATBSDC document was not followed. 2) Serviceability analysis was checked using earthquake with 25-year return period and 2.5% viscous damping. Only 20% of elements are allowed to reach 150% of their capacity.
Building 1C	Concrete core wall building designed with higher performance objective including a serviceability analysis using 43-year earthquake with 2.5% viscous damping, for which ductile actions are allowed to reach 150% of their capacity, with other criteria applicable.
Building 2A	Concrete dual system (special core wall with special frames) designed according to 2006 IBC. All prescriptive provisions of the building code were observed except the height limit.
Building 2B	Concrete dual system designed according to 2008 seismic design criteria published by the Los Angeles Tall Buildings Structural Design Council (LATBSDC), with exceptions noted for Building 1B.
Building 2C (same as Building 2B)	Concrete dual system designed with higher performance objective as noted for Building 1C. Building 2B was found to fully satisfy design requirements, as described in Chapter 4.
Building 3A	Steel buckling restrained braced frame building designed according to 2006 IBC. All prescriptive provisions of the building code were observed except the height limit.
Building 3B	Steel buckling restrained braced frame building designed according to 2008 seismic design criteria published by the Los Angeles Tall Buildings Structural Design Council (LATBSDC), with exceptions noted for Building 1B.
Building 3C	Steel buckling restrained braced frame building designed with higher performance objective as noted for Building 1C.

For the ATC-58 loss estimation, the initial construction costs of these nine designs were estimated by multiplying the unit square footage cost (provided by an experienced professional cost estimator firm in California, Langdon [2010a, b, c]) by the square footage area for the floors above grade shows a summary of the estimated initial construction costs used in the ATC-58 analysis.

Table 6.2 Initial structural and content costs used for the ATC-58 loss estimation; in million U.S. dollars (*).

		Design A: Code design	Design B: PBEE design	Design C: PBEE+ design
Structural Cost	Building 1: Concrete core wall	126	126	128
	Building 2: Concrete dual frame	134	159	159
	Building 3: Steel BRB	276	264	268
Total cost (structural, non- structural, and content)	Building 1: Concrete core wall	140	140	143
	Building 2: Concrete dual frame	149	174	174
	Building 3: Steel BRB	341	329	333

(*) The values here are for above the grade construction

6.3 LOSS ESTIMATES BASED ON CURRENT STATE-OF-PRACTICE

This section provides loss estimations of the TBI case studies carried out through a simulation framework developed by RMS based on the PEER performance-based earthquake engineering (PBEE) methodology [Jayaram et al. 2011]. The framework involves estimating dollar loss to structures, down-time, and the number of fatalities. Here, the focus is only on the estimating dollar losses to tall buildings and the uncertainty associated with the estimation as currently used in loss estimation practice. The three-dimensional nonlinear RHA results (Chapters 3, 4, and 5) were used to estimate the severity of physical damage and to derive associated monetary losses. In the methodology used herein, the distributions of nonlinear peak displacements and accelerations along the height of the structure were considered to estimate story-level losses. The accuracy in loss estimates, especially for tall buildings, is significantly improved by accounting for non-uniform loss distribution over the height. This is because peak story drifts (and therefore

losses) in tall buildings vary widely along the height, with the largest story drifts generally shifting from the top stories at low intensities to the bottom stories at high intensities. The approach used in this study incorporates this characteristic.

Providing loss results enables building owners to make informed decisions regarding the building systems based on the differences in losses across a range of building systems and designs. There are, however, significant epistemic uncertainties associated with the average annual loss estimates as well as the loss estimates at different return periods. The uncertainties in the loss model and the parameters used for different components of the loss model are presented here in order to facilitate the decision-making process. Epistemic uncertainties due to subjective design decisions, structural modeling, and construction quality are, however, not considered explicitly.

6.3.1 Loss Estimation Methodology

The methodology for loss calculation in this study is similar to those used by Jayaram et al. [2011] and Ramirez and Miranda [2009]. The methodology follows closely the PEER PBEE framework. Based on this framework, the probability of exceedance of a loss measure (referred to as decision variable, DV) at an intensity corresponding to a performance level, i , is estimated as follows:

$$P(DV > dv)_i = \int \int G(dv | DM) \cdot |dG(DM | EDP)| \cdot |dG(EDP | \hat{IM}_i)| \quad (6.1)$$

where $P(DV > dv)$ is the probability of exceedance of the decision variable, $G(dv|DM)$ denotes the probability of exceedance of the decision variable given a damage measure (DM) (e.g., minor damage, moderate damage), $G(DM|EDP)$ is the probability of exceedance of the damage measure given an EDP (e.g., story drift ratio, SDR), $G(EDP|\hat{IM}_i)$ is the probability of exceedance of the EDP given the median intensity (\hat{IM}) at the performance level of interest, i (e.g., MCE), and dG denotes the derivative of the probability of exceedance.

The probability of exceedance of the decision variable is estimated using numerical integration when a small number of random variables are used for the calculation. As shown later, a large number of independent and dependent random variables used to calculate the distribution of each of the variables (EDP , DM , DV) in Equation (6.1) will render numerical integration unfeasible. Therefore, in this study, a Monte Carlo simulation was used to evaluate

the integral in Equation (6.1), which simulates all the random variables in the equation and subsequently computes the mean and the variance of DV at various performance levels. The steps involved in the Monte Carlo simulation approach are discussed below; a more detailed discussion of these steps and the assumptions involved in those steps can be found in Jayaram et al. [2011].

Note that the loss estimation approach followed in this study calculates losses only at the five different performance levels for which nonlinear analysis results are available. It is assumed that the simulated losses at different performance levels are representative of the median ground motion-intensity at those levels. The estimated losses represented as a function of ground motion intensity at the different performance levels are used in this study to calculate losses of the structures when subjected to earthquakes.

6.3.2 Simulating EDPs at Each Performance Level, $dG(EDP | \widehat{IM})$

In this step, the EDPs at each story are randomly simulated from the lognormal distribution fitted to the response results at the five different performance levels (see Figure 6.1). The loss-estimation approach by Jayaram et al. [2011] fits the EDPs to the nonlinear response results as a function of ground motion intensity to simulate the EDPs at each story. The EDPs in the current approach, however, are simulated *directly* from the joint distribution of response results at all the stories. The responses of tall structures are dependent on the fundamental as well as higher modes [see, e.g., Shome and Cornell [1999]; Baker and Cornell [2006]]; therefore the distribution of EDPs of tall buildings can be estimated accurately only from a set of records that has the correct distribution of spectral accelerations at multiple periods: $\mathcal{S}_a = [S_a(T_1), S_a(T_2), \dots, S_a(T_n)]$. The direct simulation of the EDPs from the analysis results assumes that the selected 15 pairs of ground motion records adequately represent the joint distribution \mathcal{S}_a at all the periods that are important to the structure. Note that the parameters of the lognormal distribution are estimated by moment fitting the response results from 15 pairs of records at each performance level, as shown in Figure 6.1. Also assumed is that joint distribution of the story EDPs can be represented by the multivariate lognormal distribution. Therefore, both mean and standard deviation of responses at each story and the correlation coefficients of the story responses (shown in Figures 6.2 and 6.3) are needed to define the joint distribution of responses at each performance level.

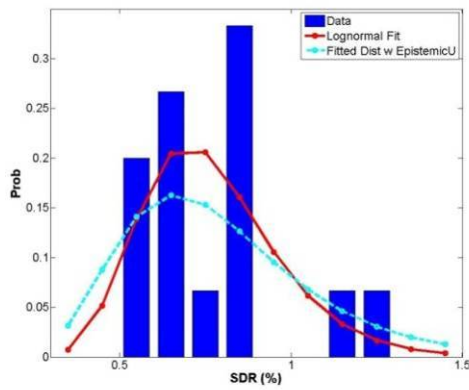

(a)

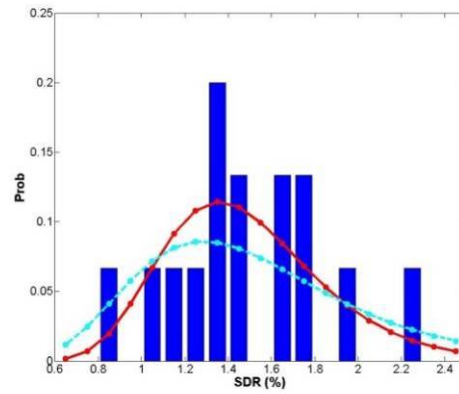

(b)

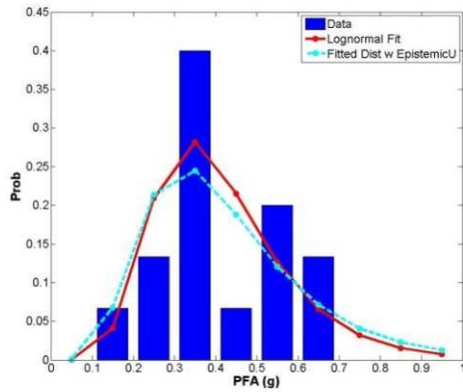

(c)

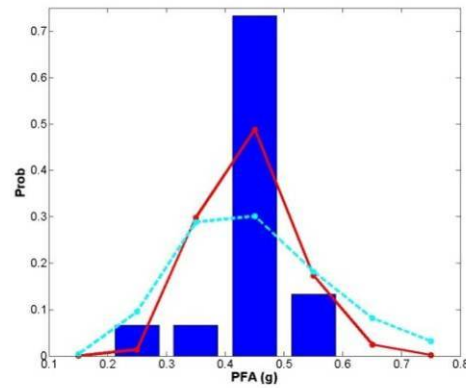

(d)

Figure 6.1 Distribution of peak SDR and PFA and lognormal fit to the data at different levels of Building 2A for the MCE ground motion. The dotted line shows distribution of the EDPs when epistemic uncertainties are considered: (a) peak SDR in first story; (b) peak SDR in fortieth story; (c) PFA at second floor; and (d) PFA at forty-first floor.

Note that the distribution of EDP obtained directly from the nonlinear analysis results represents only the aleatory uncertainty of the EDPs as a result of record-to-record variability. There are also various other sources of uncertainties present in the calculations of EDPs, including uncertainties due to modeling, software and analysis procedures, damping and material properties, etc. These uncertainties associated with lack of knowledge are the epistemic uncertainties in the estimation of EDPs. Here, the epistemic uncertainty in the estimation of EDPs was considered based on the information given in FEMA-355F [2000]; the additional epistemic uncertainties due to subjective design decisions and construction quality, however,

were not been considered. An additional random variable component was added to the EDP, whose standard deviation reflects the extent of epistemic uncertainty in the EDP. The effect of consideration of epistemic uncertainties on the distribution of EDPs is shown in Figure 6.1.

6.3.3 Simulating *DM* Corresponding to EDP, $dG(DM | EDP)$

In this approach, the damage measures of different subsystems of the buildings in each story are predicted using the fragility functions of those subsystems. The fragility functions describe the probability of reaching or exceeding damage states of various severities. The fragility functions are modeled here as a lognormal random variable with a specified mean and variance as shown below:

$$\ln(EDP_{ijk}) \sim N(\mu_{ijk} \beta_{ijk}) \quad (6.2)$$

where μ_{ijk} denotes the mean logarithmic EDP that causes the exceedance of damage state i for a subsystem j located in the k^{th} story and β_{ijk} denotes the corresponding dispersion.

The primary building subsystems that have been used in this study for the loss estimation of buildings are as follows: structural (S), nonstructural drift-sensitive (NSD), and nonstructural acceleration-sensitive (NSA). These subsystems represent assemblies of the individual components at a story such as beams, columns, etc., for the structural subsystem, and ceilings, HVAC systems, etc., for the nonstructural acceleration-sensitive subsystem. The damage to the individual components like ceilings and HVAC systems of the acceleration sensitive subsystem were not estimated separately. The probability of damage to each of the subsystems is estimated from the fragility functions for different discrete damage states. Each damage state represents a unique consequence in terms of the repair cost based on the type and severity associated with the damage state. The damage states considered in this study are minor damage, moderate damage, extensive damage, and complete damage, similar to what is defined in HAZUS [2003]. The moderate structural damage for the core-wall structure is defined by diagonal cracks appearing on most shear wall surfaces, and larger diagonal cracks with spalling of concrete at the wall ends of some shear walls. The moderate nonstructural damage of the partition walls represents large and extensive cracks requiring repair and repainting, and some partitions may require replacement of gypsum board or other. The same damage state for the suspended ceilings

represents extensive falling of tiles with disconnected and/or buckled ceiling support framing (T-bars) at a few locations.

The methodology adopted here uses peak SDR to predict the damage states of the structural subsystem and the nonstructural drift-sensitive (NSD) subsystem in each individual story. The PFA is used to predict the damage states of nonstructural acceleration-sensitive (NSA) subsystem, and peak ground acceleration (PGA) is used to predict the damage state of the NSA subsystem on the ground. The damage states estimated at each story are used to calculate the losses at each story. The story losses are then combined to estimate the total building loss.

6.3.4 Fragility Functions for Structural Subsystems

The fragility functions for the structural subsystems are developed based on the limiting SDR stipulated in different codes and guidelines, and the uncertainty (or β) as defined in HAZUS or ATC-58. Some of the important guidelines consulted in this study are ATC-58 [2010], FEMA-273 [1997], FEMA-450 [2003], and the SEAOC Blue Book [1999]. The mean fragility function for the structural subsystem of the dual system (Building 2A and Building 2B) for extensive damage is shown in Figure 6.5(a), together with the three fragility functions proposed by the engineering firms.

The additional fragility functions shown in the figure include: (1) for coupled shear wall structures based on the drift limits corresponding to the life-safety performance level as defined in the SEAOC Blue Book [1999]; (2) for concrete wall structures based on drift limits of the life safety performance level leading to failure of the coupling beams, and some flexural and shear cracks of the walls as defined in FEMA-273, which is considered as the mean fragility function; and (3) for moderate damage in concrete shear wall structures as defined in HAZUS. The damage state of the fragility functions represents the moderate damage of the dual-system building leading to some of the shear walls exceeding yield capacity with large diagonal cracks. The fragility functions from each of the sources illustrate the epistemic uncertainty in the damage states, and this information has been used to explicitly define the epistemic uncertainty in the damage states and, consequently, the loss results.

6.3.5 Fragility Functions for Nonstructural Drift-Sensitive Subsystems

The fragility functions for non-structural subsystems (both drift and acceleration sensitive) are developed based on the information in HAZUS [2003], Ramirez and Miranda [2010], Aslani and

Miranda [2005], and ATC-58 [2009]. The subassembly of the fragility functions for the generic nonstructural drift-sensitive (NSD) subsystem for extensive damage (DS3) is shown in Figure 6.5(b). For illustration, alternative fragility functions corresponding to the extensive damage state for the nonstructural drift-sensitive subsystem as well as partition wall component of the subsystem are also shown in the figure. The component fragility function for the partition wall illustrates the variation of the individual component fragility. The sources for these fragility functions include: (1) generic NSD components by Ramirez and Miranda [2009], (2) generic NSD components as defined in HAZUS [2003]; and (3) gypsum-board partitions as defined by Aslani and Miranda [2005] for the damage state that would require replacing some of the panels and the frames. Gypsum board is one of the several different components of NSDs. The variation of the probability of the damage states for different sources is considered by specifying the epistemic uncertainty in the damage states.

6.3.6 Fragility Functions for Nonstructural Acceleration-Sensitive Subsystems

Some important fragility functions used to develop the function for the subsystem as well as for some important components include: (1) generic nonstructural acceleration-sensitive subsystems (NAS) as defined by Ramirez and Miranda [2009]; (2) generic NAS subsystems as defined in HAZUS [2003]; (3) suspended acoustical ceilings as developed by Aslani and Miranda [2005] (component); and (4) HVAC, MEP, ceilings, and other miscellaneous components as defined in ATC-58 [2009] (component). The mean fragility function for the generic NAS subsystem corresponding to the extensive damage state is shown in Figure 6.5(c).

The component fragility function in the figure illustrates the variation of the fragilities among different components of the subsystem. Note that the fragility curves are usually developed based on experimental data or damage data from historical earthquakes and typically vary from source to source (depending on data source, method of fragility function development, etc.). The epistemic uncertainty in the fragility functions captures this variability. In order to illustrate this uncertainty at the component level, the fragility functions for the suspended lay-in acoustic tile ceiling (component) from the following sources are plotted in Figure 6.6:

- Average fragility function developed by Aslani and Miranda [2005].
- Fragility functions defined in ATC-58 for different sizes, e.g., 250 sq ft to 2500 sq ft, and for different support conditions, e.g., vertical hanging wires, vertical hanging wires with diagonal wires, and compression posts, etc.

6.3.7 Correlation of Damage States

The fragility functions are used to simulate the multiple damage states of the three major subsystems using a Monte Carlo simulation. These damage states are partially correlated. Because the damage states are discrete, simulation of partially correlated discrete damage states is challenging. However, Baker [2008] has shown that it is possible to easily introduce the correlation between discrete damage states by defining the fragility functions as “damage capacity.” The same approach is adopted here for simulating the losses. The damage capacity (C) is defined as a lognormal random variable with median θ and dispersion β , i.e., $C \sim \text{LN}(\theta, \beta)$. A Monte Carlo simulation is then used to generate samples of damage capacity, C_i . A component would be in a specific damage state if the specified demand level D is greater than the simulated damage capacity, C_i . Therefore, the multivariate lognormal damage capacity should simulate adequately the correlation of multiple damage states of a component.

6.3.8 Simulation of DV Given DM , $dG(DV | DM)$

This step involves simulating the subsystem repair cost as well as losses due to collapse and demolitions (called decision variable, DV , in the PEER methodology) corresponding to the DM simulated in the earlier step. The loss costs are necessary for calculating the mean and variability of the building repair cost at different performance levels (which is required for developing the vulnerability functions). It is assumed that the loss of components at a given damage state is a lognormal random variable. The mean of the replacement cost of the different components of high-rise tall buildings is based on the information provided by Ramirez and Miranda [2009]. The variability of the repair cost is based on the costs for a broad category of contractors and subcontractors like concrete work, finishes, mechanical, electrical, etc. The logarithmic standard deviation of the repair costs of the subcontractors varies from 0.6 to 0.9. The repair costs of different components for different damage states are expected to be correlated because of the common category of contractors/sub-contractors involved in the repair and the similar materials used for the repair. Ramirez and Miranda [2009] have shown that the costs of different subcontractors are typically highly positively correlated. The univariate distribution of construction costs are shown in Figure 6.7, and the joint distributions of costs of two components illustrating the correlation are shown in Figure 6.8. The results were obtained by simulating the costs of different contractors from the joint distribution of costs of high-rise buildings.

In response to strong ground shaking structures may collapse or experience excessive residual drifts necessitating demolition. These quantities are not directly used in this study, and the maximum of peak SDR among all the stories is used here to predict the collapse of structures and demolition due to excessive drifts. It is assumed that when the maximum of simulated peak SDR is high, structures will either collapse or will be demolished.

6.3.9 Correlation between Random Variables

The correlation between different random variables plays a significant role in determining the variability of losses at a given ground motion intensity level. If correlation between random variables is high, the variability of the loss results will be high and vice versa. The correlation between EDPs over the height of the structure is obtained directly from the nonlinear analysis results (Figure 6.1). The correlation between building repair costs for different components across different damage states is estimated from the correlations between subcontractor costs (Figure 6.8). The correlations between the capacities of different components at different damage states are dependent on the quality of design and construction. It is assumed that the capacity of structural components is strongly correlated as there is typically only one major contractor for the construction of structural components. The correlation for non-structural components, on the other hand, is weaker because of the involvement of a large number of different types of contractors (e.g., plumbing, HVAC, and finishing work are carried out by different contractors with very different skill sets, leading to weaker correlations between the capacities of these components). Since the information about the correlation of capacities between different components of buildings is not available, engineering judgment has been used to estimate the correlation of the capacities over the height.

6.3.10 Development of Vulnerability Functions

As stated earlier, the losses of different subsystems of the buildings are calculated using a Monte Carlo simulation (by first sampling *EDP*, then *DS* and finally *DV* at the different performance levels). These subsystem losses are summed to calculate the loss cost of the entire building, then these results are used to calculate the mean loss ratio of the entire building as a function of ground motion intensity. The resulting function is known as the building vulnerability function. The simulated loss results for Building 2A are shown in Figure 6.9. The standard deviation of the loss results at a given intensity provides the information of the variability in the loss results. The

information about the mean and standard deviation of the loss results as well as the assumption of beta distribution of losses at a given ground motion intensity completely defines the distribution of the loss results. Insurance claims data for the historical events indicate that beta distribution is a good fit to the loss data. The vulnerability function is used to estimate the losses for the simulated probable future earthquakes in order to calculate different loss matrices, which are used by insurers and risk managers for managing earthquake risks. The typical loss matrices are the average annual loss and the losses at different return periods.

6.3.11 Loss Results

Figure 6.10 shows the RMS ground-up losses (i.e., the entire amount of an insurance loss, including deductibles, before application of any retention or reinsurance) for the code-designed Buildings 2A and 3A relative to the losses to Building 1A at a generic site in Los Angeles at different return periods. Note: differences in the replacement costs of different building systems and designs were not considered when comparing the loss results, with the assumption that the same replacement cost in these buildings was the same. The results show that the core-wall building (Building 1A) suffered the largest losses, indicating that the relative seismic risk of losses for the dual-system (Building 2A) and the BRB system (Building 3A) about 30% to 40% lower than for the core-wall system (Building 1A).

The average annual loss (or the pure premium) of different code-designed buildings relative to that of the core-wall building is shown in Figure 6.11. This figure provides some guidance to building owners about the differences in the insurance premiums across different building systems for code-designed structures. The loss of all the building systems and designs relative to the losses of the code-designed core-wall building (Building 1A) at different return periods are compared in Figure 6.12. Note the differences in the losses for different building systems and also for different design provisions, demonstrating a significant advantage in carrying out performance-based design over the prescriptive-code designs in terms of losses. The relative loss results combined with information about the initial building cost will aid building owners to make informed choices in terms of building systems and designs. Incidentally, the loss results in Figure 6.12 also highlight the superior performance of designs based on the PEER Guidelines [PEER, 2010].

It is well recognized that the relative contribution of structural and non-structural repair costs to the total building repair cost varies significantly with the intensity of ground motion. The

distribution of repair cost of Building 2A for various subsystems at a low intensity (the SLE) and at a high intensity (the MCE) is shown in Figure 6.13. The figure shows that most of the repair cost from the SLE is the result of acceleration-sensitive nonstructural subsystems, whereas the repair cost at the MCE is dominated by the structural and nonstructural drift-sensitive subsystems. This also implies that the small-magnitude and short-distance earthquakes or large-magnitude and long-distance earthquakes would damage primarily acceleration-sensitive components (like false ceilings, HVAC equipment, and contents like shelves, etc.). Losses from large-magnitude short-distance earthquakes, on the other hand, will primarily damage displacement-sensitive subsystems (i.e., structural and non-structural drift-sensitive subsystems) as shown in Figure 6.13. Note that the observation made here is building-specific (i.e., applicable to Building 2A and may be applicable to dual systems); it will not be applicable to other building systems like BRBs.

Figure 6.14 shows that the distribution pattern of repair costs of Building 2A varies significantly over the height of the building, with the pattern changing with increasing intensity of the ground motion. Note that the amplification of PFAs at the basement is likely an artifact of some modeling assumptions, and these results are ignored here for the purpose of interpreting the loss results. Figure 6.14 shows that there was a significant concentration of losses in the top few stories (whiplash effect), and a large fraction of losses was due to the non-structural components. As the intensity increased, losses began spreading from top to bottom, and the distribution changes from the acceleration-sensitive components to the drift-sensitive components. The figure also shows that the losses to the structural components become significant at high intensities since repairing the structural components is a complex process and often costs significantly more than the cost of replacing a component.

6.3.12 Uncertainty in Loss Results

The calculation of loss ratios as shown in Figures 6.10 to 6.12 considers only the aleatory uncertainty in the loss results. However, there is a significant epistemic uncertainty in the estimation of the EDPs at a given intensity of ground motion, in the damage states for a given EDP, as well as in the repair cost for a given damage state. Epistemic uncertainty is associated with a lack of knowledge of the quantities or processes identified with a system; it can be subjective, and is reducible with additional information. The epistemic uncertainty due to modeling assumptions, data quality, and availability is potentially the biggest source of

difference in losses between various models. Because of all these different sources of uncertainties, the loss results at different return periods can vary significantly from those shown in the figures (e.g., if an alternate structural subsystem fragility function is used or if a higher or lower repair costs is used). In order to estimate the uncertainty in the loss results, the losses at different return periods are calculated also for the mean \pm 1-sigma uncertainty (epistemic) of the vulnerability function (i.e., for the 16th -percentile and 84th-percentile damage function) of the code-designed buildings. The uncertainty in the loss results due to the epistemic uncertainty in the estimation of the vulnerability functions relative to the expected loss results of the code-designed Building 1A is shown in Figure 6.15. The results indicate that although the performance of the dual system is the best among all the three building systems, the loss results of the dual system and BRB are within statistical noise levels (more precisely, the losses of the dual system are not statistically significantly different from those for the BRBs), given all the limitations (discussed in the following section) of the loss estimation methodology in the present study.

6.3.13 Summary of the State-of-the-Art Loss Estimation

The loss estimation results indicate, as far as financial loss is concerned, the performance of the dual-system is the best among the systems considered in this study. With respect to the different designs, the buildings designed following the PEER performance-based seismic design guidelines [PEER, 2010] show superior performance. Considering the epistemic uncertainty in the loss results, however, the difference in the performance of the dual-system building and the BRB frame building is not statistically significant. It is expected that the loss results will enable building owners to make a judicious choice of the building structural system and the design criteria.

6.3.14 Key Assumptions and Limitations of the State-of-the-Practice Loss Estimation

Some important assumptions in the RMS loss estimation methodology are highlighted here.

Repair Cost: It has been assumed that the repair cost for complete damage of the structural components is 125% more than the cost of new construction of those components. This estimation is based on the repair cost of the damaged components as well as the cost associated with replacing/repairing some of the undamaged components during the repair work (such as the

costs associated with removing false ceilings while repairing damaged connections). On the other hand, the repair cost for complete damage of the nonstructural components is assumed to be only 20% more than the cost of new construction. These assumptions have the greatest impact at high performance levels for which the probability of complete damage is high.

Consideration of Collapse and Demolition of Buildings: In response to strong ground motion, buildings may collapse or require demolition due to excessive residual drifts. Directly estimating these probabilities was not possible, however, because the necessary analysis results associated with residual-drift and collapse were not available. The maximum of the peak SDR over all the stories is used here to predict the potential for collapse or demolition due to excessive drifts. Incorporating this possibility increases the loss results at the OVE level by approximately 30%.

Higher Standard Deviation in the Loss Results: The standard deviation of the losses estimated from simulation has been increased to capture variability associated with:

- The quality of design and construction methods
- The insurance claim adjustment process
- Other issues that have not been modeled explicitly

The uncertainties at low hazard levels (e.g., at the SLE) have been increased significantly, whereas the increase in the uncertainties at high intensities (e.g., at the MCE) is modest. These changes tend to increase the loss results at low return periods.

Content Loss: Content losses have not been considered in the RMS study for evaluating the performance of the buildings. The consideration of contents in loss calculations may change the observations made here.

Representation of the Vulnerability Functions: The ground motions used in this study have been selected such that their average spectra match the UHS over a period range of 1-7.5 sec at five different performance levels. RMS estimated the loss at different return periods by integrating the hazard curve for the spectral acceleration at a period close to the fundamental period of the structure $S_a(T_1)$ and the vulnerability functions developed based on the analysis results as a function of $S_a(T_1)$. Because the analyses were not carried out for records conditioned on $S_a(T_1)$, the representation of the vulnerability functions as a function of $S_a(T_1)$ for loss calculations would likely overestimate the losses. Additional discussion on this issue can be found in Jayaram et al. [2011].

Correlation: Correlations between the different random variables involved in the loss calculations play a significant role in determining the variability of losses at a given ground motion intensity level. When the correlation between two random variables is high, if one instance of a random variable is higher than its mean, the other will also tend to be higher than its mean. The methodology followed here considers not only the correlation between the EDPs as observed in the structural analysis results, but also the correlation between the damage states and the repair costs. This additional step increases the variability in the loss results and, therefore, the loss results at long-return periods.

High-Frequency Components of Ground Motion: The ground motions used in this study were selected such that the average of their spectra matches the target spectrum from 1 to 7.5 sec. The spectral accelerations at periods shorter than 1 sec may have some impact on the PFA in particular, which may slightly bias the estimated PFA. Since most of the losses at low intensities are due to the damage of the acceleration-sensitive components, it is expected that the losses at low intensities would also be slightly biased.

Adjustment of the Dispersion of the Loss Results: It is expected that there would be variability in the response spectra of ground motions at a site corresponding to any intensity level. This variability in the spectra will also introduce variability in the response of structures and so in the losses to those structures. The variability in the loss results were adjusted to take into account an additional variability of ground motion around the target spectrum.

Interpreting the Loss Results: In Figure 6.10, a loss with return period X (where X equals 50, 250, 500 years) is the loss that occurs once every X years on average (using a Poisson assumption for loss recurrence). This loss can potentially be very different from the loss that occurs during a ground-motion that has a return period of X years. For instance, the PEER ground-motions corresponding to the DBE level have a return period of 475 years. The loss computed directly using these DBE ground motions will not necessarily match the 475-year return period loss as shown in Figure 6.10. The loss return period is always less or equal to the hazard return period at which the loss calculations are carried out [Shome and Cornell (1999); Cornell and Krawinkler (2000)]. The difference between these two return periods is primarily dependent on the slope of the hazard curve, the slope of the vulnerability function and the uncertainty in the losses at a given intensity. In fact, these two return periods will be identical when the loss at a particular hazard level has zero variance.

6.4 LOSS SIMULATION STUDY: ATC-58 APPROACH

6.4.1 Introduction

A detailed seismic loss simulation for the TBI buildings was conducted using the methodology presented in the ATC-58 report [ATC-58 2009]. The methodology uses a Monte Carlo simulation procedure to systematically analyze the loss of a facility by calculating the repair actions and costs from each component in the building. All case study buildings presented in this report were analyzed for seismic losses under five seismic hazard levels: SLE25, SLE43, DBE, MCE and OVE corresponding to return periods 25, 43, 475, 2475 and 4975 years, respectively. Table 6.1 summarizes the building designs included in this study.

6.4.2 Selection of the Performance Groups and Fragility Curves

As outlined in the ATC-58 methodology, major structural and non-structural components with similar response affected by the same EDP (such as interstory drift or floor acceleration) are grouped into the same performance groups. The response of each component in the performance group is assumed to have the same response under the same EDPs. Fragility curves, which represent the probability that the components exceed a certain damage state, are obtained from the database provided by the ATC-58 project team. Multiple fragility curves were defined for each performance group under different damage states. Additionally, the ATC-58 team provided the associated repair actions and repair cost for each component in each damage state.

Tables 6.3-6.5 show the performance groups identified for Buildings 1, 2, and 3, respectively. As presented in Table 6.3, a total of 1765 performance groups were identified for Building 1. This includes shear walls at all floors, shear wall boundary elements at all floors, link beams at all locations, gravity columns of all floors, curtain walls at all floors, interior partitions at all floors, elevators, and contents at all floors. The fragility relations for each of the performance groups presented in Table 6.3 are summarized in Figures 6.16-6.23. Building 2 uses the same fragility curves as presented in Figures 6.16-6.23, except the MRF, which is presented in Figure 6.24. Building 3 uses a steel BRB frame, where the only components that are expected to experience significant damages are listed in the Table 6.5. These components include: the steel BRBs at all floors, curtain walls at all floors, interior partitions at all floors, ceilings at all floors, elevators, and the contents at all floors. Building 3 used the same fragility curves as presented in

Figures 6.16-6.23, except for the BRB and ceiling, which are presented in Figures 6.25 and 6.26, respectively.

6.4.3 Results of Loss Simulation

The nonlinear dynamic responses of the buildings subjected to the five hazard levels, were analyzed using computer program Perform-3D [CSI 2009]. The maximum EDPs for each component were identified from nonlinear RHAs. The statistical distributions for each EDP at each hazard level were analyzed. A systematic procedure presented by Yang et al. [2009] was used to generate an array of synthetic EDPs. The generated EDPs were used in the ATC-58 loss simulation methodology. Figures 6.27-6.34 list the repair cost distributions for Buildings 1A, 1B, 1C, 2A, 2B/2C, 3A, 3B, and 3C, respectively. Figures 6.35-6.74 present the detailed deaggregations of the median repair costs contributed from each performance group in each building at each seismic hazard level.

The median repair costs for the buildings at different earthquake hazard levels are summarized in Tables 6.6-6.10. The corresponding repair cost ratios normalized using the initial construction data (Table 6.2) are summarized in Tables 6.11-6.15. The probable maximum loss (PML) was estimated using a 90% confidence level of not exceeding the repair cost at different earthquake hazard levels. These estimated losses were normalized using the initial construction data (Table 6.2) and summarized in Tables 6.16-6.20. Both initial structural and content costs were included in the analysis. In general, as the design methodology shifts from Design A to B to C, the median repair cost for the building reduces. For all hazard levels, Building 3C had the lowest median repair cost. Building 2A had the highest median repair cost for all hazard levels, except at the DBE and MCE shaking intensities. In these two hazard levels, Building 1A had the highest median repair cost. By comparing to the median repair cost, it is concluded that the total repair cost of the steel BRB buildings was the least expensive.

Table 6.21 summarizes the mean annualized repair cost for the buildings. This number represents the average repair cost per year for all buildings, considering all hazard levels. The results show that Building 1 had highest mean annualized repair cost followed by Building 2 then Building C. In general, the mean annualized repair cost decreased as the design shifted from A to B to C, except in Building 1, where Design B has the highest mean annualized repair cost followed by Design C then A. Note that the residual drift, which might have significant impact to the total repair cost in Building 3, was not included in this calculation.

If we assume the mean annualized repair costs are equivalent to required insurance premiums to be paid annually, we can calculate the net present value of the insurance premiums given a payment period and assumed time value of money. Assuming a period of 50 years and interest rate of 0.03, the present value of insurance premiums is given in Table 6.22.

Total Cost can be defined as the initial construction cost plus the net present value of insurance premiums. Summing the values from Tables 6.2 and 6.22, the Total Costs are listed in Table 6.23.

Table 6.24 compares costs of Designs A, B, and C relative to the cost of Design A for the Buildings 1, 2, and 3, respectively. For Building 1, the performance-based designs had negligible influence on Total Cost. For Building 2, the performance-based designs added 15% to the Total Cost. For Building 3, the performance-based designs resulted in minor reductions in Total Cost. Note that these results are insensitive to the assumed time value of money. Note also that the performance-based designs were not oriented toward optimization of Total Cost, but instead were oriented toward more reliable performance by more explicit representation of the building properties in the design process. Furthermore, there was no intent of the performance-based designs to achieve superior performance but, rather, to more reliably achieve Occupancy Category II performance objectives.

Figures 6.35-6.49 show the deaggregation of the repair cost for Building 1. At the SLE25 hazard level, the repair cost for Building 1A resulted mostly from the interior partition performance groups. As the shaking intensity increased to SLE43, additional interior partition performance groups contributed to the total repair cost for Building 1A. At the DBE shaking intensity, all interior partitions and contents performance groups were damaged. In addition, some shear wall web performance groups also contributed to the total repair cost. As the shaking intensity increased to the MCE level, additional shear wall web, slab-column connections, and curtain walls were damaged and contributed to the total repair cost. As the shaking intensity increased to the OVE level, similar observed trends were repeated, but the repair cost and damage states were more severe.

Similar to Building 1A, Building 1B sustained minor damage to the interior partition performance groups at the SLE 25 shaking intensity. As the shaking intensity increased to the SLE 43 level, some damage to the content was observed in Building 1B that was not observed in Building 1A, explaining why Building 1B had a higher repair cost than Building 1A at this

shaking intensity. At the DBE, MCE, and OVE shaking levels, Building 1B had damage similar to that of Building 1A, except the repair cost and damage states were more severe.

Damage in Building 1C was similar to that in Buildings 1A and 1B, with the major difference being that Building 1C sustained little damage to its shear wall webs and slab-column connections but more damage to coupling beams. The repair costs for the interior partitions and contents performance groups seemed to peak beginning at the DBE shaking level.

Figures 6.50-6.59 show the deaggregation of the repair cost for Building 2. Building 2A began to experience damage to the shear wall webs and interior partitions even at the SLE25 shaking intensity. As the shaking intensity increased to SLE 43, more shear wall web and interior partition damage contributed to the total repair cost. At the DBE level, all interior partitions and contents were damaged. In addition, more shear wall webs began to contribute to the total repair costs. As shaking intensity increased to the OVE level, additional damage occurred to the moment resisting frames. The damage trend for Building 2B was very similar to Building 2A for all hazard levels considered.

Figures 6.60-6.74 show the deaggregation of the repair cost for Building 3. At the SLE25 hazard level, the repair cost for Building 3A resulted mostly from the interior partitions. At the SLE43 hazard level, additional interior partitions contributed to the repair cost. At the DBE shaking intensity, all interior partitions and contents were damaged. As the shaking intensity increased to the MCE level, additional interior partition damage contributed to the total repair cost. At the OVE level, BRB frames were damaged and contributed to the total repair cost. The damage trend is similar for Buildings 3A, 3B, and 3C for all hazard levels considered. It is worth noting that Building 3C has the lowest repair cost of all hazard levels considered.

Table 6.3 Summary of the performance groups included in the loss analysis for Building 1.

Group numbers	Performance groups	Items
1 to 470	SW	Shear wall webs at all floors
471 to 1222	SWBE	Shear wall boundary elements at all floors
1223 to 1482	LB	Coupling (link) beams at all locations
1483 to 1529	GC	Slab-column connections at all floors
1530 to 1623	CW	Curtain walls at all floors
1624 to 1717	IP	Interior partitions at all floors
1718	Elevator	Elevators
1719 to 1765	Content	Contents at all floors

Table 6.4 Summary of the performance groups included in the loss analysis for Building 2.

Group numbers	Performance groups	Items
1 to 430	SW	Shear wall webs at all floors
431 to 1118	SWBE	Shear wall boundary elements at all floors
1119 to 1376	LB	Coupling (link) beams at all locations
1377 to 1423	GC	Slab-column connections at all floors
1424 to 1517	MRF	Moment resisting frames at all floors
1518 to 1611	CW	Curtain walls at all floors
1612 to 1705	IP	Interior partitions at all floors
1706	Elevator	Elevators
1707 to 1753	Content	Contents at all floors

Table 6.5 Summary of the performance groups included in the loss analysis for Building 3.

Group numbers	Performance groups	Items
1 to 80	BRB	BRBs at all floors
81 to 160	CW	Curtain walls at all floors
161 to 240	IP	Interior partitions at all floors
241 to 280	Ceiling	Ceilings at all floors
281	Elevator	Elevators
282 to 321	Content	Contents at all floors

Table 6.6 Median repair cost in million U.S. dollars (SLE 25).

	Design A: Code design	Design B: PBEE design	Design C: PBEE+ design
Building 1: Concrete core wall	2.74	2.70	2.35
Building 2: Concrete dual frame	2.88	2.39	2.39
Building 3: Steel BRB	1.73	1.19	1.19

Table 6.7 Median repair cost in million U.S. dollars (SLE 43).

	Design A: Code design	Design B: PBEE design	Design C: PBEE+ design
Building 1: Concrete core wall	4.08	4.33	3.47
Building 2: Concrete dual frame	4.25	3.49	3.49
Building 3: Steel BRB	2.50	2.02	1.68

Table 6.8 Median repair cost in million U.S. dollars (DBE).

	Design A: Code design	Design B: PBEE design	Design C: PBEE+ design
Building 1: Concrete core wall	15.03	15.07	11.98
Building 2: Concrete dual frame	13.31	10.63	10.63
Building 3: Steel BRB	8.28	7.58	7.18

Table 6.9 Median repair cost in million U.S. dollars (MCE).

	Design A: Code design	Design B: PBEE design	Design C: PBEE+ design
Building 1: Concrete core wall	22.27	21.29	17.73
Building 2: Concrete dual frame	18.47	18.05	18.05
Building 3: Steel BRB	10.49	10.37	9.20

Table 6.10 Median repair cost in million U.S. dollars (OVE).

	Design A: Code design	Design B: PBEE design	Design C: PBEE+ design
Building 1: Concrete core wall	25.02	24.48	21.87
Building 2: Concrete dual frame	25.62	25.81	25.81
Building 3: Steel BRB	11.72	12.77	10.25

Table 6.11 Median repair cost normalized using initial construction cost (SLE 25).

	Design A: Code design	Design B: PBEE design	Design C: PBEE+ design
Building 1: Concrete core wall	2.0%	1.9%	1.6%
Building 2: Concrete dual frame	1.9%	1.4%	1.4%
Building 3: Steel BRB	0.5%	0.4%	0.4%

Table 6.12 Median repair cost normalized using initial construction cost (SLE 43).

	Design A: Code design	Design B: PBEE design	Design C: PBEE+ design
Building 1: Concrete core wall	2.9%	3.1%	2.4%
Building 2: Concrete dual frame	2.9%	2.0%	2.0%
Building 3: Steel BRB	0.7%	0.6%	0.5%

Table 6.13 Median repair cost normalized using initial construction cost (DBE).

	Design A: Code design	Design B: PBEE design	Design C: PBEE+ design
Building 1: Concrete core wall	10.7%	10.8%	8.4%
Building 2: Concrete dual frame	8.9%	6.1%	6.1%
Building 3: Steel BRB	2.4%	2.3%	2.2%

Table 6.14 Median repair cost normalized using initial construction cost (MCE).

	Design A: Code design	Design B: PBEE design	Design C: PBEE+ design
Building 1: Concrete core wall	15.9%	15.2%	12.4%
Building 2: Concrete dual frame	12.4%	10.4%	10.4%
Building 3: Steel BRB	3.1%	3.2%	2.8%

Table 6.15 Median repair cost normalized using initial construction cost (OVE).

	Design A: Code design	Design B: PBEE design	Design C: PBEE+ design
Building 1: Concrete core wall	17.8%	17.5%	15.3%
Building 2: Concrete dual frame	17.2%	14.9%	14.9%
Building 3: Steel BRB	3.4%	3.9%	3.1%

Table 6.16 PML cost normalized using initial construction cost (SLE 25).

	Design A: Code design	Design B: PBEE design	Design C: PBEE+ design
Building 1: Concrete core wall	5.2%	5.1%	4.4%
Building 2: Concrete dual frame	4.7%	3.4%	3.4%
Building 3: Steel BRB	1.4%	1.2%	1.1%

Table 6.17 PML normalized using initial construction cost (SLE 43).

	Design A: Code design	Design B: PBEE design	Design C: PBEE+ design
Building 1: Concrete core wall	4.5%	4.8%	4.1%
Building 2: Concrete dual frame	4.8%	3.5%	3.5%
Building 3: Steel BRB	1.5%	1.2%	1.1%

Table 6.18 PML normalized using initial construction cost (DBE).

	Design A: Code design	Design B: PBEE design	Design C: PBEE+ design
Building 1: Concrete core wall	14.2%	14.8%	11.9%
Building 2: Concrete dual frame	12.7%	8.5%	8.5%
Building 3: Steel BRB	3.1%	3.1%	2.7%

Table 6.19 PML normalized using initial construction cost (MCE).

	Design A: Code design	Design B: PBEE design	Design C: PBEE+ design
Building 1: Concrete core wall	20.3%	20.4%	16.4%
Building 2: Concrete dual frame	17.7%	15.1%	15.1%
Building 3: Steel BRB	3.9%	4.0%	3.5%

Table 6.20 PML normalized using initial construction cost (OVE).

	Design A: Code design	Design B: PBEE design	Design C: PBEE+ design
Building 1: Concrete core wall	22.8%	23.3%	19.6%
Building 2: Concrete dual frame	22.6%	20.4%	20.4%
Building 3: Steel BRB	4.3%	5.2%	4.0%

Table 6.21 Mean annualized repair cost.

	Design A: Code design	Design B: PBEE design	Design C: PBEE+ design
Building 1: Concrete core wall	\$326,000	\$336,000	\$282,000
Building 2: Concrete dual frame	\$323,000	\$269,000	\$269,000
Building 3: Steel BRB	\$206,000	\$157,000	\$141,000

Table 6.22 Net present value of insurance premiums.

	Building 1	Building 2	Building 3
Design A	\$8,390,000	\$8,330,000	\$5,300,000
Design B	\$8,650,000	\$6,930,000	\$4,050,000
Design C	\$7,260,000	\$6,930,000	\$3,630,000

Table 6.23 Total Cost = construction cost + net present value of insurance premiums.

	Building 1	Building 2	Building 3
Design A	\$149,000,000	\$157,000,000	\$346,000,000
Design B	\$149,000,000	\$180,000,000	\$333,000,000
Design C	\$150,000,000	\$180,000,000	\$337,000,000

Table 6.24 Ratio of Total Costs.

	Building 1	Building 2	Building 3
Design A / Design A	1.00	1.00	1.00
Design B / Design A	1.00	1.15	0.96
Design C / Design A	1.01	1.15	0.97

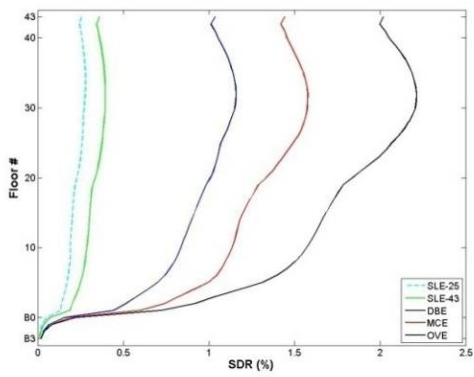

(a)

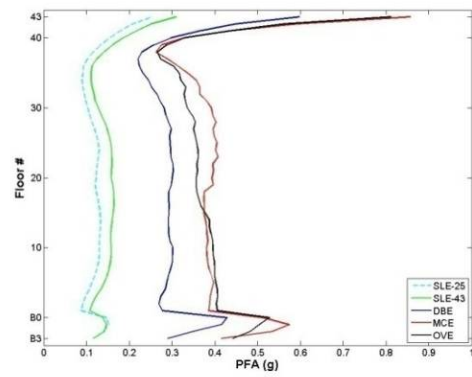

(b)

Figure 6.2 Distribution over height of (a) median peakSDR and (b) PFA of Building 2A at various performance levels.

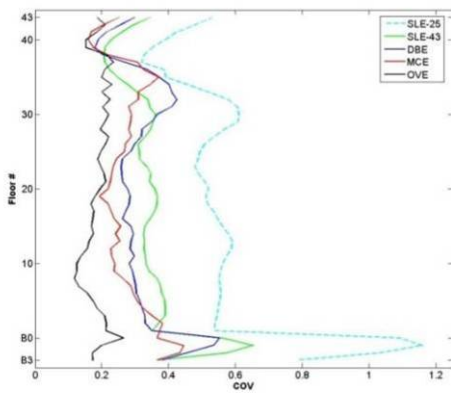

(a)

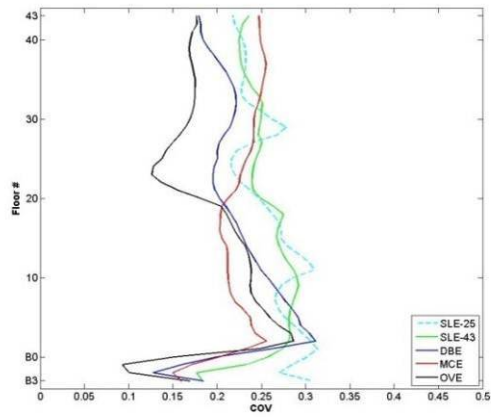

(b)

Figure 6.3 Distribution of standard deviation of logarithm of (a) peak SDR and (b) PFA of Building 2A at different performance levels.

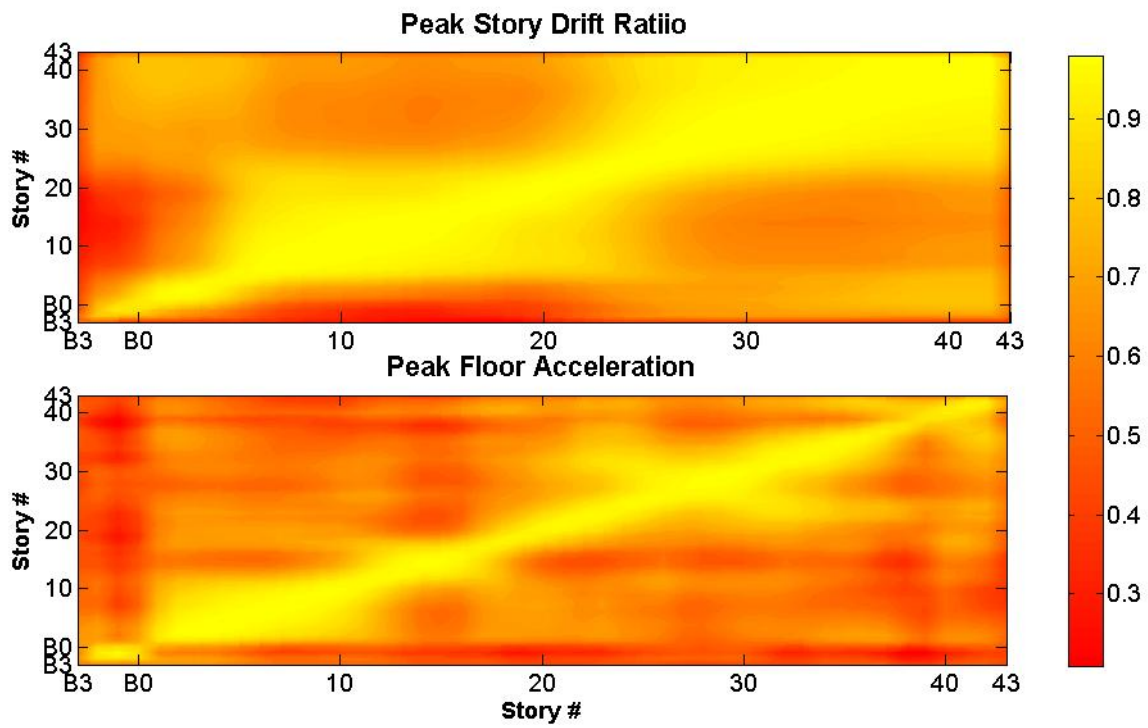
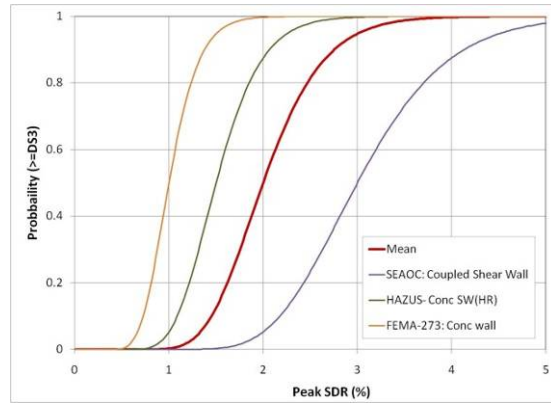
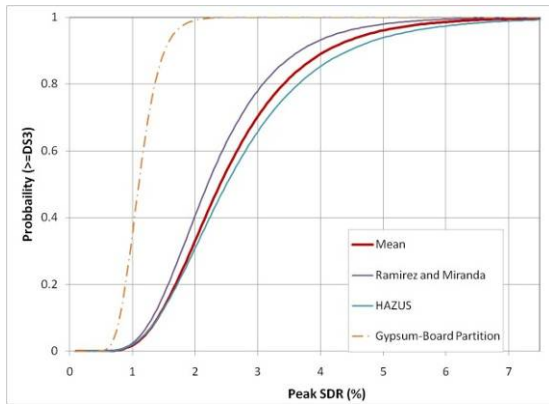

Figure 6.4 Correlation of peak SDR and PFA of Building 2A at different levels at MCE ground motion.



(a)



(b)

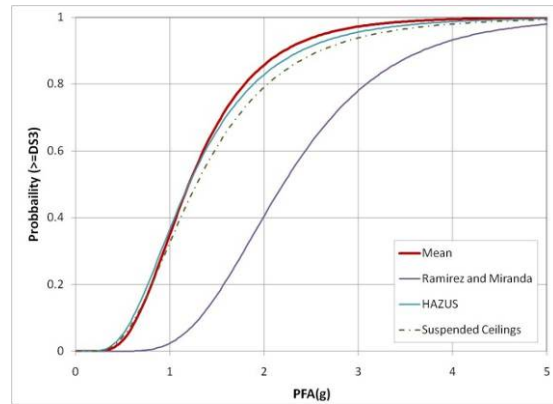

(c)

Figure 6.5 Mean fragility functions of different subsystems of buildings. Additionally some important component fragility functions are shown illustrating the relativity of the individual components; (a) extensive damage in dual-system structural subsystem; (b) extensive damage in nonstructural drift-sensitive subsystem; and (c) extensive damage in nonstructural acceleration-sensitive subsystem.

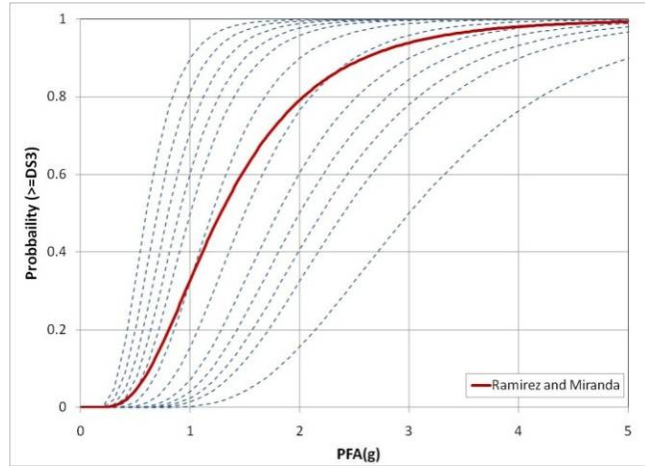

Figure 6.6 Fragility functions for suspended ceilings as developed by Aslani and Miranda [2005] and those defined in ATC-58 for different sizes and supports.

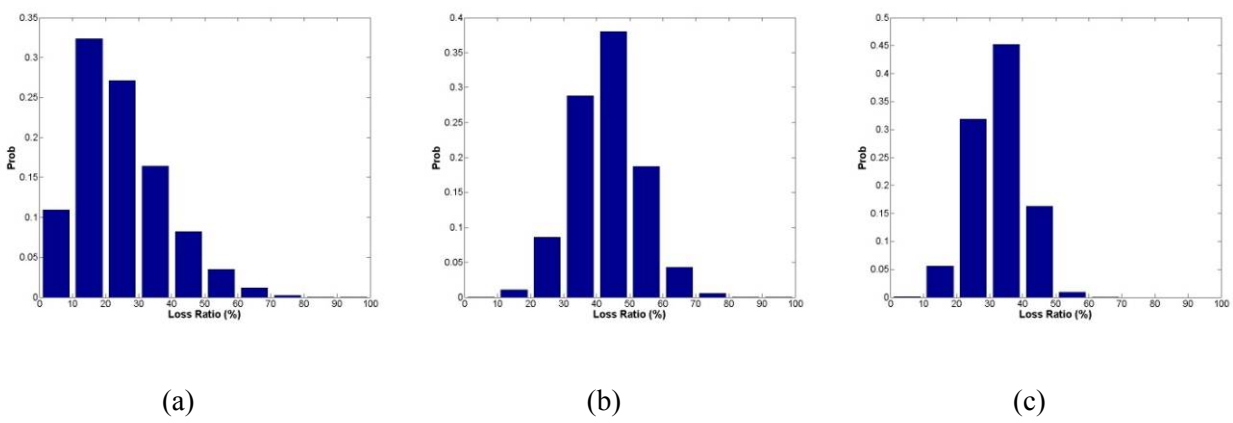

Figure 6.7 Distribution of normalized cost of different subsystems of buildings: (a) structure; (b) non-structural drift; and (c) non-structural acceleration.

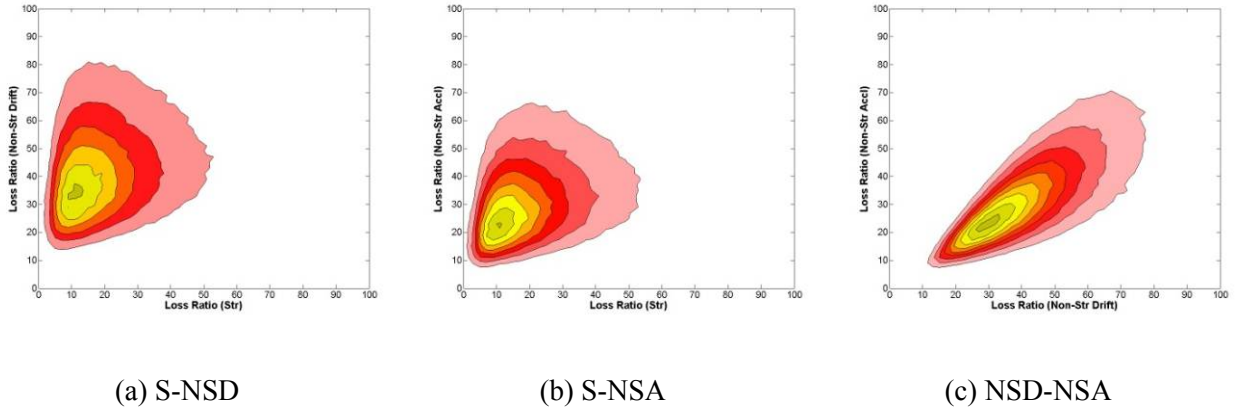

Figure 6.8 Contour of joint probability mass function of the normalized cost of structural (S), nonstructural drift-sensitive (NSD), and nonstructural acceleration-sensitive (NSA) subsystem of buildings.

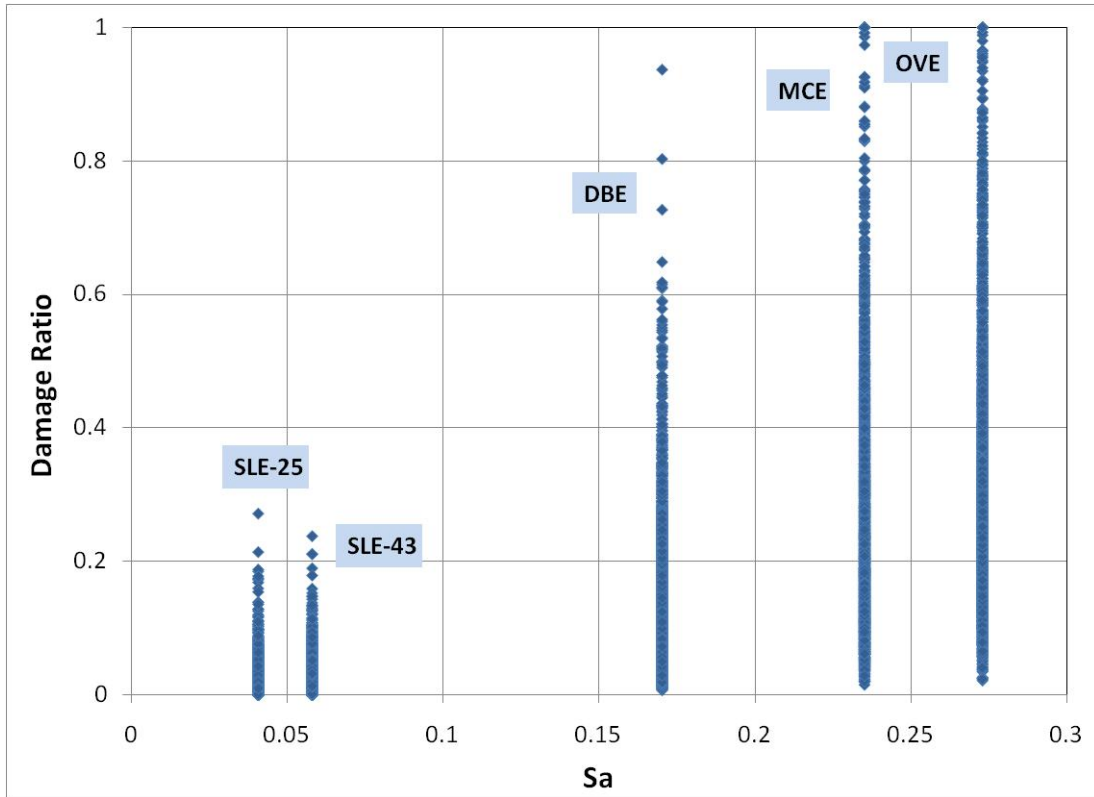

Figure 6.9 Mean and the distribution of loss ratio of Building 2A at the five different performance levels as obtained from simulation.

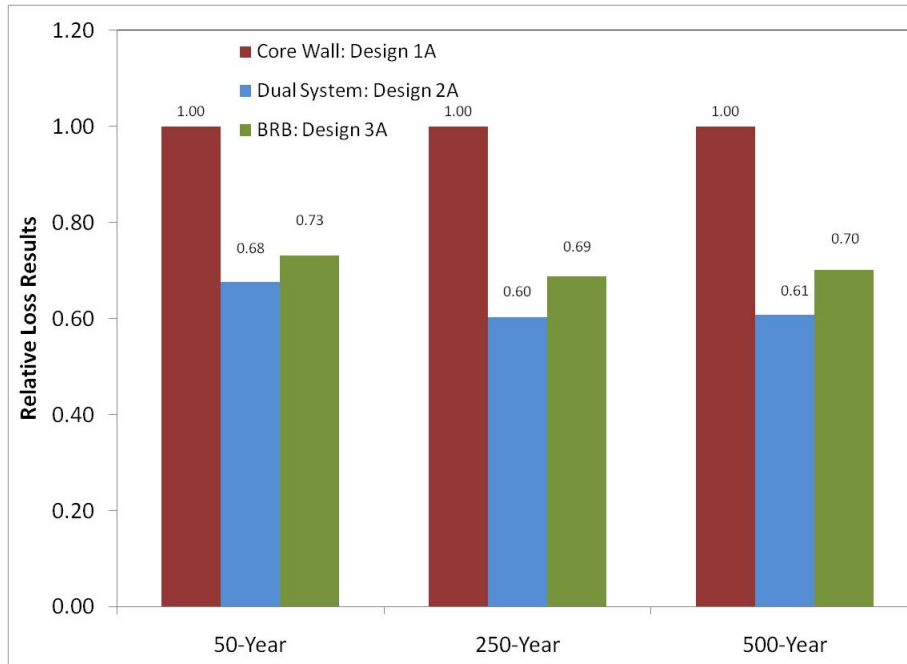

Figure 6.10 Loss results of different code-designed buildings relative to the code-designed core wall building at different return periods.

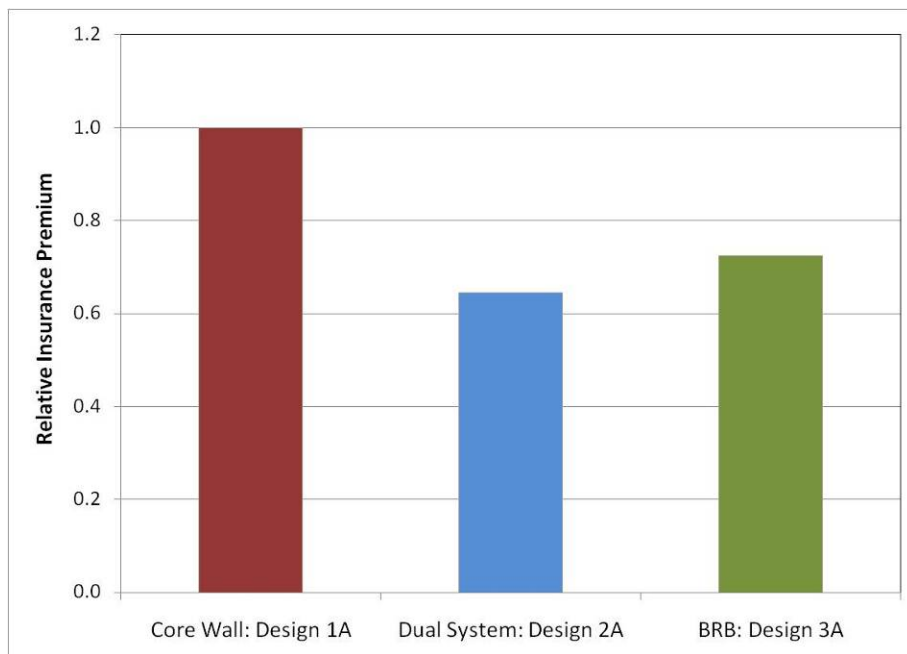

Figure 6.11 Ratio of pure premium (average annual loss) of different code-designed structures to code-designed core wall structure.

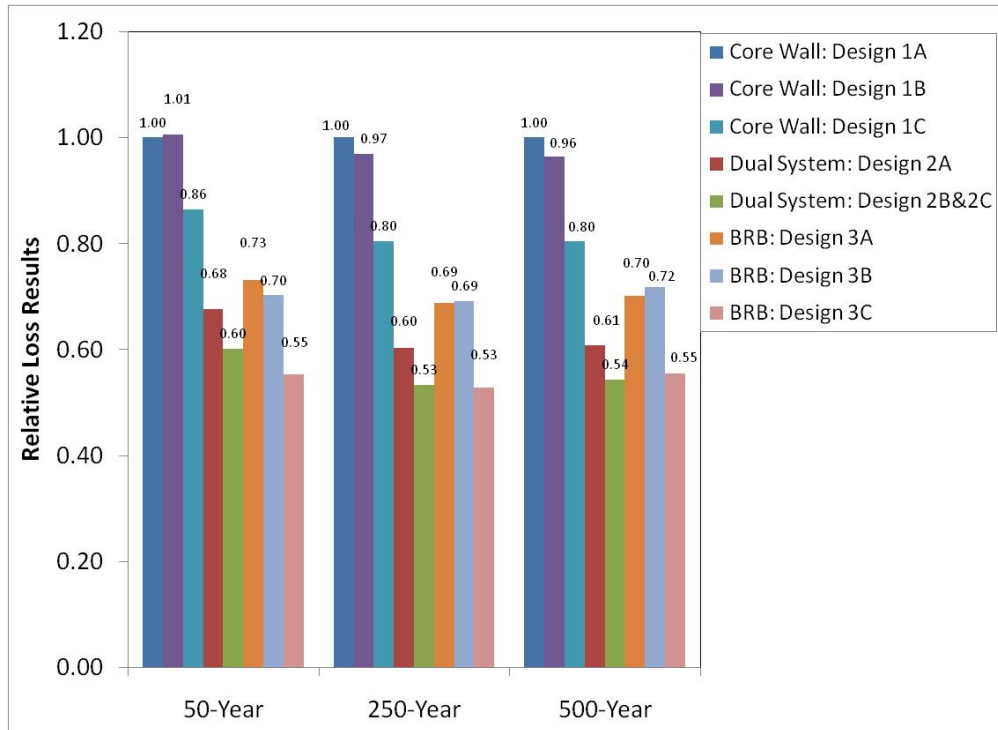

Figure 6.12 Ratio of loss ratios of all the buildings at different return periods to the code-designed core-wall building.

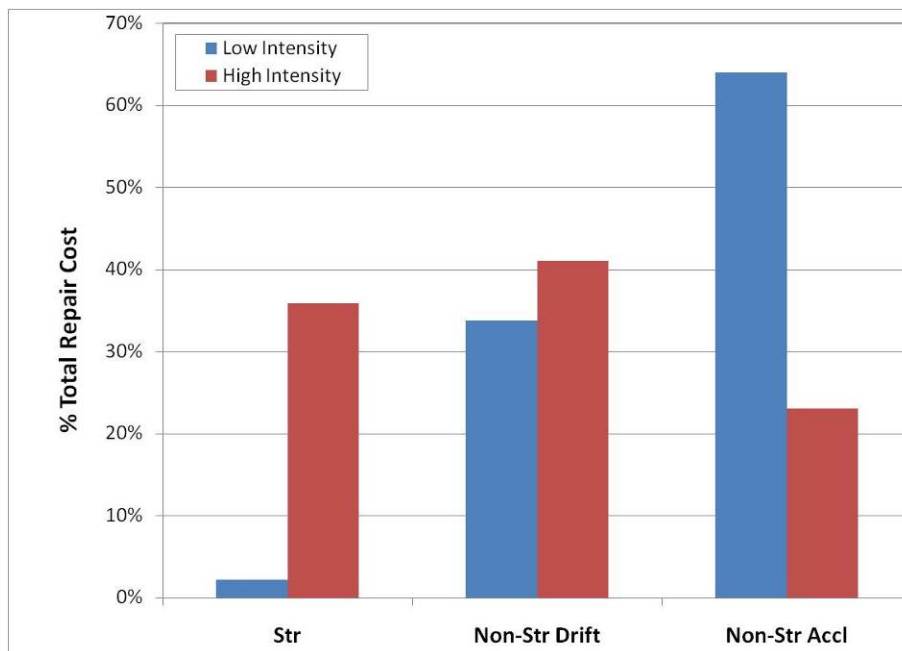

Figure 6.13 Contributions to repair cost of different subsystems of dual-system building (Building 2A) at the SLE-43 and MCE performance levels.(i.e., at the low and high intensities of ground motion).

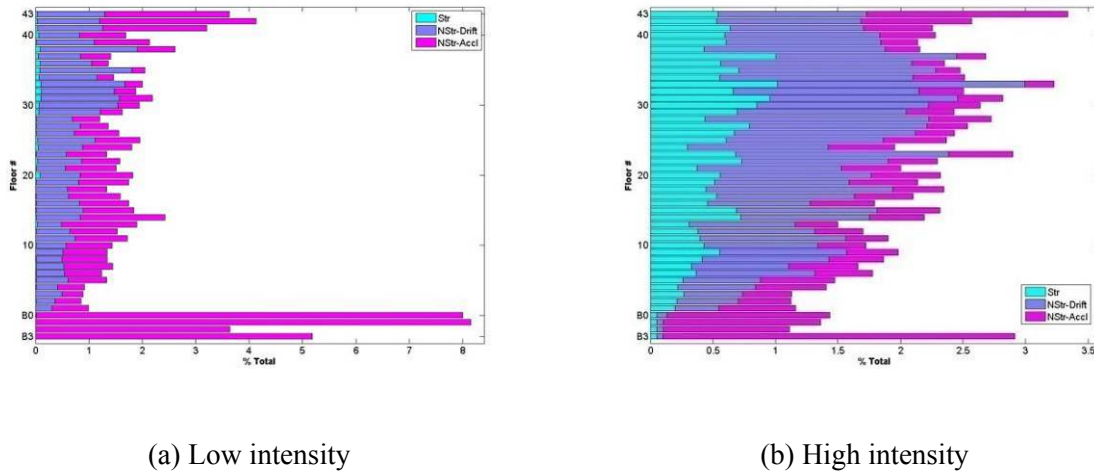

Figure 6.14 Distribution of repair cost over the height of Building 2A at the SLE-43 and MCE performance levels.

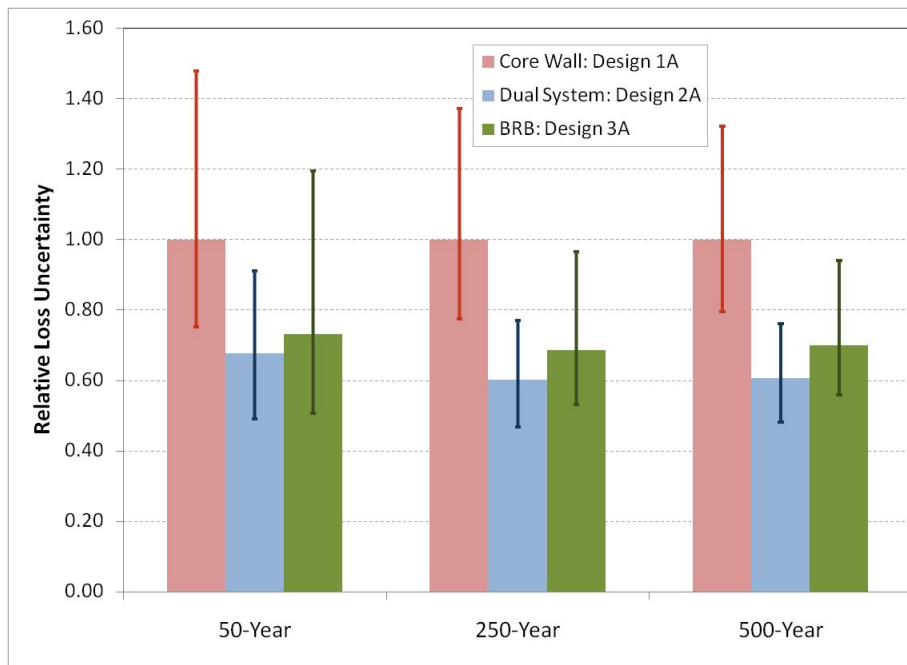

Figure 6.15 Epistemic uncertainty in the loss results of various code-designed buildings relative to code-designed core-wall building due to 1-sigma (epistemic) uncertainty (or between 16% to 84% uncertainty) in the vulnerability functions.

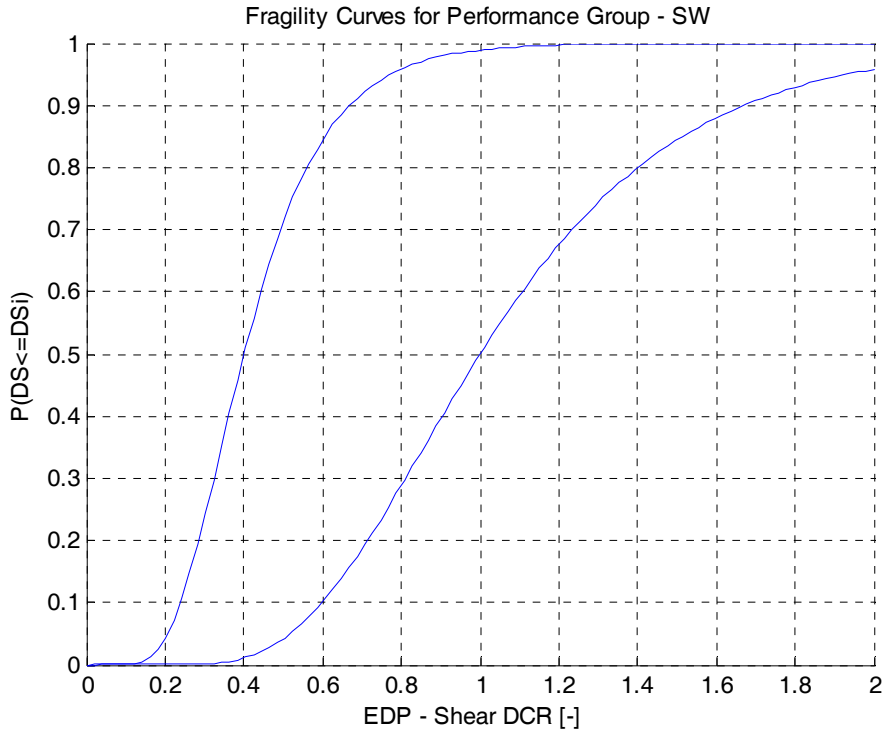

Figure 6.16 Fragility curves for SW.

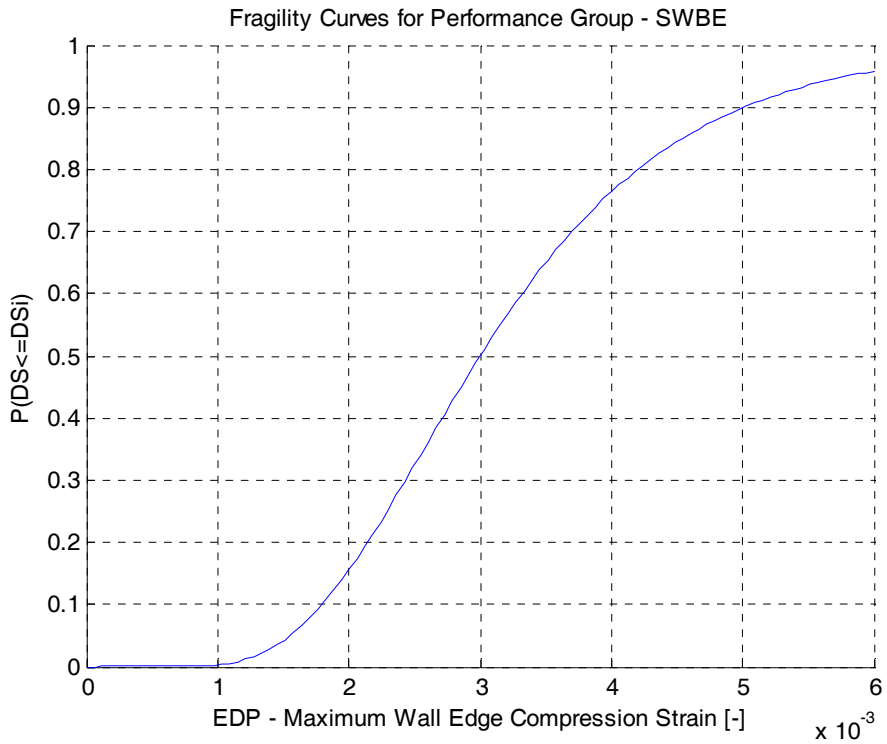

Figure 6.17 Fragility curve for SWBE.

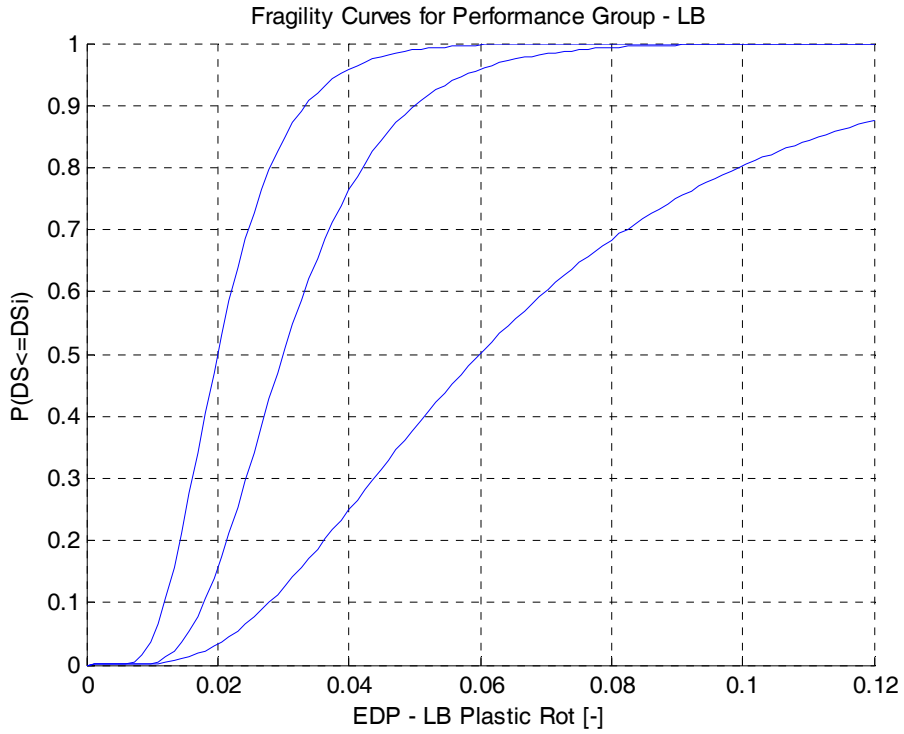

Figure 6.18 Fragility curves for LB.

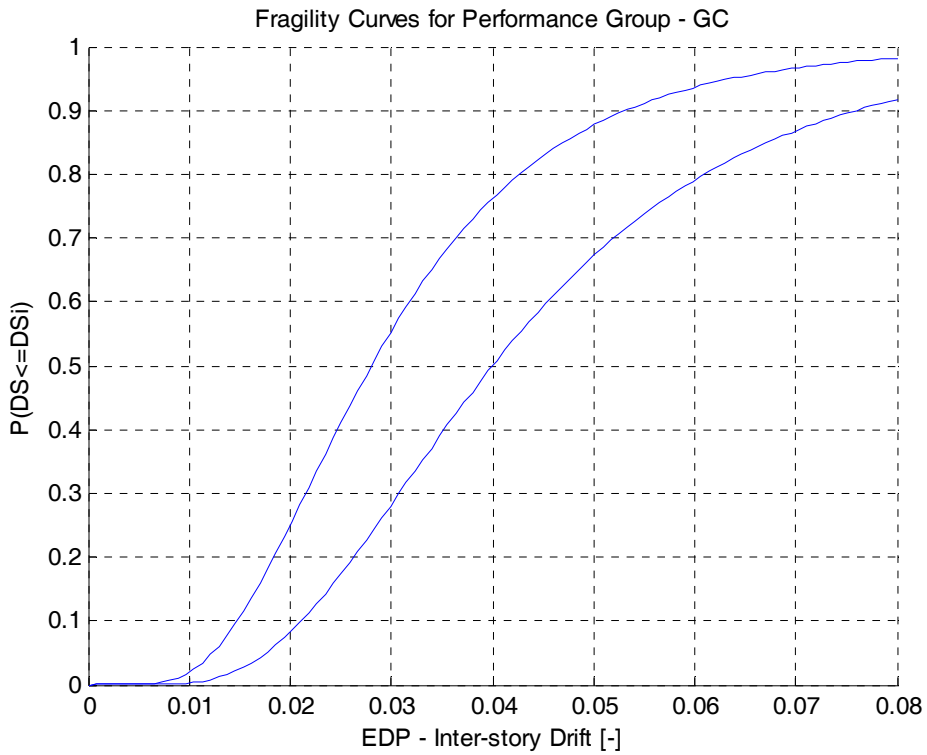

Figure 6.19 Fragility curves for GC.

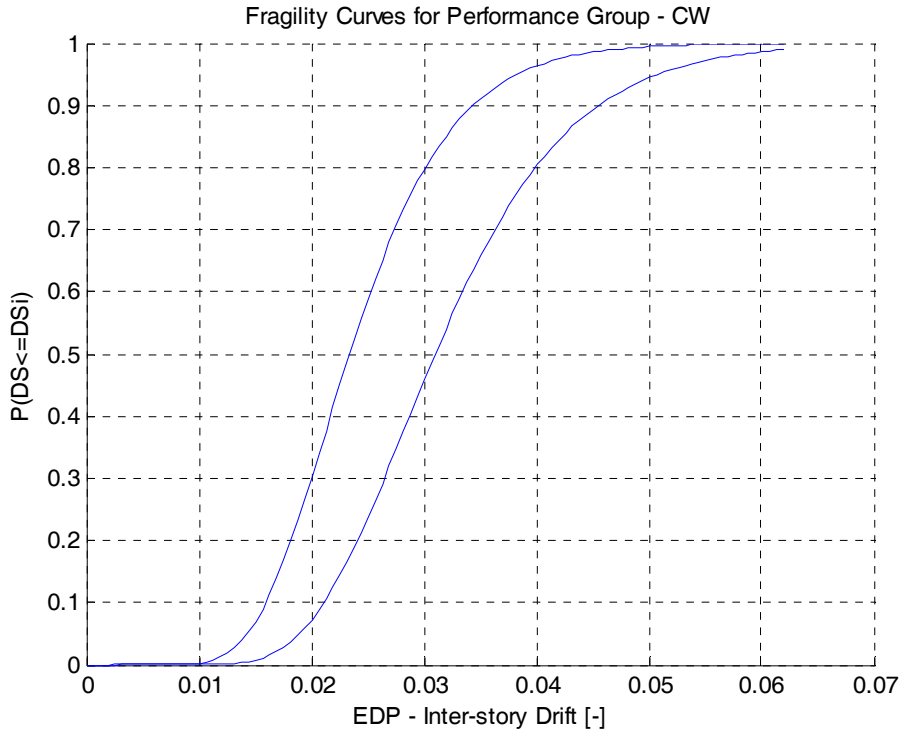

Figure 6.20 Fragility curves for CW.

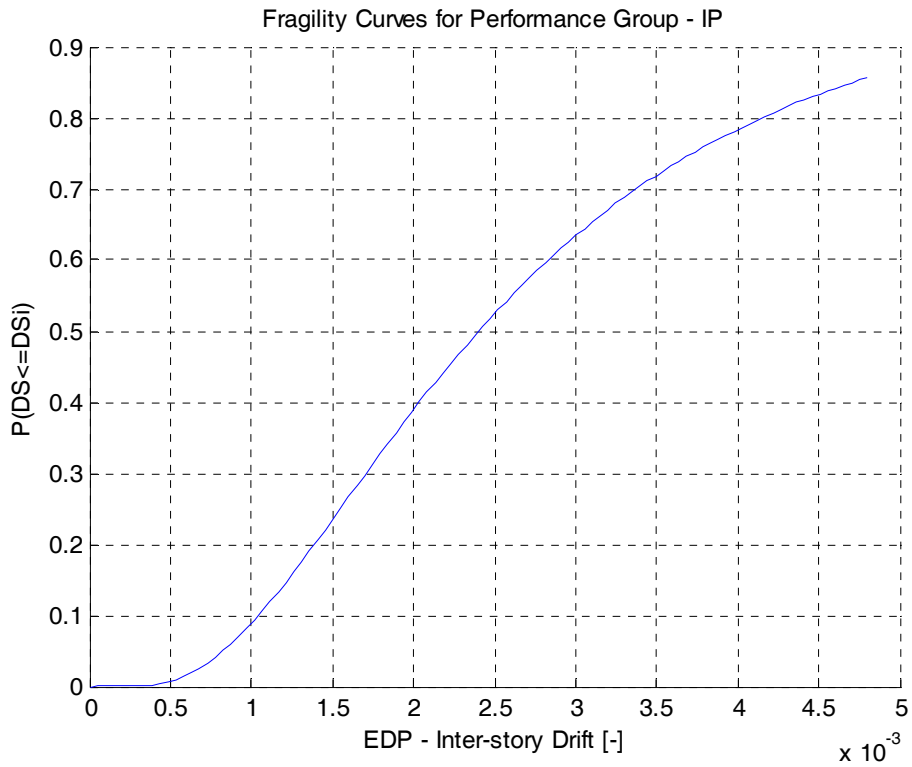

Figure 6.21 Fragility curve for IP.

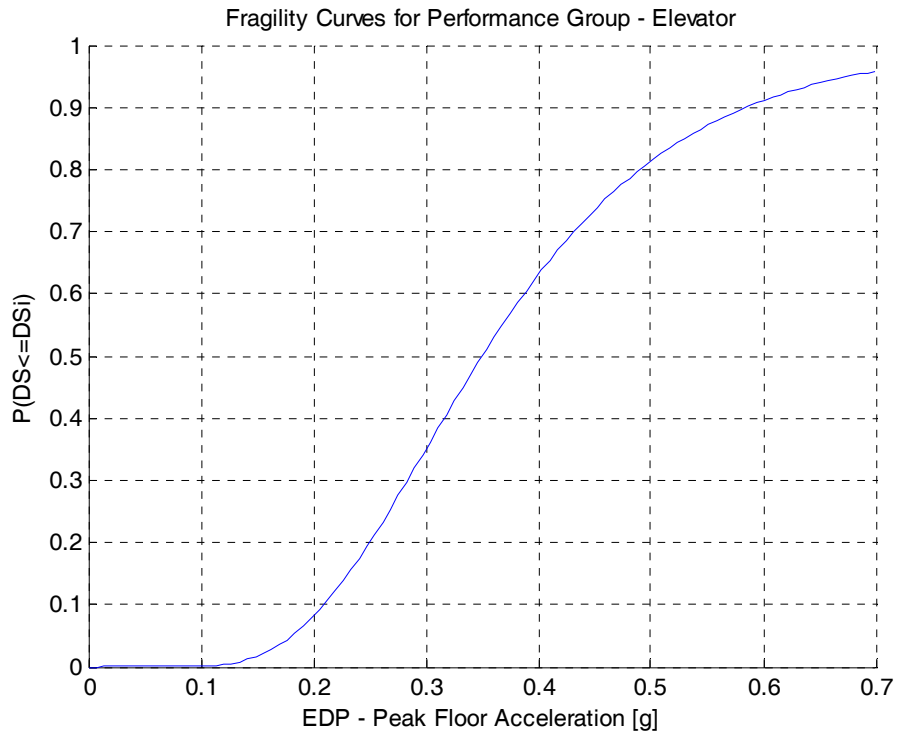

Figure 6.22 Fragility curve for elevator.

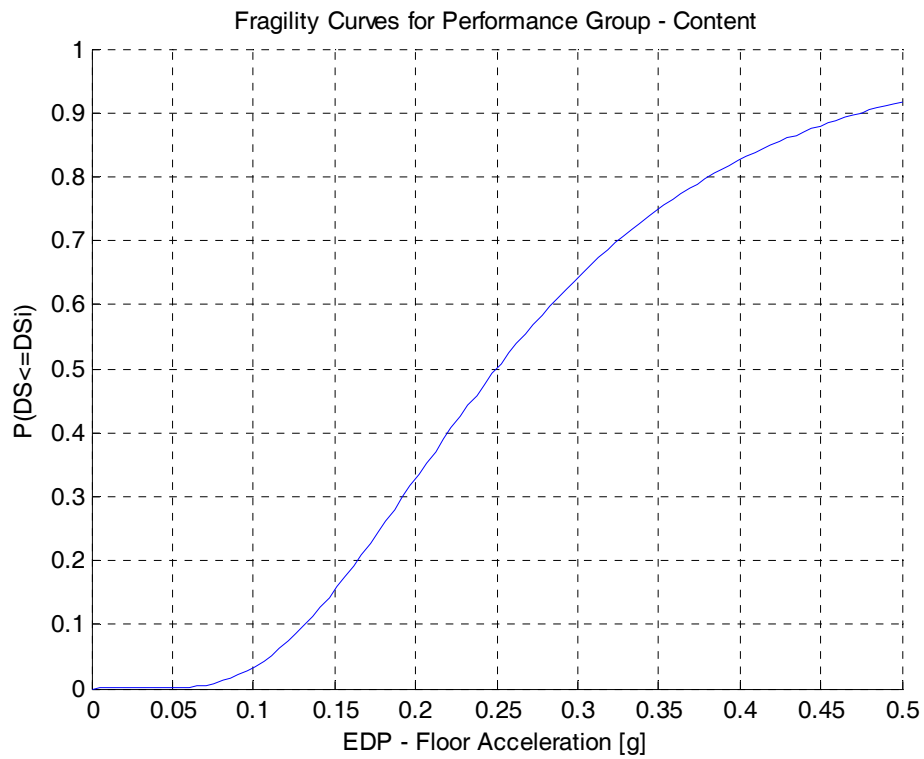

Figure 6.23 Fragility curve for contents.

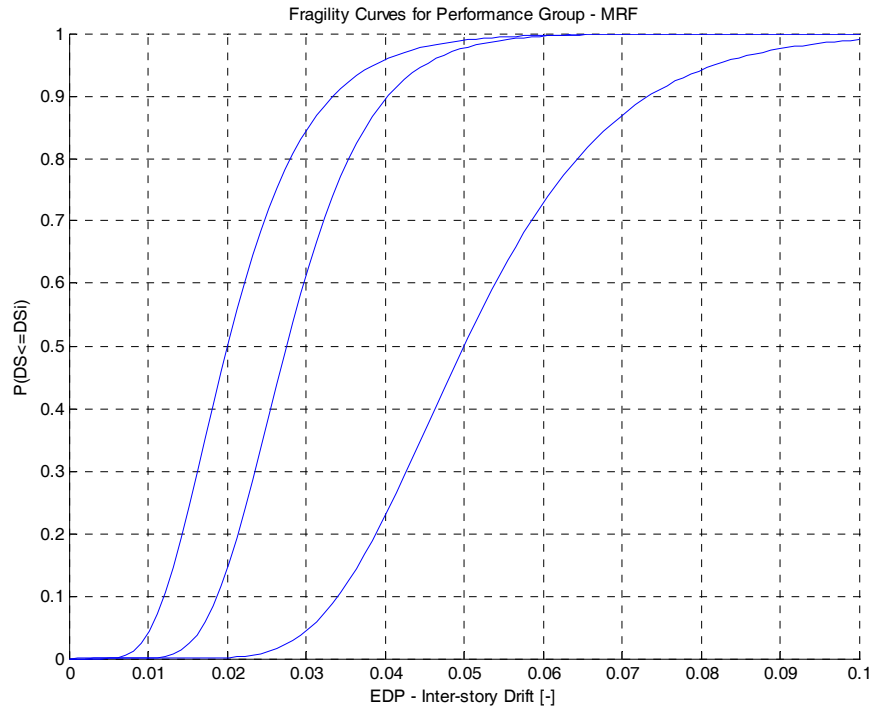

Figure 6.24 Fragility curves for MRF

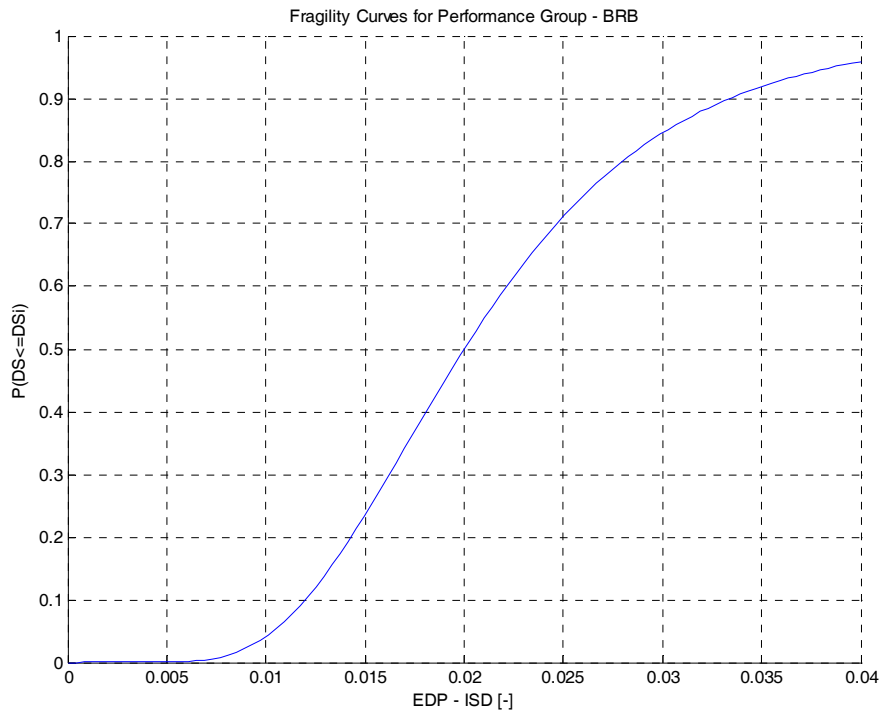

Figure 6.25 Fragility curves for the steel BRBs.

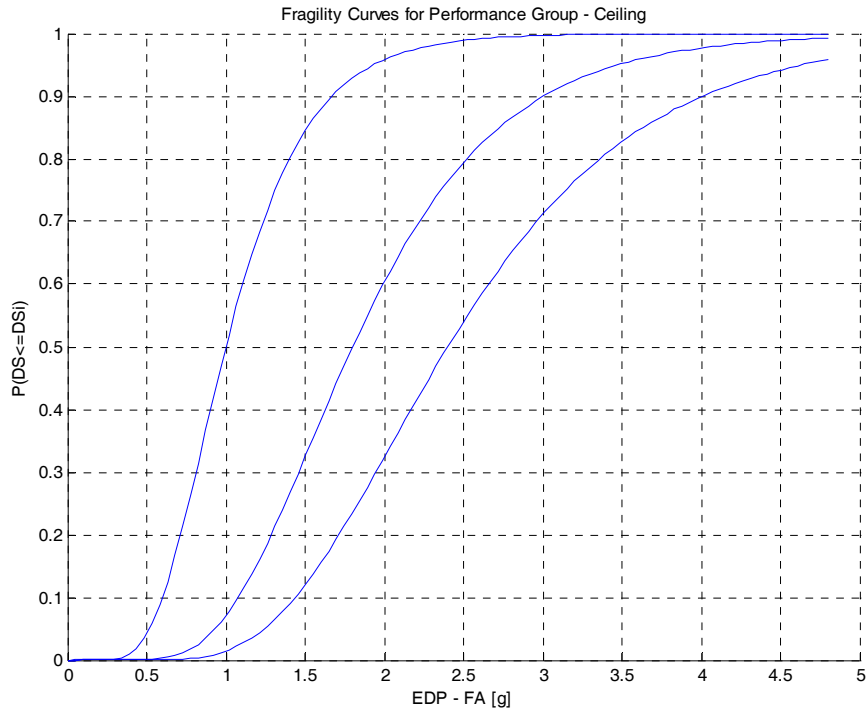

Figure 6.26 Fragility curves for the ceiling in the steel building.

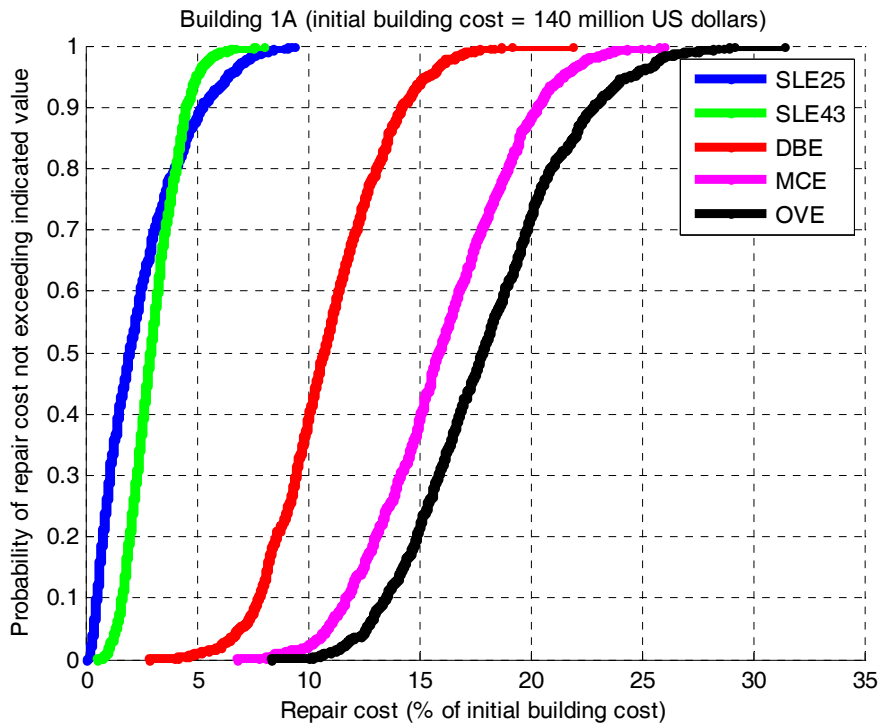

Figure 6.27 Repair cost distribution of Building 1A.

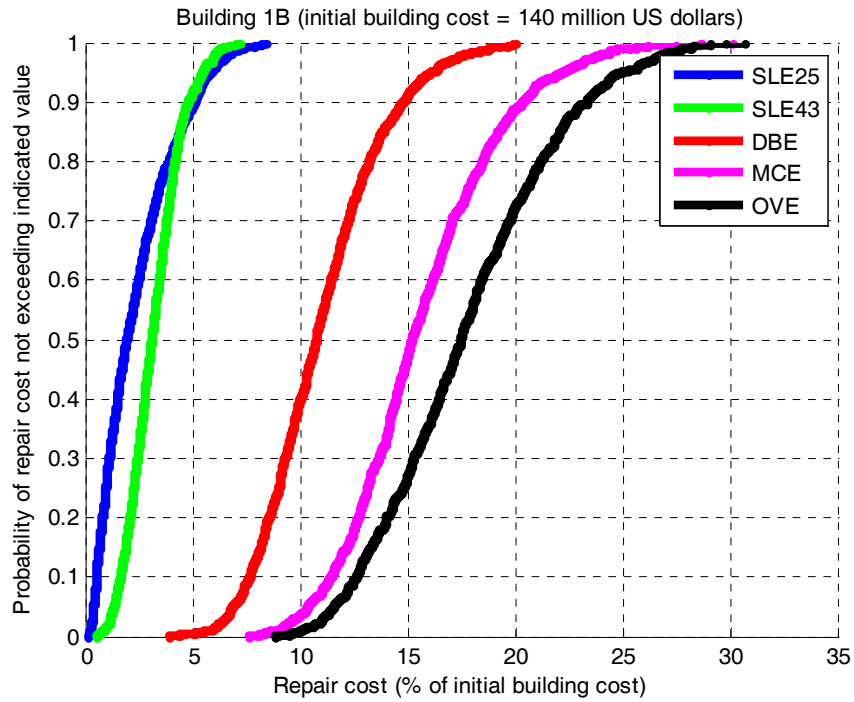

Figure 6.28 Repair cost distribution of Building 1B.

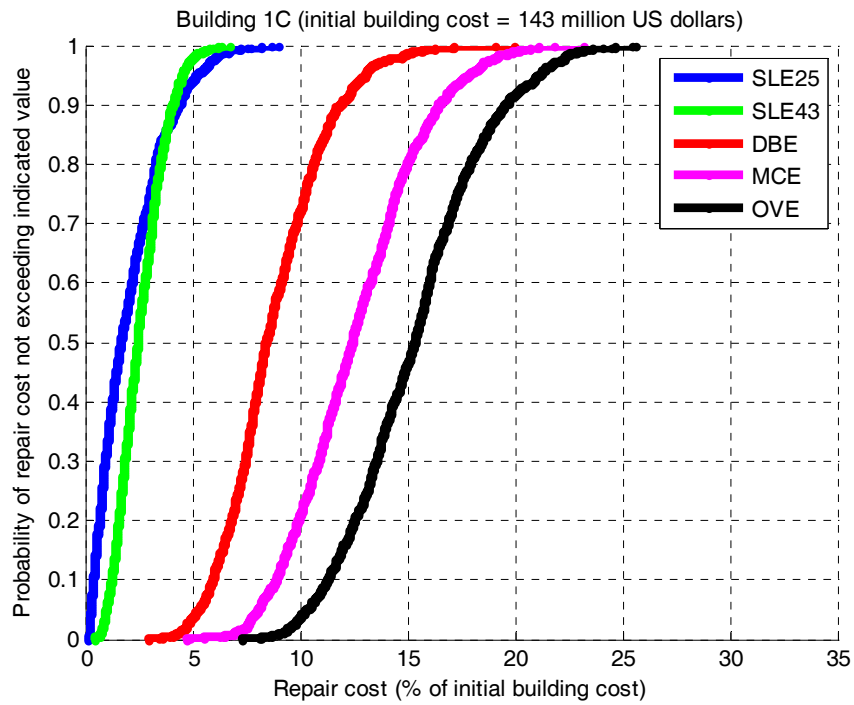

Figure 6.29 Repair cost distribution of Building 1C.

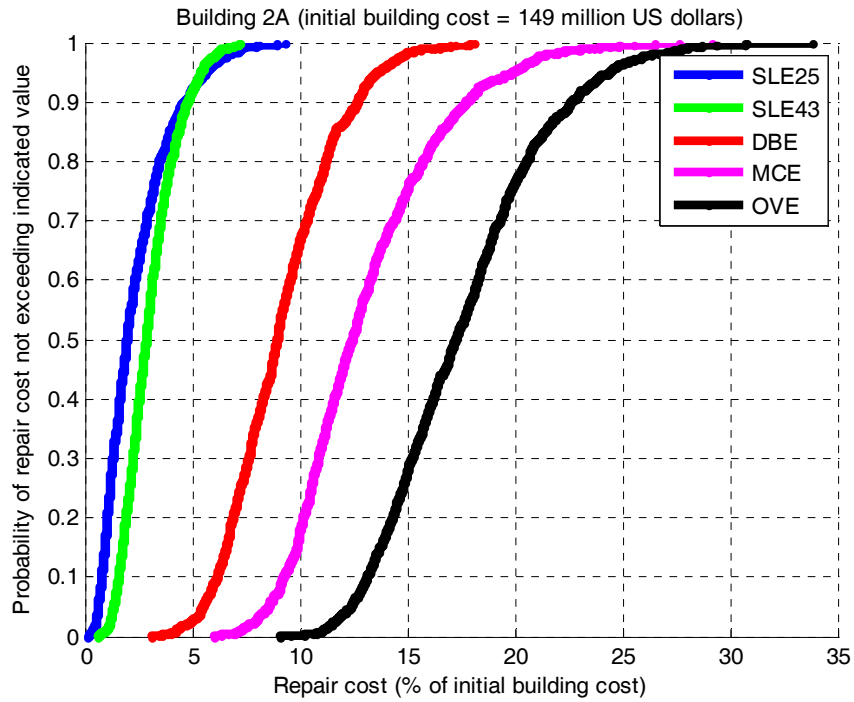

Figure 6.30 Repair cost distribution of Building 2A.

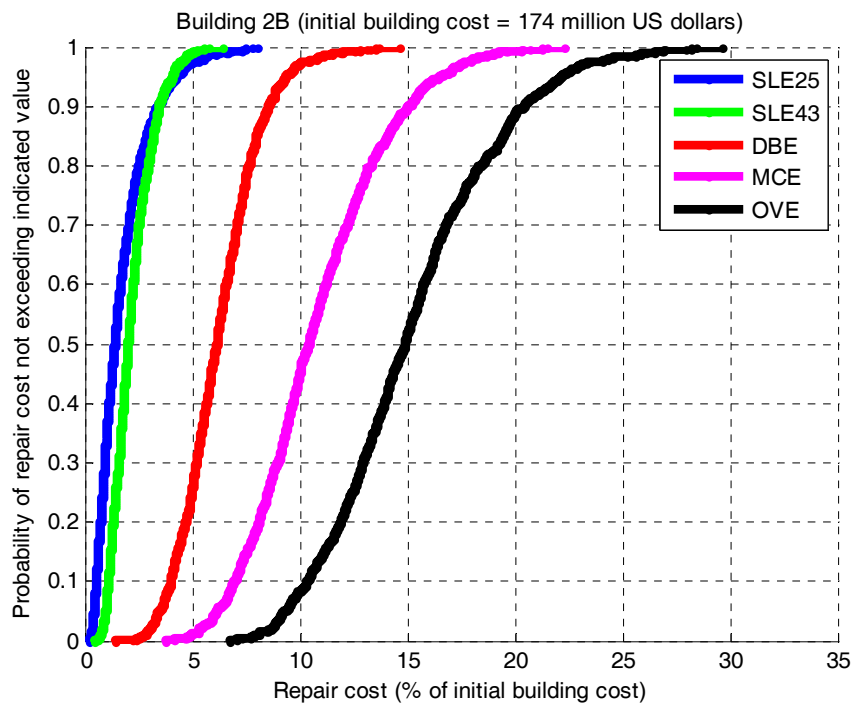

Figure 6.31 Repair cost distribution of Building 2B/2C.

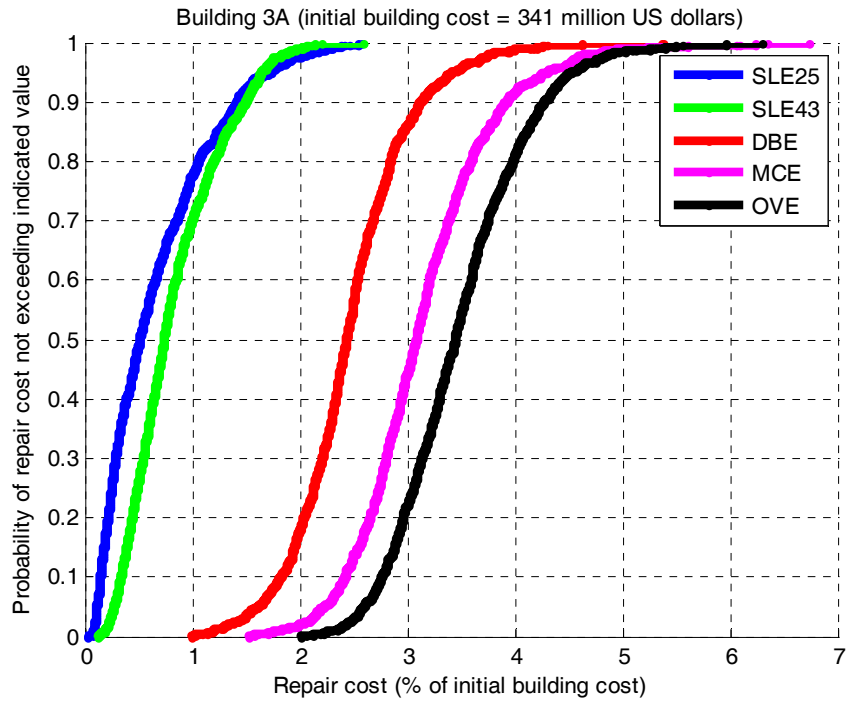

Figure 6.32 Repair cost distribution of Building 3A.

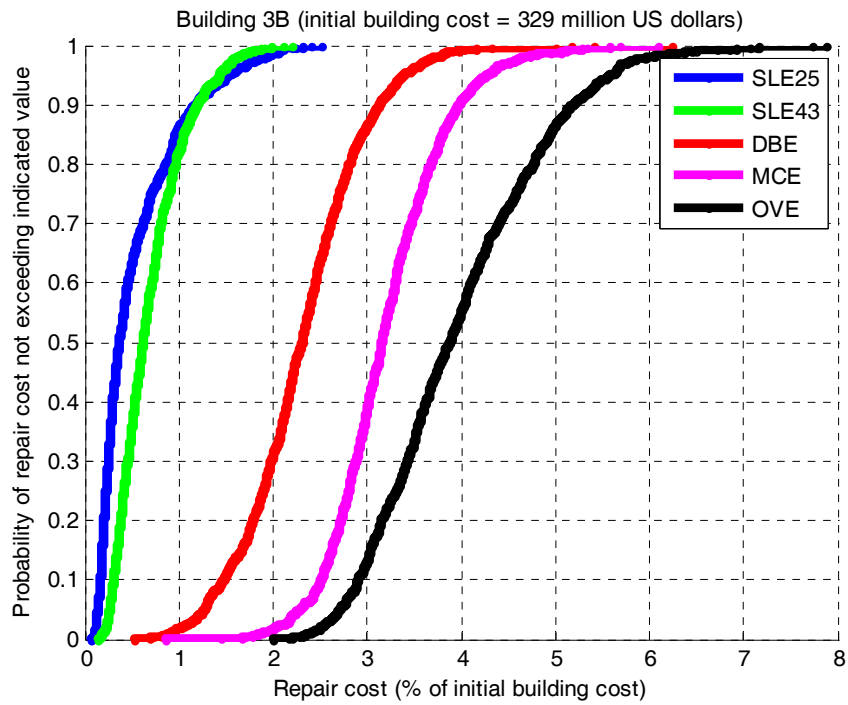

Figure 6.33 Repair cost distribution of Building 3B.

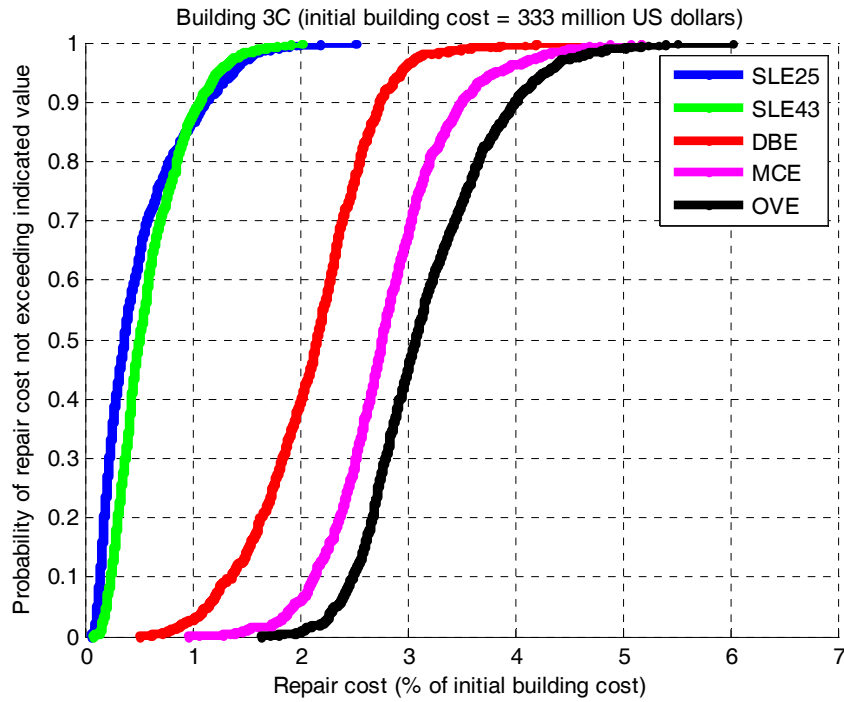

Figure 6.34 Repair cost distribution of Building 3C.

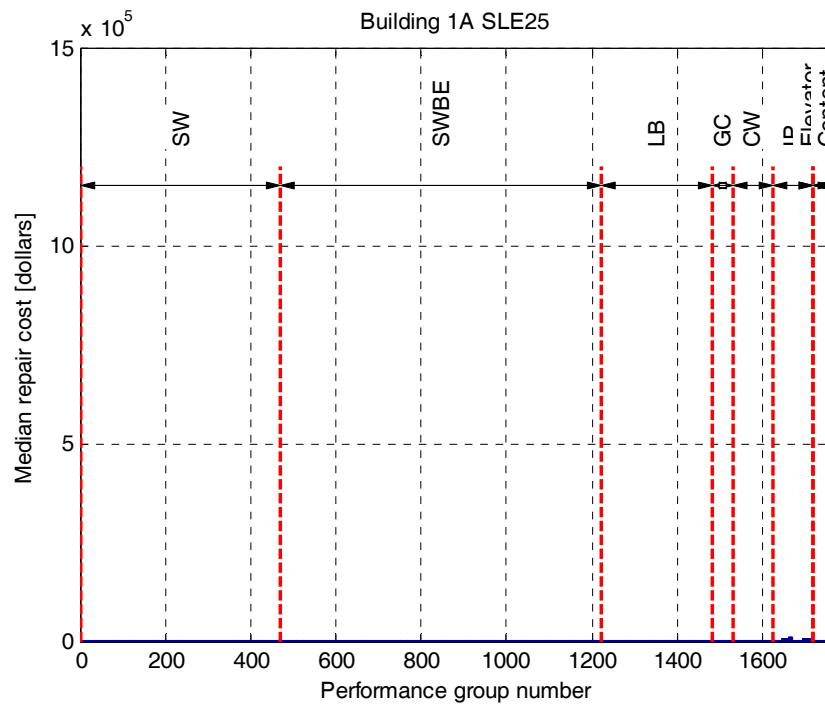

Figure 6.35 Deaggregation of median repair cost for Building 1A at SLE25 hazard level.

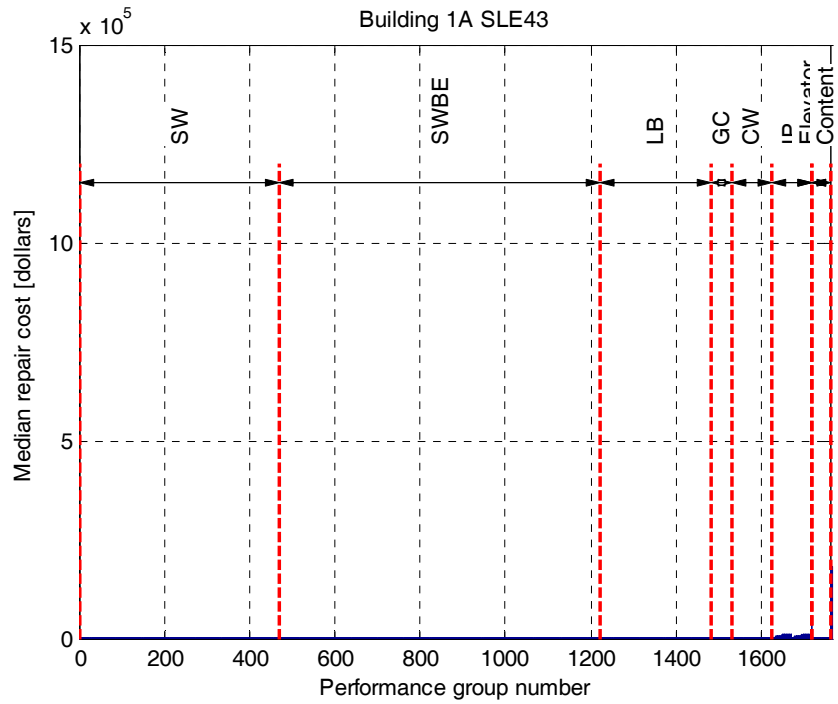

Figure 6.36 Deaggregation of median repair cost for Building 1A at SLE43 hazard level.

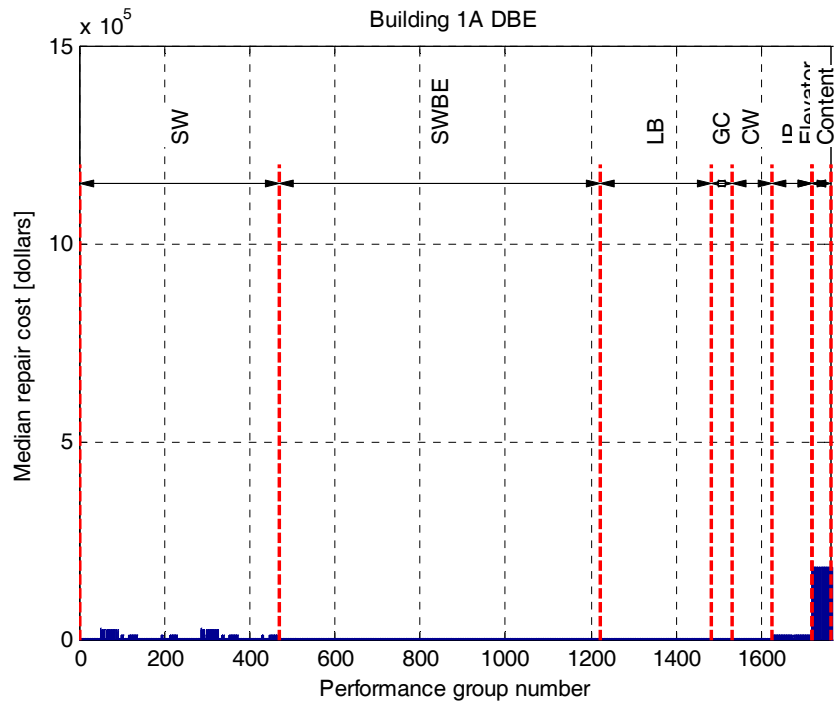

Figure 6.37 Deaggregation of median repair cost for Building 1A at DBE hazard level.

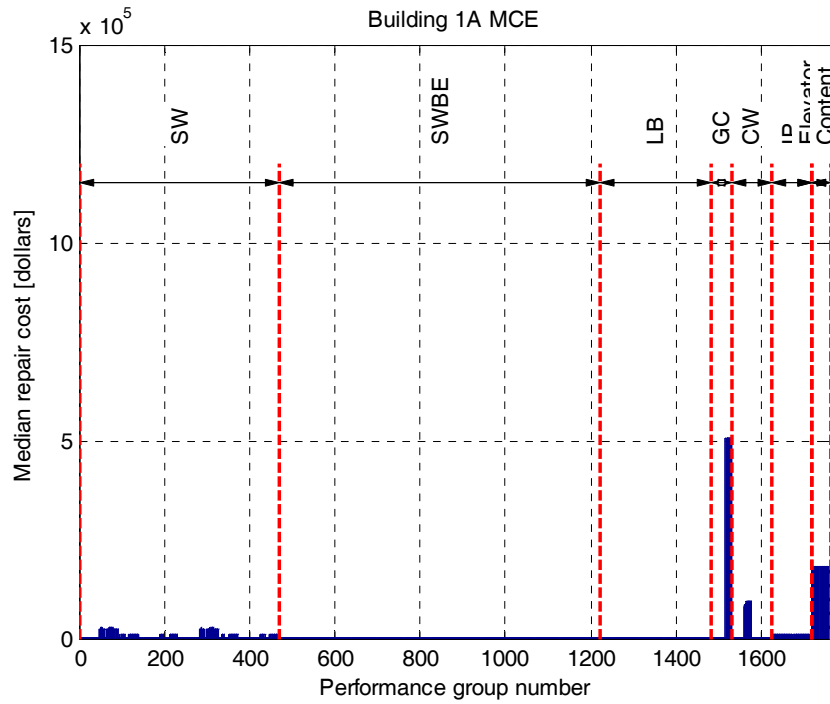

Figure 6.38 Deaggregation of median repair cost for Building 1A at MCE hazard level.

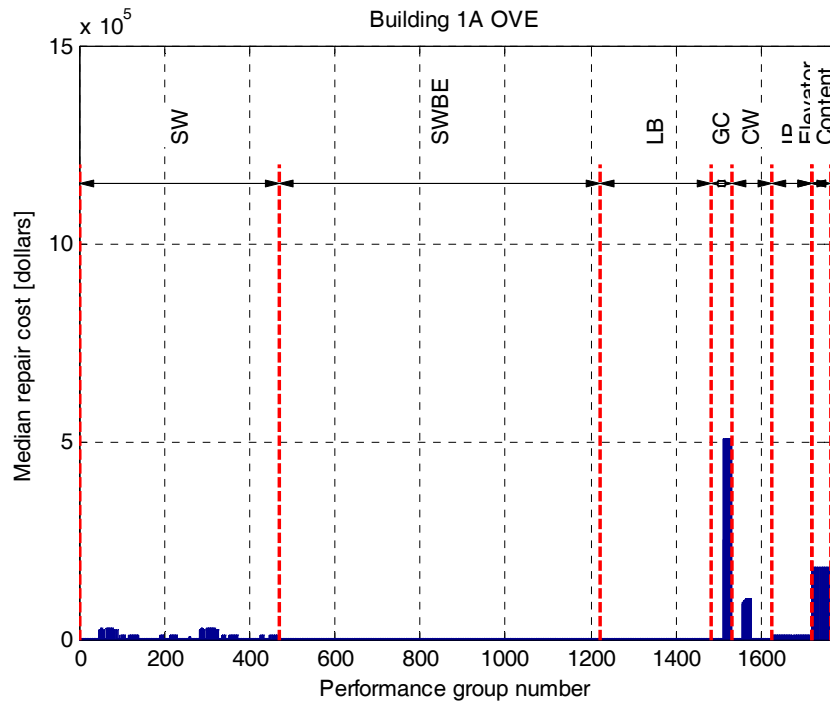

Figure 6.39 Deaggregation of median repair cost for Building 1A at OVE hazard level.

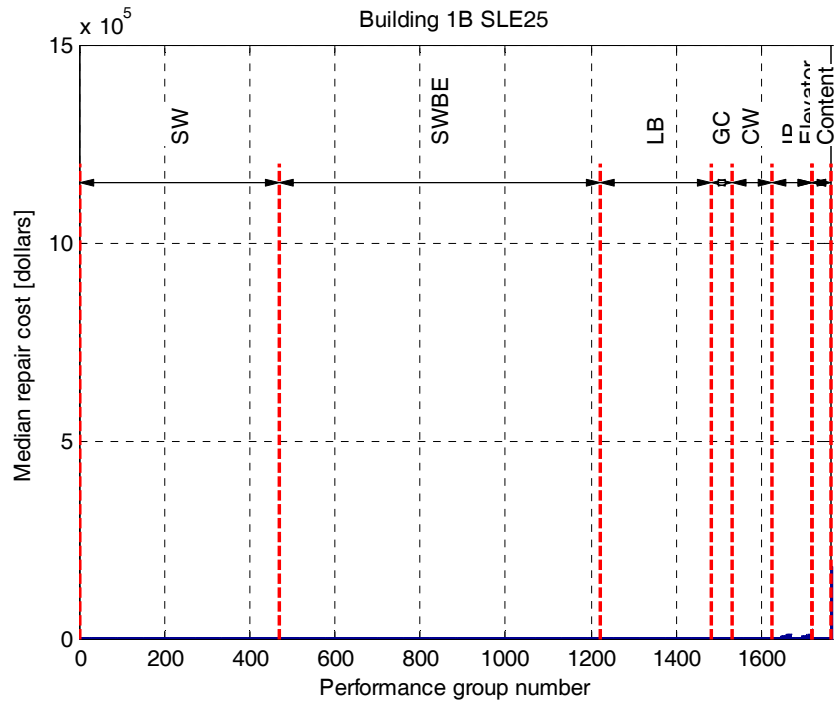

Figure 6.40 Deaggregation of median repair cost for Building 1B at SLE25 hazard level.

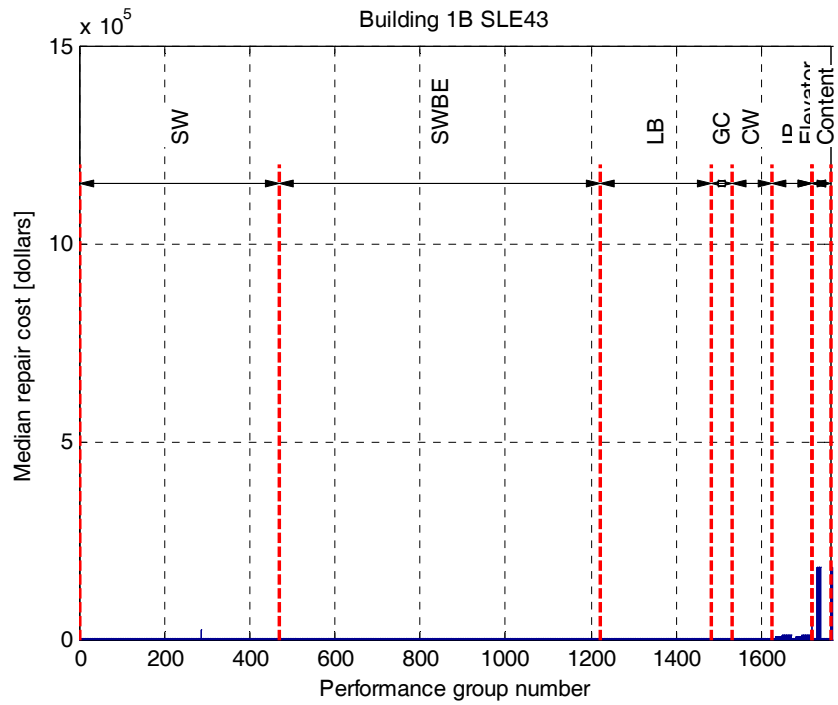

Figure 6.41 Deaggregation of median repair cost for Building 1B at SLE43 hazard level.

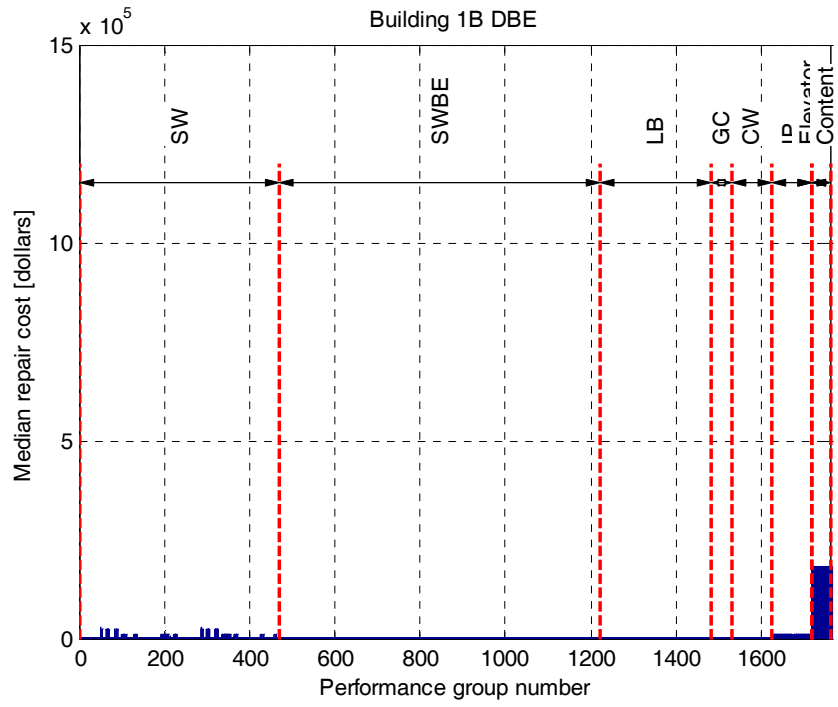

Figure 6.42 Deaggregation of median repair cost for Building 1B at DBE hazard level.

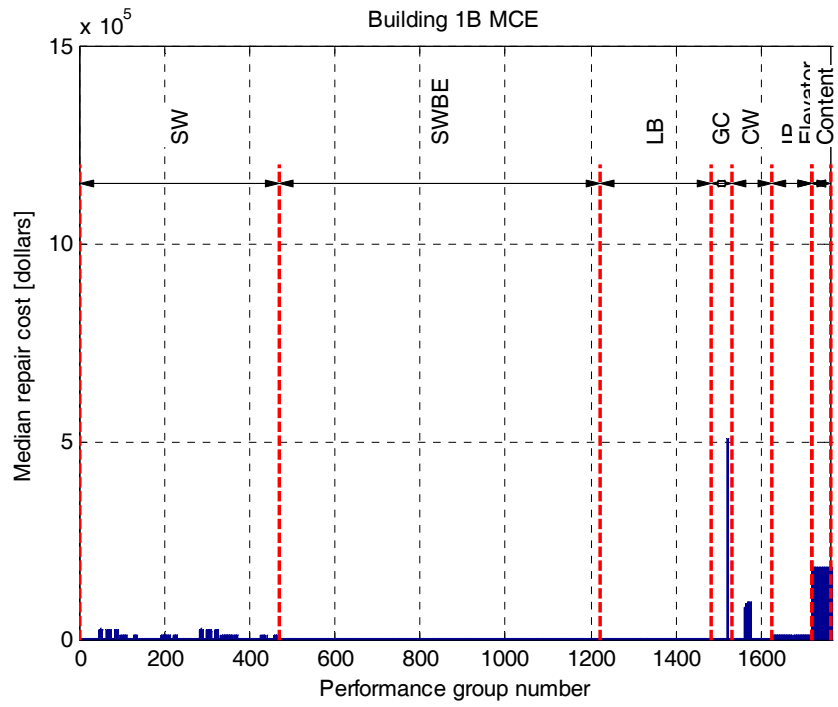

Figure 6.43 Deaggregation of median repair cost for Building 1B at MCE hazard level.

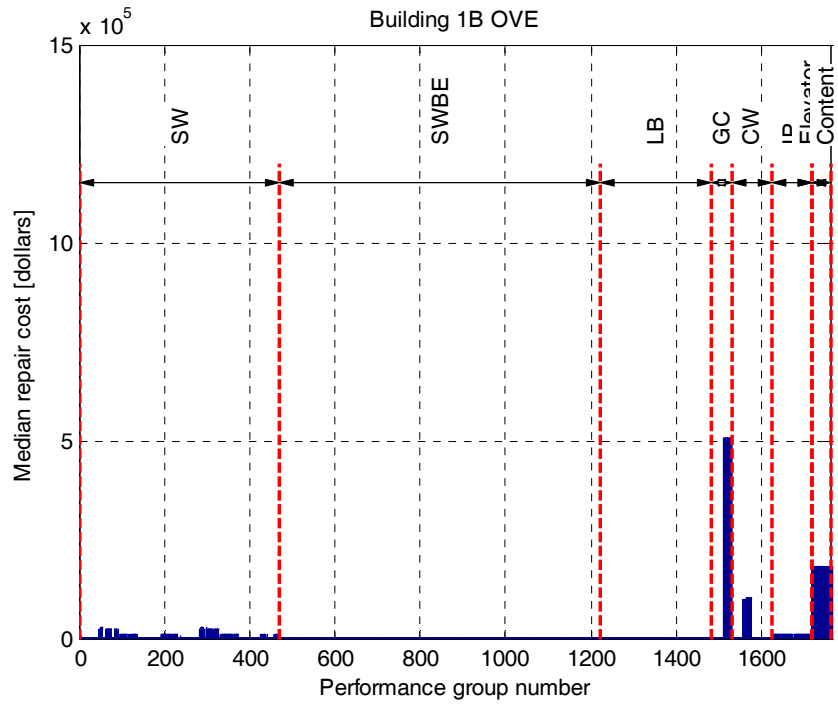

Figure 6.44 Deaggregation of median repair cost for Building 1B at OVE hazard level.

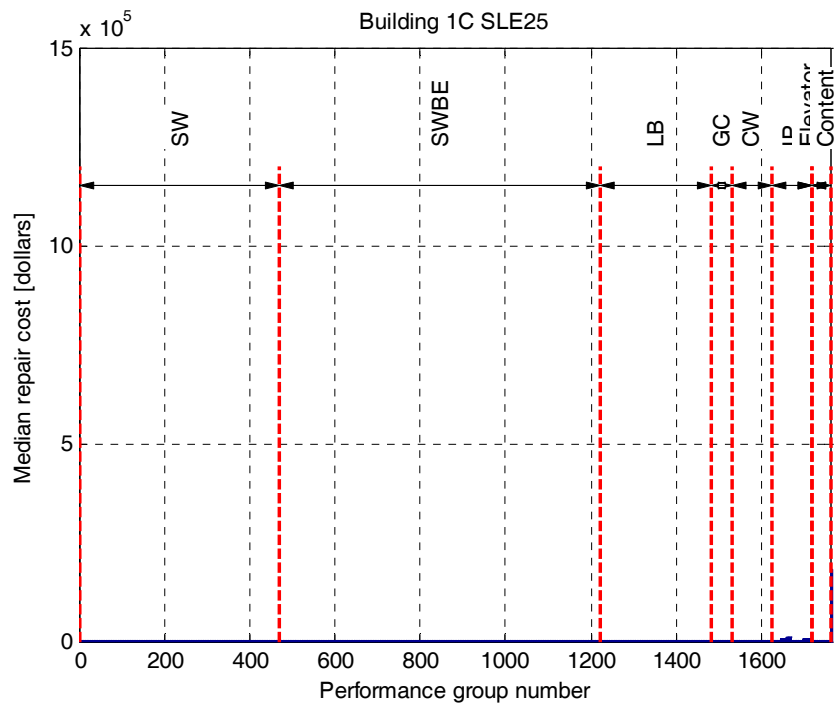

Figure 6.45 Deaggregation of median repair cost for Building 1C at SLE25 hazard level.

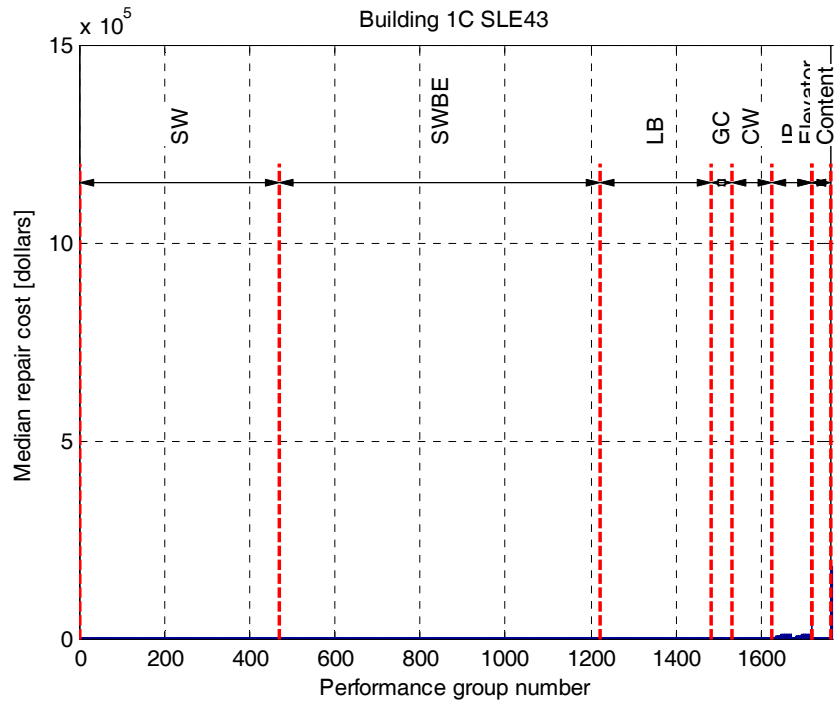

Figure 6.46 Deaggregation of median repair cost for Building 1C at SLE43 hazard level.

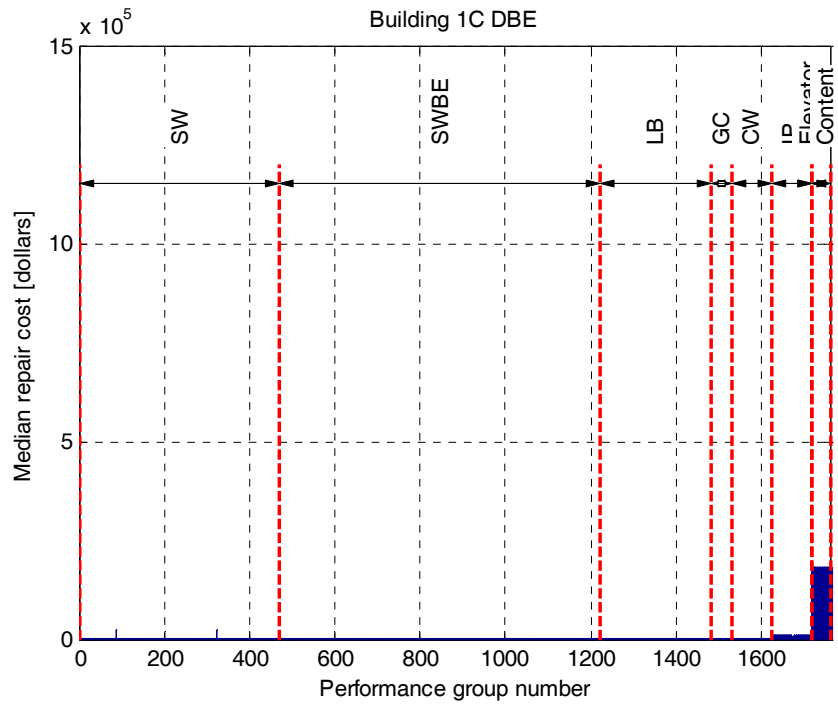

Figure 6.47 Deaggregation of median repair cost for Building 1C at DBE hazard level.

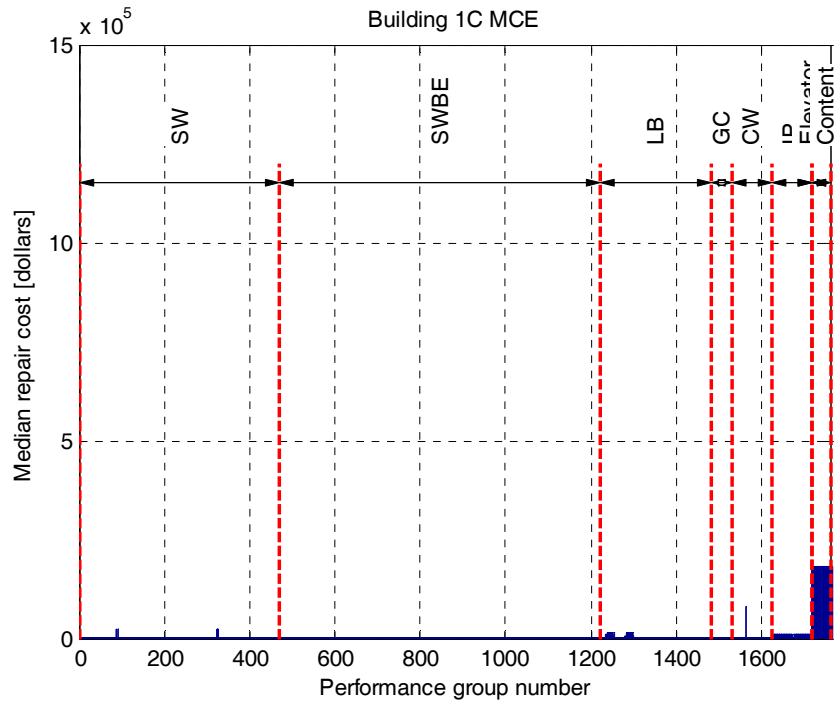

Figure 6.48 Deaggregation of median repair cost for Building 1C at MCE hazard level.

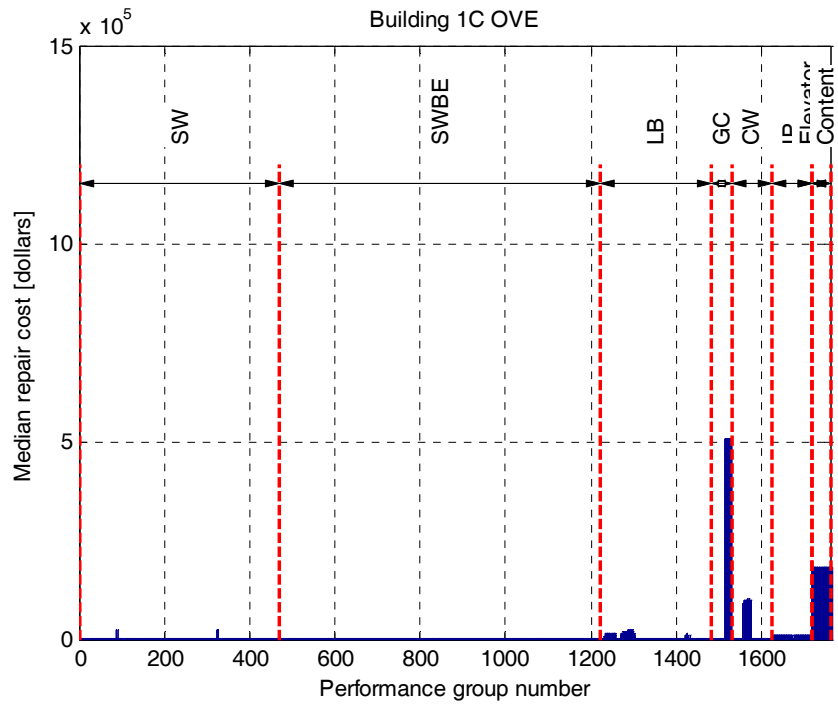

Figure 6.49 Deaggregation of median repair cost for Building 1C at OVE hazard level.

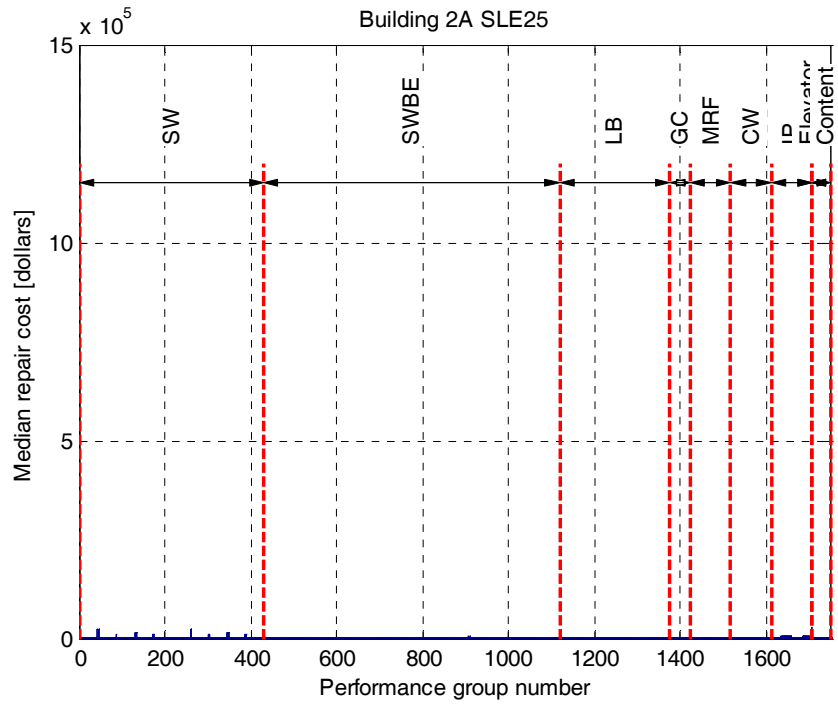

Figure 6.50 Deaggregation of median repair cost for Building 2A at SLE25 hazard level.

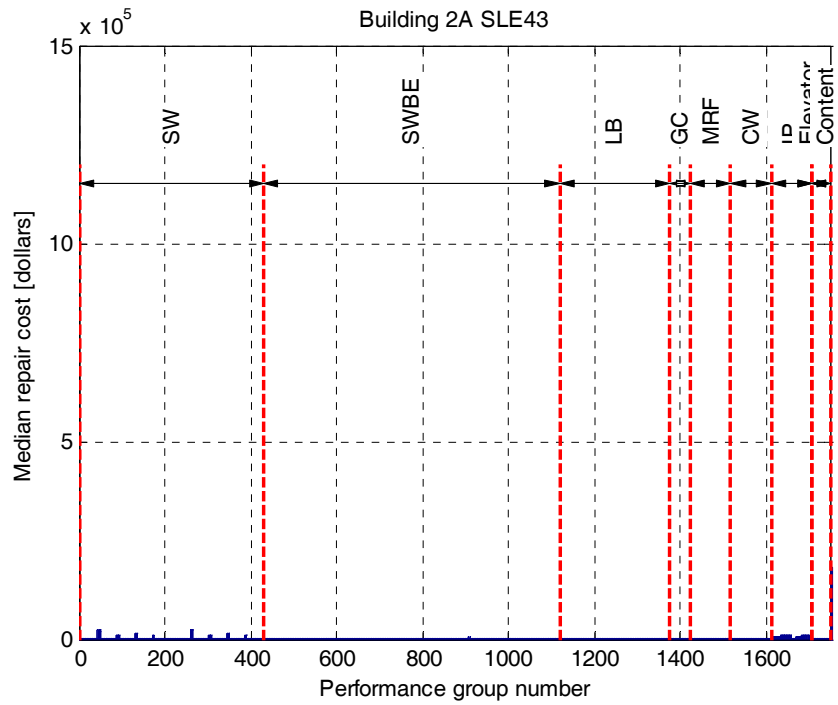

Figure 6.51 Deaggregation of median repair cost for Building 2A at SLE43 hazard level.

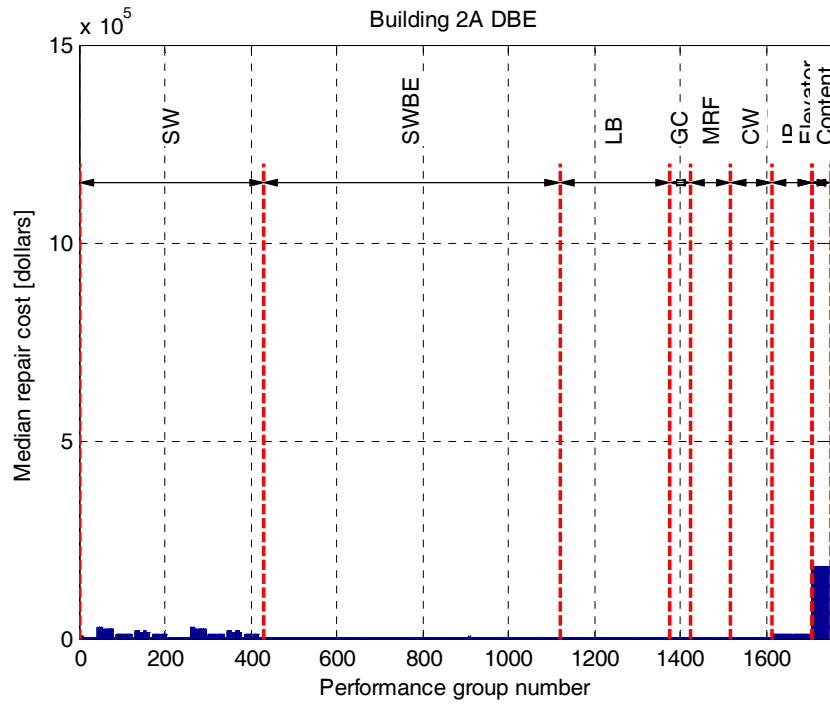

Figure 6.52 Deaggregation of median repair cost for Building 2A at DBE hazard level.

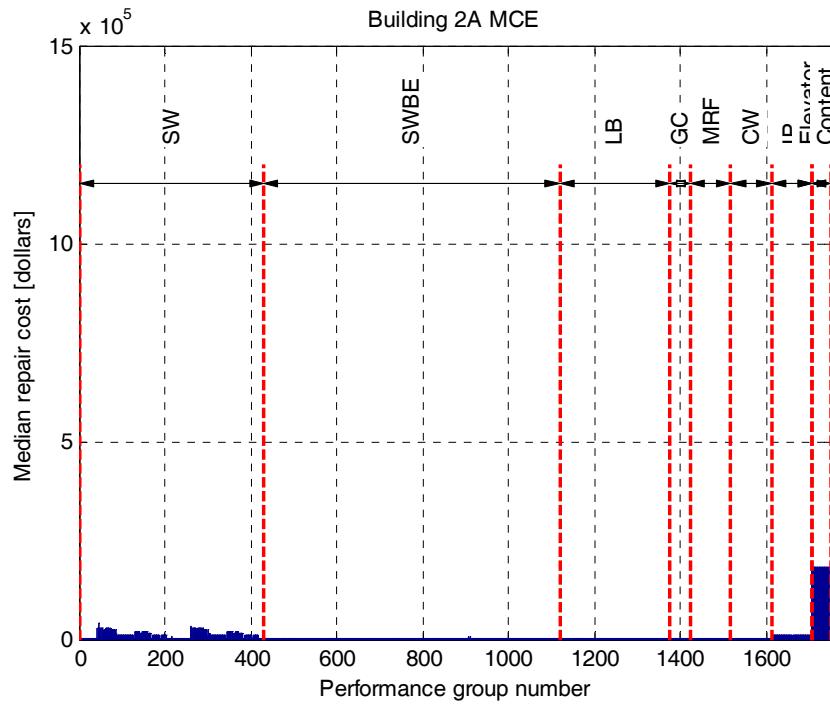

Figure 6.53 Deaggregation of median repair cost for Building 2A at MCE hazard level.

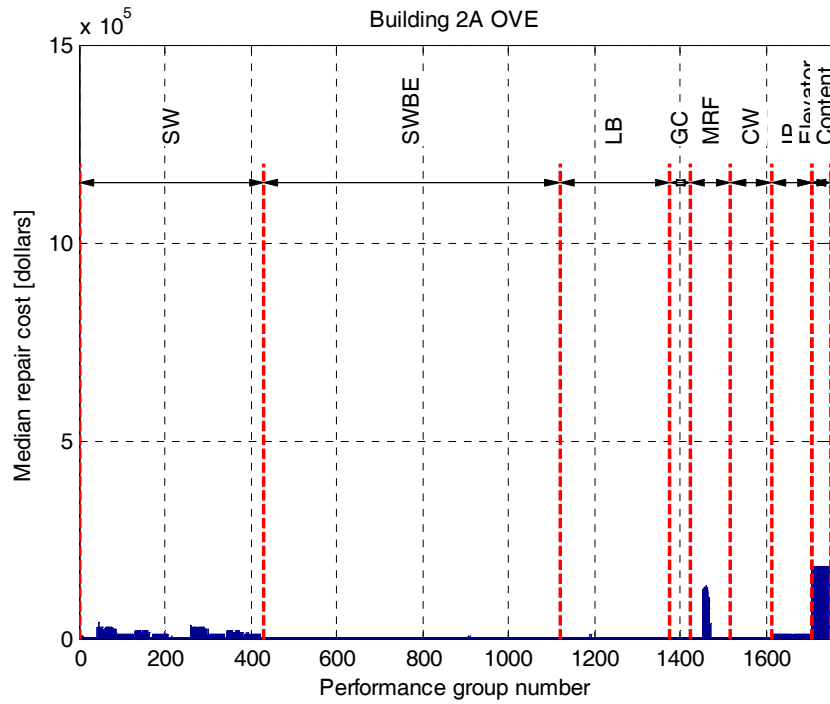

Figure 6.54 Deaggregation of median repair cost for Building 2A at OVE hazard level.

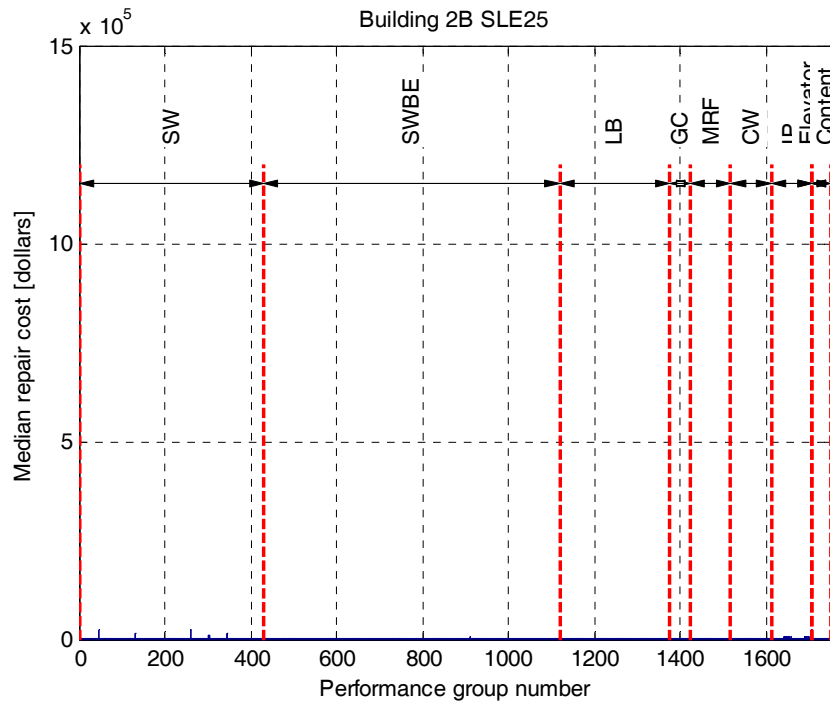

Figure 6.55 Deaggregation of median repair cost for Building 2B/2C at SLE25 hazard level.

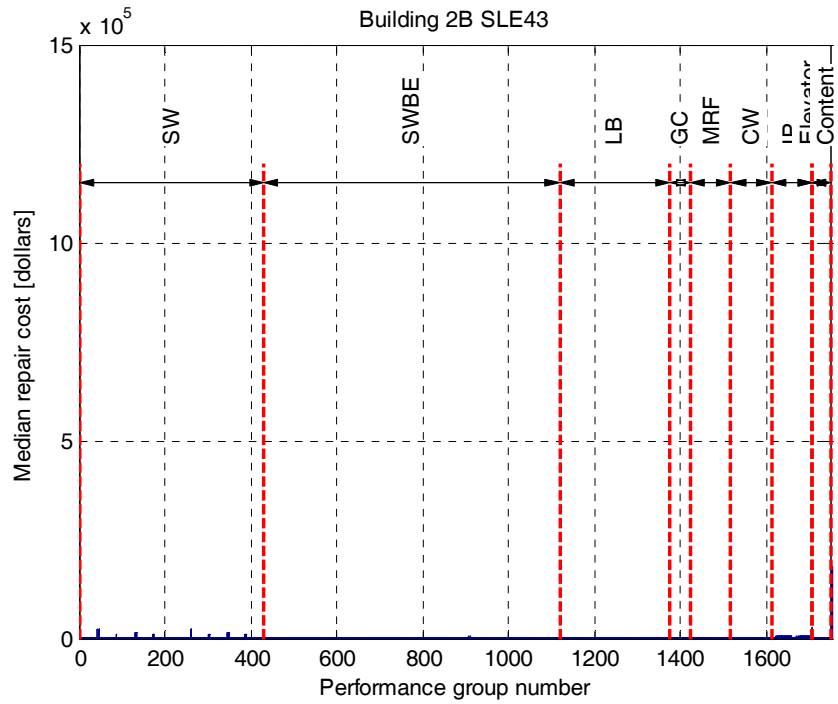

Figure 6.56 Deaggregation of median repair cost for Building 2B/2C at SLE43 hazard level.

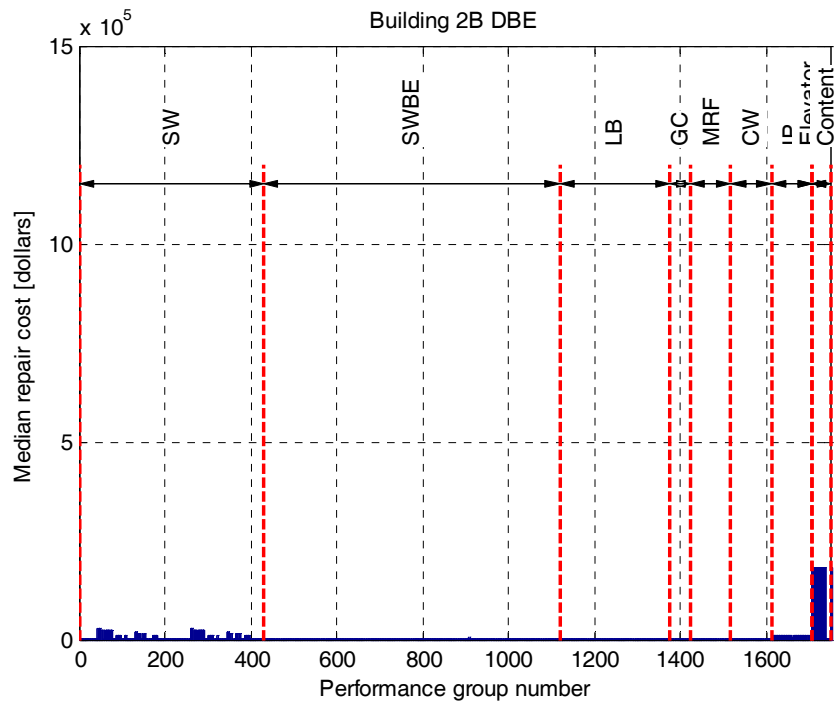

Figure 6.57 Deaggregation of median repair cost for Building 2B/2C at DBE hazard level.

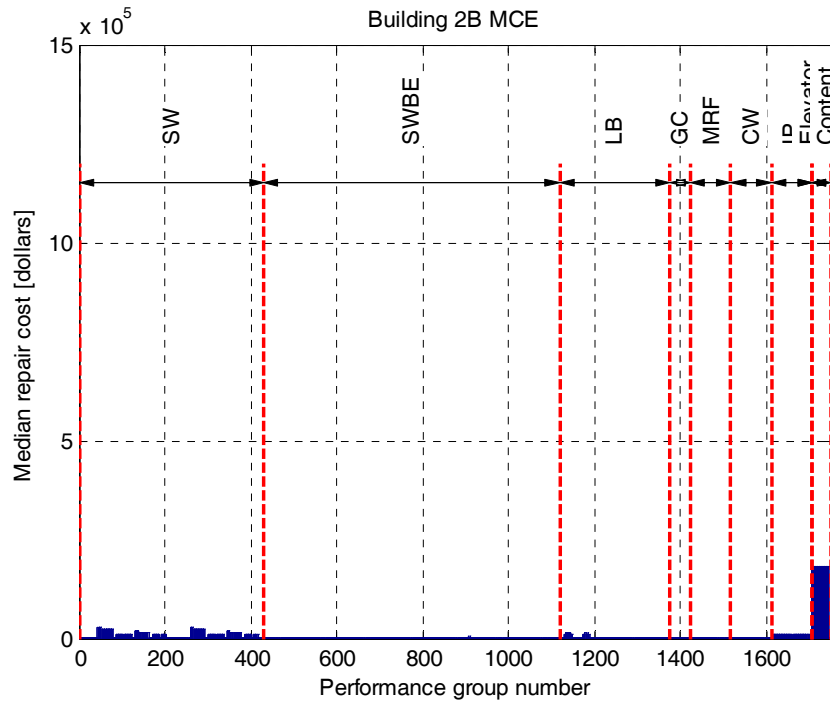

Figure 6.58 Deaggregation of median repair cost for Building 2B/2C at MCE hazard level.

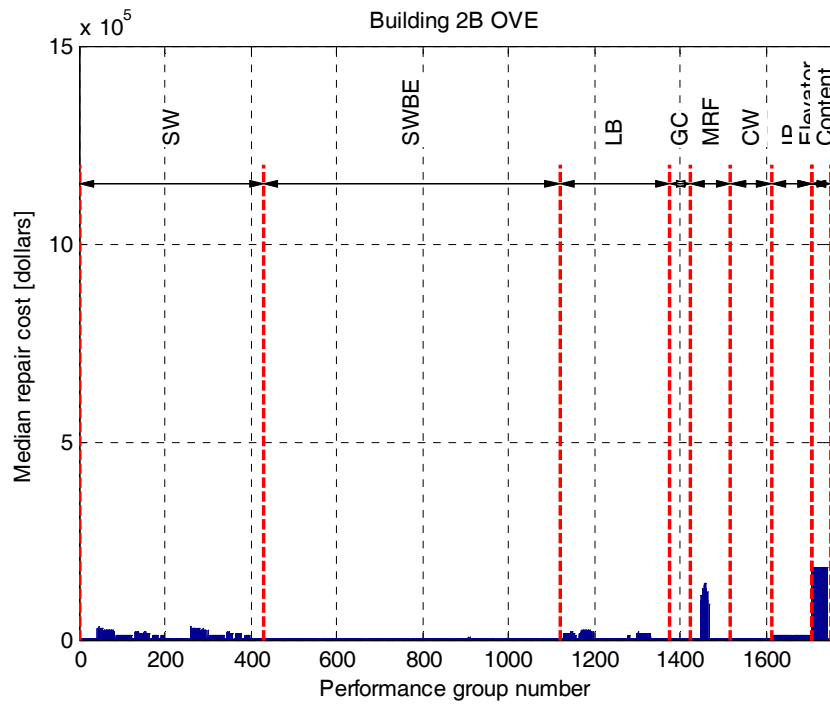

Figure 6.59 Deaggregation of median repair cost for Building 2B/2C at OVE hazard level.

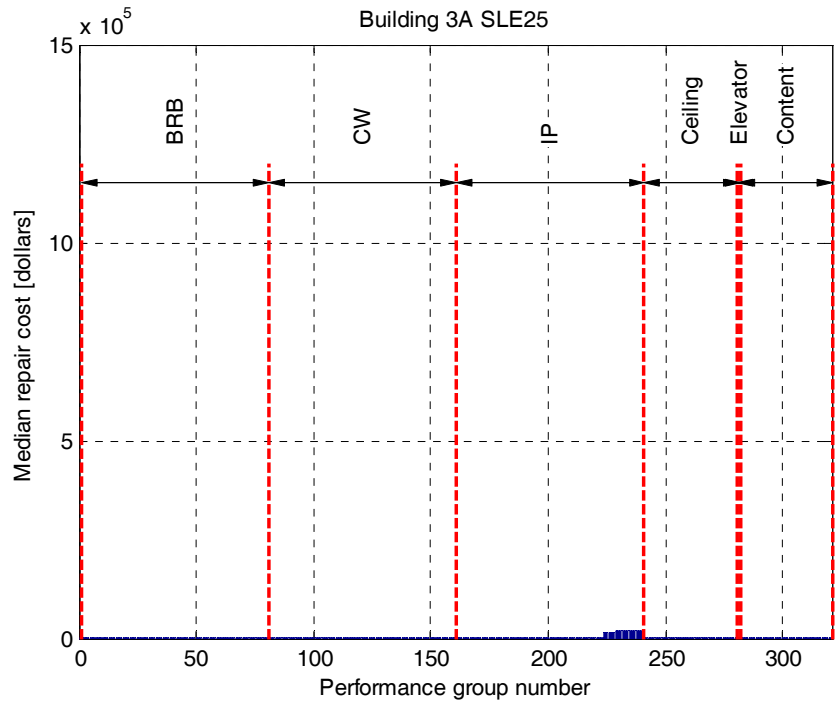

Figure 6.60 Deaggregation of median repair cost for Building 3A at SLE25 hazard level.

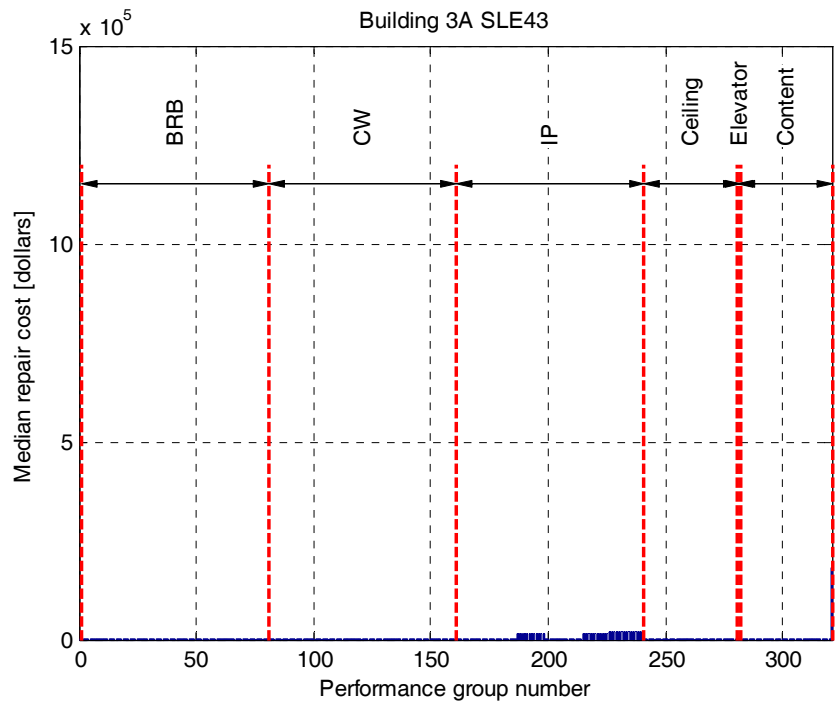

Figure 6.61 Deaggregation of median repair cost for Building 3A at SLE43 hazard level.

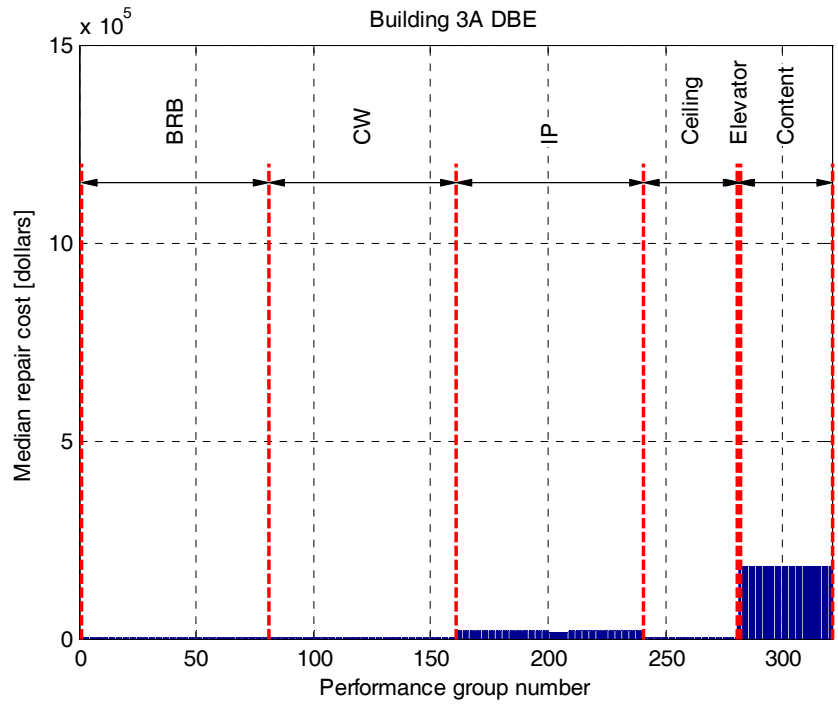

Figure 6.62 Deaggregation of median repair cost for Building 3A at DBE hazard level.

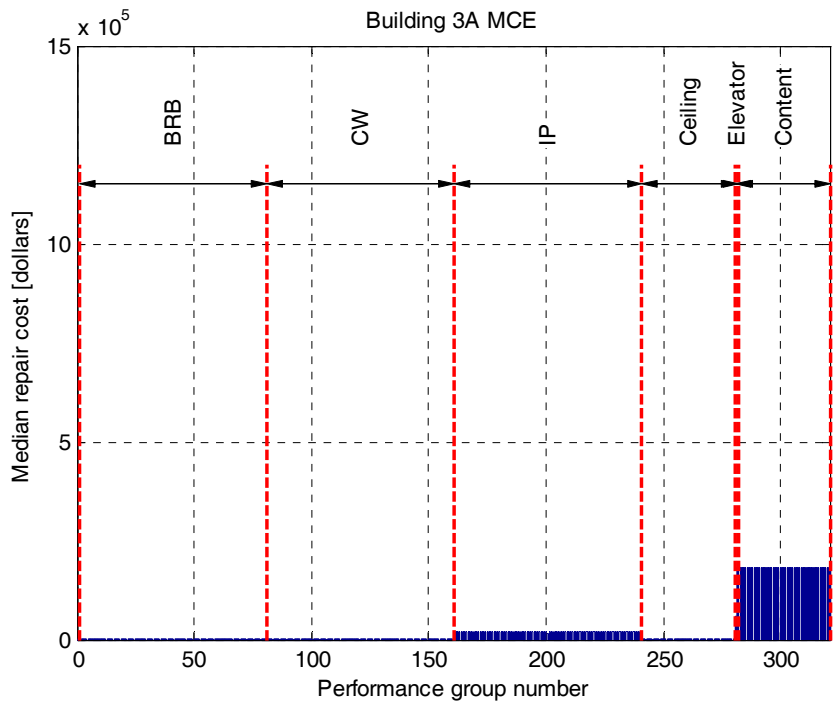

Figure 6.63 Deaggregation of median repair cost for Building 3A at MCE hazard level.

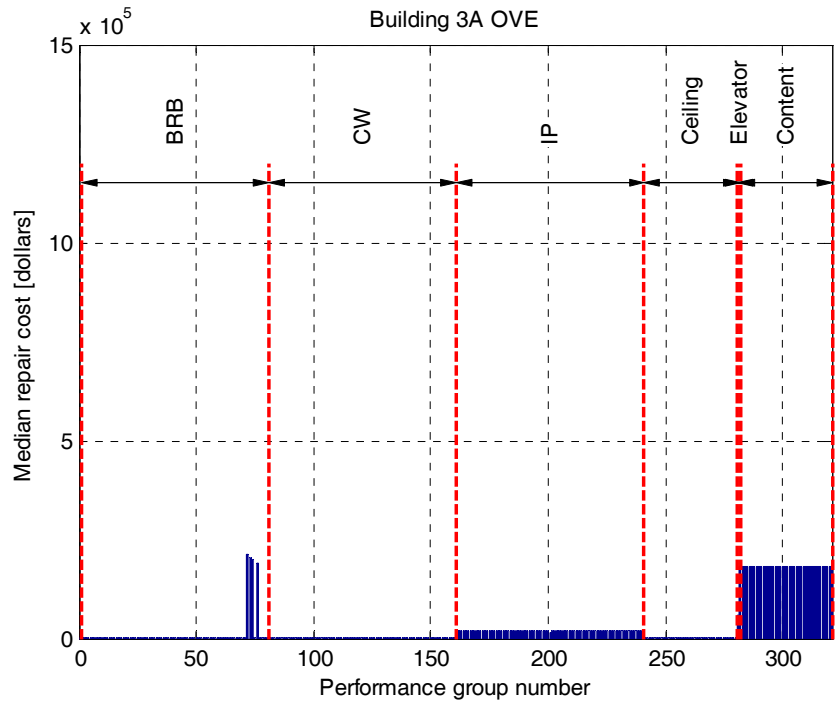

Figure 6.64 Deaggregation of median repair cost for Building 3A at OVE hazard level.

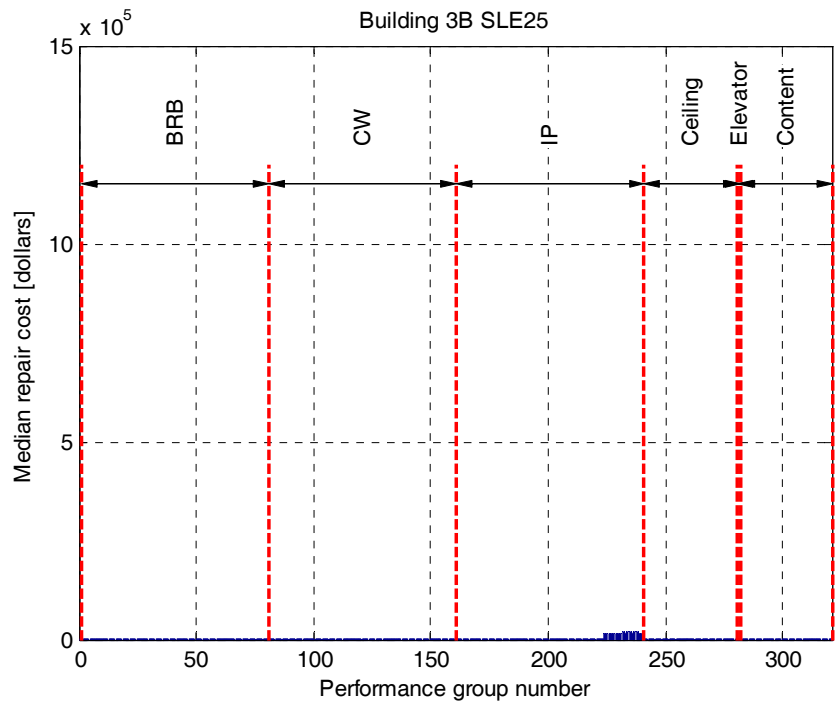

Figure 6.65 Deaggregation of median repair cost for Building 3B at SLE25 hazard level.

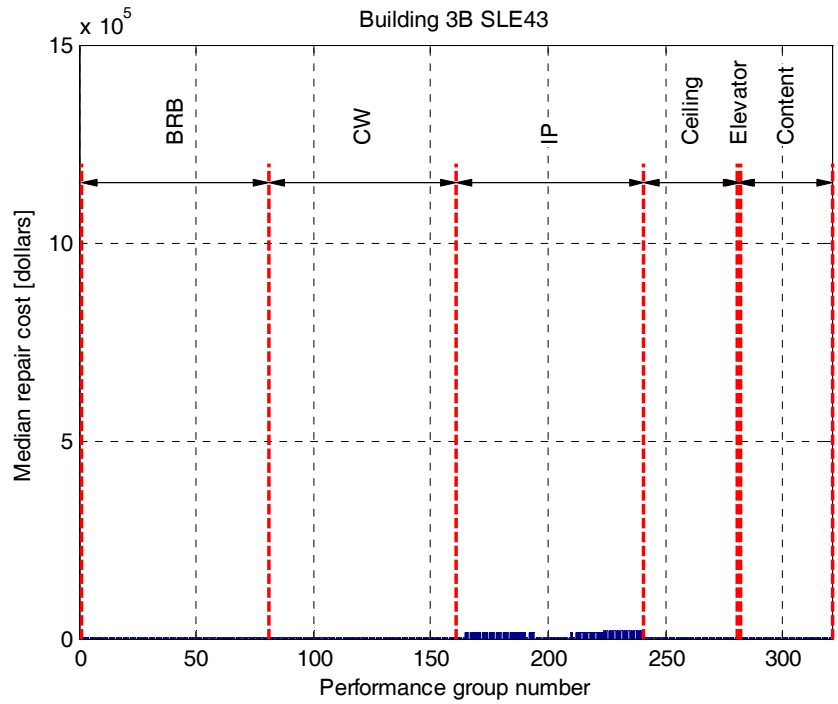

Figure 6.66 Deaggregation of median repair cost for Building 3B at SLE43 hazard level.

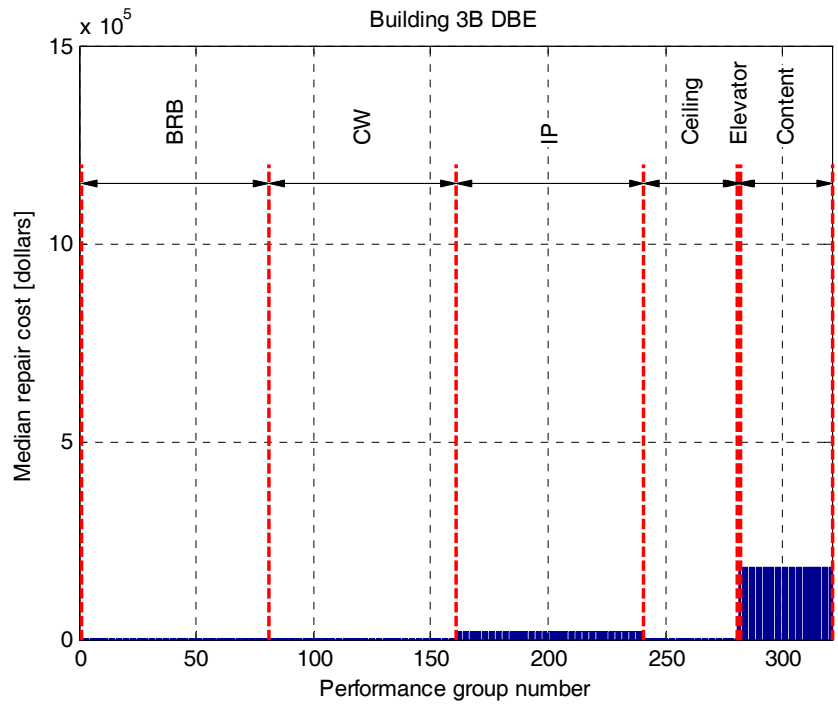

Figure 6.67 Deaggregation of median repair cost for Building 3B at DBE hazard level.

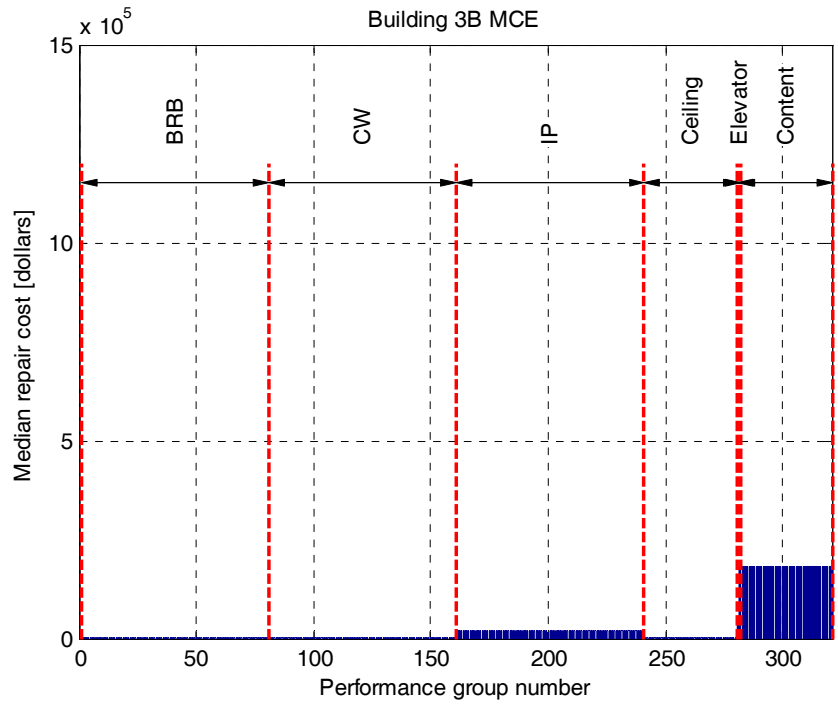

Figure 6.68 Deaggregation of median repair cost for Building 3B at MCE hazard level.

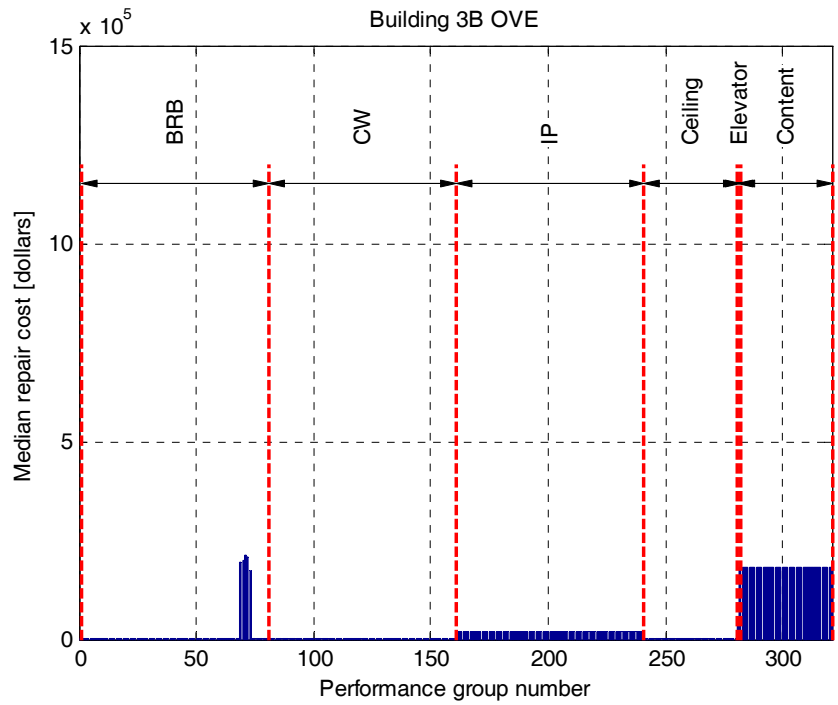

Figure 6.69 Deaggregation of median repair cost for Building 3B at OVE hazard level.

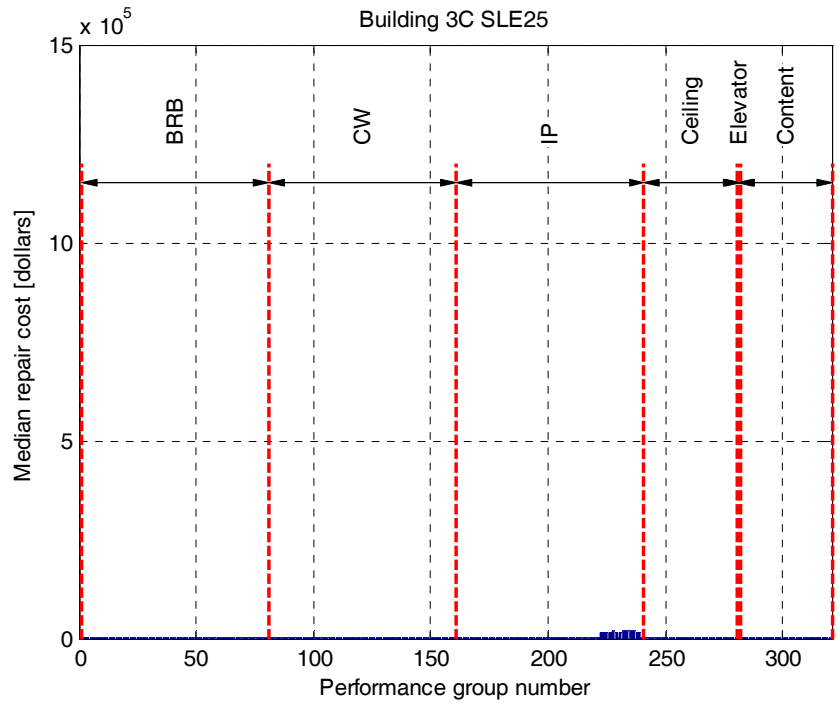

Figure 6.70 Deaggregation of median repair cost for Building 3C at SLE25 hazard level.

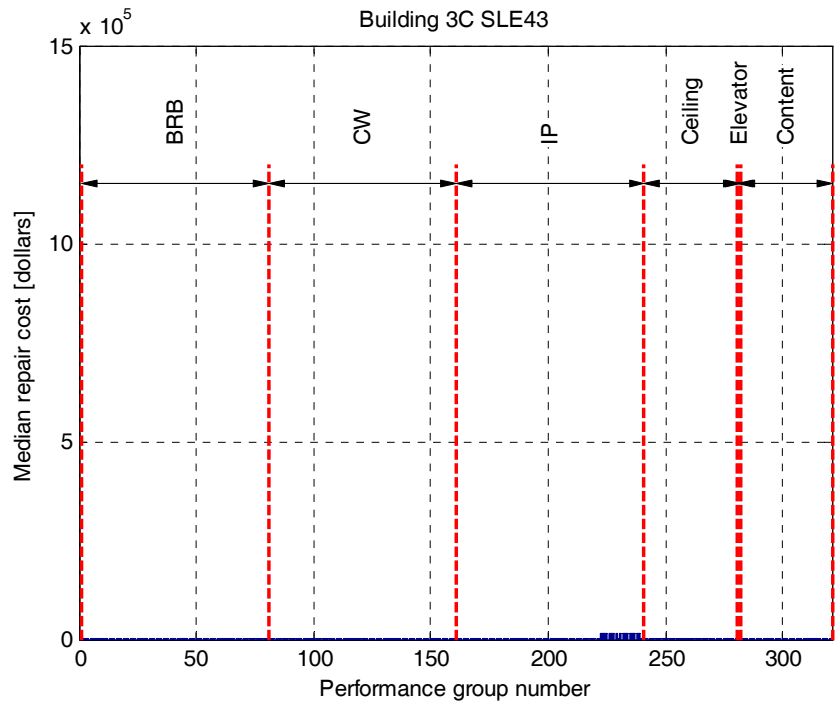

Figure 6.71 Deaggregation of median repair cost for Building 3C at SLE43 hazard level.

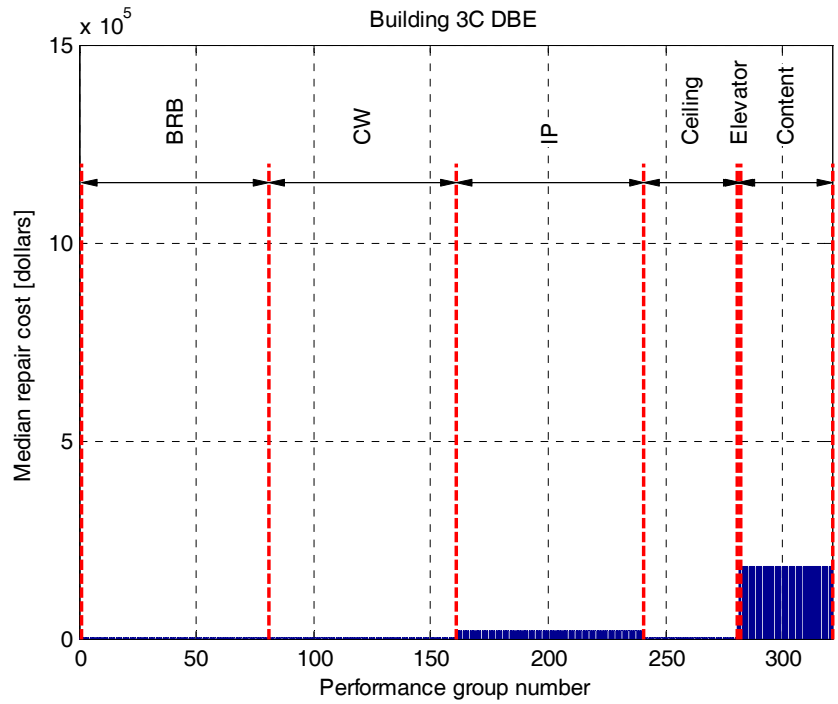

Figure 6.72 Deaggregation of median repair cost for Building 3C at DBE hazard level.

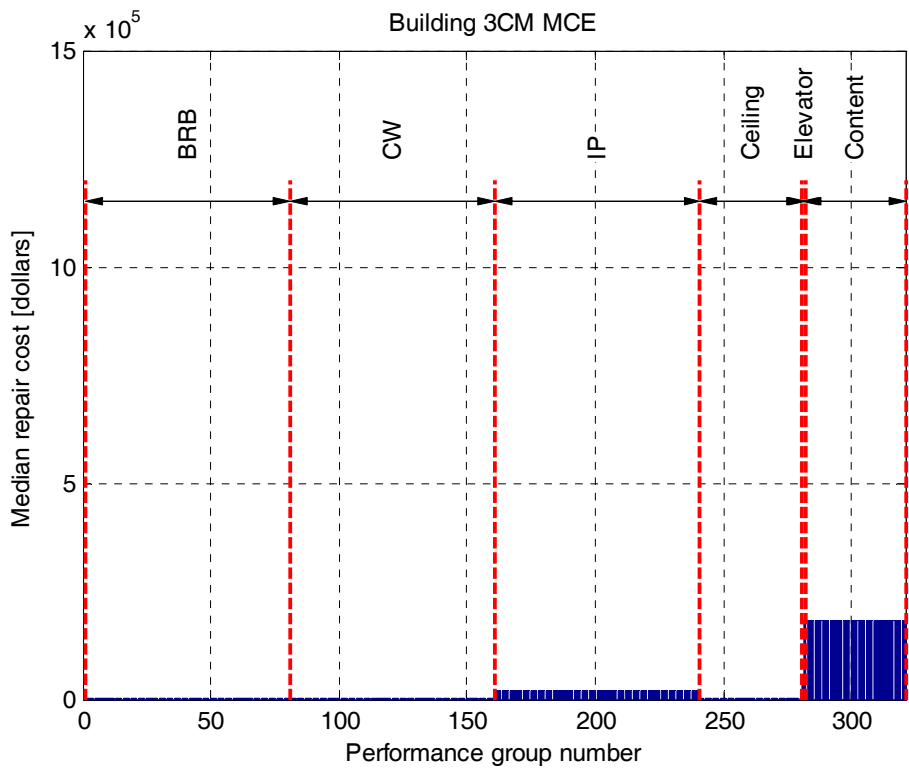

Figure 6.73 Deaggregation of median repair cost for Building 3C at MCE hazard level.

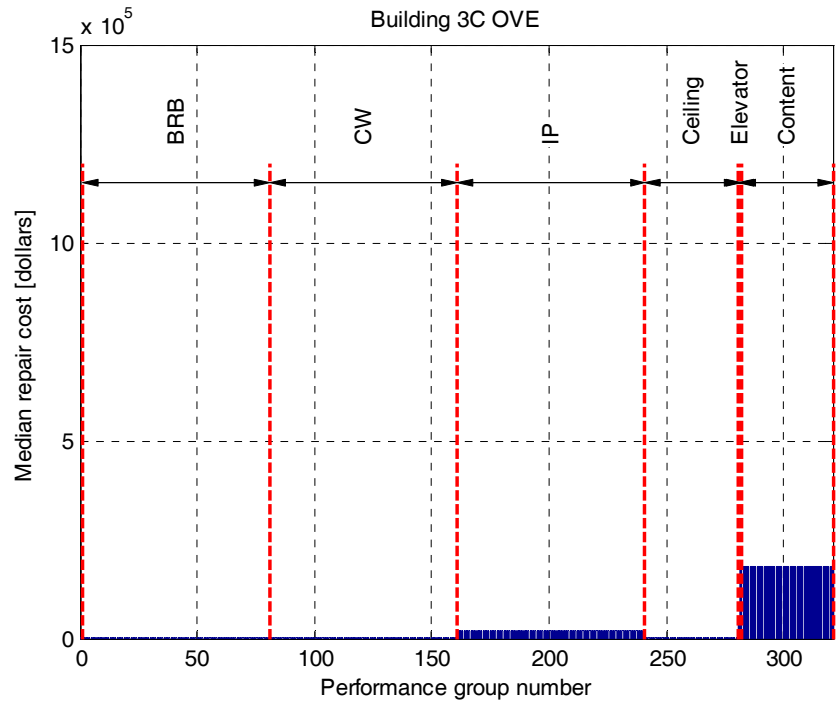

Figure 6.74 Deaggregation of median repair cost for Building 3C at OVE hazard level.

7 Summary and Conclusions

7.1 SUMMARY

This report summarizes the results of case studies on the design and performance assessment of a series of tall buildings designed by building code prescriptive provisions and by two performance-based seismic design procedures. The studies are part of the *Tall Buildings Initiative* undertaken by the Pacific Earthquake Engineering Research Center. The specific studies summarized in this report are:

1. The selection and scaling of earthquake ground motions for a characteristic geographic location in the City of Los Angeles. The work is underpinned by studies of the selection and scaling of ground motions as well as state-of-the-art work on simulated earthquake ground motions for extreme hazard levels.
2. The design of three building types (concrete core only, concrete dual system comprising core wall and SMF, and steel buckling-restrained brace system), each according to the International Building Code [2006], the Los Angeles Tall Buildings Structural Design Council Alternative Procedure for Seismic Design of Tall Buildings Located in the Los Angeles Region [LATBSDC 2008], and the PEER Tall Buildings Initiative Performance-Based Seismic Design Guidelines for Tall Buildings [TBI 2010].
3. Extensive analytical studies of the seismic structural performance of the designed buildings subjected to two horizontal components of earthquake ground motions scaled to represent motions having return period ranging from 25 years to 4975 years.
4. Analysis of the initial construction costs and projected repair costs considering anticipated earthquake ground motions.

The main body of this report presents details on the aforementioned studies. Appendices A through C present the building design reports submitted by practicing structural engineers engaged to design the buildings. Appendix D presents the construction cost report submitted by the construction cost contractor engaged for this work.

7.2 CONCLUSIONS

7.2.1 Seismic Hazard

Seismic hazard at the case building study site was controlled by multiple seismic sources, including known faults as close as 1.5 km (Puente Hills fault) and as far as 56 km (San Andreas fault).

Using the NGA database as a resource, 15 pairs of earthquake ground motion recordings were selected that, when amplitude scaled, provided a reasonable match to the target uniform hazard spectra for return periods 25, 43, 475, 2475, and 4975 years. These hazard levels are denoted as SLE25, SLE43, DBE, MCE, and OVE, respectively. It was necessary to supplement the NGA database with synthetic motions for the 4975-year return period (i.e., 8 recorded and 7 synthetic motions here used).

The fundamental period of the case study buildings was around 5 sec. Therefore, considering higher modes and effective period lengthening due to inelastic actions, the period range of interest is between about 1 s to 7.5 s, a range typical of tall buildings. It is difficult to identify un-scaled ground motion records with significant energy content over this entire period range. An amplitude scaling routine—developed as part of this project—was reasonably successful in achieving the target shaking intensities. Although spectrum matching may facilitate the ground motion selection and scaling process, this approach was not selected for performance assessment of the case study buildings because of concerns about lack of dispersion in the input motion. Use of scenario or conditional mean spectra was not pursued because of concerns that such spectra would not adequately excite the multiple periods that affect response of tall buildings.

7.2.2 Case Study Building Designs

Building 1 was a 42-story residential building using a concrete core wall as the seismic-force-resisting system supplemented by post-tensioned flat-plate framing for additional gravity load

resistance. The designs were implemented by a Seattle engineering firm with experience in the design of this type of structural system. The design base shear (maximum direction) increased progressive from Design 1A (4600 kips) to Design 1B (6000 kips) to Design 1C (8200 kips). Design base shear strength for Design 1A was controlled by code minimum strength, whereas design base shear for the other two designs was controlled by the serviceability level design. The design—governed by wall shear, required wall thickness, and vertical reinforcement—increased from Design 1A to 1B to 1C, with a corresponding decrease in building periods. In contrast, the allowance in the TBI Guidelines for 1.5 overload of ductile elements resulted in weaker coupling beams in Design 1C than in the other two designs.

Building 2 was a 42-story residential building using dual system consisting of a concrete core wall and a concrete perimeter SMF as the seismic-force-resisting system. The designs were prepared by a Los Angeles engineering firm experienced in designing this type of structural system. Design 2A was prepared according to IBC 2006, and Design 2B was prepared according to the LATBSDC criteria. When Design 2B was checked by the modal-spectral procedure of the TBI Guidelines, it was found deficient for the service level requirements; however, it passed the alternative nonlinear analysis option contained in the TBI Guidelines. Consequently, only two different designs were developed for this building. It is noteworthy that the nonlinear option for service-level design, contained in the TBI Guidelines, allowed for approving a building of lower strength than would be required by the modal-spectral procedure. Also of note was the design of the SMF columns. The IBC provisions permit the design of columns much smaller (36 in. square) than required by the performance-based designs (46 in. square), causing some concern about performance of the code-based design.

Building 3 was a 40-story office building using BRB frames as the seismic-force-resisting system. The designs were prepared by a San Francisco engineering firm with experience in designing this type of structural system. For Building 3A, IBC 2006 contains prescriptive design requirements that resulted in very strong columns compared with the other designs. In Building 3B, due to less stringent design criteria in the LATBSDC criteria compared to IBC 2006, the number and size of BRBFs and cross sections of columns were reduced. For Building 3C, the more stringent serviceability earthquake requirements increased the design demands and led the design team to introduce outriggers in the structural system. Thus, three different structural systems resulted from the three design criteria.

7.2.3 Structural Performance of the Case Study Buildings

Calculated response for the case study buildings generally fell within targeted performance limits. Specifically, median interstory drift ratios for the serviceability level fell within intended serviceability drift limits (which varied from one design to another), and median drift ratios for MCE shaking were less than the target value of 0.03. All but two building models “survived” the OVE shaking level without collapse; analyses for both Buildings 1A and 2A failed to converge for one of the synthetic OVE ground motions. It is noteworthy that although the return period for the OVE is twice that for MCE, the linear spectral ordinate for OVE near the first-mode period is only about 1.3 times that of MCE.

For both Building 1 and Building 2, the core walls were calculated to respond within acceptable limits. For MCE shaking, mean wall shear stresses for the code-based designs approached the upper limit permitted by the code; the TBI Guidelines provided the most conservative design for wall shear. For OVE shaking, a few core walls in the code-based design reached or exceeded safe limits for shear, but the excursions were few and not significantly past safe limits. Core wall strains indicated that flexural yielding occurred, with compressive and tensile strains well within accepted limits. Coupling beam rotations were largest for the TBI Guidelines designs, but were within accepted limits for MCE shaking.

In the dual system, SMF beams responded within acceptable limits for all shaking levels. The SMF columns of the code-based design sustained axial loads approaching the axial capacity, but corresponding deformation demands were low suggesting that the columns would not experience strength loss for the calculated demands. It is speculated, however, that a less conservative column design, which is possible given the code design procedures, might result in a building where column axial failure could occur. Some revisions to column design procedures to consider the high axial forces should be considered. In contrast, the performance-based designs performed well within accepted limits.

The steel buildings appeared to have performed acceptably. Residual interstory drifts occurred in these buildings that were not observed for the concrete buildings. In all cases, residual drifts were within limits established by the TBI Guidelines, but some repair cost (not reflected in the repair costs reported in Chapter 6) would be incurred. Comparisons among the three steel building designs are complicated because the geometries of the three buildings are different from one another.

7.2.4 Financial Aspects of the Case Study Buildings

Initial costs were strongly affected by choice of structural system (concrete versus steel) but was not much affected by the design method (prescriptive or performance-based).

One set of loss estimates was based on current state-of-practice. This loss estimate had the following principal conclusions:

- For code-designed buildings, the ground-up losses (entire amount of insurance loss, including deductibles, before application of any retention or reinsurance) was highest for the core-wall building. Losses for the dual system and the BRB frame system were about 30% to 40% lower than for the core-wall system.
- The losses for the performance-based designs were lower than those for the code-based designs. This conclusion applies to these case study buildings and may not apply generally.
- Relative contribution of structural and nonstructural costs varies significantly with intensity of ground motion, the latter being the larger contributor for low-intensity shaking and the former being a larger portion for high-intensity shaking.
- The distribution pattern of damage with height varies with shaking intensity. Losses are highest in upper stories initially, but losses in lower stories increase non-proportionally with increasing shaking intensity. For lower-intensity shaking, damage was primarily due to acceleration-sensitive performance groups. As intensity increased, acceleration-sensitive damage saturated and drift-sensitive damage increased.
- Although the results indicate that the performance of the dual system is best among all three building systems, the loss results of the dual system and BRB are within statistical noise levels.

A second set of loss estimates was conducted based on the ATC-58 methodology with the following conclusions:

- Representing the structural, nonstructural, and contents components using the ATC-58 methodology required incorporating large numbers of performance groups. Furthermore, the presence of large numbers of EDPs was beyond the capability of the PACT software implemented by ATC-58, which required developing specialized routines to conduct this study outside the PACT software. Revisions to PACT have

been recommended to enable it to solve large systems such as those encountered in this project. Those revisions are in progress at the time of this writing.

- The ATC-58 fragility database provided most of the information required for the study. However, it was necessary to develop additional fragility and consequence functions. This was done in collaboration with the ATC-58 project team, and results were provided for implementation in the ATC-58 project.
- In general, as the design methodology shifted from A to B to C, the median repair cost of the building, regardless of structural system, decreased.
- As a fraction of initial construction cost, Building 3 (BRB frame building) had the lowest repair costs. Given that, residual displacement was not considered in developing losses, and these were highest for Building 3. Buildings 1 and 2 generally showed similar losses, even though there were some differences from one design to another.
- Mean annual repair costs, as well as the estimated probable maximum losses (PMLs), were lowest for the buildings designed by the TBI Guidelines. This is likely a result of the more stringent serviceability design requirements.
- Total Cost was defined as the sum of the initial cost and the net present value of insurance payments, where insurance payments were assumed equal to the mean annualized loss calculated for each building design. For Building 1, the performance-based designs had negligible influence on Total Cost. For Building 2, the performance-based designs added 15% to the Total Cost. For Building 3, the performance-based designs resulted in minor reductions in Total Cost. Note that these results are insensitive to the assumed time value of money. It is emphasized that the performance-based designs were not oriented toward optimization of Total Cost, but instead were oriented toward more reliable performance by more explicit representation of the building properties in the design process.
- The ATC-58 methodology provides detailed information on the source of losses for all buildings. This has the potential to inform the designer of where losses are concentrated so that design revisions can be made based on this information.

REFERENCES

- American Concrete Institute (1992). (1992). *ACI Manual of Concrete Practice*, ACI Committee 363, ACI 363-92, Detroit, MI.
- American Concrete Institute (2008). *Building Code Requirements for Structural Concrete and Commentary*, American Concrete Institute Committee 318, ACI 318-08.
- American Society of Civil Engineers (2005). *Minimum Design Loads for Buildings and Other Structures*, ASCE/SEI 7, Reston, VA.
- Applied Technology Council (2009). Guidelines for Seismic Performance Assessment of Buildings (50% Draft), *ATC-58*, Redwood City, CA.
- Aslani H, Miranda E (2005). Probabilistic earthquake loss estimation and loss disaggregation in buildings, *Report No 157*, The John A. Blume Earthquake Engineering Center, Stanford University, Stanford, CA.
- Baker JW, Cornell CA (2006). Which spectral acceleration are you using? *Earthq. Spectra*, 22(2):293-312.
- Baker JW (2008). Introducing correlation among fragility functions for multiple components, *Proceedings, 14th World Conference on Earthquake Engineering*, Beijing, China.
- Computer and Structures, Inc (2009). *Perform-3D:Nonlinear Analysis and Performance Assessment for 3D Structures*, Berkeley, CA.
- Cornell CA, Krawinkler H (2000). Progress and challenges in seismic performance assessment, *PEER Center News*, 3(2).
- Dutta A, Hamburger RO (2009a). Detailed Design Write up for BRBF Building,. Simpson Gumpertz & Heger, Appendix C of this report.
- Dutta A, Hamburger RO (2009b). Schematic Drawings of Case Study 40 story BRBF Frame. San Francisco: Simpson Gumpertz & Heger, San Francisco, CA.
- Dutta A, Hamburger RO (2010). Case study of a 40-story buckling-restrained braced frame building located in Los Angeles, *The Structural Design of Tall and Special Buildings*, 19(1-2):77-93.
- Federal Emergency Management Agency (1997). *NEHRP Guidelines for the Seismic Rehabilitation of Buildings*, FEMA-273, Washington, D.C.
- Federal Emergency Management Agency (2000). *State of the Art Report on Performance Prediction and Evaluation of Steel Moment-Frame Buildings*, FEMA-355F, Washington, D.C.
- Federal Emergency Management Agency (2003). *NEHRP Recommended Provisions for Seismic Regulations for New Buildings and Other Structures*, FEMA-450, Washington, D.C.
- Fry JA, Hooper JD, Klemencic R (2010). Building 1, core wall only, sample design for PEER/CSSC, Appendix A of this report.
- Fry JA, Hooper JD, Klemencic R (2010). Core wall case study design for Pacific Earthquake Engineering Research/ California seismic safety commission, *The Structural Design of Tall and Special Buildings*, 19(1-2):61-75.
- Ghodsii T, Ruiz JF, Massie C, Chen Y (2009). PEER/ SSC tall building design case history no. 2, Appendix B of this report.
- Ghodsii T, Ruiz JF, Massie C, Chen Y (2010). PEER/ SSC tall building design case history no. 2, *The Structural Design of Tall and Special Buildings*, 19(1-2):197-256.
- HAZUS-MH MR3 (2003). *Technical Manual -Multi-hazard Loss Estimation Methodology, Earthquake Model*, Federal Emergency Management Agency, Washington, DC.
- Haselton CB, Liel AB, Deierlein GG, Dean BS, Chou JH (2011). Seismic collapse safety of reinforced concrete buildings: I. Assessment of ductile moment frames, *ASCE, J. Struct. Engng.*, 137(4):481-491.
- International Code Council (2006). *International Building Code*, Falls Church, VA.
- Jayaram N, Shome N, Krawinkler H, Rahnama M (2011). Development of earthquake vulnerability functions for tall buildings, *Earthquake Engineering and Structural Dynamics* (to be published).

- Langdon (2010a). *Cost Model for PEER Tall Buildings Study: Concrete Structural Option. Final Report*, <http://peer.berkeley.edu/tbi/publications-reports/>
- Langdon (2010b). *Cost Model for PEER Tall Buildings Study: Concrete Dual System Structural Option. Final Report*, <http://peer.berkeley.edu/tbi/publications-reports/>
- Langdon (2010c). *Cost Model for PEER Tall Buildings Study: Steel Structural Option. Final Report*, <http://peer.berkeley.edu/tbi/publications-reports/>
- LATBSDC (2008). *An Alternative Procedure for Seismic Analysis and Design of Tall Buildings Located in the Los Angeles Region*, Los Angeles Tall Buildings Structural Design Council, Los Angeles, CA.
- Mander JB, Priestley MJN, Park R (1988). Theoretical stress-strain model for confined concrete, ASCE, *J. Struct. Engrg.*, 114(8):1804-1826.
- Moehle J, Bozorgnia Y, Hurtado G, Jones P, Tuna Z, Wallace J, Yang T., Zareian AF (2009). Final Report to the City of Los Angeles for the Tall Buildings Initiative, Pacific Earthquake Engineering Research Center, Berkeley, CA.
- Naish D (2010). Testing and modeling of reinforced concrete coupling beams, PhD Dissertation, Department of Civil and Environmental Engineering, University of California, Los Angeles, CA, pp. 125 pgs.
- Naish D, Wallace JW, Fry JA, Klemencic R (2009). Reinforced concrete link beams: alternative details for improved construction, *SGEL Report 2009/06*, University of California, Los Angeles, CA.
- Orakcal K, Wallace JW (2006). Flexural modeling of reinforced concrete walls-experimental verification, *ACI Struct. J.*, 103(2).
- Pacific Earthquake Engineering Research Center (2010). Guidelines for performance-based seismic design of tall buildings, *Report PEER-2010/05*, Pacific Earthquake Engineering Research Center, University of California, Berkeley, CA.
- Popov EP, Bertero VV, Krawinkler H (1972). Cyclic behavior of three R.C. flexural members with high shear, *Report No. EERC 72-5*, Earthquake Engineering Research Center, University of California, Berkeley, CA.
- Ramirez CM, Miranda E (2009). Building-specific loss estimation methods & tools for simplified performance-based earthquake engineering, *Report No. 171*, The John A. Blume Earthquake Engineering Center, Stanford University, Stanford, CA.
- Salas MC (2008). Modeling of tall reinforced concrete wall buildings, M.S. Thesis, Dept. of Civil and Environmental Engineering, University of California, Los Angeles, CA.
- Shome N, Cornell CA (1999). Probabilistic seismic demand analysis of nonlinear structures, *RMS Tech Report, Reliability of Marine Structures*, Stanford University, Stanford, CA.
- Structural Engineers Association of California (1999). *Performance-based Seismic Engineering*, The Blue Book,, Sacramento, CA.
- Yang TY Moehle JP, Stojadinovic B, Der Kiureghian A (2009). Performance evaluation of structural systems: theory and implementation, ASCE, *J. Struct. Engrg.*, 135(10):1146–1154.

**Appendix A: Design Report for Building 1 --
Core Wall Only Structural System**

ANALYSIS AND DESIGN FINAL REPORT

“Building 1 – Core Wall Only” Sample Design for
PEER/CSSC
Los Angeles, California

December 9, 2009



MAGNUSSON
KLEMENCIC
ASSOCIATES

Structural + Civil Engineers

1301 Fifth Avenue, Suite 3200

Seattle, Washington 98101-2699

T: 206 292 1200 F: 206 292 1201

PROJECT DESCRIPTION	1
ANALYSIS AND DESIGN COMPARISON	7
BUILDING CODES	9
Building Codes	9
Material Codes	10
LOADING CRITERIA	10
Gravity Loading	10
Wind Design Criteria	11
Seismic Design Criteria	12
Seismic Response Spectra and Ground Motions for Non-Linear Response History Analysis	13
MATERIALS	14
ANALYSIS AND DESIGN SOFTWARE	15
LOAD COMBINATIONS	
Building 1A Load Combinations	16
Building 1B and 1C Serviceability Load Combinations	17
Building 1B and 1C MCE Load Combinations	17
LATERAL MODEL SUMMARY	
Elastic Models	18
Non-Linear Models	20
ACCEPTANCE CRITERIA	20
Serviceability Analysis	20
NLRHA Acceptance Criteria	21
DESIGN SUMMARY	
Building 1	22
Design Comparison Results	23
OBSERVATIONS AND CONCLUSIONS	43

APPENDICES

- Appendix 1: Rebar Design Drawings (Buildings 1A, 1B, and 1C)
- Appendix 2: Coupling Beam Design Charts (Buildings 1A, 1B, and 1C)
- Appendix 3: Drift Plots – MCE Level (Buildings 1B and 1C)
- Appendix 4: Shear and Overturning Plots – MCE Level (Buildings 1B and 1C)
- Appendix 5: Coupling Beam Rotations – MCE Level (Buildings 1B and 1C)
- Appendix 6: Compression and Tension Strains – MCE Level (Buildings 1B and 1C)
- Appendix 7: Wall Panel Shear – MCE Level (Buildings 1B and 1C)



PROJECT DESCRIPTION

Magnusson Klemencic Associates (MKA) performed the structural design for a sample building on behalf of the Pacific Earthquake Engineering Research Center (PEER) as part of the Tall Buildings Initiative (TBI). The research project is done on behalf of the California Seismic Safety Commission (CSSC) and the California Office of Emergency Services. The goal of the overall research project is to quantify and compare seismic performance and expected losses of three hypothetical, yet realistic, tall buildings in California.

The building designed by MKA consists of a representative structure with concrete core walls alone serving as the lateral system. The building is located in Los Angeles, California, and is a 42-story hotel. For the purposes of reporting, the building designed by MKA is called Building 1.

Three different designs for Building 1 were performed, as summarized below:

- **Building 1A: Prescriptive provisions of the IBC.** All prescriptive provisions of the building code, the 2006 edition of the International Building Code (IBC), were observed with one exception: the height limit. Capacity design principles were not employed. A non-linear model of the resulting design was created; however, a Non-Linear Response History Analysis (NLRHA) was not performed.
- **Building 1B: Performance-based design per LATBSDC criteria.** A performance-based design (PBD) was performed according to the 2008 edition of the seismic design criteria published by the Los Angeles Tall Buildings Structural Design Council (LATBSDC), with the following exceptions:
 - The serviceability analysis considered an earthquake event with a 25-year mean recurrence interval (MRI) and 2.5 percent viscous damping. Less than 20 percent of the ductile elements were allowed to reach 150 percent of their capacity in the serviceability analysis.
 - The minimum base shear specified in the LATBSDC document was waived. The serviceability earthquake in conjunction with design for wind forces determined the minimum strength of the lateral system.
- **Building 1C: Higher seismic hazard PBD per PEER guidelines.** A performance-based design was performed similar to Building 1B but in accordance with the draft Guidelines for Seismic Design of Tall Buildings dated August 4, 2009, as developed by the PEER under its TBI. For this design the serviceability analysis considered an earthquake event with a 43-year MRI and 2.5 percent viscous damping. All ductile elements were allowed to reach 150 percent of their capacity in the serviceability analysis.

The seismological data (response spectra and earthquake records) for use in the design of the project were provided by Mactec. Three sets of earthquake records were provided by Mactec:

- Original Records: Used to complete the design of Building 1B.
- Revised Records: Used to complete the design of Building 1C. The results in this report for Building 1B also consider the revised records. However, the design for Building 1B was not updated.
- Service-Level Records: Not used in MKA's design.

Conceptual images of Building 1 are shown in Figures 1 through 5.

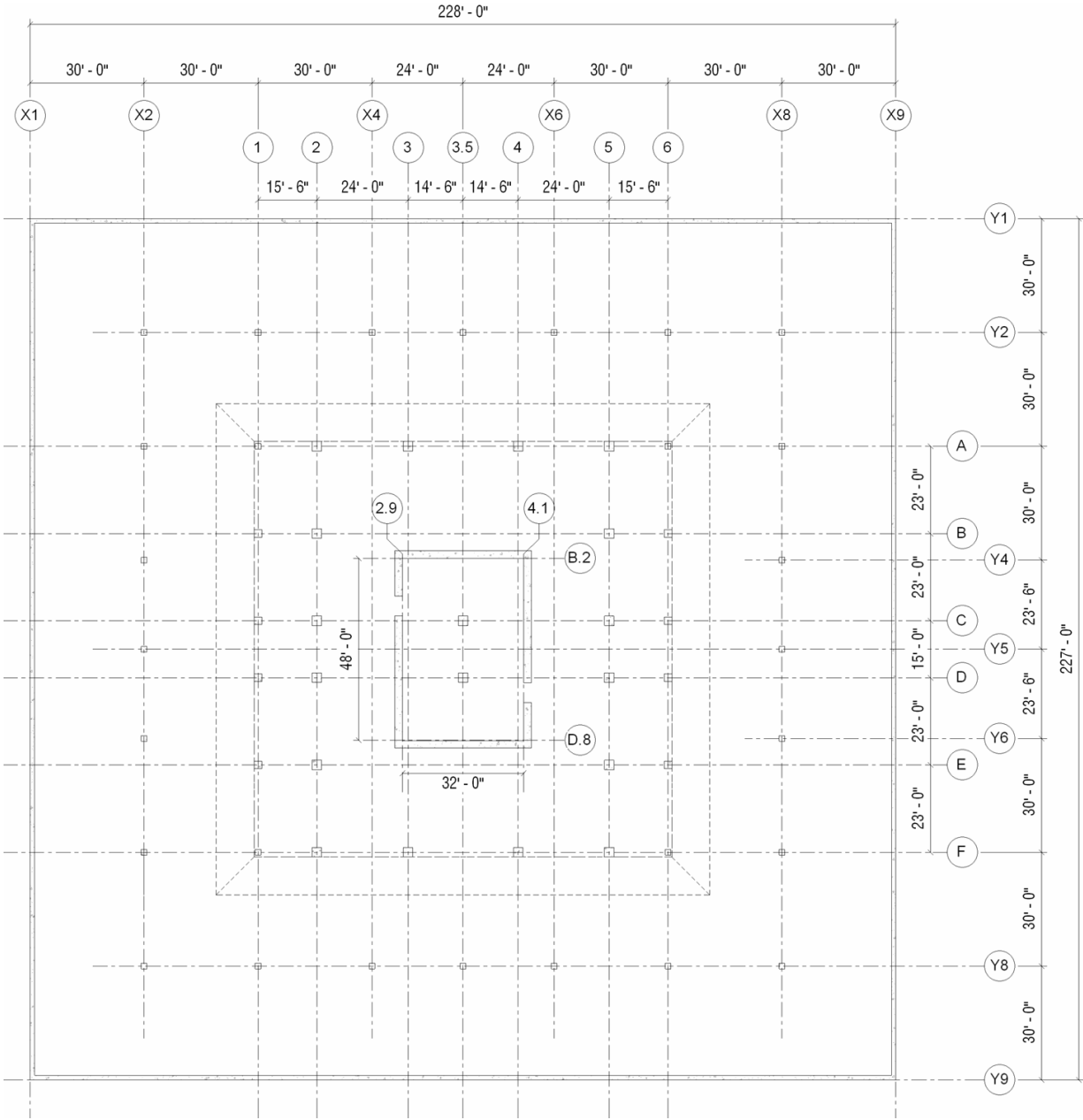

Figure 1. Building 1 Foundation Plan

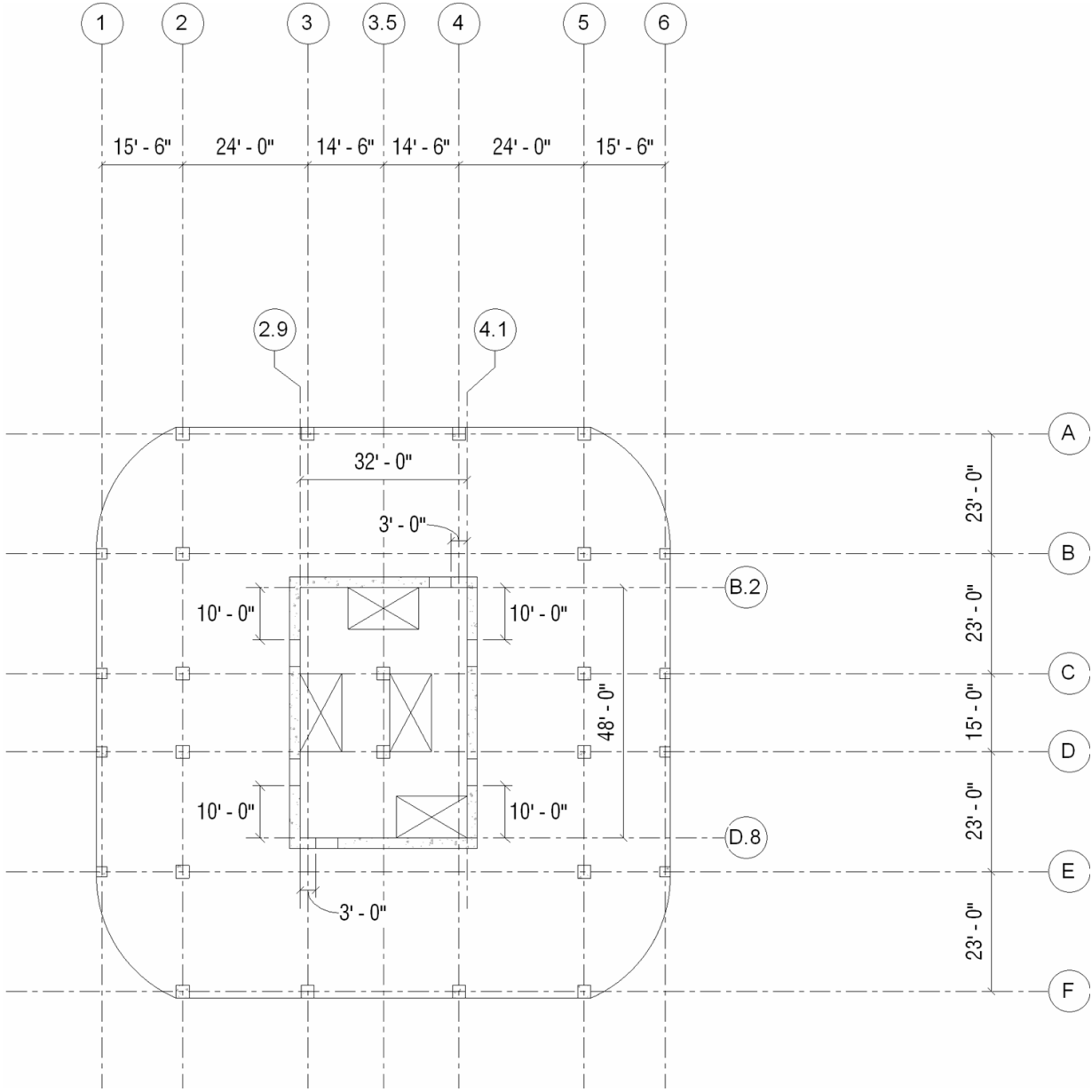

Figure 2. Building 1 Tower Plan

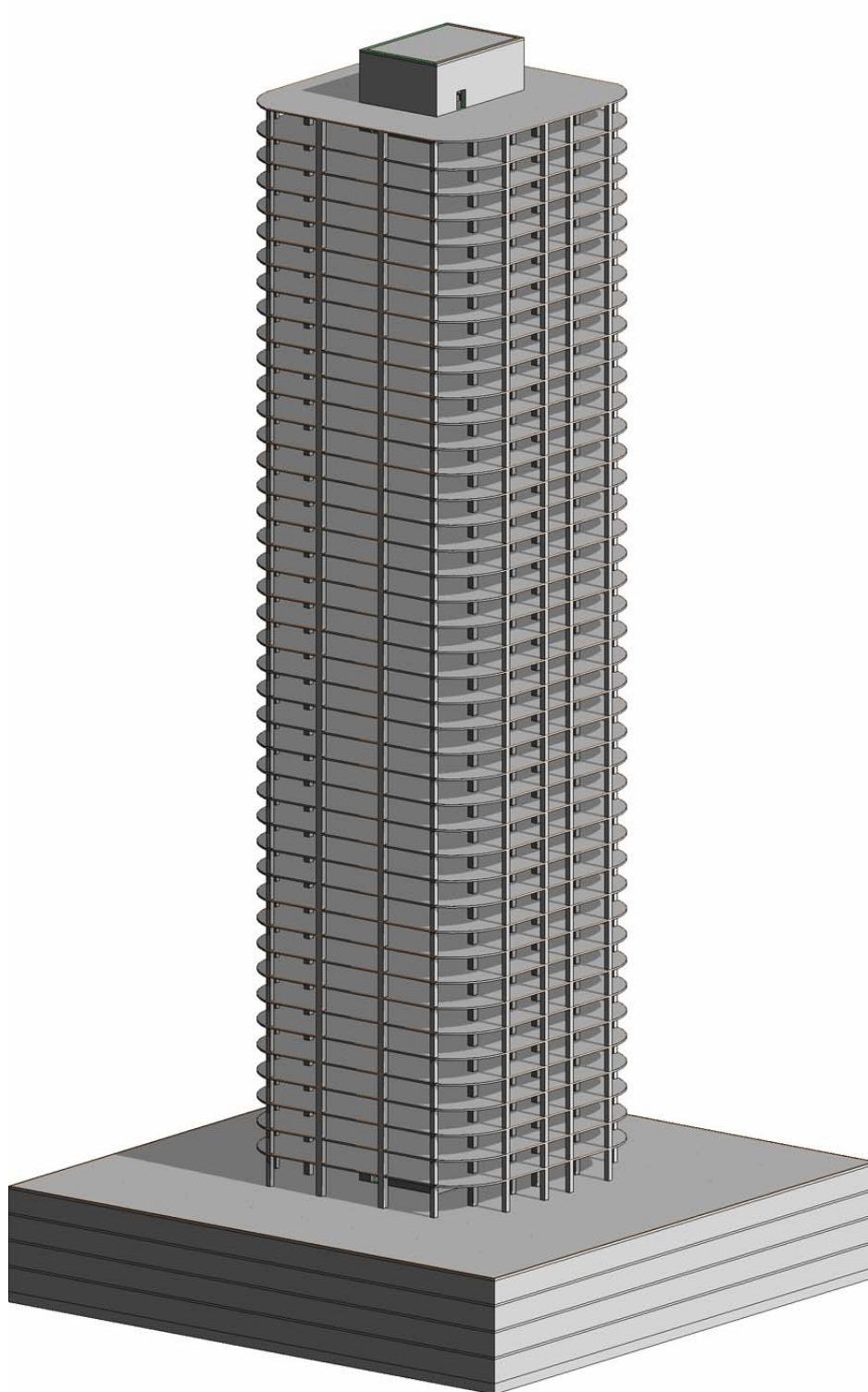

Figure 3. Building 1 Tower Isometric

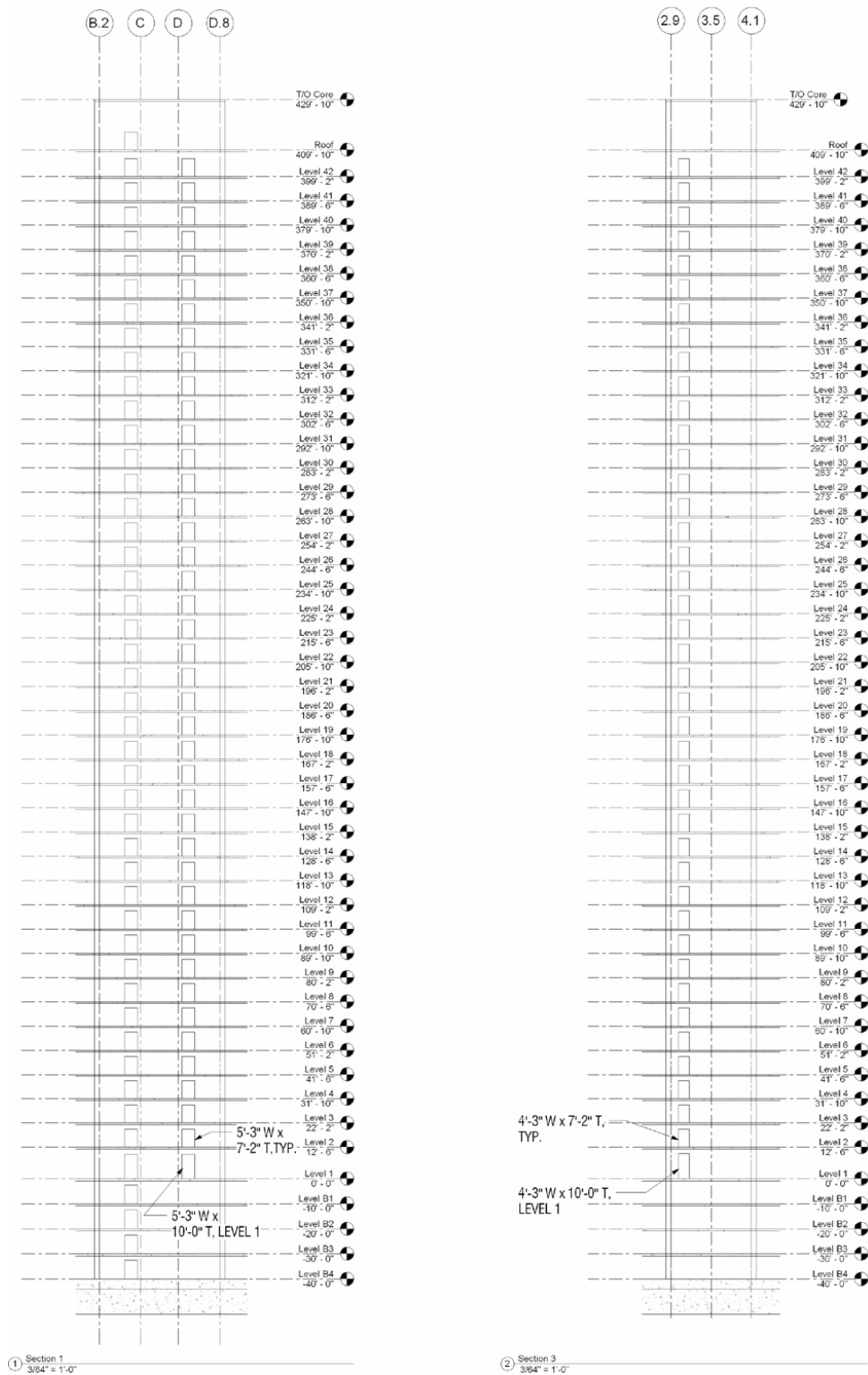

Figure 4. Building 1 Core Wall Elevations

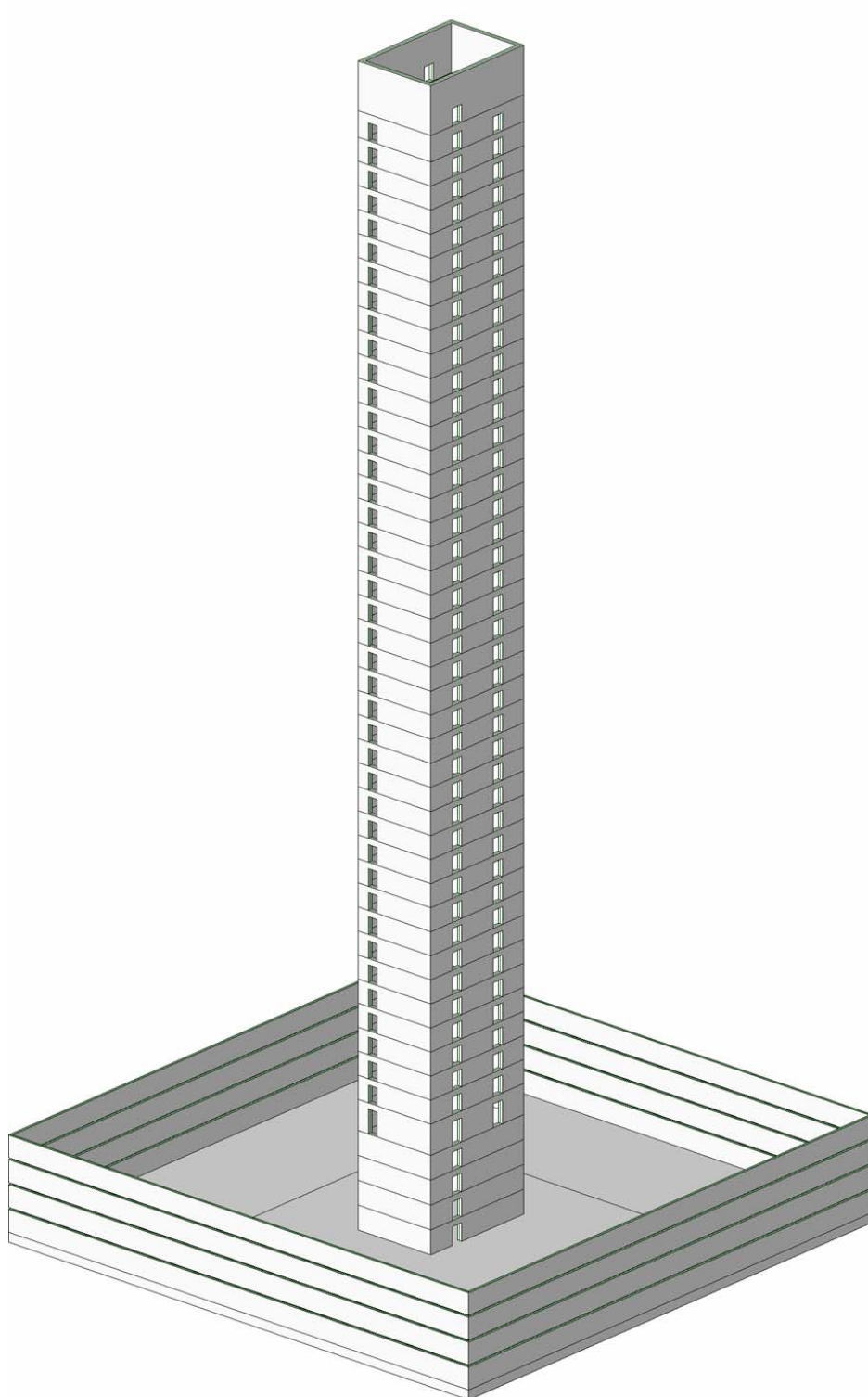

Figure 5. Building 1 Core Wall Isometric

ANALYSIS AND DESIGN COMPARISON OVERVIEW

Since the results of the three designs will be compared, it is important to note the differences in design approach taken for each of the three buildings. Comparison studies performed by others may not provide the expected results. The shaded cells in Table 1 highlight the primary differences between the three designs.

Table 1. Analysis and Design Approach Comparison

Topic	Building 1A Prescriptive Code Design	Building 1B LATBSDC PBD Design	Building 1C PEER TBI PBD Design
Minimum Strength	0.060 * 85% = 0.051W (ASCE Equation 12.8-6)	25-year MRI, 2.5% damped serviceability spectrum	43-year MRI, 2.5% damped serviceability spectrum
Elastic Computer Model	<ul style="list-style-type: none"> ▪ Specified material properties ▪ Gravity system <u>not</u> included ▪ Stiffness assumptions assume cracking at DBE level ("more cracked" model) 	<ul style="list-style-type: none"> ▪ Expected material properties ▪ Gravity system included ▪ Stiffness assumptions assume cracking at Service level ("less cracked" model) 	<ul style="list-style-type: none"> ▪ Expected material properties ▪ Gravity system included ▪ Stiffness assumptions assume cracking at Service level ("less cracked" model)
Model of Below-Grade Structure	Model extends to foundation mat including basement walls and below-grade slabs. Mass and mass moment-of-inertia are included in the model. Lateral resistance of the soil on the foundation walls is neglected.	Model extends to foundation mat including basement walls and below-grade slabs. Mass and mass moment-of-inertia are included in the model. Lateral resistance of the soil on the foundation walls is neglected.	Model extends to foundation mat including basement walls and below-grade slabs. Mass and mass moment-of-inertia are <u>not</u> included in the model. Lateral resistance of the soil on the foundation walls is neglected.

Topic	Building 1A Prescriptive Code Design	Building 1B LATBSDC PBD Design	Building 1C PEER TBI PBD Design
<p>Procedure Used to Provide Initial Design of Elements</p>	<p>Design followed the prescriptive provisions of the building code including the use of strength reduction factors and specified material properties.</p>	<ul style="list-style-type: none"> ▪ Story drift limited to 0.5% ▪ Coupling beams were designed using <u>specified</u> material strengths and <u>strength reduction factors in accordance with material codes</u>. No more than <u>20%</u> of the beams are allowed to have a demand-capacity ratio greater than 1.0 but less than 1.5. ▪ Core wall shear and flexure were designed using specified material strengths and strength reduction factors in accordance with material codes. All demand-capacity ratios less are than 1.0. 	<ul style="list-style-type: none"> ▪ Story drift limited to 0.5% ▪ Coupling beams were designed using <u>expected</u> material strengths and <u>strength reduction factors set to unity</u>. <u>100%</u> of the beams are allowed to have a demand-capacity ratio greater than 1.0 but less than 1.5. ▪ Core wall shear was designed using specified material strengths and strength reduction factors in accordance with material codes. All demand-capacity ratios are less than 1.0. ▪ For core wall flexure, where the axial load on a wall pier including EQ effect (P_u) is less than or equal to $0.3(f'_c)$ using expected material props, P-M-M interaction design considered expected material strengths and strength reduction factors set to unity. The wall piers were allowed to have a demand-capacity ratio greater than 1.0 but less than 1.5. Where P_u was greater than $0.3(f'_c)$, P-M-M interaction design considered specified material strengths and strength reduction factors in accordance with material codes. All demand-capacity ratios were less than 1.0.

Topic	Building 1A Prescriptive Code Design	Building 1B LATBSDC PBD Design	Building 1C PEER TBI PBD Design
Non-Linear Computer Model	Model created using similar techniques to Building 1B. Model includes gravity system approximation.	Non-linear model created as summarized in MKA's Non-Linear Response History Analysis Model Report.	Model created using similar techniques to Building 1B with updated element properties based on the design of Building 1C.
MCE-Level Hazard	MCE-level checks were not performed.	Seven earthquake records (original records) were used. The revised records were evaluated, but the design was not updated for the new results.	Seven earthquake records (revised records) were used.
MCE-Level Checks	MCE-level checks were not performed.	<ul style="list-style-type: none"> ▪ Ductile Actions and Drift: Mean demands were used. Capacities were calculated using expected material properties and strength reduction factors set to unity. ▪ Brittle Actions: 1.5 times the mean demands were used. Capacities were calculated using specified material properties and strength reduction factors set to unity. 	<ul style="list-style-type: none"> ▪ Ductile Actions and Drift: Mean demands were used. Capacities were calculated using expected material properties and strength reduction factors set to unity. ▪ Brittle Actions: 1.5 times the mean demands were used. Capacities were calculated using specified material properties and strength reduction factors set to unity.

BUILDING CODES

The following building and material codes were used for the design:

BUILDING CODE

- International Building Code, 2006 Edition (IBC 2006) with reference to Minimum Design Loads for Buildings and Other Structures by the American Society of Civil Engineers, 2005 Edition (ASCE 7).
- Alternative Seismic Design Criteria published by the Los Angeles Tall Buildings Structural Design Council (LATBSDC), 2008 Edition.
- Guidelines for Seismic Design of Tall Buildings developed by the Pacific Earthquake Engineering Research Center under its Tall Buildings Initiative, March 21, 2009 draft with August 4, 2009 updates.

MATERIAL CODES

- Reinforced Concrete: Building Code Requirements for Structural Concrete and Commentary by the American Concrete Institute, 2008 Edition (ACI 318).

LOADING CRITERIA

A summary of the project-specific loading criteria follows.

GRAVITY LOADING

The gravity loads listed in Table 2 are in addition to the self weight of the structure. The minimum loading requirements were taken from Table 4-1 of ASCE 7 as well as the loading criteria supplied by PEER. Live loads were reduced where permitted in accordance with Section 4.8 of ASCE 7. Loads are given in pounds per square foot (psf).

Table 2. Gravity Loads

Use	Live Loading	Superimposed Dead Loading
Parking Garage	40 (not reduced)	3
Level 1 Retail (under tower footprint)	100 (not reduced)	110
Level 1 Plaza (outside tower footprint)	100 (not reduced)	350
Exit Areas (assumed inside core walls only)	100 (not reduced)	28
Residential/Hotel (used for all elevated levels of the tower outside the core walls)	40	28
Mechanical/Electrical	0	100 kips at roof level only
Roof	25	28

In addition to these uniform slab loads, a perimeter dead load as shown in Table 3 was applied to the structure to account for the weight of the cladding system.

Table 3. Cladding Loads

Load Type	Load (psf)
Exterior Cladding (curtain wall)	15 psf (wall area)

WIND DESIGN CRITERIA

Wind loading is in accordance with the ASCE 7 requirements as shown in Table 4. It was determined that wind did not govern any portion of the design of Building 1.

Table 4. Wind Design Criteria

Parameter	Value
Basic Wind Speed, 3-second gust (V)	85 mph
Basic Wind Speed, 3-second gust (V), for serviceability wind demands based on a 10-year mean recurrence interval	67 mph
Exposure	B
Occupancy Category	II
Importance Factor (I_w)	1.0
Topographic Factor (K_{zt})	1.0
Enclosure Classification	Enclosed
Internal Pressure Coefficient (GC_{pi})	0.18
Mean Roof Height (h)	409'-10"



SEISMIC DESIGN CRITERIA

Seismic loads are in accordance with the ASCE 7 requirements as shown in Table 5. These code values were used only in the design of Building 1A.

Table 5. Seismic Design Criteria – Used for Building 1A Only

Parameter	Value
Building Latitude/Longitude	34.0495° N, 118.252° W
Occupancy Category	II
Importance Factor (I_a)	1.0
Mapped Spectral Acceleration	$S_s = 2.147$; $S_1 = 0.720$
Site Class	C
Site Class Coefficients	$F_o = 1.00$; $F_v = 1.30$
Spectral Response Coefficients	$S_{DS} = 1.145$; $S_{D1} = 0.521$
Seismic Design Category	D
Lateral System	Building Frame, Special Reinforced Concrete Shear Walls
Response Modification Coefficient (R)	6
Building Period (T_{code}), Section 12.8.2	$T_{code} = 2.55$ seconds (Based on $H = 409'-10"$)
C_s (Equation 12.8-2)	$C_s = \frac{S_{DS}}{(R/I)} = 0.19$
C_s^{max} (Equation 12.8-3)	$C_s^{max} = \frac{S_{D1}}{T_{code}(R/I)} = 0.034$
C_s^{min} (Equation 12.8-5, including ASCE 7 supplement 2)	$C_s^{min} = 0.044S_{DS}/I = 0.050$
C_s^{min} (Equation 12.8-6)	$C_s^{min} = \frac{0.5S_1}{R/I} = 0.060 \leftarrow \text{governs}$
Seismic Response Coefficient	$C_s = 0.060$
Seismic Weight, weight above Level 1	$W = 89,500$ kips
Design Base Shear	$V = 0.85C_sW = 0.05W = 4,565$ kips
Analysis Procedure Used	Modal Analysis Procedure

SEISMIC RESPONSE SPECTRA AND GROUND MOTIONS FOR NON-LINEAR RESPONSE HISTORY ANALYSIS (NLRHA)

Seismic response spectra and seven pairs of site-specific ground motions were provided by Mactec for this study. All spectra provided are at the ground surface level. Ground motions were provided as free-field motions (i.e., at the ground surface) and were spectrally matched to the Maximum Considered Earthquake (MCE) spectrum. All spectra and ground motions were applied to the lateral models at the level of the mat foundation.

The design spectra for the project, generated using the provisions of ASCE 7 -05, Section 21.3, are shown in Figure 6.

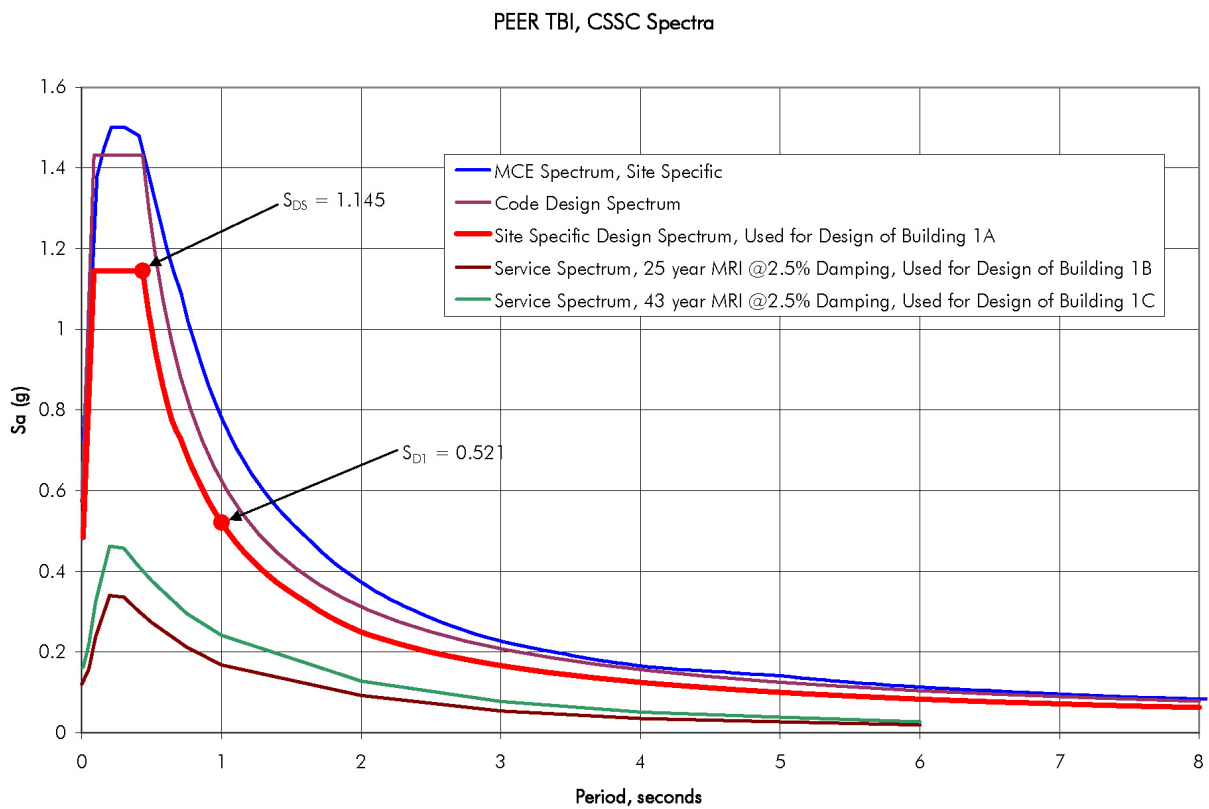



MATERIALS

The material properties used for the design are summarized in Tables 6 through 8. The modulus of elasticity for concrete was calculated using Equation 5-1 of ACI 363.

Table 6. Concrete Properties, Compressive Strength, and Modulus of Elasticity

Member	Nominal f'_c	Expected f'_c	Nominal E	Expected E
Basement Walls	5.0 ksi	6.5 ksi	3,830 ksi	4,225 ksi
Foundation Mats	6.0 ksi	7.8 ksi	4,100 ksi	4,530 ksi
Non-Post-Tensioned Beams and Slabs	5.5 ksi	7.2 ksi	3,970 ksi	4,395 ksi
Post-Tensioned Floor Slabs	5.5 ksi	7.2 ksi	3,970 ksi	4,395 ksi
Columns	8.0 ksi	10.4 ksi	4,580 ksi	5,080 ksi
Shear Walls	8.0 ksi	10.4 ksi	4,580 ksi	5,080 ksi

Table 7. Reinforcement and Post-Tensioning Properties

Standard	Nominal f_y	Expected f_y	Expected f_u
ASTM A615 Grade 60	60 ksi (non-seismic)	N/A	N/A
ASTM A706 Grade 60	60 ksi (seismic)	70 ksi	105 ksi
ASTM A615 Grade 75	75 ksi (used in coupling beams)	85 ksi	130 ksi

Table 8. Post-Tensioned Tendon Properties

Standard	Nominal f_u	Expected f_u
0.5-inch-diameter, 7-wire strand	$f_{pu} = 270$ ksi	N/A

DESIGN AND ANALYSIS SOFTWARE

The computer software employed for the analysis of the structure is listed in Table 9.

Table 9. Design and Analysis Software

Structural Analysis	Computer Software
Elastic Response Spectrum Analysis	ETABS, version 9
Non-linear Response History Analysis	CSI Perform-3D, version 4
Concrete Core Wall Flexural Design	PCA Column, version 4
Concrete Core Wall Moment Curvature Analysis	UC Fyber, version 2.4
Post-tensioned Slab Analysis	Ram-Concept, version 2.1
Reinforced Concrete Slab Analysis	SAFE, version 8

LOAD COMBINATIONS

BUILDING 1A LOAD COMBINATIONS

The design basis event was analyzed with modal response spectrum analysis. The load combinations shown in Table 10 follow the strength design load combinations listed in ASCE 7, Section 12.4.2.3.

Table 10. DBE Load Combinations

Identifier	Load Combinations
Load Combination 1	$(1.2+0.2S_{DS})D \pm \rho Q_E + f_1 L$
Load Combination 2	$(0.9-0.2S_{DS})D \pm \rho Q_E$

Where: D = dead load
L = reduced live load
 $f_1 = 0.5$ per ASCE 7, Section 12.4.2.3, Note 1
 ρ = the redundancy factor
 $0.2S_{DS}D = E_v$ per ASCE 7, Section 12.4.2.2
 $\rho Q_E = E_h$ per ASCE 7, Section 12.4.2.1

Seismic directional effects were considered as follows:

- $Q_{EX} = \pm 1.0 E_{hx} \pm 0.3 E_{hy} \pm T_{hx}$
- $Q_{EY} = \pm 0.3 E_{hx} \pm 1.0 E_{hy} \pm T_{hy}$

Where: E_{hx} and E_{hy} = earthquake forces in the primary structural directions, determined by spectral analysis
 T_{hx} and T_{hy} = accidental torsion per ASCE 7, Section 12.8.4.2 (forces in X and Y directions, respectively)

BUILDING 1B AND 1C SERVICEABILITY LOAD COMBINATION

The serviceability event was analyzed using a modal response spectrum analysis. Accidental torsion was not considered in this analysis, and one load combination was used, as shown in Table 11.

Table 11. Serviceability Load Combination

Identifier	Load Combination
Load Combination	$1.0D + 0.25L \pm 1.0E_{\text{service}}$

Where: D = dead load
L = unreduced live load
 E_{service} = serviceability response spectrum

Seismic directional effects were considered as follows:

- $E_{\text{service}} = \pm 1.0 E_{\text{service}_x} \pm 0.3 E_{\text{service}_y}$ and $\pm 0.3 E_{\text{service}_x} \pm 1.0 E_{\text{service}_y}$

BUILDING 1B AND 1C MCE LOAD COMBINATIONS

The NLRHA utilized one load combination for the MCE event, as shown in Table 12. This load combination was used for each of the seven ground motion records. Accidental torsion was not considered in this analysis.

Table 12. NLRHA Load Combination

Identifier	Load Combination
Load Combination	$1.0D + 0.25L + 1.0E$

Where: D = dead load
L = unreduced live load
E = earthquake load (ground motion records)
The ground motion records consist of two components. The components were not rotated to match the building axes.

LATERAL MODEL SUMMARY

ELASTIC MODELS

Complete, three-dimensional elastic computer models for each building were analyzed using ETABS. The models included the core walls, ground-level diaphragm, below-grade diaphragms, and basement walls. The diaphragms and walls were modeled using shell elements. The coupling beams were modeled using frame elements. Openings through the core walls were modeled with separate wall elements coupled together with concrete beams.

The elastic model was used for both the code-level design of Building 1A and the serviceability analysis of Buildings 1B and 1C. The stiffness parameters for the various elements were varied in each of the models. Table 13 summarizes the stiffness assumptions in the computer models.

For the serviceability analyses only, slab outrigger effects were modeled using wide, shallow beams connecting the core walls to lumped concrete columns in the ETABS model. The modeling approach used for the slab outrigger beams is shown in Figure 7.

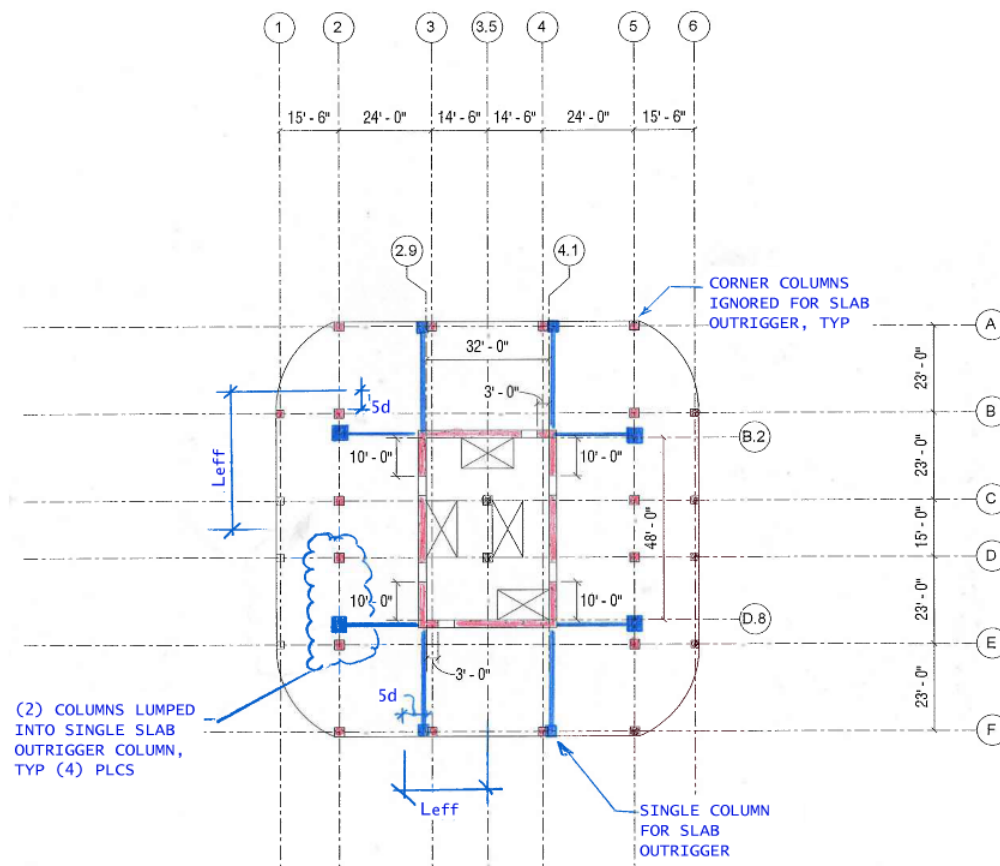

Figure 7. Slab Outrigger Modeling Approach

Stiffness

The stiffness assumptions used vary for each computer model based on the expected demand level. A summary of stiffness assumptions is shown in Table 13.

Table 13. Computer Model Stiffness Assumptions

Concrete Element	Serviceability Analysis and Wind – All Buildings	Code-Level Analysis – Building 1A Only	MCE-Level Non-Linear Models – All Buildings
Specified vs. Expected Concrete Strength	Expected concrete strength	Specified concrete strength	Expected concrete strength
Core Walls/Shear Walls	Flexural – 0.9lg Shear – 1.0A	Flexural – 0.6lg Shear – 1.0A	Refer to non-linear model summary
Basement Walls	Flexural – 1.0lg Shear – 1.0A	Flexural – 0.8lg Shear – 0.8A	Flexural – 0.8lg Shear – 0.8A
Coupling Beams	Flexural – 0.5lg Shear – 1.0A	Flexural – 0.2lg Shear – 1.0A	Refer to non-linear model summary
Ground Level Diaphragm	Flexural – 0.5lg Shear – 0.8A	Flexural – 0.25lg Shear – 0.5A	Flexural – 0.25lg Shear – 0.25A
Basement Diaphragms	Flexural – 0.5lg Shear – 0.8A	Flexural – 0.25lg Shear – 0.5A	Flexural – 0.25lg Shear – 0.25A
Concrete Columns	Flexural – 1.0lg Shear – 1.0A Axial – 1.0A	Not included in code design	Refer to non-linear model summary
Outrigger Slabs	Flexural – 0.35lg Shear – 1.0A	Not included in code design	Refer to non-linear model summary

Soil Structure Interaction Assumptions

Design spectra were applied to all computer models at the level of the top of the mat foundation. The flexibility of the subgrade and mat foundation was ignored, and the model was "fixed" at the top of the mat. Vertical and horizontal supports with no rotational restraints were assigned to all of the nodes of the model at the foundation level. The lateral resistance and damping effects of the soil on the sides of the basement walls were neglected in all models.

NON-LINEAR MODELS

Non-linear verification models were built in CSI Perform-3D for each building. The models include inelastic member properties for elements that are anticipated to be loaded beyond their elastic limits. These include the coupling beams, core wall flexural behavior, and "slab-beams" to account for any outrigger effect of the flat slabs. Elements that are assumed to remain elastic were modeled with elastic member properties. These include core wall shear behavior, diaphragm slabs, columns, and basement walls.

A detailed description of the non-linear modeling assumptions is included in a separate report entitled "Non-Linear Response History Analysis Model Report".

ACCEPTANCE CRITERIA

Acceptance criteria were required for the performance-based designs of Buildings 1B and 1C. The acceptance criteria for each of the two demand levels evaluated are listed in Tables 14 and 15.

SERVICEABILITY ANALYSIS

Table 14. Serviceability Acceptance Criteria

Item	Value
Story Drift	0.5%
Coupling Beams	Shear strength to remain essentially elastic
Core Wall Flexure	Remains essentially elastic
Core Wall Shear	Remains elastic
Slab Outrigger Beams	End moment to remain essentially elastic
Columns	Remains elastic

Acceptance criteria related to essentially elastic behavior for ductile elements in Buildings 1B and 1C were slightly different. A comparison can be found in Table 1 of this report.

NLRHA ACCEPTANCE CRITERIA

The following acceptance criteria were selected for Collapse Prevention performance under the MCE-level demand.

Table 15. NLRHA Acceptance Criteria

Item	Value
Story Drift	3% under MCE, taken as the average of seven response history results.
Coupling Beam Rotation	0.06 radian rotation limit, taken as the average of seven response history results.
Core Wall Reinforcement Axial Strain	Rebar tensile strain = 0.05 in tension and 0.02 in compression, taken as the average of seven response history results.
Core Wall Concrete Axial Strain	Fully Confined Concrete Compression Strain = 0.015, taken as the average of seven response history results.
Core Wall Shear	Verification performed for elastic behavior.
Slab Outrigger Beams	Included to study impact to core and column only. The performance of the moment hinges was not specifically reviewed.
Columns	Increases in column axial demands were reviewed.

The MCE-level acceptance criteria are summarized below:

- Ductile Actions and Drift: Mean demands were used. Capacity was calculated using expected material properties and strength reduction factors set to 1.0.
- Brittle Actions: 1.5 times the mean demands were used. Capacity was calculated using specified material strengths and strength reduction factors set to 1.0.

DESIGN SUMMARY

BUILDING 1

The gravity column sizes determined for all three buildings are summarized in Table 16. While rectangular columns would be expected in this type of building, square columns were selected for simplicity.

Table 16. Column Sizes

Column Mark	Levels	Size	Column Marks
D/3.5	Level 34 – Roof Level 22 – 34 Level 12 – 22 Fdn – Level 12	18"×18" 21"×21" 25"×25" 30"×30"	
D/5	Level 34 – Roof Level 22 – 34 Level 12 – 22 Fdn – Level 12	18"×18" 19"×19" 24"×24" 29"×29"	
D/6	Level 34 – Roof Level 22 – 34 Level 12 – 22 Fdn – Level 12	18"×18" 18"×18" 18"×18" 24"×24"	
E/5	Level 34 – Roof Level 22 – 34 Level 12 – 22 Fdn – Level 12	18"×18" 22"×22" 26"×26" 33"×33"	
E/6	Level 34 – Roof Level 22 – 34 Level 12 – 22 Fdn – Level 12	18"×18" 18"×18" 19"×19" 26"×26"	
F/4	Level 34 – Roof Level 22 – 34 Level 12 – 22 Fdn – Level 12	18"×18" 21"×21" 26"×26" 34"×34"	
F/5	Level 34 – Roof Level 22 – 34 Level 12 – 22 Fdn – Level 12	18"×18" 18"×18" 21"×21" 28"×28"	

DESIGN COMPARISON RESULTS

Key values from the design and selected element sizes are included in Table 17.

Table 17. Building 1 Comparison Results

	Building 1A	Building 1B	Building 1C
Code/Service EQ Base Shear (kips)	$V_x = 4,581$ (code) $V_y = 4,581$	$V_x = 5,013$ (service EQ) $V_y = 6,018$	$V_x = 6,686$ (service EQ) $V_y = 8,151$
Code/Service EQ Overturning Moment (kip-ft)	$M_y = 587,000$ (code) $M_x = 697,000$	$M_y = 591,000$ (service EQ) $M_x = 921,000$	$M_y = 892,000$ (service EQ) $M_x = 1,371,000$
MCE Base Shear (kips) Average of 7 EQs	—	$V_x = 13,718$ $V_y = 13,899$	$V_x = 13,025$ $V_y = 12,449$
MCE Overturning Moment (kip-ft) Average of 7 EQs	—	$M_y = 1,629,000$ $M_x = 1,227,000$	$M_y = 1,504,000$ $M_x = 1,221,000$
Core Wall Thicknesses (inches)	Grade – Lvl 25: 24 Lvl 25 – Roof: 21	Grade – Lvl 13: 28 (E-W) 32 (N-S) Lvl 13 – Lvl 31: 24 Lvl 31 – Roof: 21	Grade – Lvl 13: 32 (E-W) 36 (N-S) Lvl 13 – Lvl 31: 24 Lvl 31 – Roof: 21
Period (seconds) in ETABS Model	$T_1 = 6.7$ $T_2 = 4.8$ $T_T = 2.6$	$T_1 = 4.0$ $T_2 = 3.0$ $T_T = 1.5$	$T_1 = 4.0$ $T_2 = 3.0$ $T_T = 1.5$
Period (seconds) in Perform3D Model	$T_1 = 5.0$ $T_2 = 3.8$ $T_T = 2.4$	$T_1 = 4.2$ $T_2 = 3.4$ $T_T = 2.3$	$T_1 = 4.0$ $T_2 = 3.2$ $T_T = 2.2$
Maximum Story Drift (Service)	—	$\delta_x = 0.25\%$ $\delta_y = 0.20\%$	$\delta_x = 0.35\%$ $\delta_y = 0.28\%$
Maximum Story Drift (MCE)	$\delta_x = 1.1\%$ $\delta_y = 0.8\%$ Ref: Section 12.8.6	$\delta_x = 2.0\%$ $\delta_y = 1.3\%$ Average of 7 EQs	$\delta_x = 1.8\%$ $\delta_y = 1.1\%$ Average of 7 EQs

Figures 8 and 9 compare the shear and overturning moment demands on the three buildings.

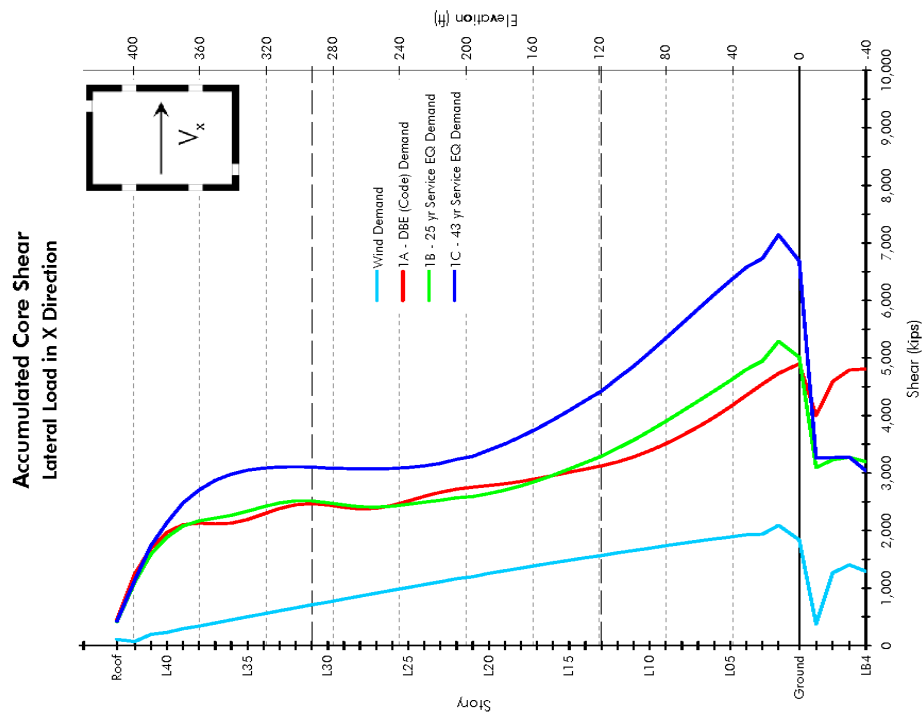
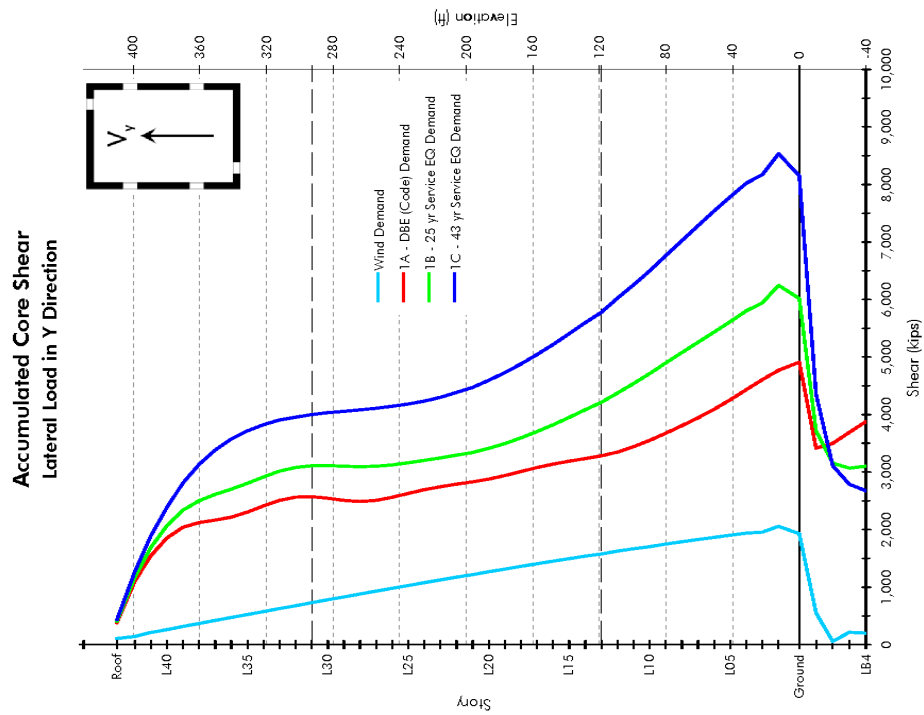

Figure 8. Core Wall Shear Force Comparison

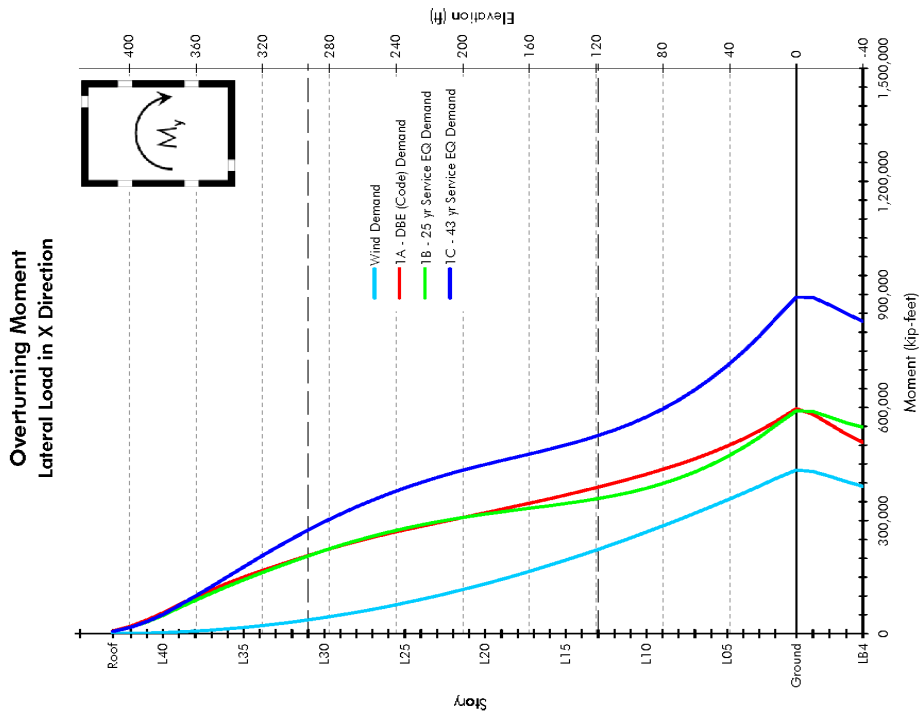
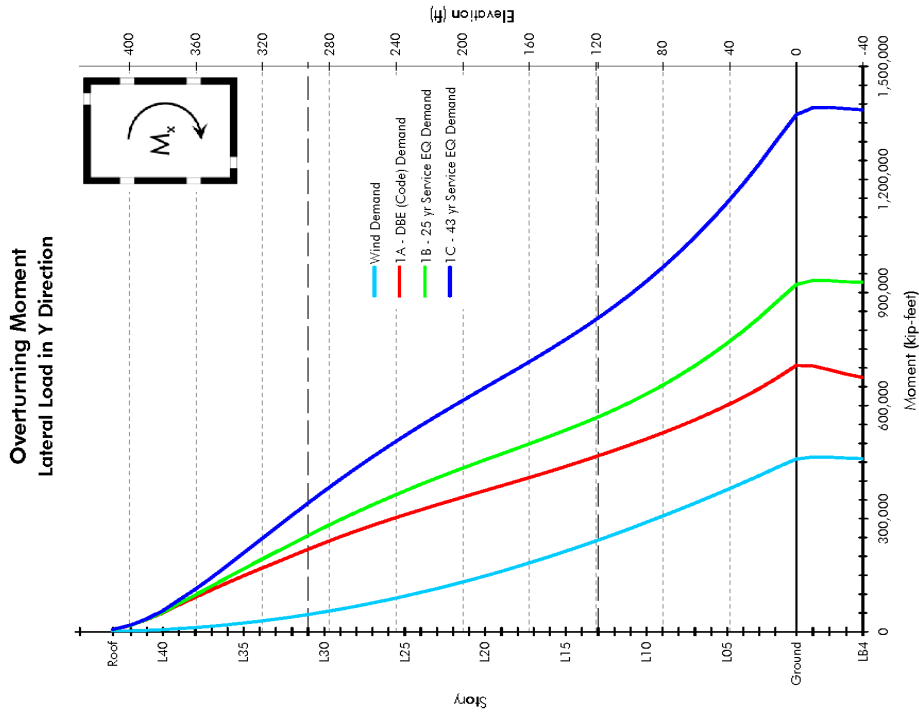

Figure 9. Core Wall Overturning Moment Comparison

The design of the coupling beams varied the most between the three different analyses. Figures 10 to 12 compare the rebar selected for each design.

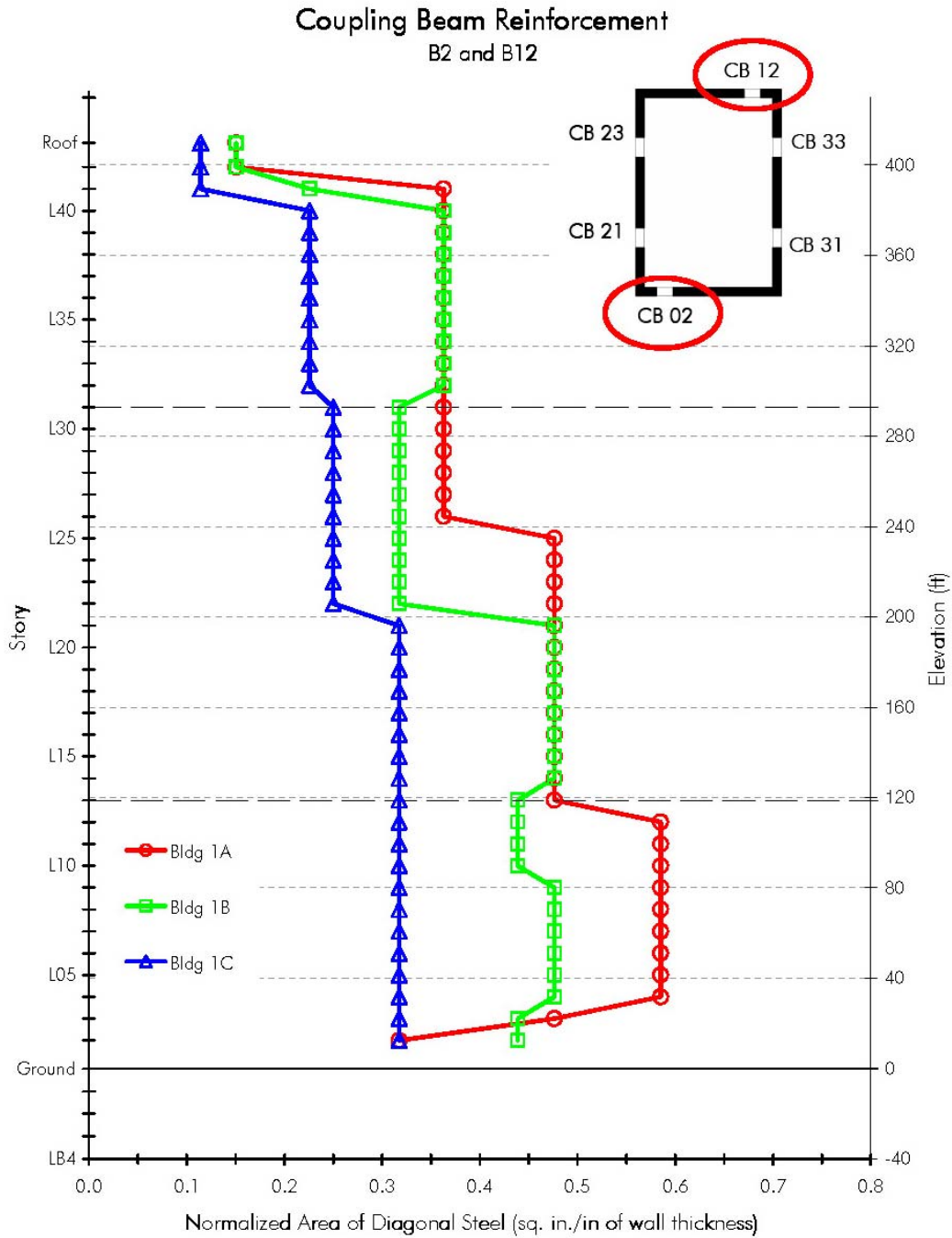

Figure 10. Coupling Beam Reinforcement Comparison

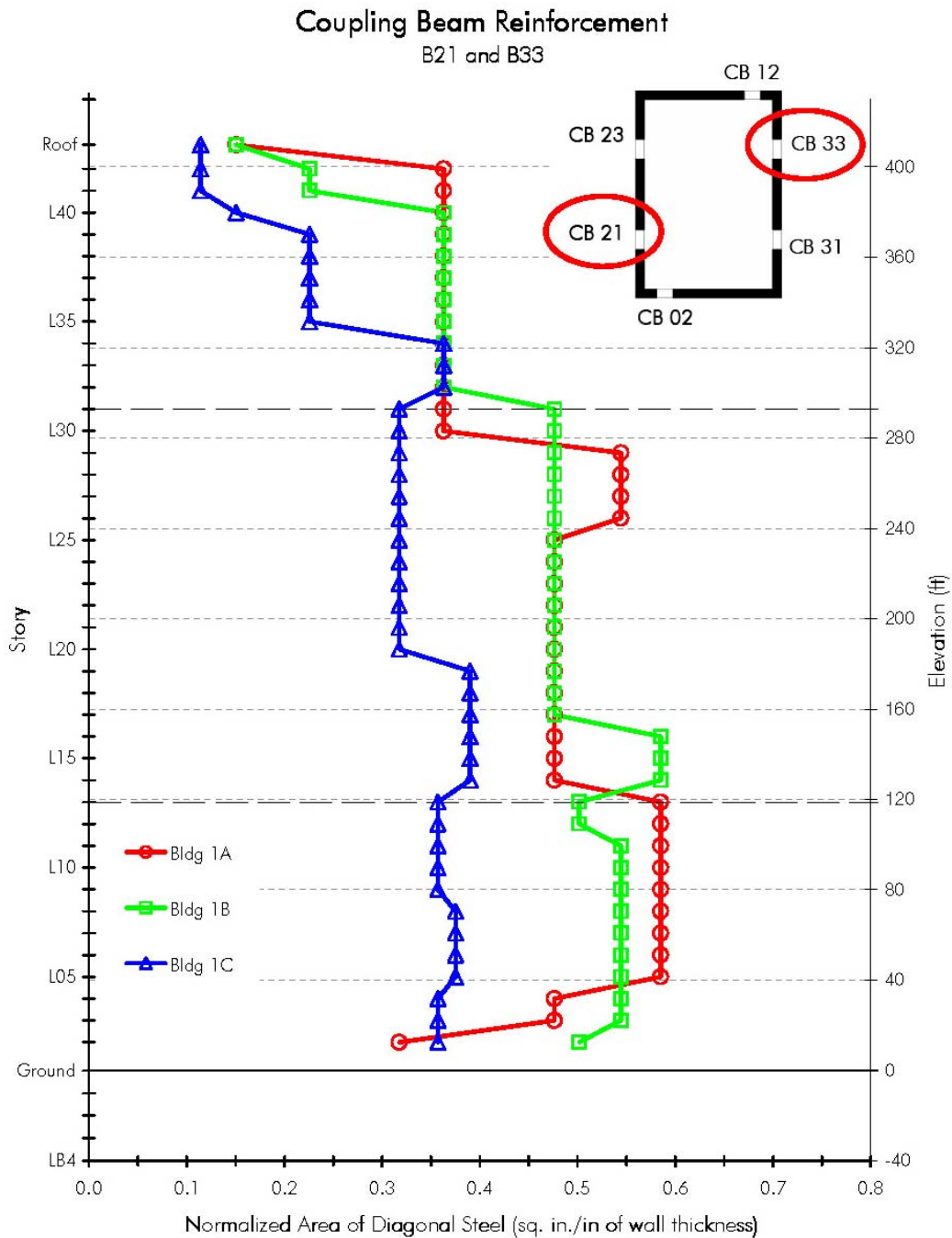

Figure 11. Coupling Beam Reinforcement Comparison

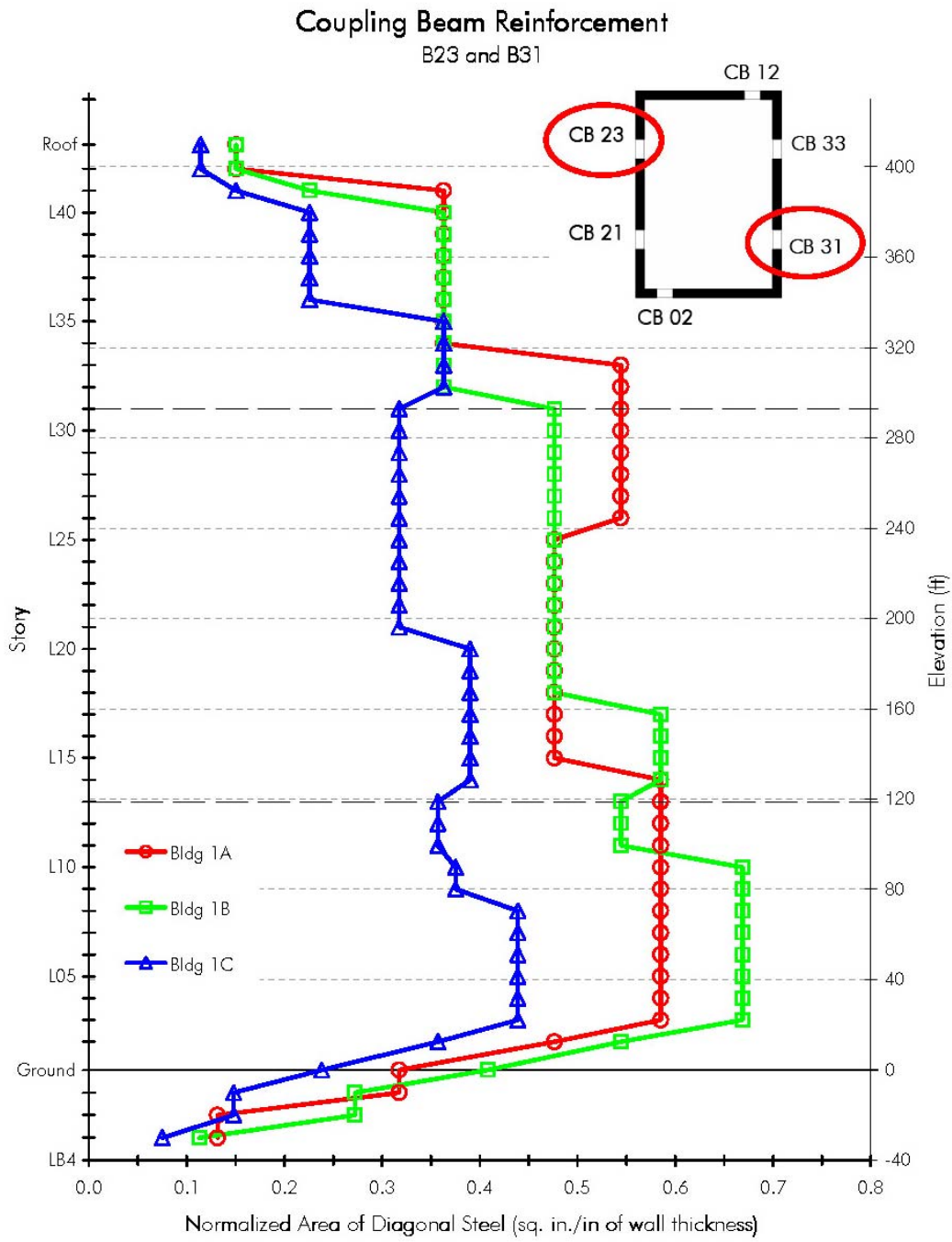

Figure 12. Coupling Beam Reinforcement Comparison

Comparisons of the vertical and horizontal reinforcing distributions that resulted from the three designs are illustrated in Figures 13 through 20.

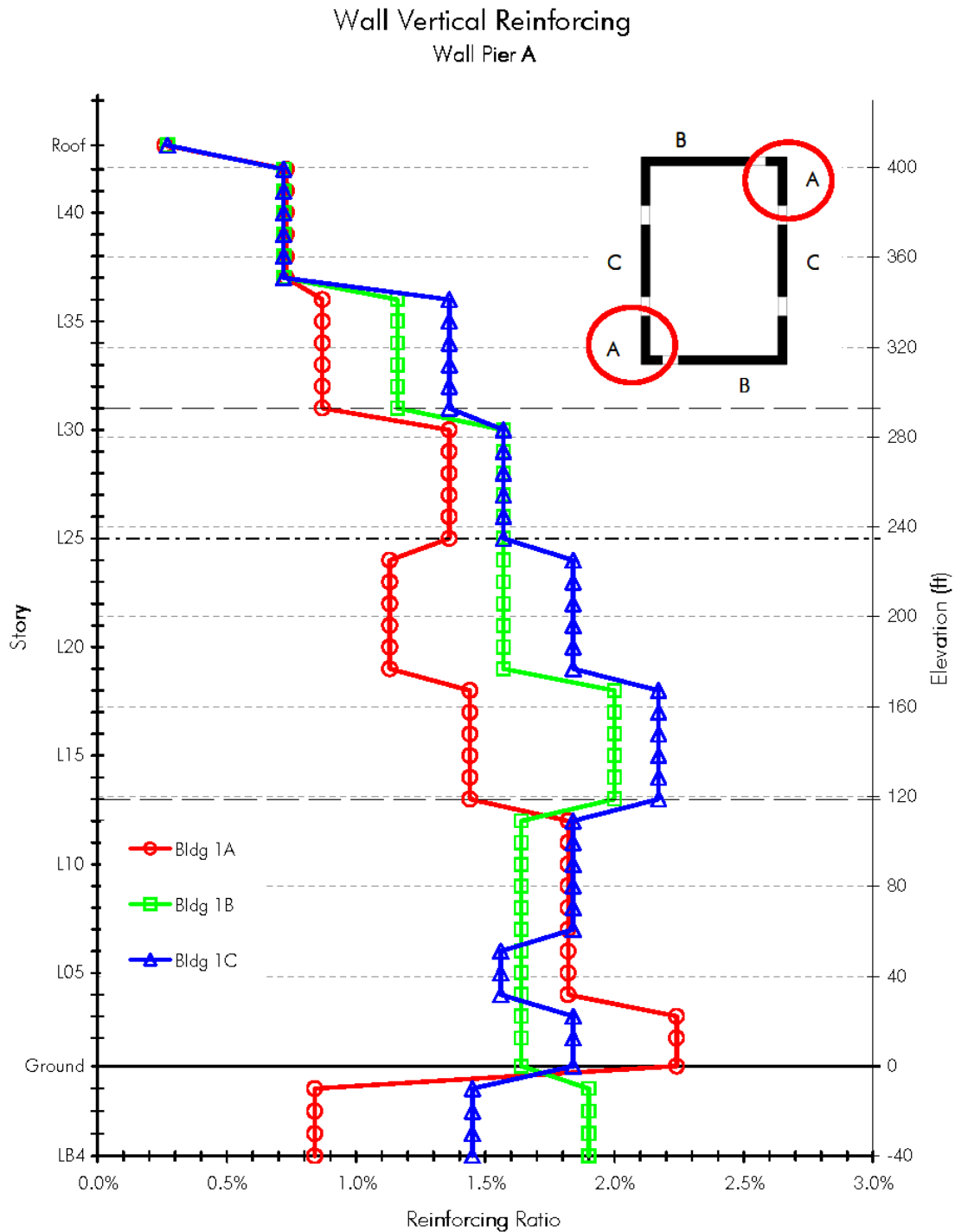

Figure 13. Wall Vertical Reinforcing Comparison

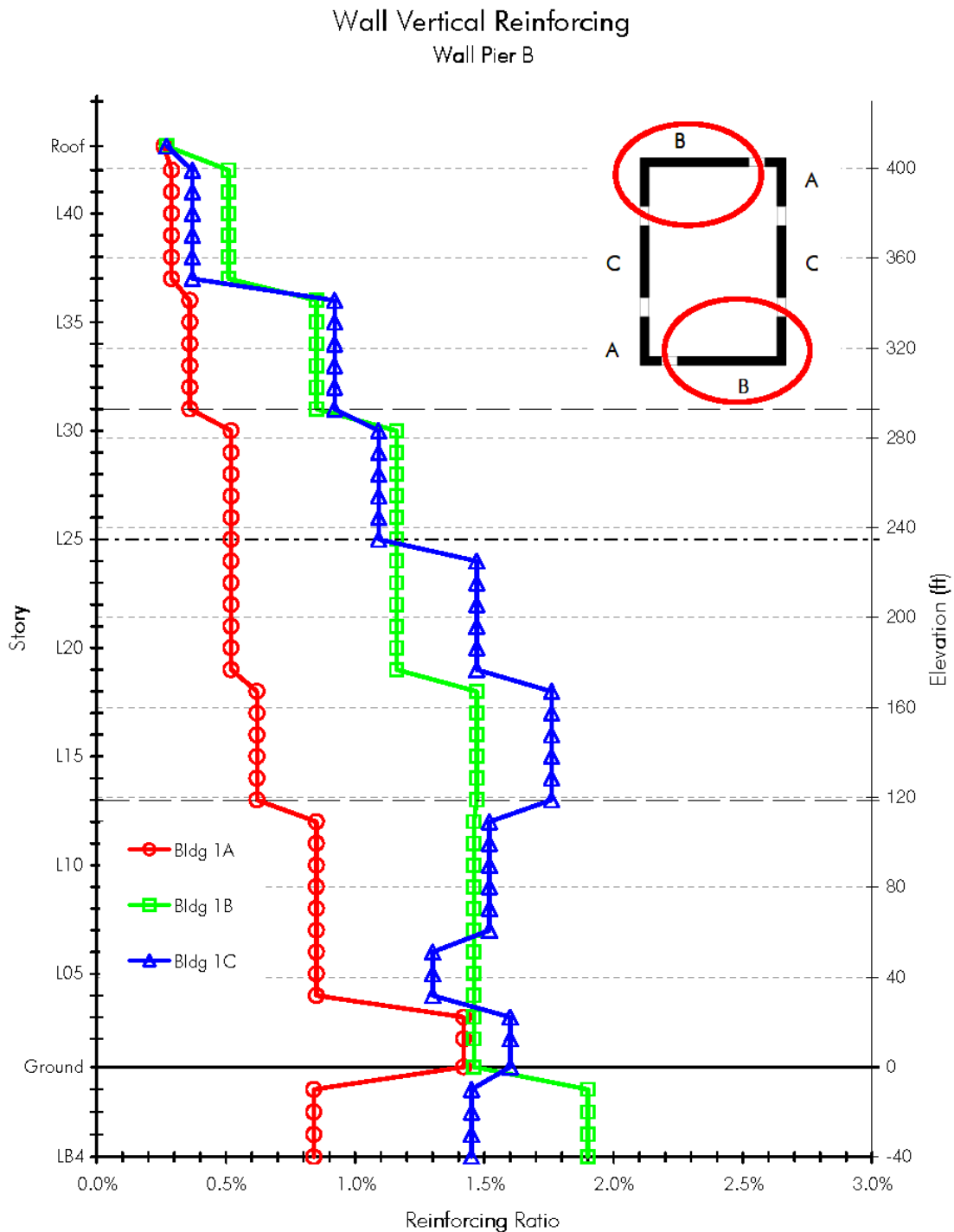

Figure 14. Wall Vertical Reinforcing Comparison

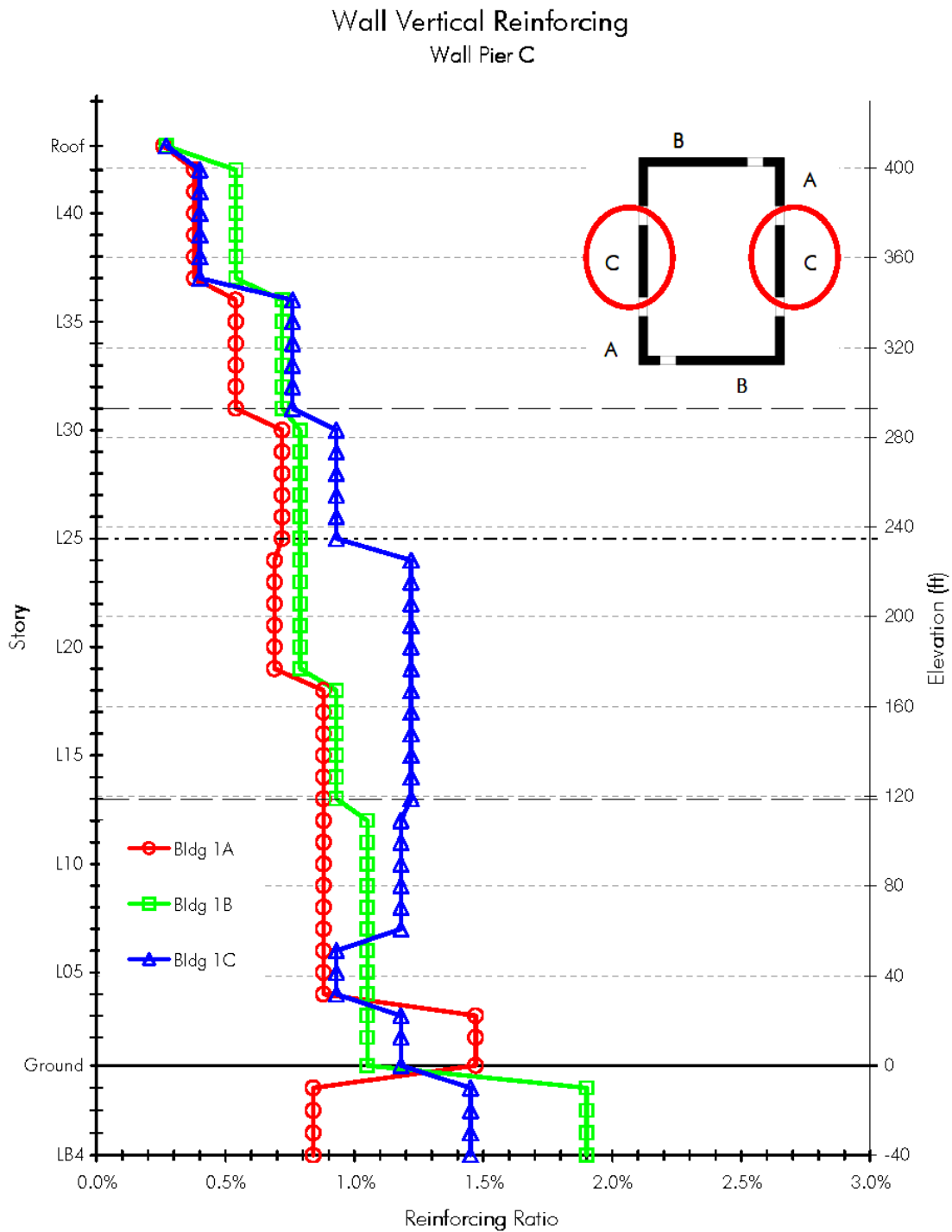

Figure 15. Wall Vertical Reinforcing Comparison

Wall Horizontal Reinforcing Wall Piers 01 & 13

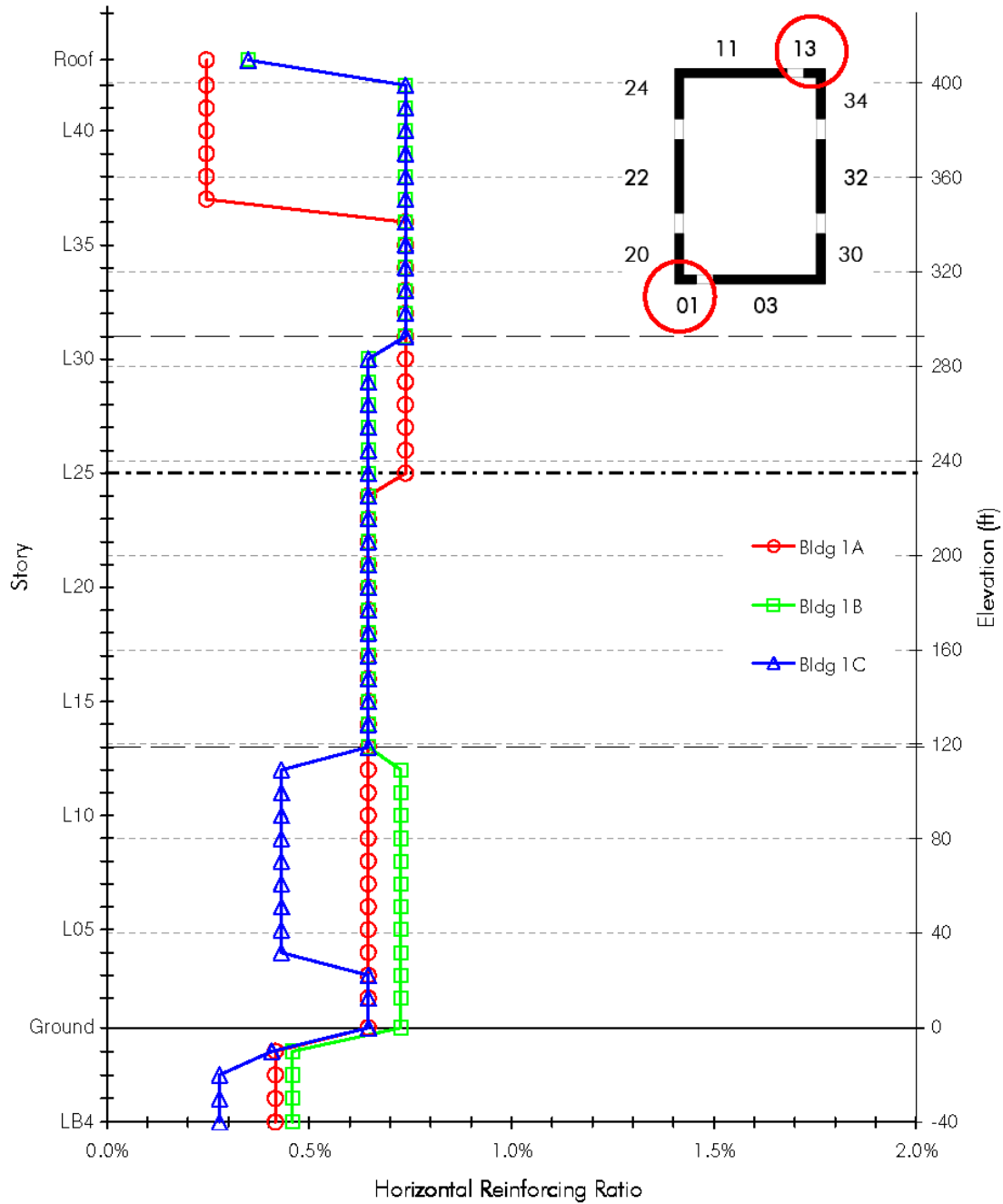

Figure 16. Wall Horizontal Reinforcing Comparison

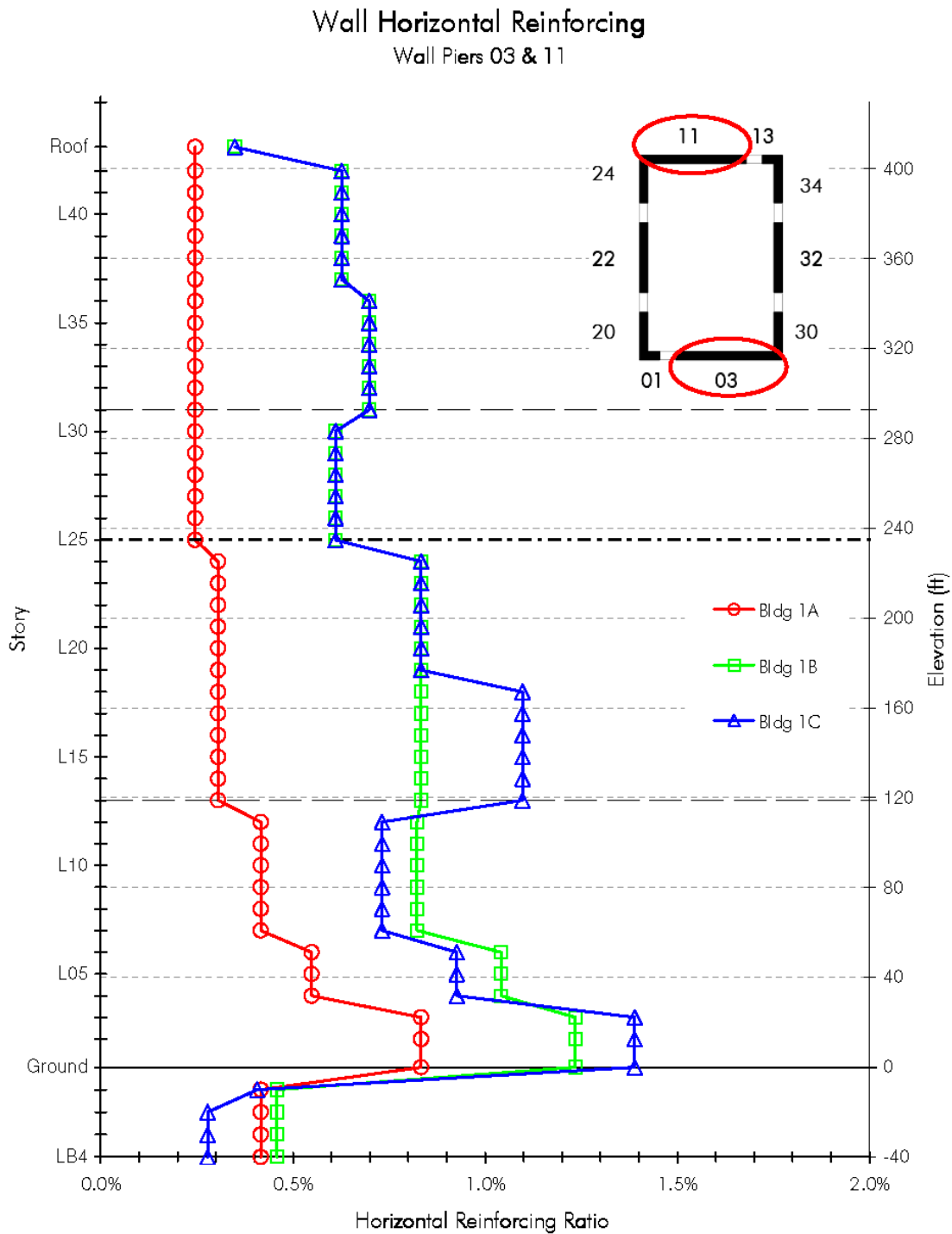

Figure 17. Wall Horizontal Reinforcing Comparison

Wall Horizontal Reinforcing Wall Piers 20 & 34

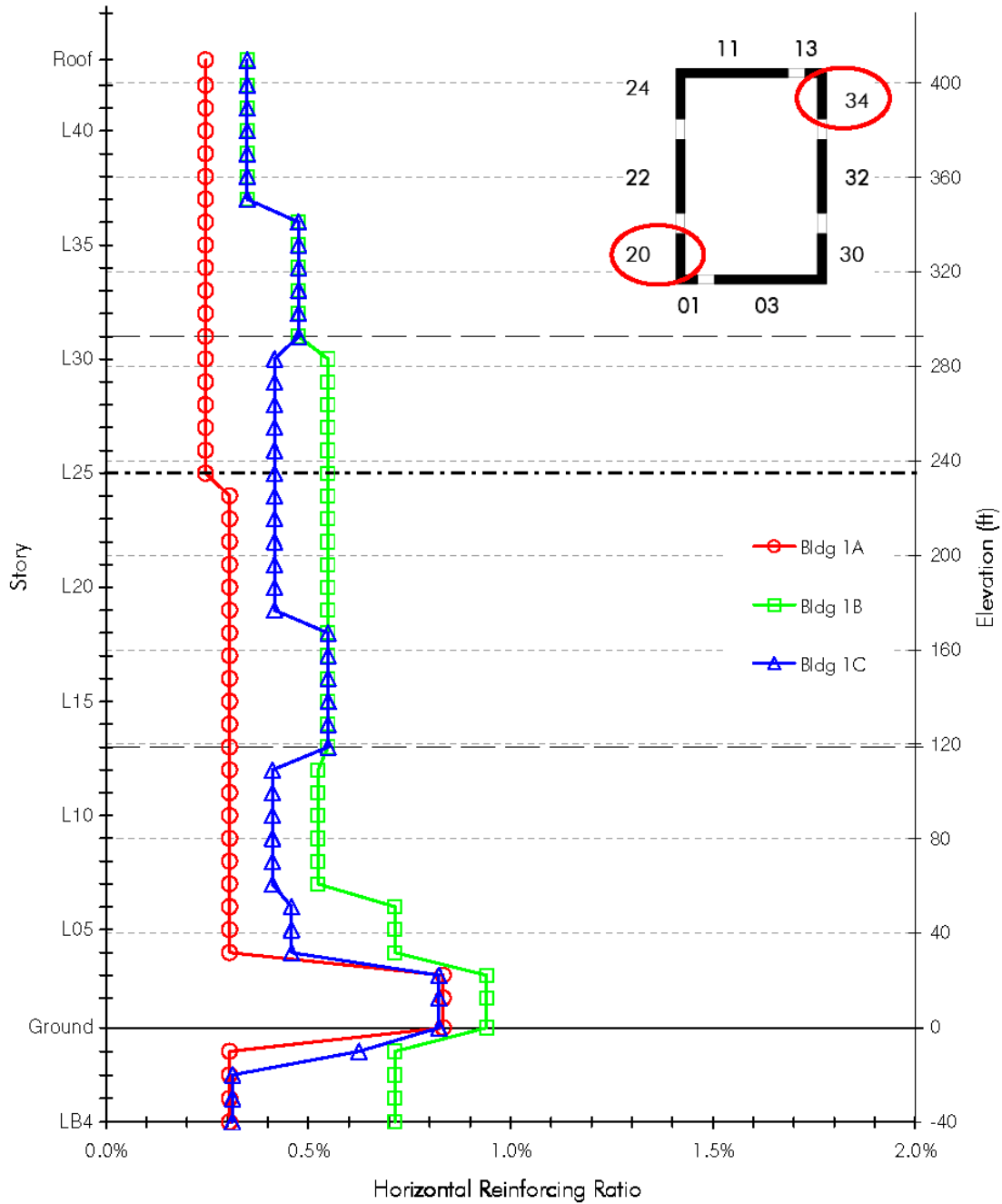

Figure 18. Wall Horizontal Reinforcing Comparison

Wall Horizontal Reinforcing Wall Piers 22 & 32

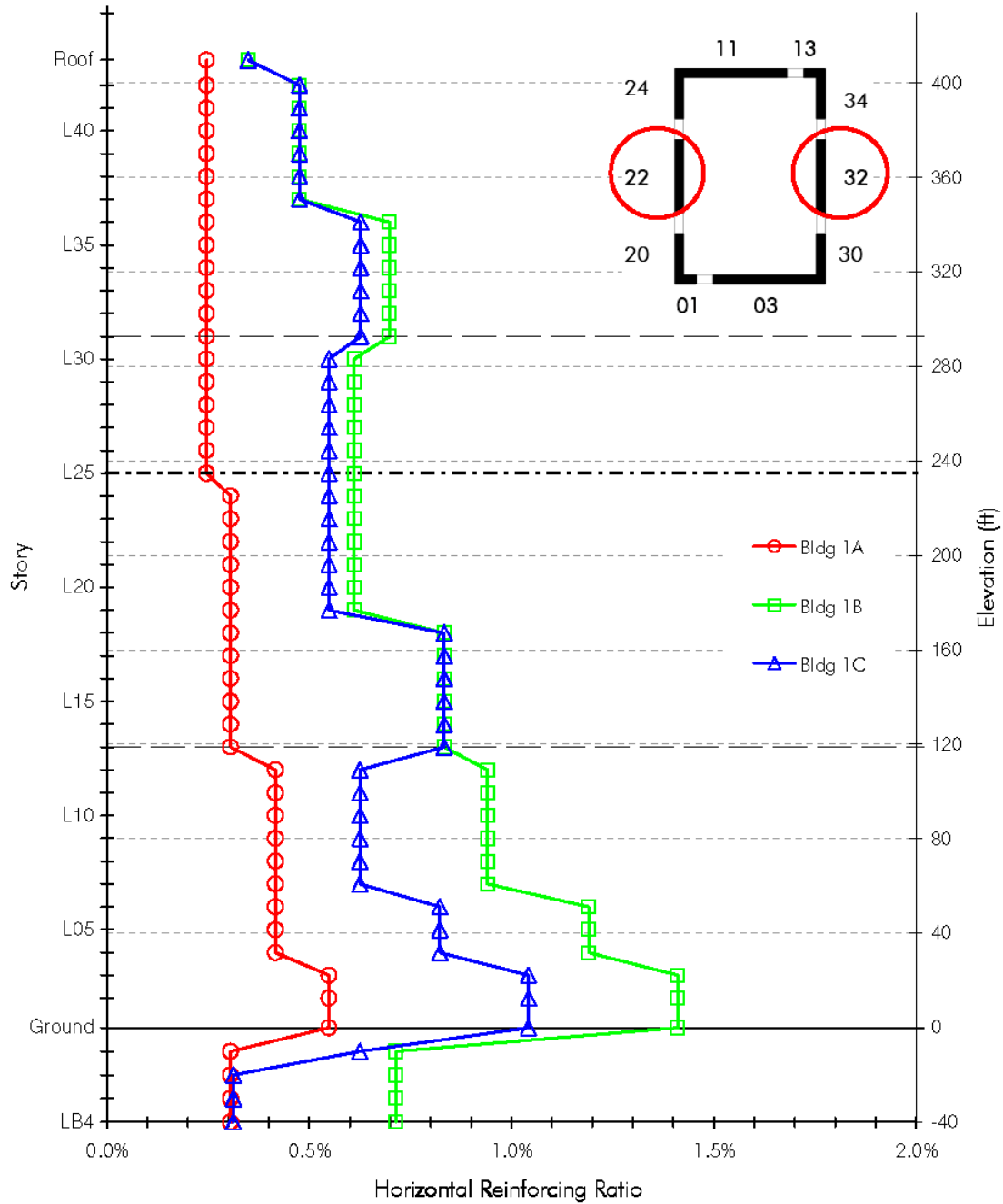

Figure 19. Wall Horizontal Reinforcing Comparison

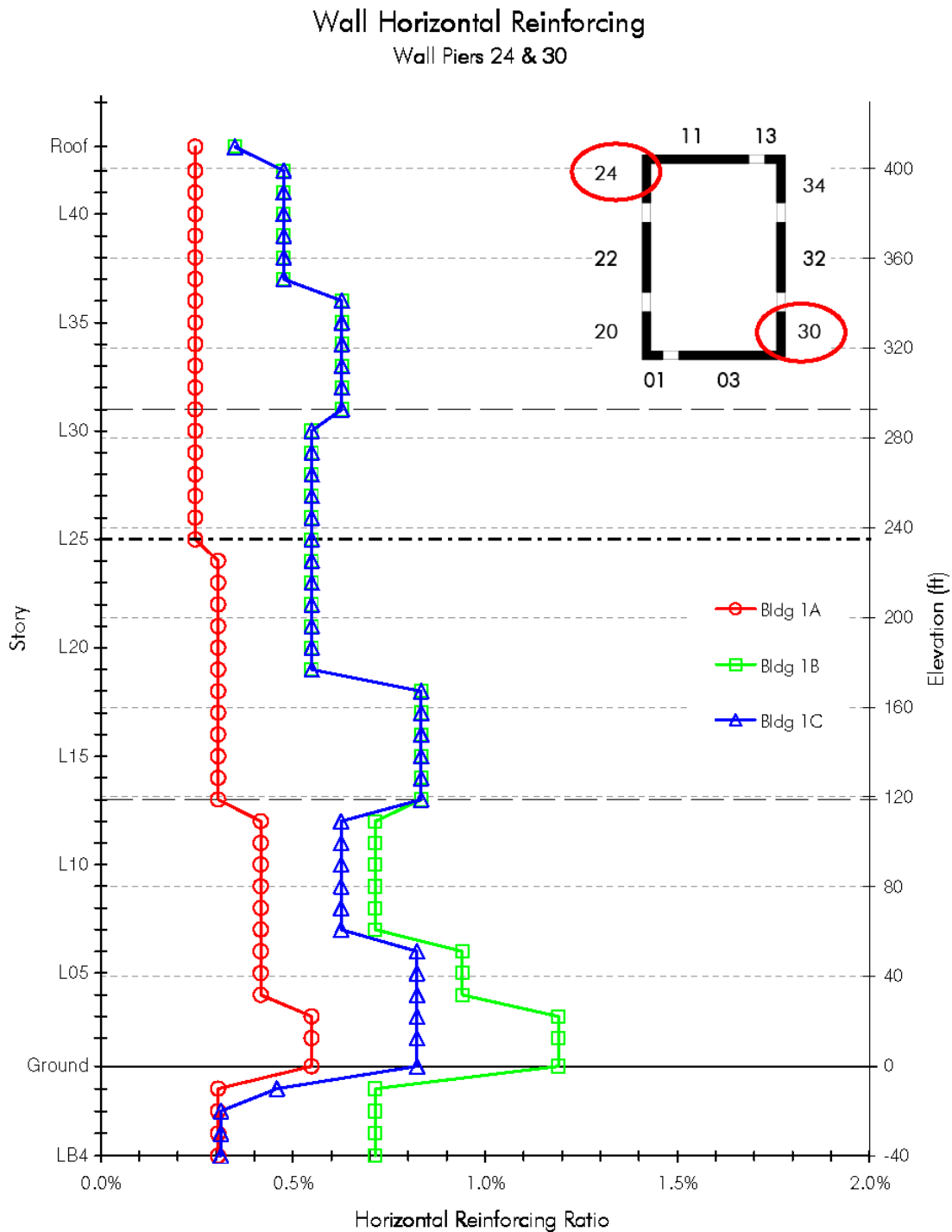

Figure 20. Wall Horizontal Reinforcing Comparison

Figures 21 and 22 compare the MCE shear force and overturning moment demands for Buildings 1B and 1C.

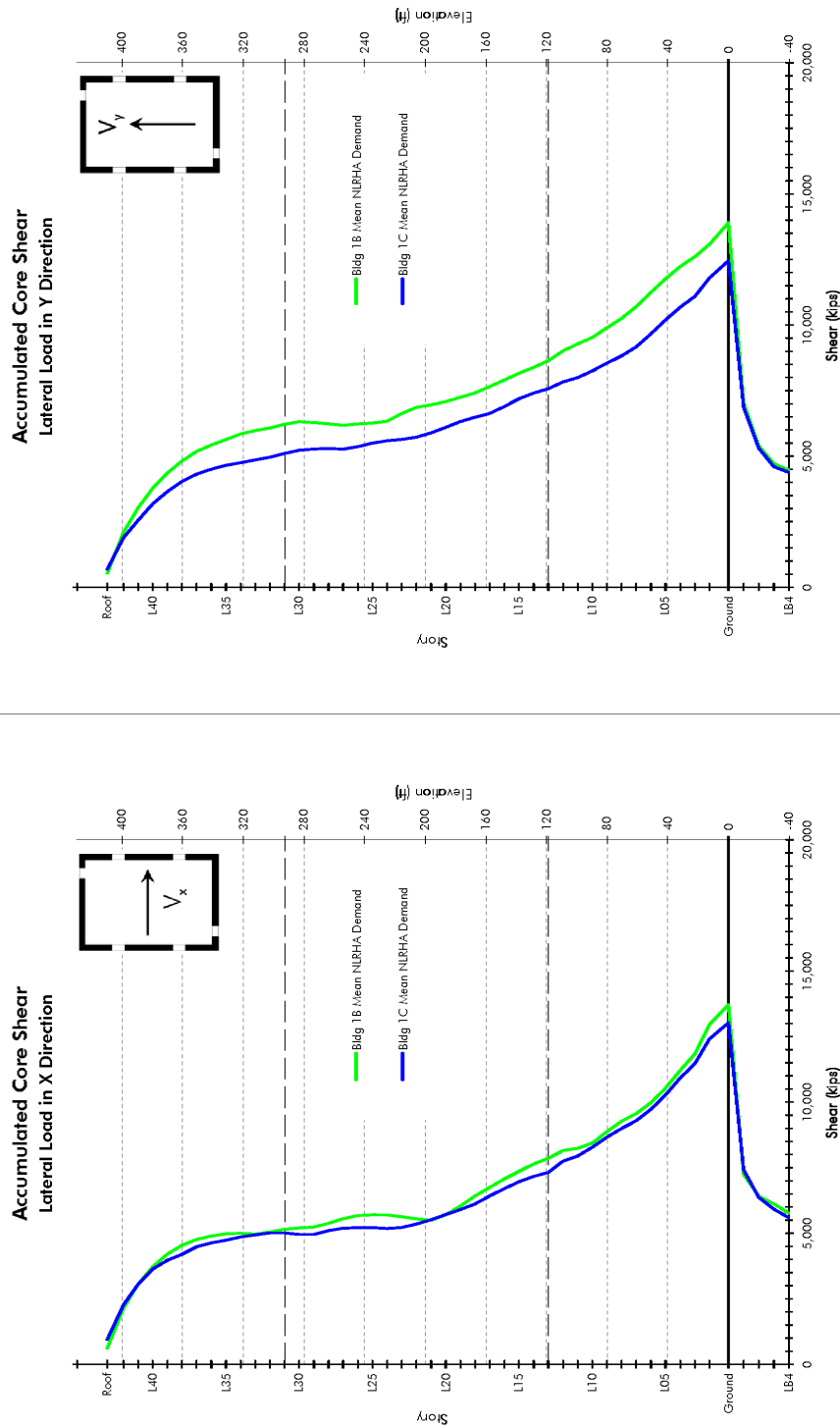

Figure 21. MCE Core Wall Shear Force Comparison

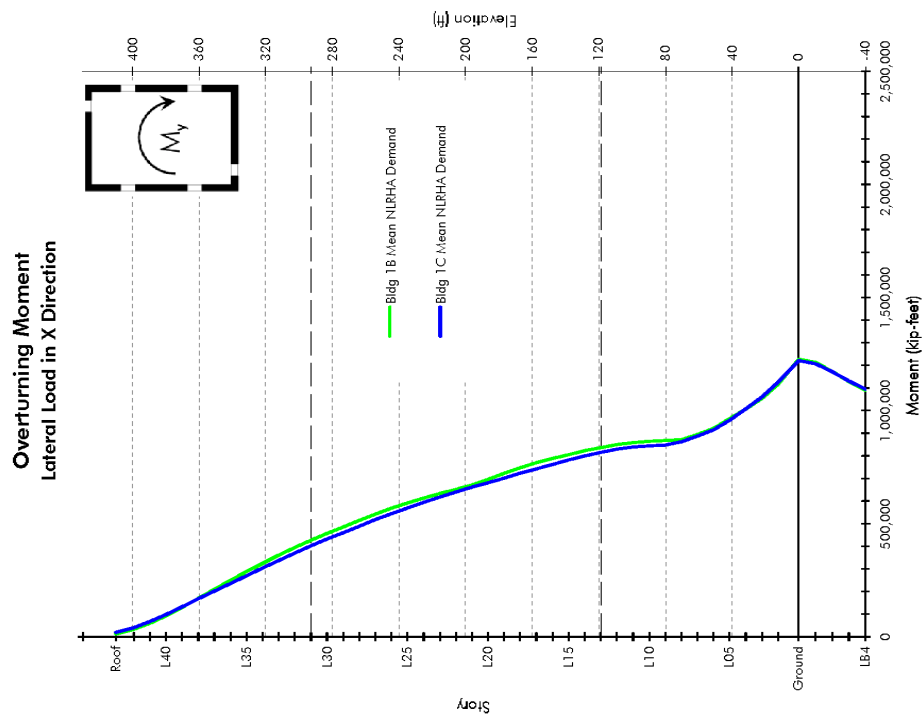
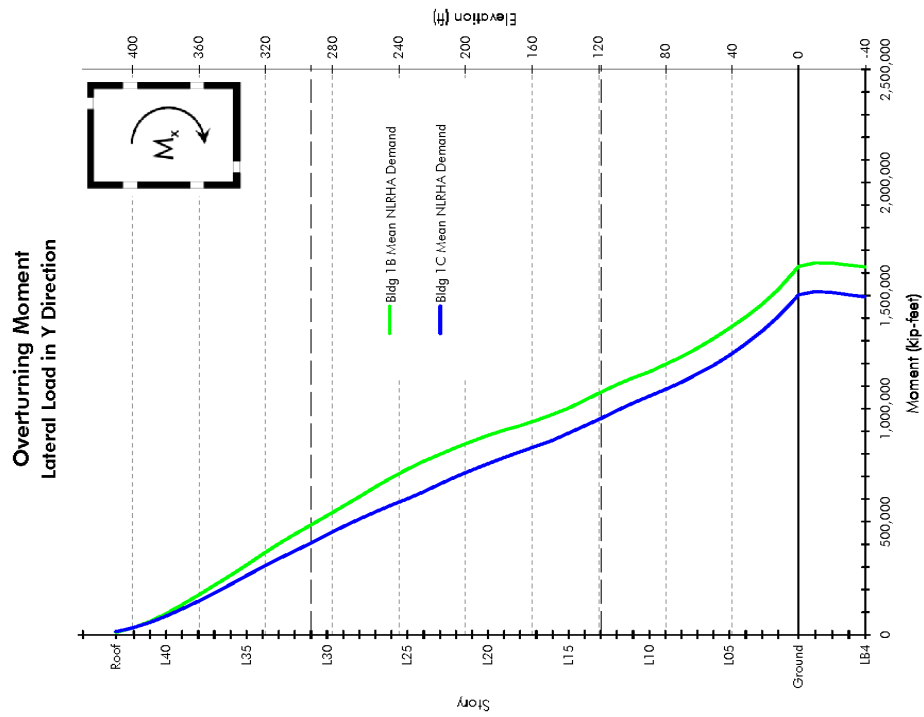

Figure 22. MCE Core Wall Overturning Moment Comparison

Figure 23 compares the calculated MCE drifts for Buildings 1B and 1C.

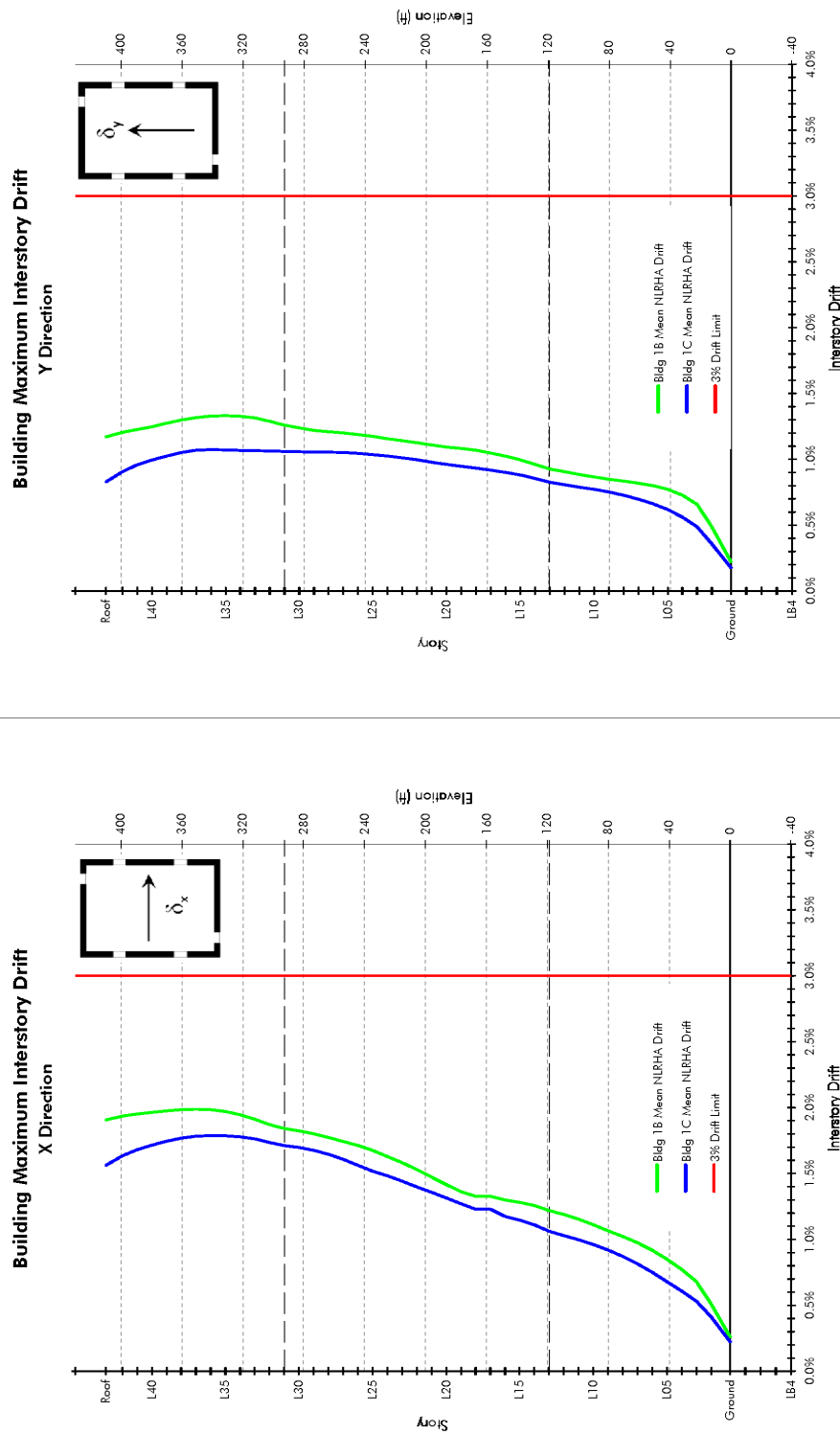

Figure 23. MCE Story Drift Comparison

Figures 24 to 26 compare the MCE coupling beam rotations for Buildings 1B and 1C.

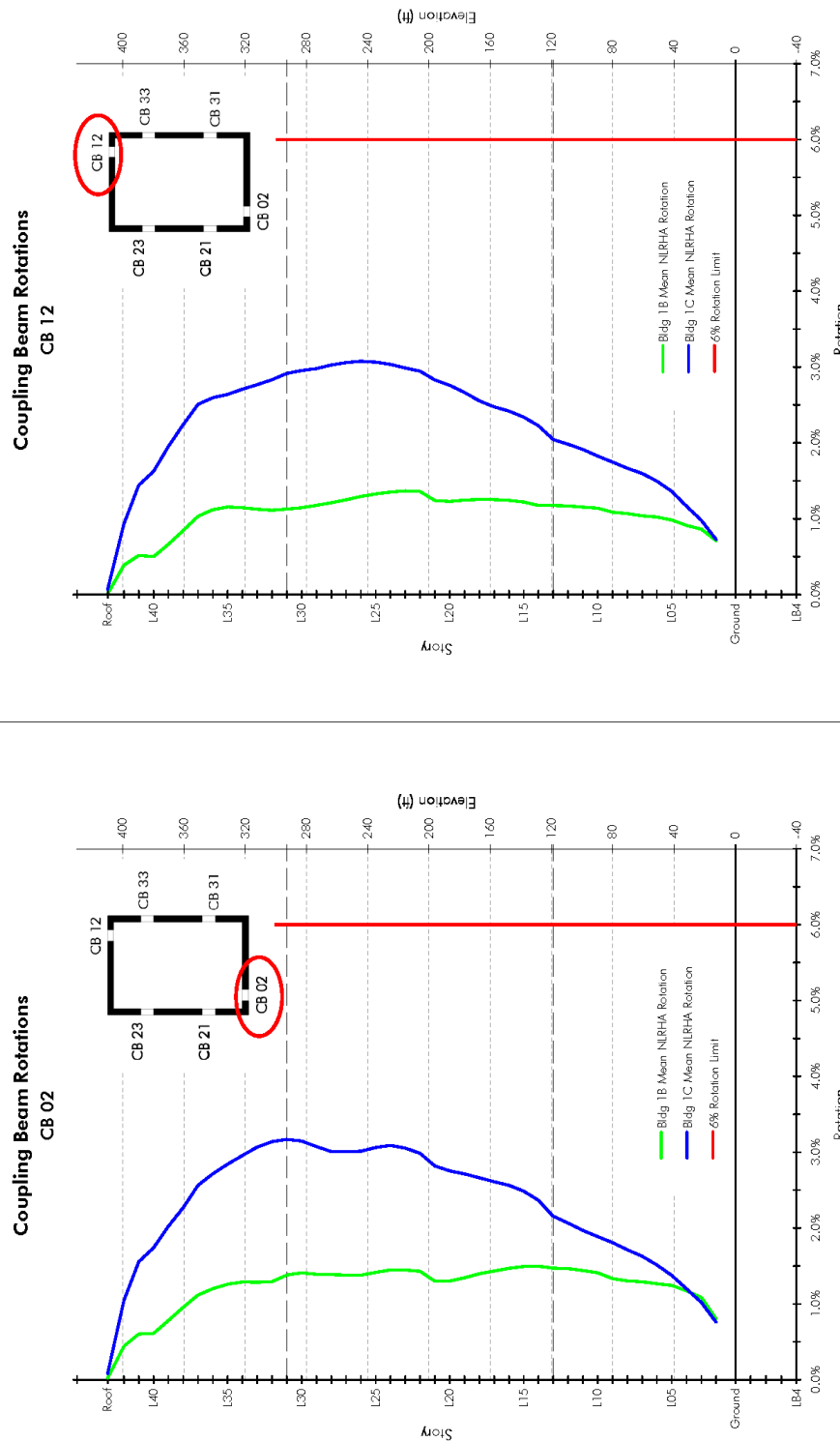

Figure 24. MCE Coupling Beam Rotation Comparison

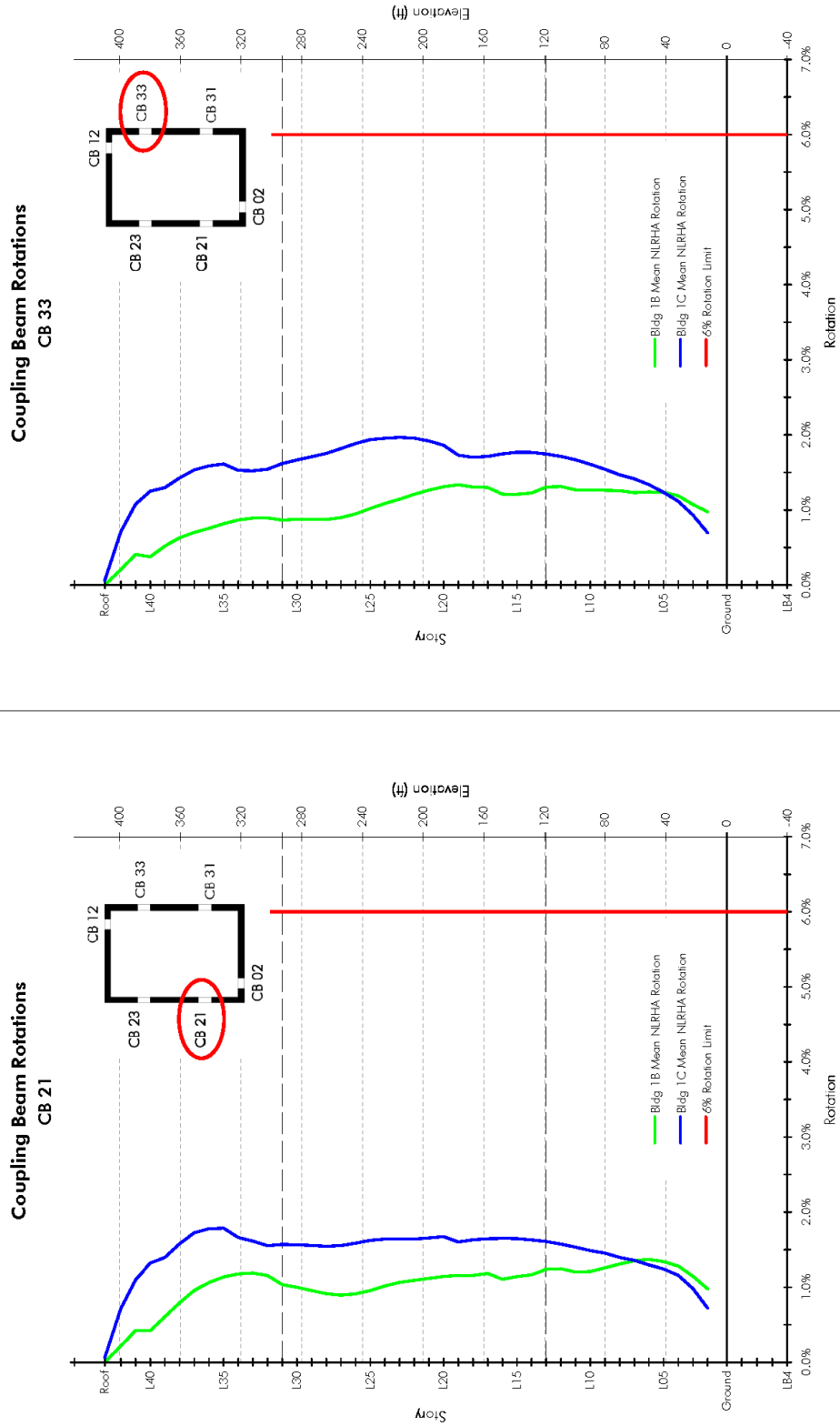

Figure 25. MCE Coupling Beam Rotation Comparison

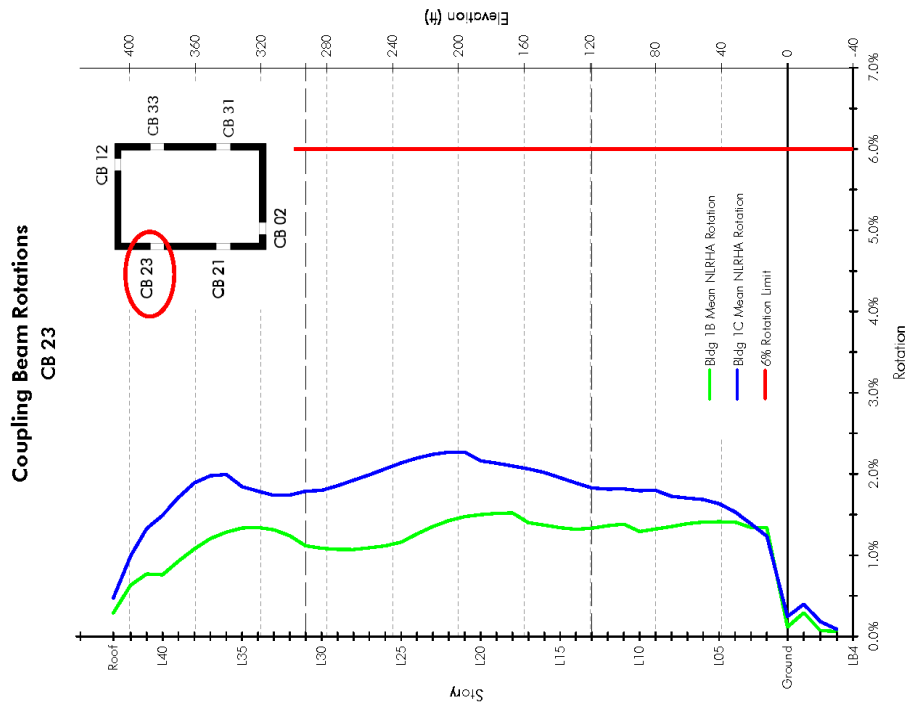
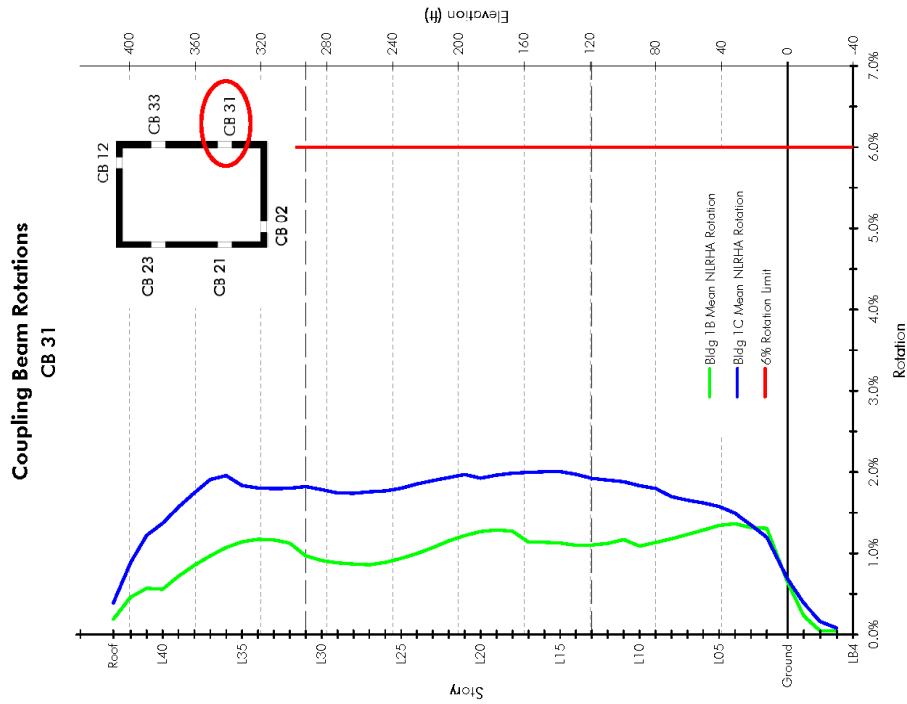

Figure 26. MCE Coupling Beam Rotation Comparison

The appendices to this report contain more detailed information related to the design and verification analyses performed on the three buildings.

Appendix	Title	Buildings
1	Rebar Design Drawings	1A, 1B, and 1C
2	Coupling Beam Design Charts	1A, 1B, and 1C
3	Drift Plots – MCE Level	1B and 1C
4	Shear and Overturning Plots – MCE Level	1B and 1C
5	Coupling Beam Rotations – MCE Level	1B and 1C
6	Compression and Tension Strains – MCE Level	1B and 1C
7	Wall Panel Shear – MCE Level	1B and 1C

OBSERVATIONS AND CONCLUSIONS

The following observations are made regarding the comparison of the three designs.

- Core wall shear is the prevailing design parameter and governs the determination of wall thickness for all of the designs. The thickest walls were required for Building 1C, and the thinnest walls were required for Building 1A.
- While MCE-level checks were not performed on Building 1A, wall shear demands are expected to be well above the provided capacity and may lead to an increased likelihood of collapse when compared to Buildings 1B and 1C. The provided shear reinforcing only meets the demands required by the building code without consideration of the flexural strength of the core walls.
- Serviceability-level demands for Building 1C were approximately 40 percent greater than those for Building 1B due to the increase in seismic hazard (43-year MRI versus 25-year MRI). Wind demands were not a controlling parameter in any of the designs.
- Coupling beam reinforcement is smallest for Building 1C even though it has the largest calculated coupling beam demands under the serviceability analysis. The reinforcement selected for the coupling beams for Buildings 1A and 1B is approximately the same.
- The provided vertical wall reinforcement is greatest for Building 1C and smallest for Building 1A. This would indicate that Building 1C exhibits greater strong pier/weak coupling beam behavior than do the other two designs.

Regarding the performance of Buildings 1B and 1C under MCE-level demands, the following observations are made:

- The average inter-story drifts fall below the acceptance criteria of 3 percent for both buildings. Drift demands are slightly higher in Building 1B.
- Coupling beam rotation demands are between 1 and 3 percent for Building 1C. Building 1B has slightly lower demands of between 1 and 2 percent. For both buildings, coupling beam rotation demands fall well below the acceptance criteria.
- A preliminary assumption for areas of confined and unconfined concrete was needed in order to build the non-linear model. The compression strain plots indicate that the concrete material used in the core wall models remains elastic in compression for the full height of the tower. As a result, it should be possible to reduce the amount of confinement initially assumed in the non-linear model. This refinement was not employed for this case study.
- At every level, the tensile strain demands meet the acceptance criteria. Small amounts of distributed yielding are observed over nearly the full height of both buildings, with the largest tensile strains occurring at the base of the core walls.
- The revised earthquake records when applied to Building 1B lead to some of the wall panels being slightly overstressed in shear. If this design were further developed, additional shear reinforcing would need to be provided to address these localized areas of overstress. Based on the data from the shear plot of Wall Pier 11, the thickness of the short walls of the core may also need to be increased to limit shear stress to $10\sqrt{f_c}$.
- Most of the wall panels for Building 1B were designed for roughly 3 to 3.5 times the shear force calculated under the service-level analysis. The ratio for Building 1C is slightly lower, as design values are two to three times the shear force calculated under the service-level analysis.
- The wall thickness selected for Building 1C appears to be somewhat thicker than optimal. MCE-level wall pier shear demands fall below the code limit on shear stress, particularly in the lower floors of the core. If this building were going to be constructed, MKA would likely iterate a few times on the wall thickness to determine the optimal balance of concrete volume and rebar density.

APPENDIX 1
REBAR DESIGN DRAWINGS
(BUILDINGS 1A, 1B, AND 1C)



MAGNUSSON
KLEMENCIC
ASSOCIATES



BUILDING 1A - VERTICAL REINFORCING

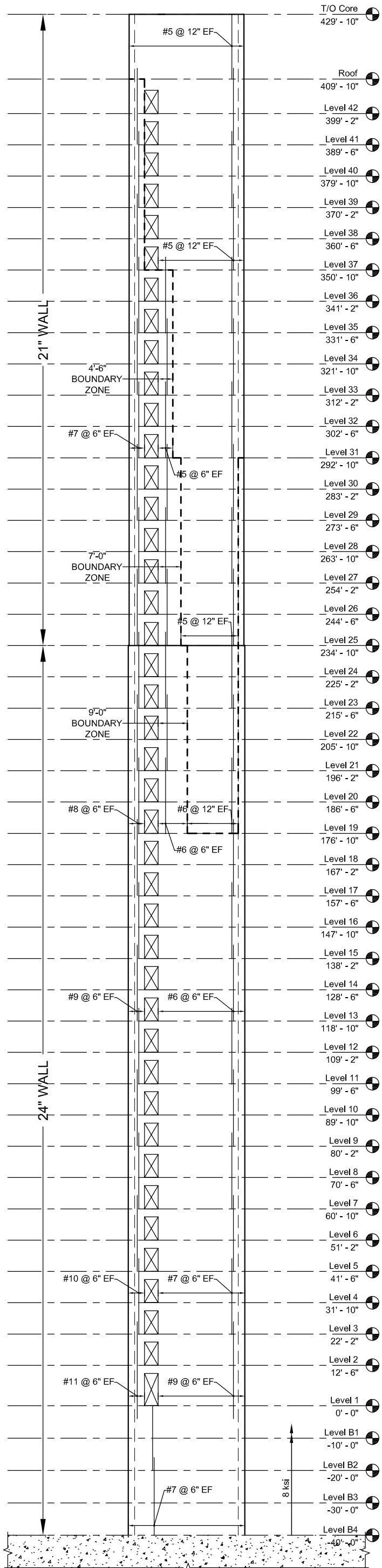

A NORTH & SOUTH ELEVATION

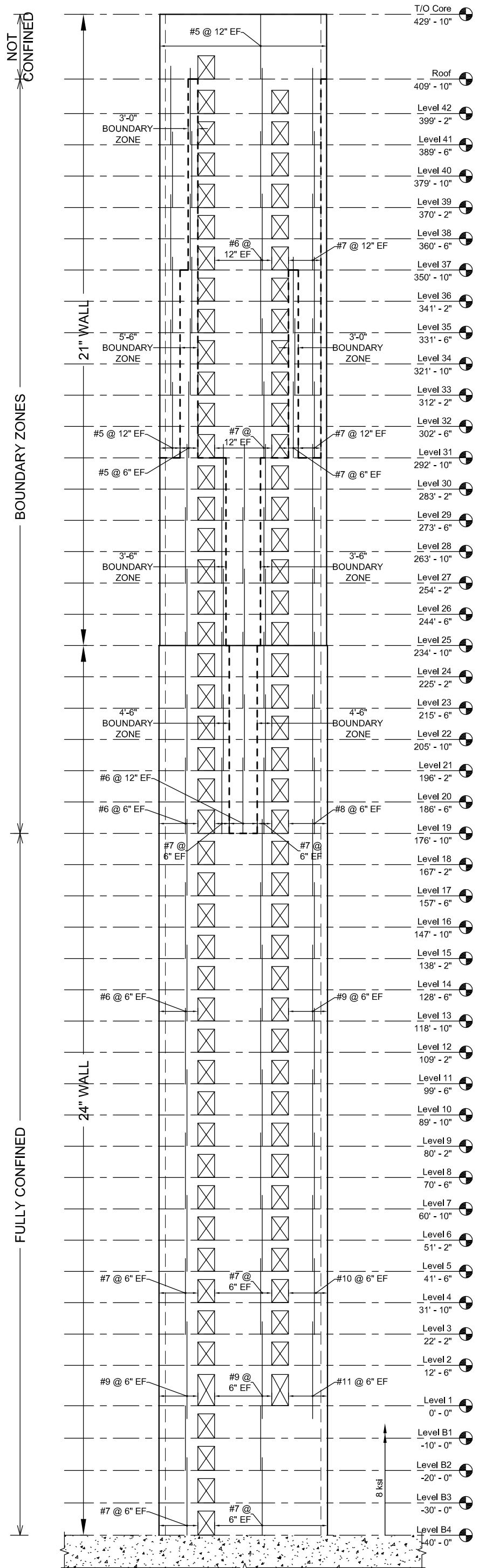

B EAST & WEST ELEVATION

BUILDING 1A - HORIZONTAL & COUPLING BEAM REINFORCING

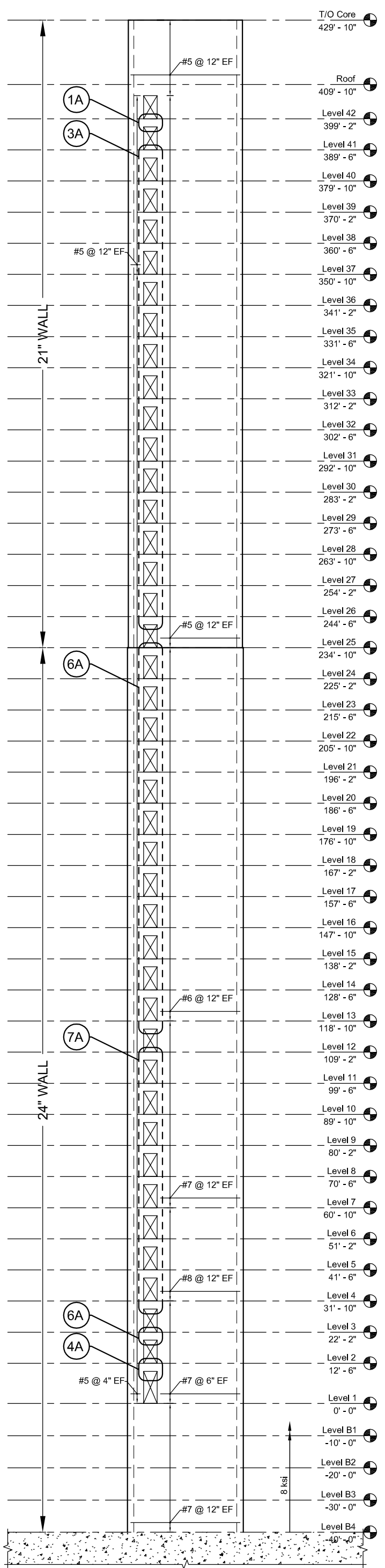

A NORTH & SOUTH ELEVATION

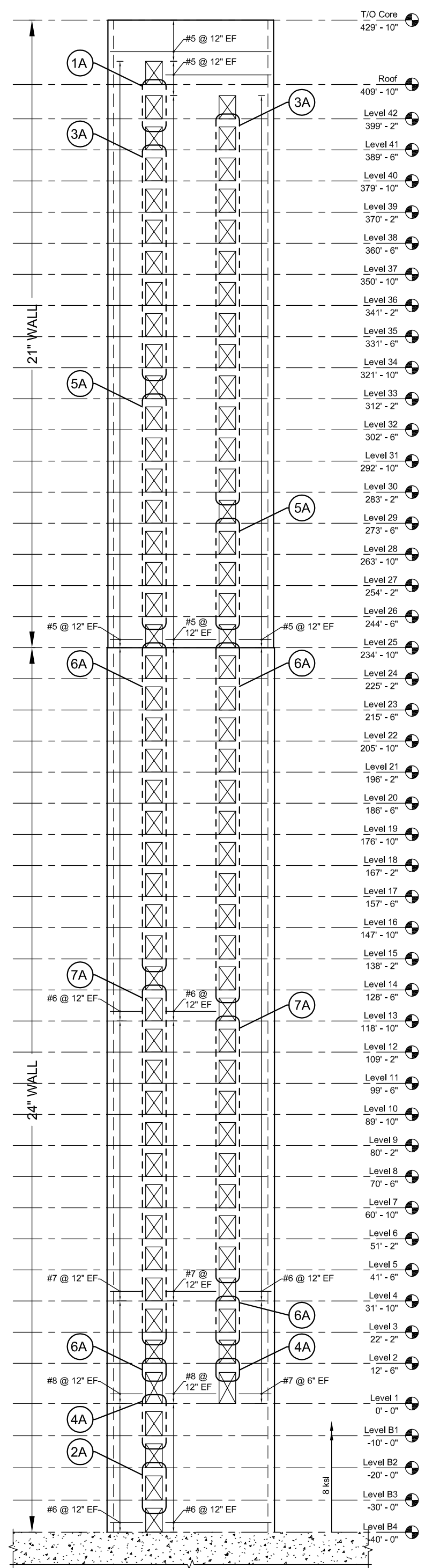

B EAST & WEST ELEVATION

BUILDING 1A

NOTES:

- IF EMBED LENGTH OF BAR "a" CANNOT BE ACHIEVED DUE TO EDGE OF CORE WALL, PROVIDE "L_{TERM}" LENGTH BEYOND EDGE OF OPENING AND USE A LENTON TERMINATOR AT END OF REINFORCING.

FOR F_y = 60KSI, "L_{TERM}" IS AS FOLLOWS:

SIZE	"L _{TERM} "
#5	14"
#6	17"
#7	20"
#8	22"
#9	24"
#10	27"
#11	30"

- FOR F_y = 75 KSI, MULTIPLY L_{TERM} VALUES BY 1.25.
- "EMBED" = LENGTH FROM "EMBED TABLE 1" OR "EMBED TABLE 2" DEPENDING ON WHETHER OR NOT THE HOOPS AND CROSS TIES FULLY ENCLOSE THE REBAR EMBED LENGTH IN THE WALL.

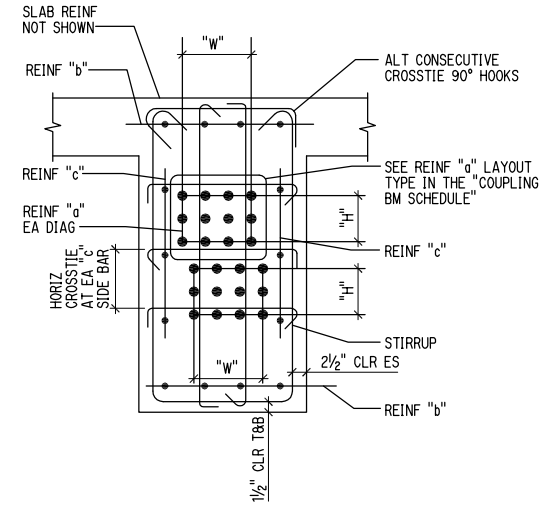
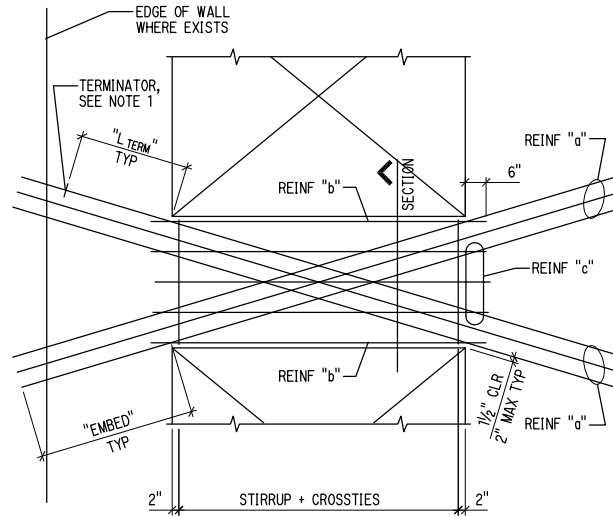

TYPICAL COUPLING BEAM

TYPICAL COUPLING BEAM SECTION

NOTES:

- DEPTH OF COUPLING BEAMS PER "SHEAR WALL ELEVATIONS". COUPLING BEAM WIDTH MATCHES ADJACENT SHEAR WALLS.
- CONCRETE STRENGTH OF ALL COUPLING BEAMS SHALL MATCH THAT OF THE ADJACENT WALLS.
- ALTERNATE CROSSTIES END FOR END.
- REINFORCING "a", "b", & "c" SHALL BE SPECIAL DUCTILE QUALITY. SEE "GENERAL NOTES" FOR CRITERIA. ALL BARS ARE GRADE 60 UNLESS NOTED OTHERWISE.
- REFER TO "COUPLING BEAM DETAILS FOR DESCRIPTIONS OF "W" AND "H" DIMENSIONS. THESE DIMENSIONS REFER TO THE PERIMETER BAR CENTER LINES FOR EACH REINFORCING "a" LAYOUT TYPE. THE "W" DIMENSION IS A MINIMUM. THE "H" DIMENSION IS A MAXIMUM.
- TYPE "c" REINFORCEMENT IS BASED ON DEPTH:
 30" = (4) #5
 34" = (5) #5
 42" = (6) #5

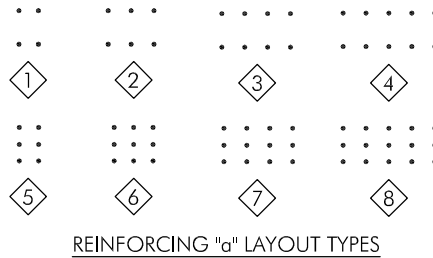

REINFORCING "a" LAYOUT TYPES

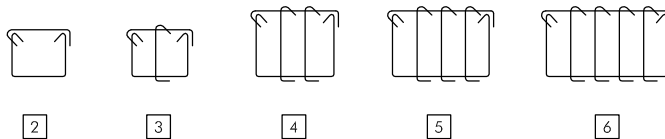

STIRRUP TYPES

COUPLING BEAM SCHEDULE

MARK	DIMENSIONS (INCHES)		REINFORCING a		REINFORCING b		STIRRUP			REINFORCING "a" LAYOUT	REMARKS
	W	H	#	SIZE	#	SIZE	SIZE	TYPE	SPCG	TYPE	
1A	6	4	4	#8	3	#5	#5	3	4"	1	
2A	6	4	4	#8	4	#5	#5	4	4"	1	
3A	8	4	6	#10	3	#5	#5	3	4"	2	
4A	8	4	6	#10	4	#5	#5	4	4"	2	
5A	10	8	9	#10	3	#5	#5	3	4"	6	
6A	10	8	9	#10	4	#5	#5	4	4"	6	
7A	12	8	9	#11	4	#5	#5	4	4"	6	

COUPLING BEAM SCHEDULE

BUILDING 1B - VERTICAL REINFORCING

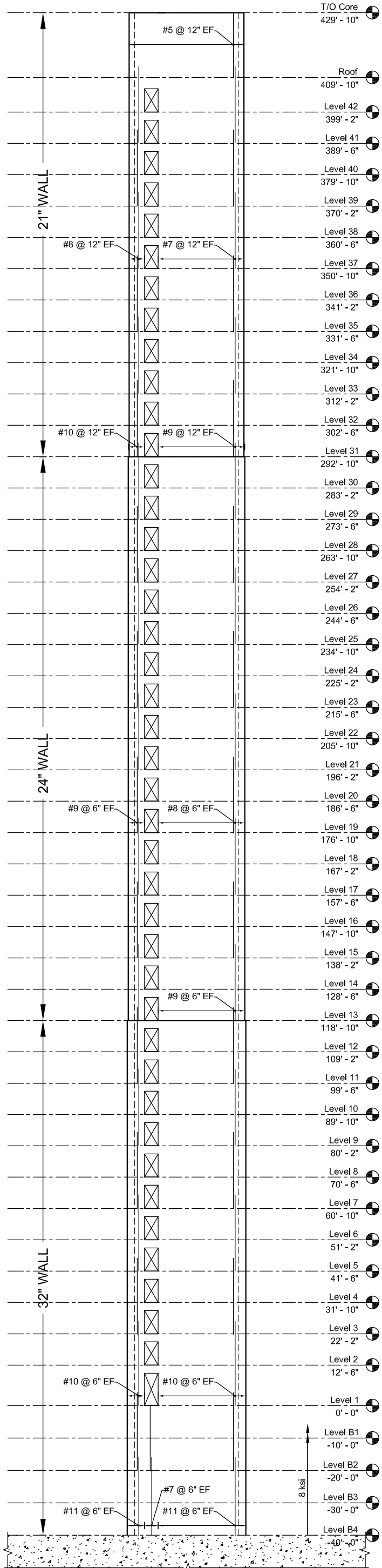

A

NORTH & SOUTH ELEVATION

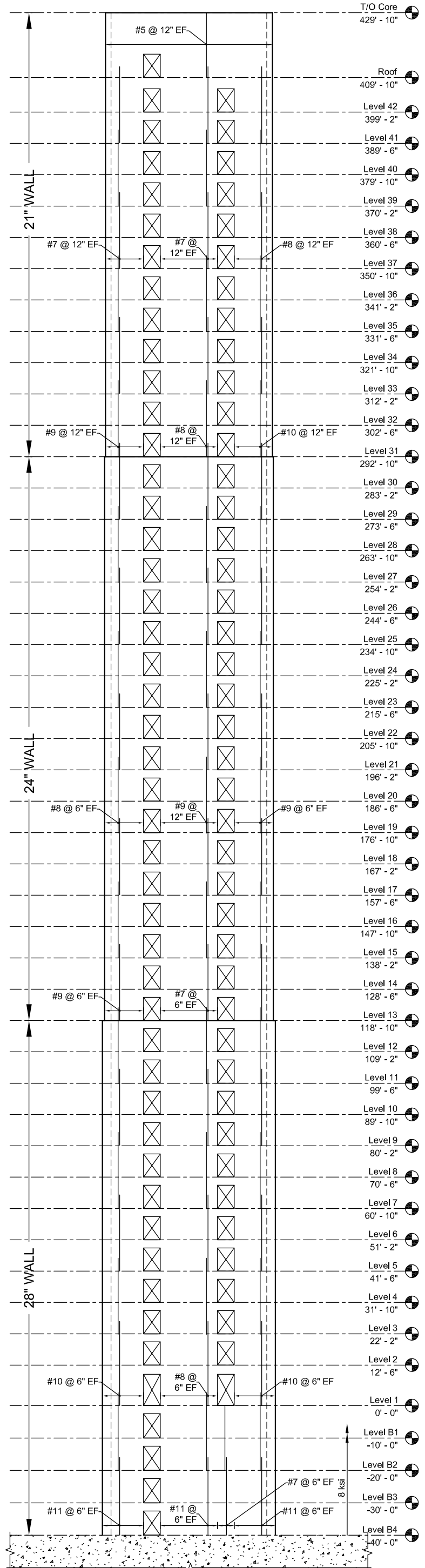

B

EAST & WEST ELEVATION

BUILDING 1B - HORIZONTAL & COUPLING BEAM REINFORCING

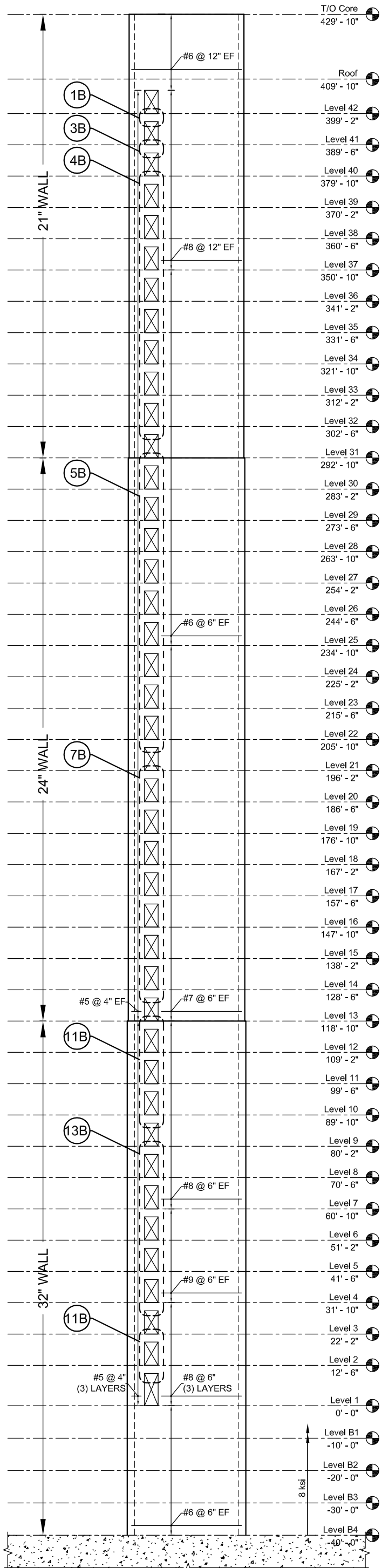

A NORTH & SOUTH ELEVATION

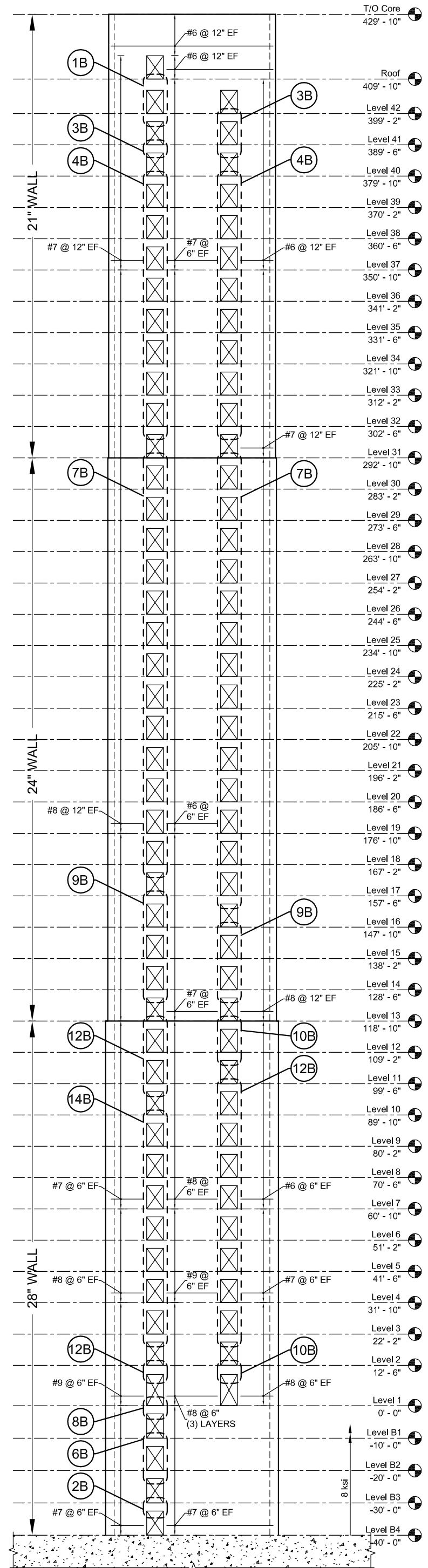

B EAST & WEST ELEVATION

BUILDING 1B

NOTES:

- IF EMBED LENGTH OF BAR "a" CANNOT BE ACHIEVED DUE TO EDGE OF CORE WALL, PROVIDE "L_{TERM}" LENGTH BEYOND EDGE OF OPENING AND USE A LENTON TERMINATOR AT END OF REINFORCING.

FOR F_y = 60KSI, "L_{TERM}" IS AS FOLLOWS:

SIZE	"L _{TERM} "
#5	14"
#6	17"
#7	20"
#8	22"
#9	24"
#10	27"
#11	30"

- FOR F_y = 75 KSI, MULTIPLY L_{TERM} VALUES BY 1.25.
- "EMBED" = LENGTH FROM "EMBED TABLE 1" OR "EMBED TABLE 2" DEPENDING ON WHETHER OR NOT THE HOOPS AND CROSS TIES FULLY ENCLOSE THE REBAR EMBED LENGTH IN THE WALL.

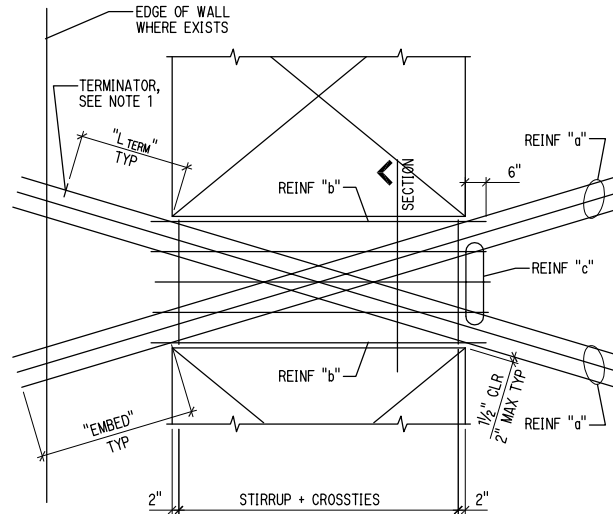

TYPICAL COUPLING BEAM

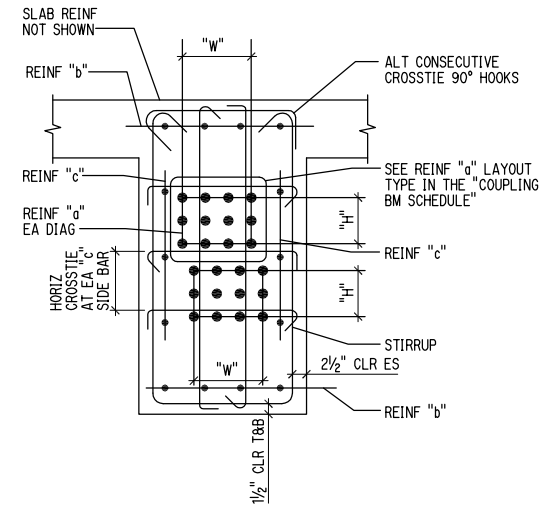

TYPICAL COUPLING BEAM SECTION

NOTES:

- DEPTH OF COUPLING BEAMS PER "SHEAR WALL ELEVATIONS". COUPLING BEAM WIDTH MATCHES ADJACENT SHEAR WALLS.
- CONCRETE STRENGTH OF ALL COUPLING BEAMS SHALL MATCH THAT OF THE ADJACENT WALLS.
- ALTERNATE CROSSTIES END FOR END.
- REINFORCING "a", "b", & "c" SHALL BE SPECIAL DUCTILE QUALITY. SEE "GENERAL NOTES" FOR CRITERIA. ALL BARS ARE GRADE 60 UNLESS NOTED OTHERWISE.
- REFER TO "COUPLING BEAM DETAILS FOR DESCRIPTIONS OF "W" AND "H" DIMENSIONS. THESE DIMENSIONS REFER TO THE PERIMETER BAR CENTER LINES FOR EACH REINFORCING "a" LAYOUT TYPE. THE "W" DIMENSION IS A MINIMUM. THE "H" DIMENSION IS A MAXIMUM.
- TYPE "c" REINFORCEMENT IS BASED ON DEPTH:
30" = (4) #5
34" = (5) #5
42" = (6) #5

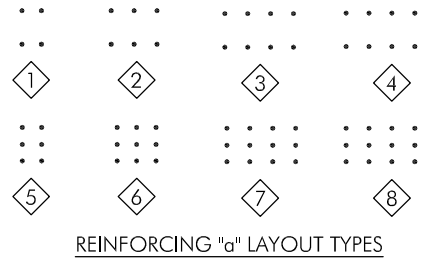

REINFORCING "a" LAYOUT TYPES

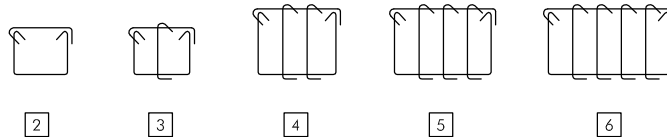

STIRRUP TYPES

COUPLING BEAM SCHEDULE

MARK	DIMENSIONS (INCHES)		REINFORCING a		REINFORCING b		STIRRUP			REINFORCING "a" LAYOUT	REMARKS
	W	H	#	SIZE	#	SIZE	SIZE	TYPE	SPCG	TYPE	
1B	6	4	4	#8	3	#5	#5	3	4"	1	
2B	6	4	4	#8	4	#5	#5	4	4"	1	
3B	6	4	6	#8	3	#5	#5	3	4"	2	
4B	8	4	6	#10	3	#5	#5	3	4"	2	
5B	8	4	6	#10	4	#5	#5	4	5"	2	
6B	8	4	6	#10	4	#5	#5	4	4"	2	
7B	10	8	9	#10	4	#5	#5	4	5"	6	
8B	10	8	9	#10	4	#5	#5	4	4"	6	
9B	12	8	9	#11	4	#5	#5	4	5"	6	
10B	12	8	9	#11	4	#5	#5	4	4"	6	
11B	12	8	9	#11	5	#5	#5	5	5"	6	
12B	12	8	12	#10	4	#5	#5	4	4"	7	
13B	12	8	12	#10	5	#5	#5	5	5"	7	
14B	12	8	12	#11	4	#5	#5	4	4"	7	

COUPLING BEAM SCHEDULE

BUILDING 1C - VERTICAL REINFORCING

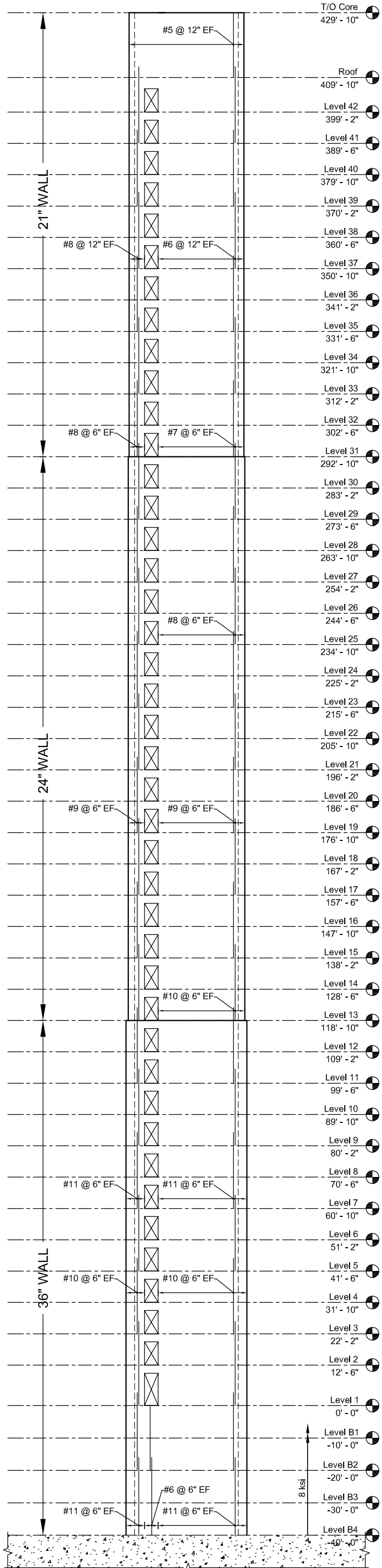

A

NORTH & SOUTH ELEVATION

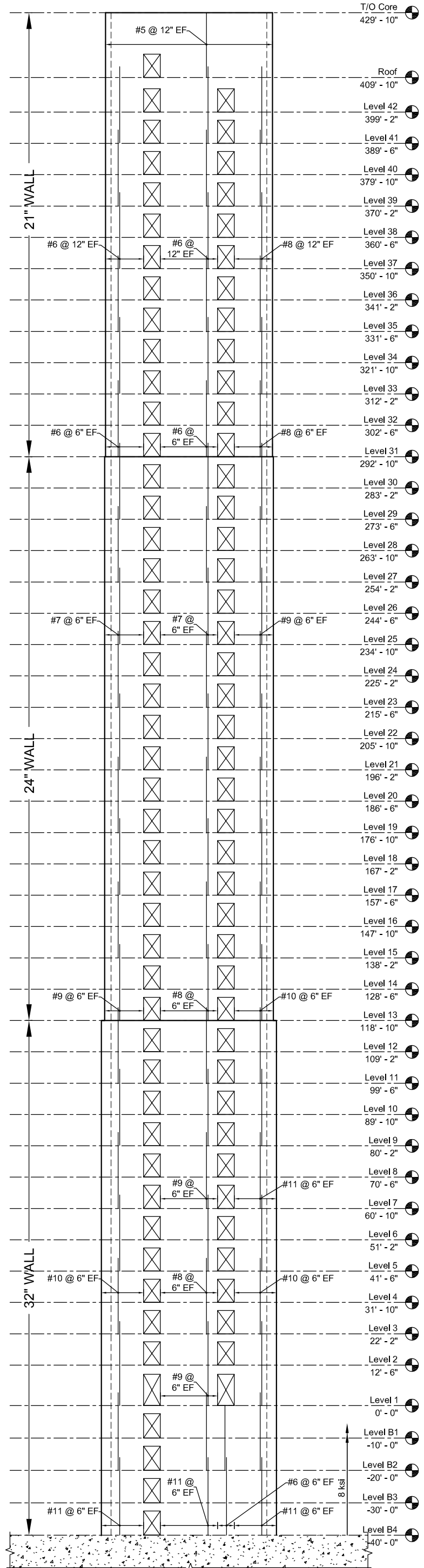

B

EAST & WEST ELEVATION

BUILDING 1C - HORIZONTAL & COUPLING BEAM REINFORCING

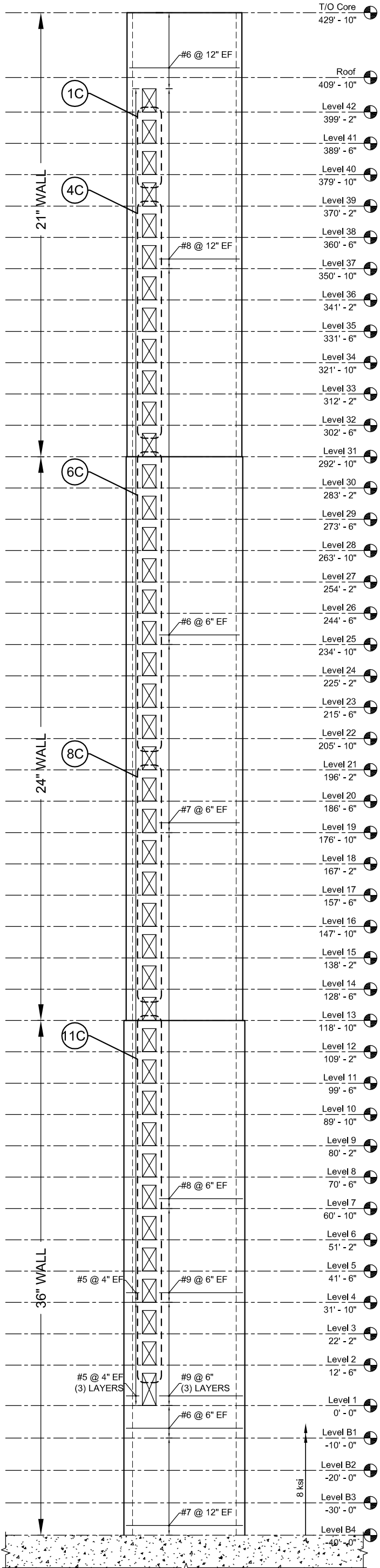

A

NORTH & SOUTH ELEVATION

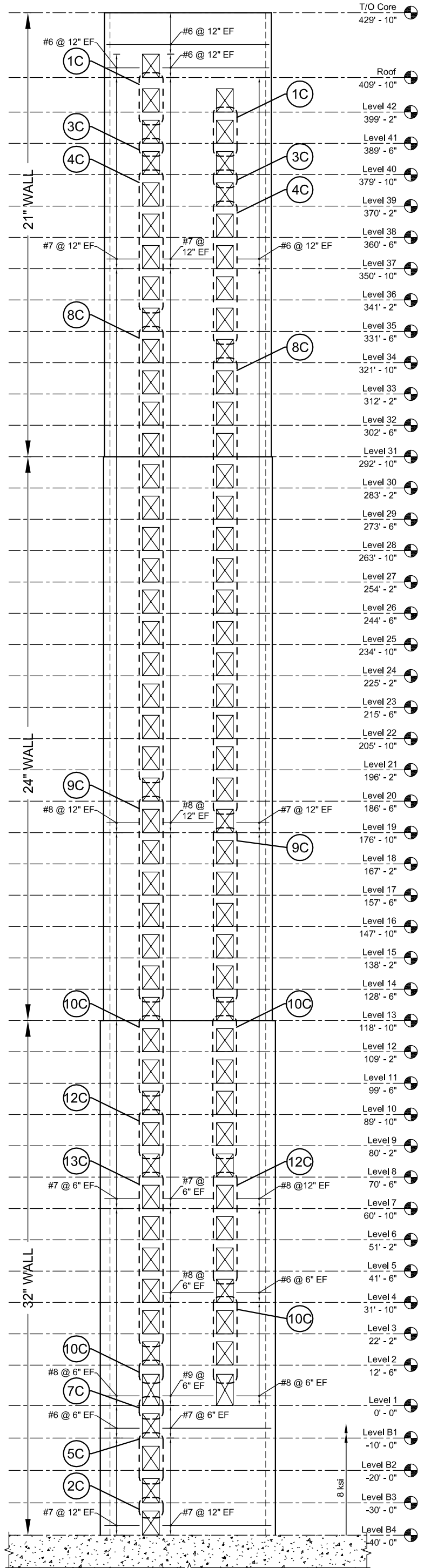

B

EAST & WEST ELEVATION

BUILDING 1C

NOTES:

- IF EMBED LENGTH OF BAR "a" CANNOT BE ACHIEVED DUE TO EDGE OF CORE WALL, PROVIDE "L_{TERM}" LENGTH BEYOND EDGE OF OPENING AND USE A LENTON TERMINATOR AT END OF REINFORCING.

FOR F_y = 60KSI, "L_{TERM}" IS AS FOLLOWS:

SIZE	"L _{TERM} "
#5	14"
#6	17"
#7	20"
#8	22"
#9	24"
#10	27"
#11	30"

- FOR F_y = 75 KSI, MULTIPLY L_{TERM} VALUES BY 1.25.
- "EMBED" = LENGTH FROM "EMBED TABLE 1" OR "EMBED TABLE 2" DEPENDING ON WHETHER OR NOT THE HOOPS AND CROSS TIES FULLY ENCLOSE THE REBAR EMBED LENGTH IN THE WALL.

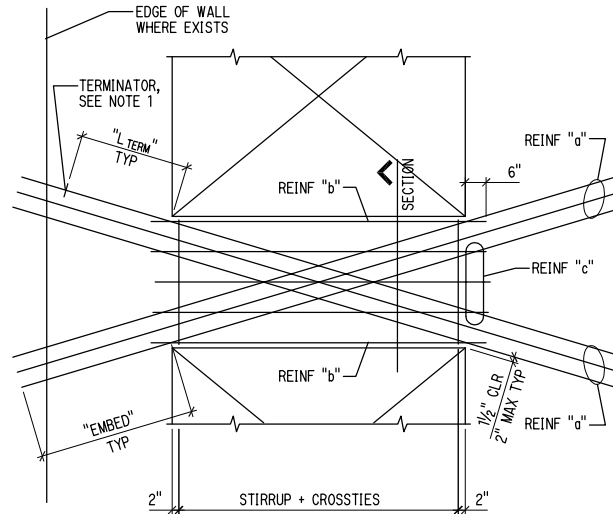

TYPICAL COUPLING BEAM

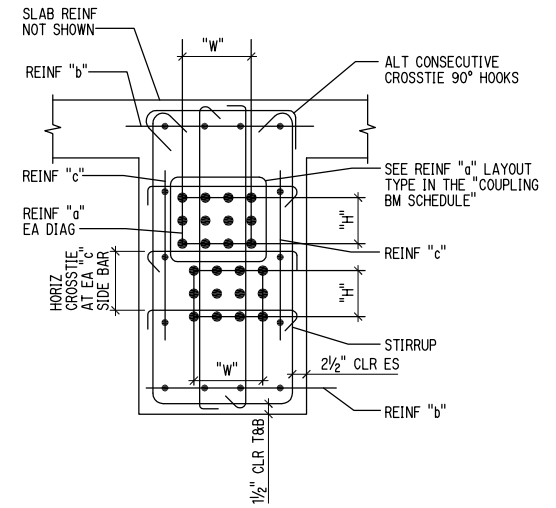

TYPICAL COUPLING BEAM SECTION

9

10

NOTES:

- DEPTH OF COUPLING BEAMS PER "SHEAR WALL ELEVATIONS". COUPLING BEAM WIDTH MATCHES ADJACENT SHEAR WALLS.
- CONCRETE STRENGTH OF ALL COUPLING BEAMS SHALL MATCH THAT OF THE ADJACENT WALLS.
- ALTERNATE CROSSTIES END FOR END.
- REINFORCING "a", "b", & "c" SHALL BE SPECIAL DUCTILE QUALITY. SEE "GENERAL NOTES" FOR CRITERIA. ALL BARS ARE GRADE 60 UNLESS NOTED OTHERWISE.
- REFER TO "COUPLING BEAM DETAILS FOR DESCRIPTIONS OF "W" AND "H" DIMENSIONS. THESE DIMENSIONS REFER TO THE PERIMETER BAR CENTER LINES FOR EACH REINFORCING "a" LAYOUT TYPE. THE "W" DIMENSION IS A MINIMUM. THE "H" DIMENSION IS A MAXIMUM.
- TYPE "c" REINFORCEMENT IS BASED ON DEPTH:
30" = (4) #5
34" = (4) #5
42" = (7) #5

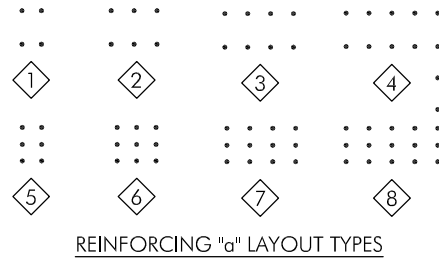

REINFORCING "a" LAYOUT TYPES

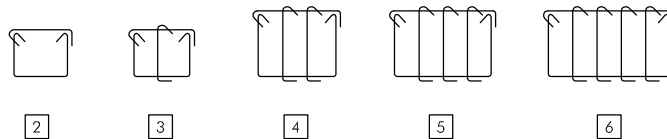

STIRRUP TYPES

COUPLING BEAM SCHEDULE

MARK	DIMENSIONS (INCHES)		REINFORCING a		REINFORCING b		STIRRUP			REINFORCING a LAYOUT	REMARKS
	W	H	#	SIZE	#	SIZE	SIZE	TYPE	SPCG	TYPE	
1C	6	4	4	#7	4	#5	#5	4	5"	1	
2C	6	4	4	#7	5	#5	#5	5	4"	1	
3C	6	4	4	#8	4	#5	#5	4	5"	1	
4C	6	4	6	#8	4	#5	#5	4	5"	2	
5C	6	4	6	#8	5	#5	#5	5	4"	2	
6C	4	8	6	#9	4	#5	#5	4	5"	5	
7C	8	4	6	#10	5	#5	#5	5	4"	2	
8C	4	8	6	#10	4	#5	#5	4	5"	5	
9C	4	8	6	#11	4	#5	#5	4	5"	5	
10C	10	8	9	#10	5	#5	#5	5	4"	6	
11C	10	8	9	#10	6	#5	#5	6	4"	6	
12C	10	8	12	#9	5	#5	#5	5	4"	7	
13C	12	8	9	#11	5	#5	#5	5	4"	6	

COUPLING BEAM SCHEDULE

15

APPENDIX 2
COUPLING BEAM DESIGN CHARTS
(BUILDINGS 1A, 1B, AND 1C)



MAGNUSSON
KLEMENCIC
ASSOCIATES



Building 1A

Coupling Beam Design Forces CB 02

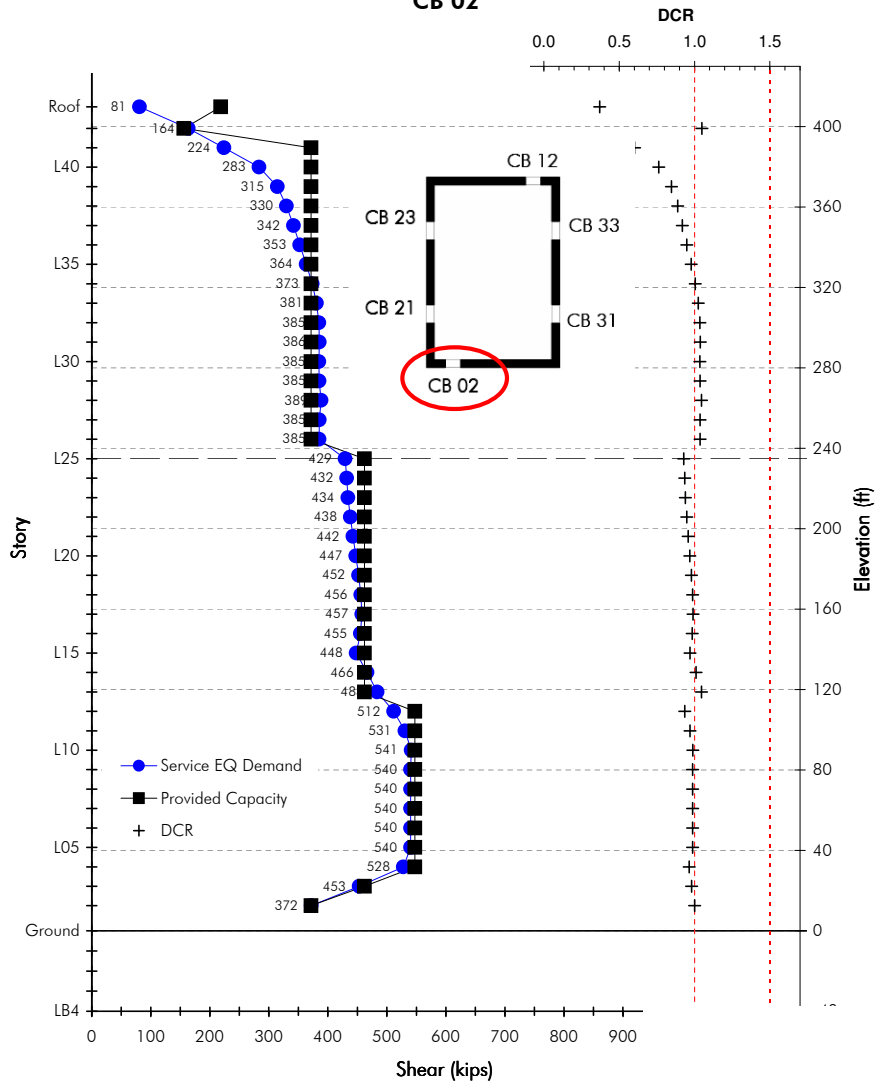

PEER TBI - Building 1A - Core Only Building for CSSC

Coupling Beam Design Forces CB 12

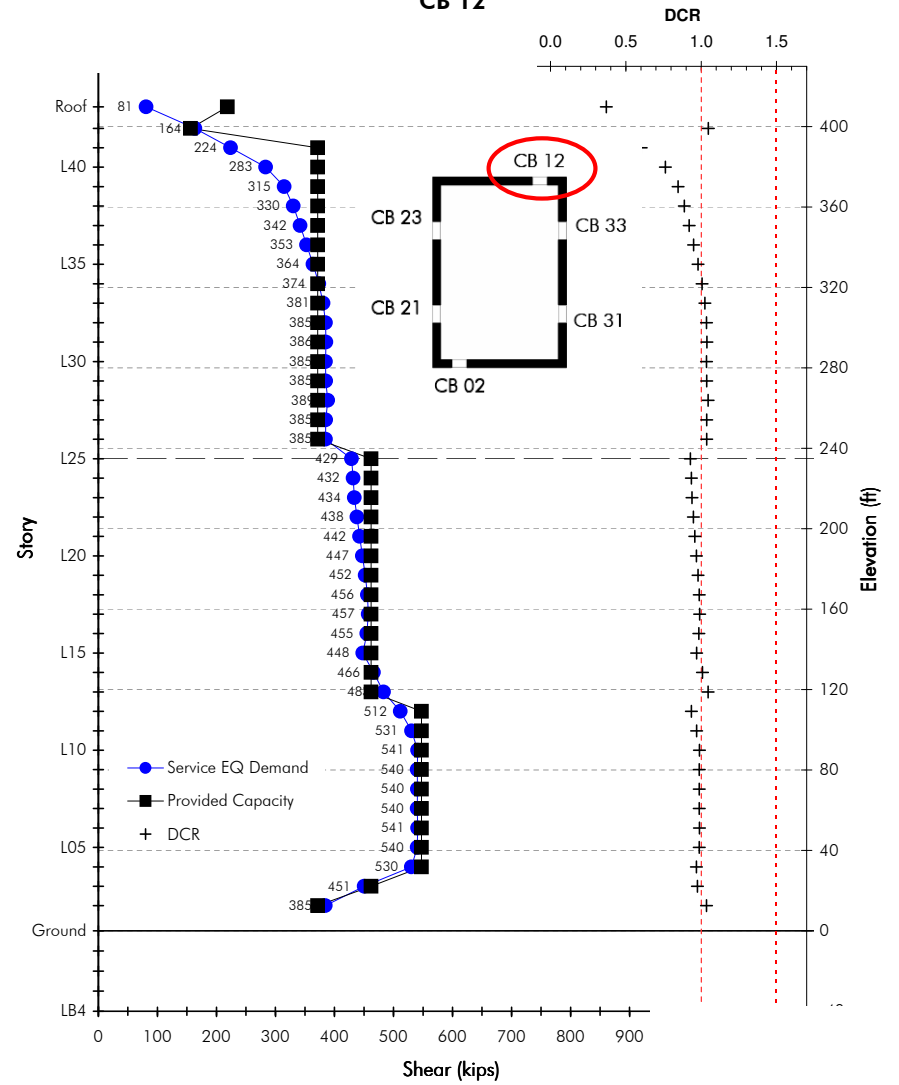

PEER TBI - Building 1A - Core Only Building for CSSC

Building 1A

Coupling Beam Design Forces CB 21

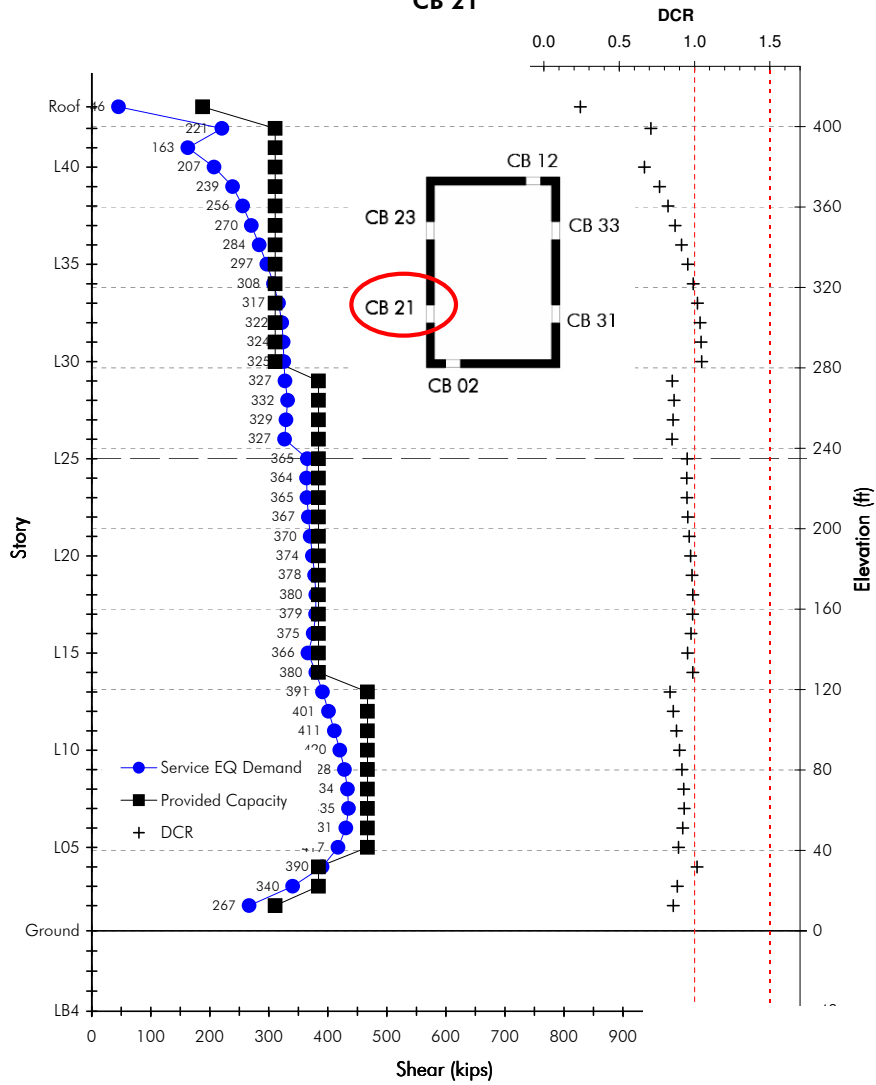

PEER TBI - Building 1A - Core Only Building for CSSC

Coupling Beam Design Forces CB 33

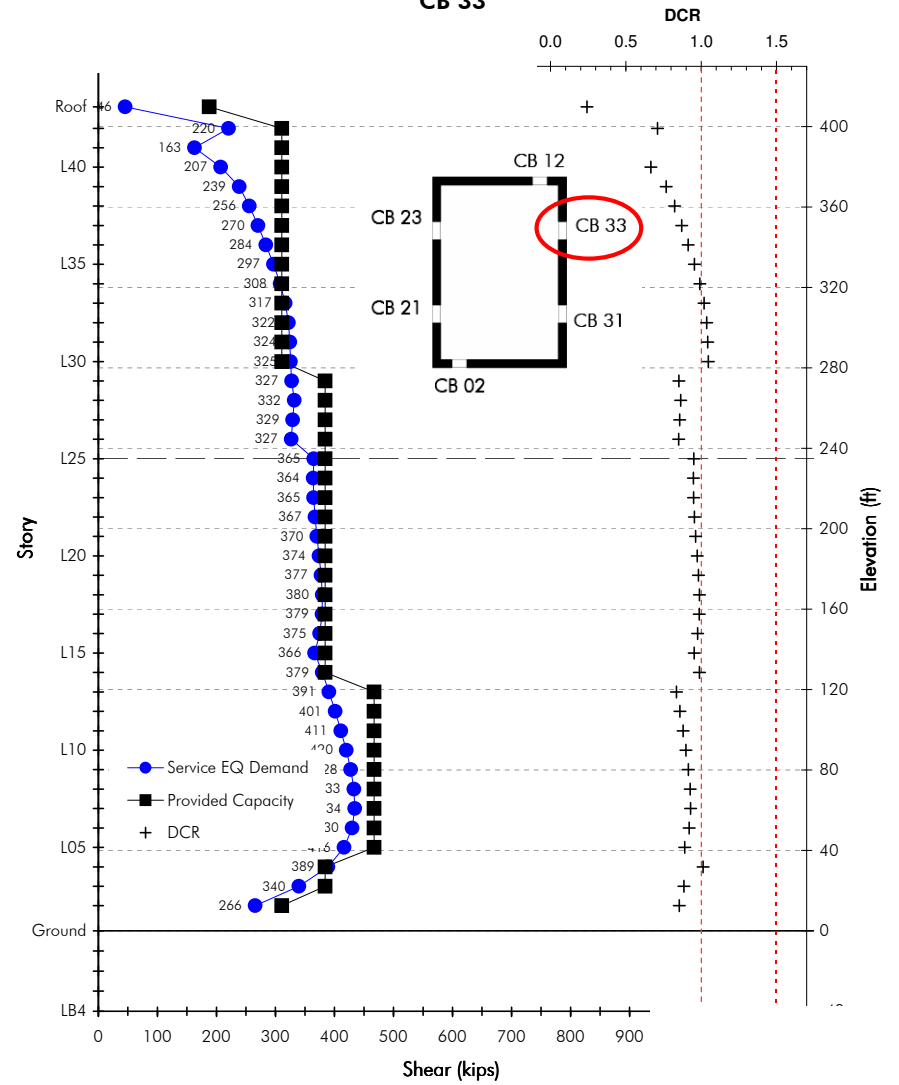

PEER TBI - Building 1A - Core Only Building for CSSC

Building 1A

Coupling Beam Design Forces CB 23

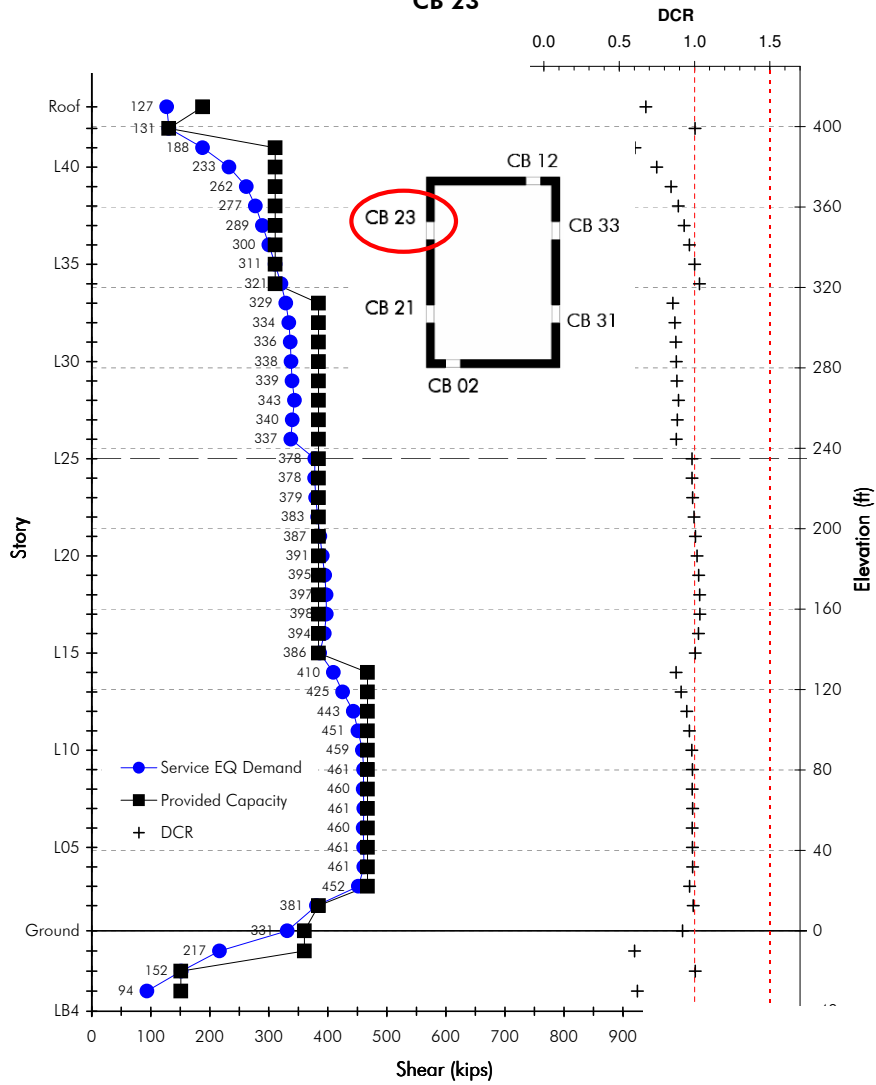

PEER TBI - Building 1A - Core Only Building for CSSC

Coupling Beam Design Forces CB 31

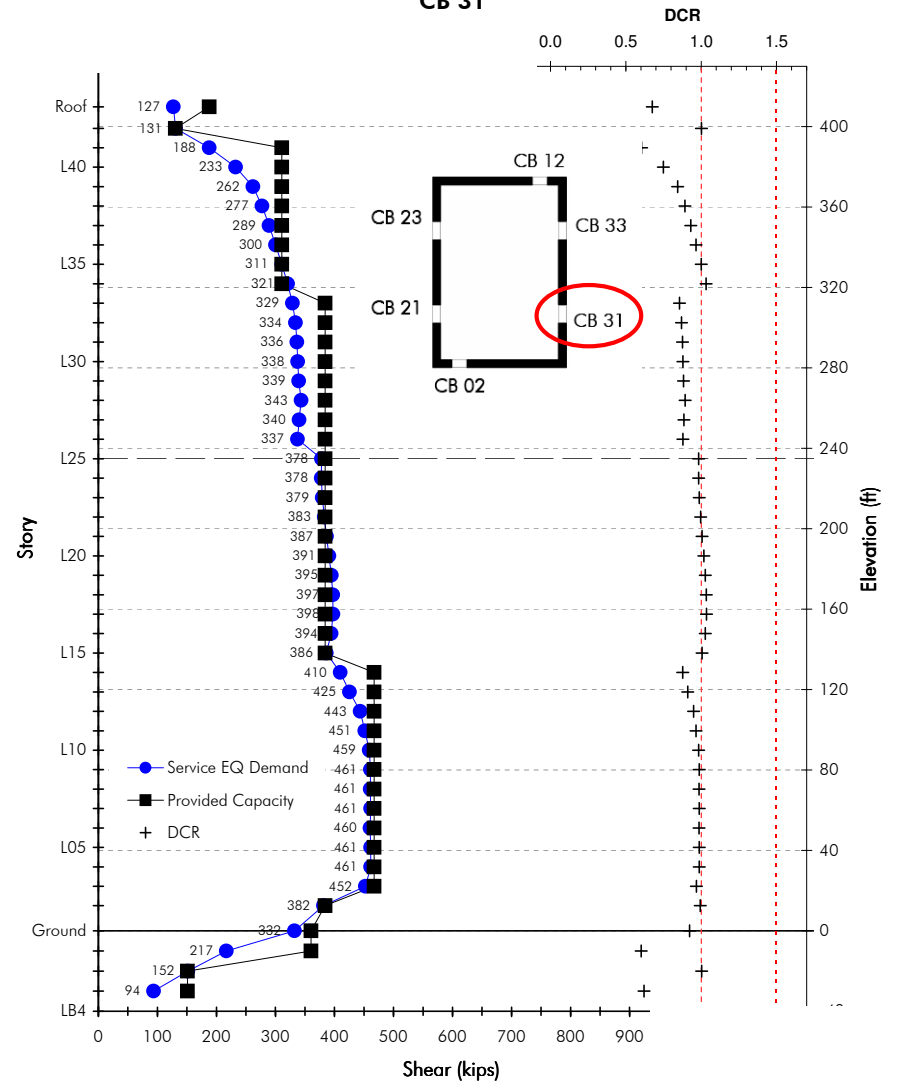

PEER TBI - Building 1A - Core Only Building for CSSC

Building 1B

Coupling Beam Design Forces CB 02

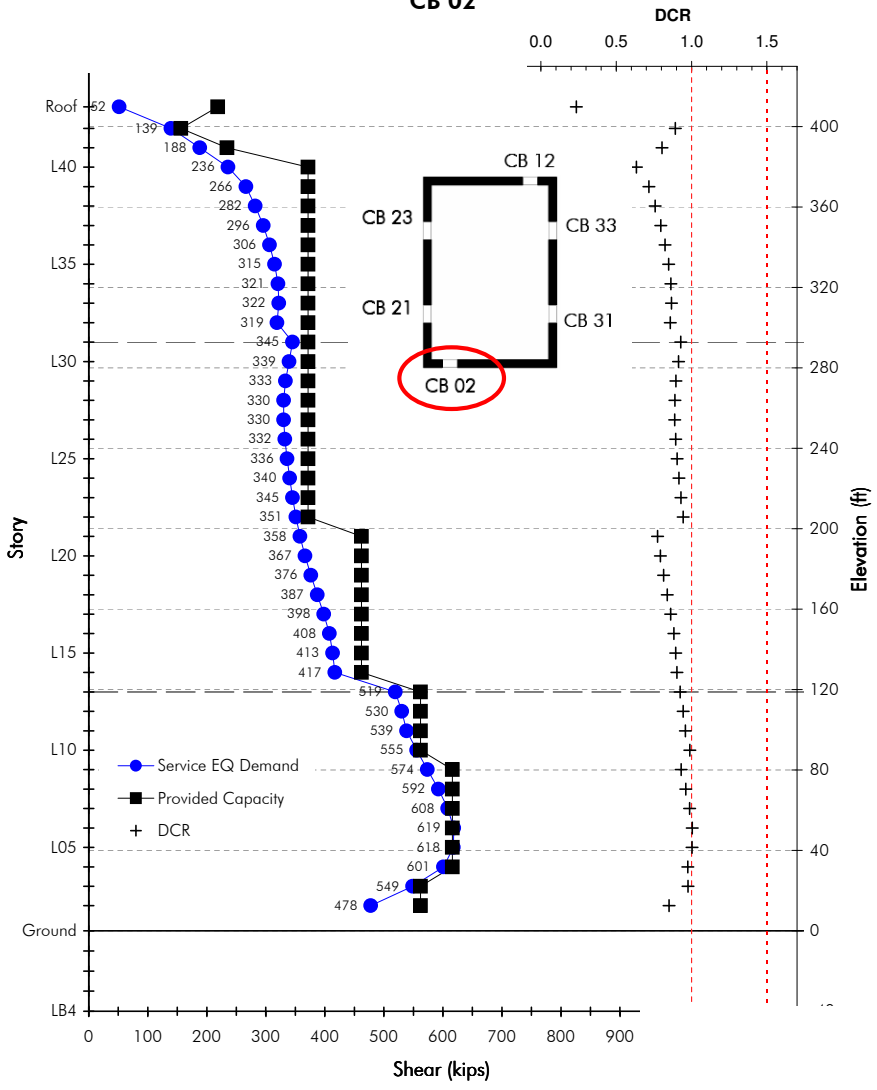

PEER TBI - Building 1B - Core Only Building for CSSC

Coupling Beam Design Forces CB 12

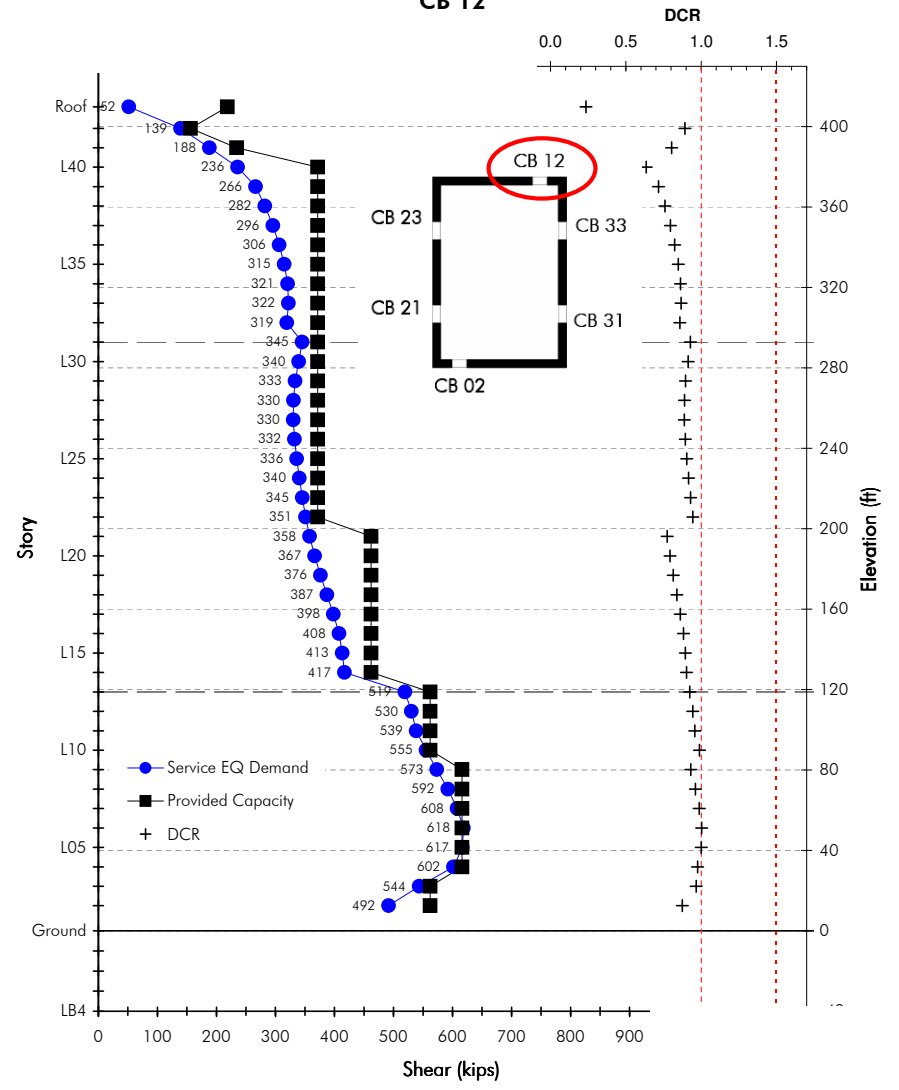

PEER TBI - Building 1B - Core Only Building for CSSC

Building 1B

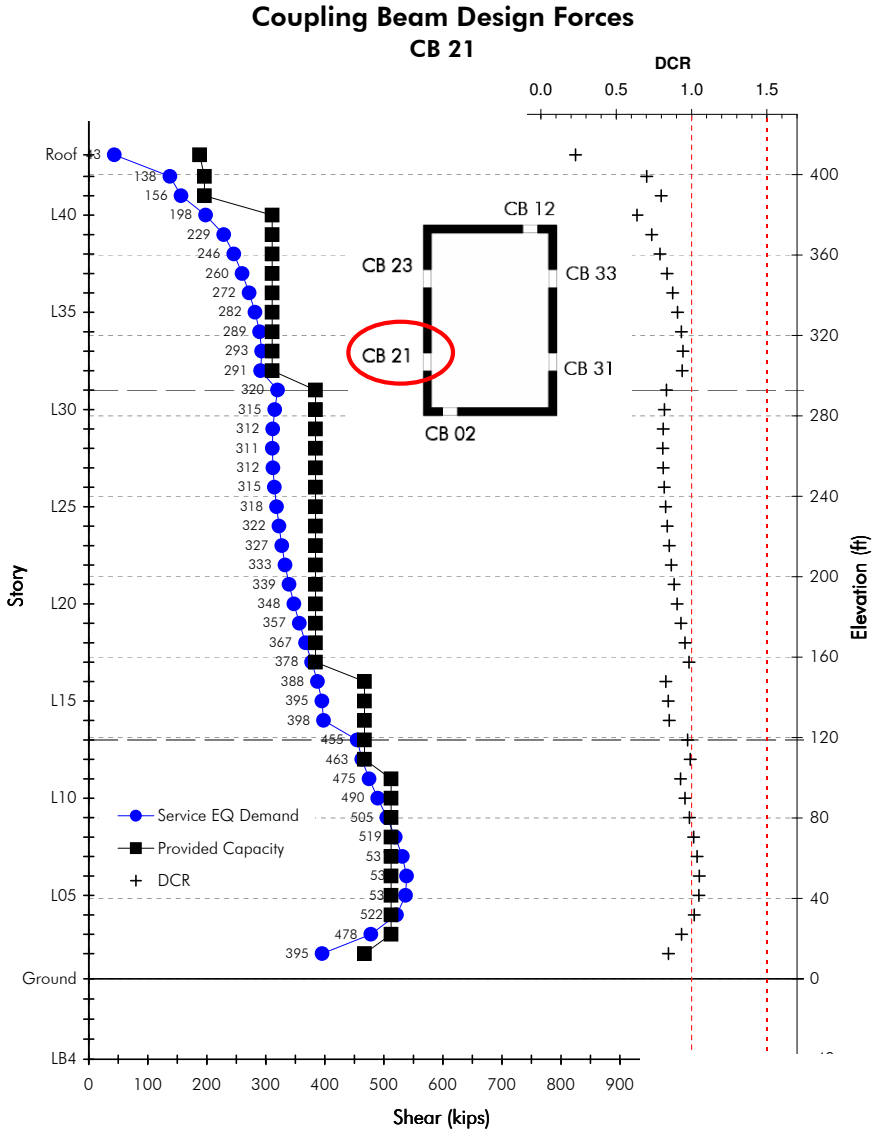

PEER TBI - Building 1B - Core Only Building for CSSC

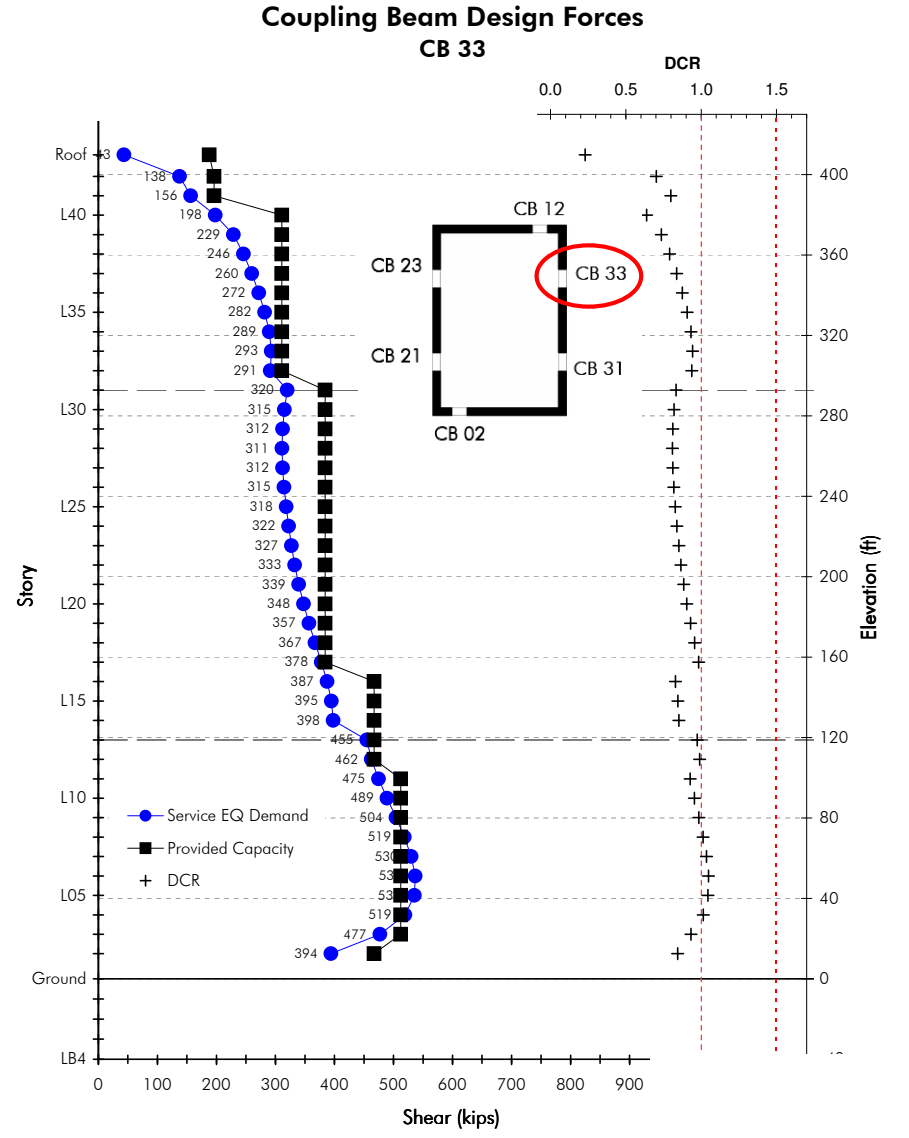

PEER TBI - Building 1B - Core Only Building for CSSC

Building 1B

Coupling Beam Design Forces CB 23

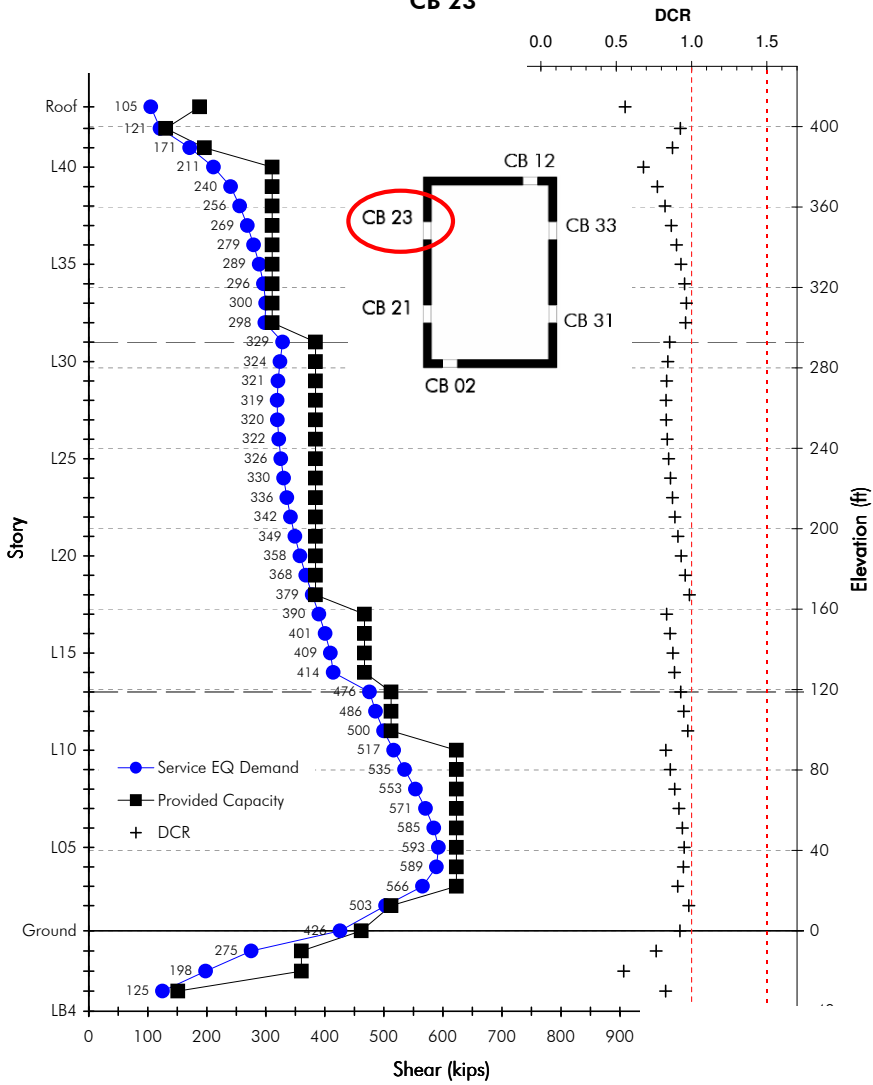

PEER TBI - Building 1B - Core Only Building for CSSC

Coupling Beam Design Forces CB 31

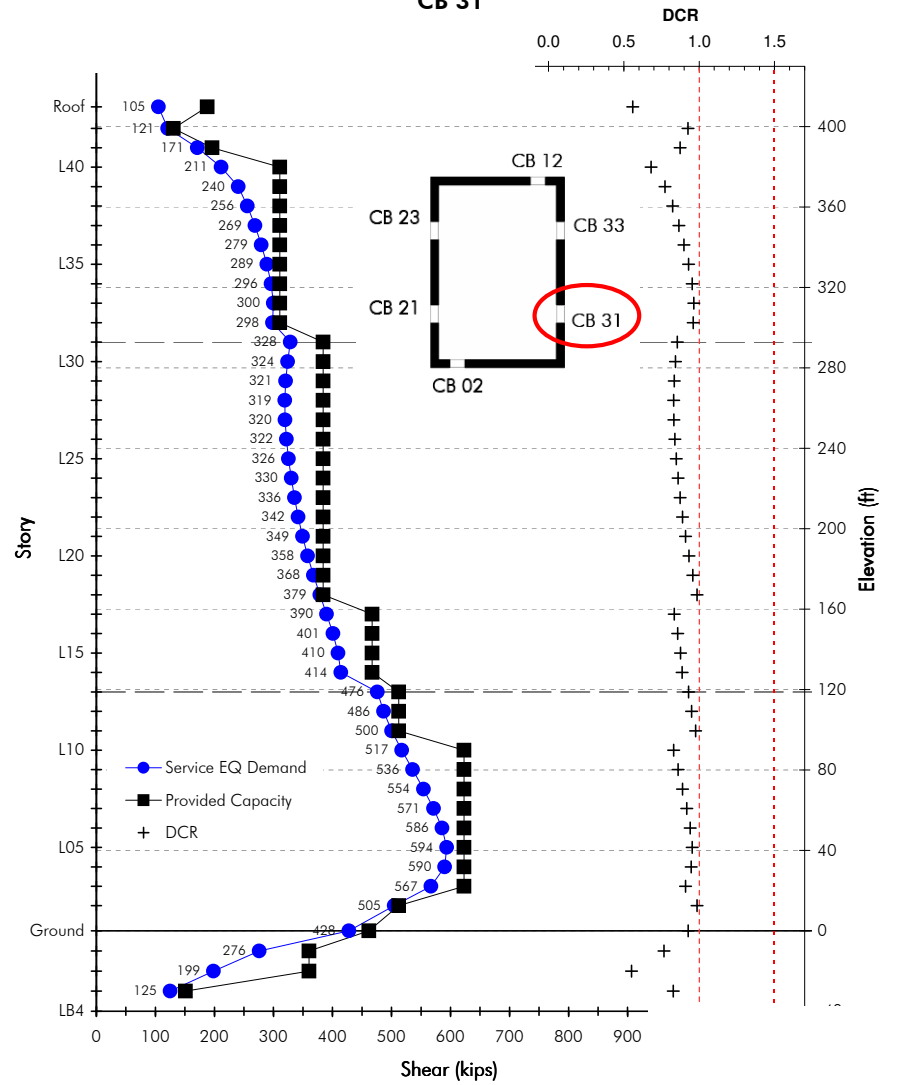

PEER TBI - Building 1B - Core Only Building for CSSC

Building 1C

Coupling Beam Design Forces CB 02

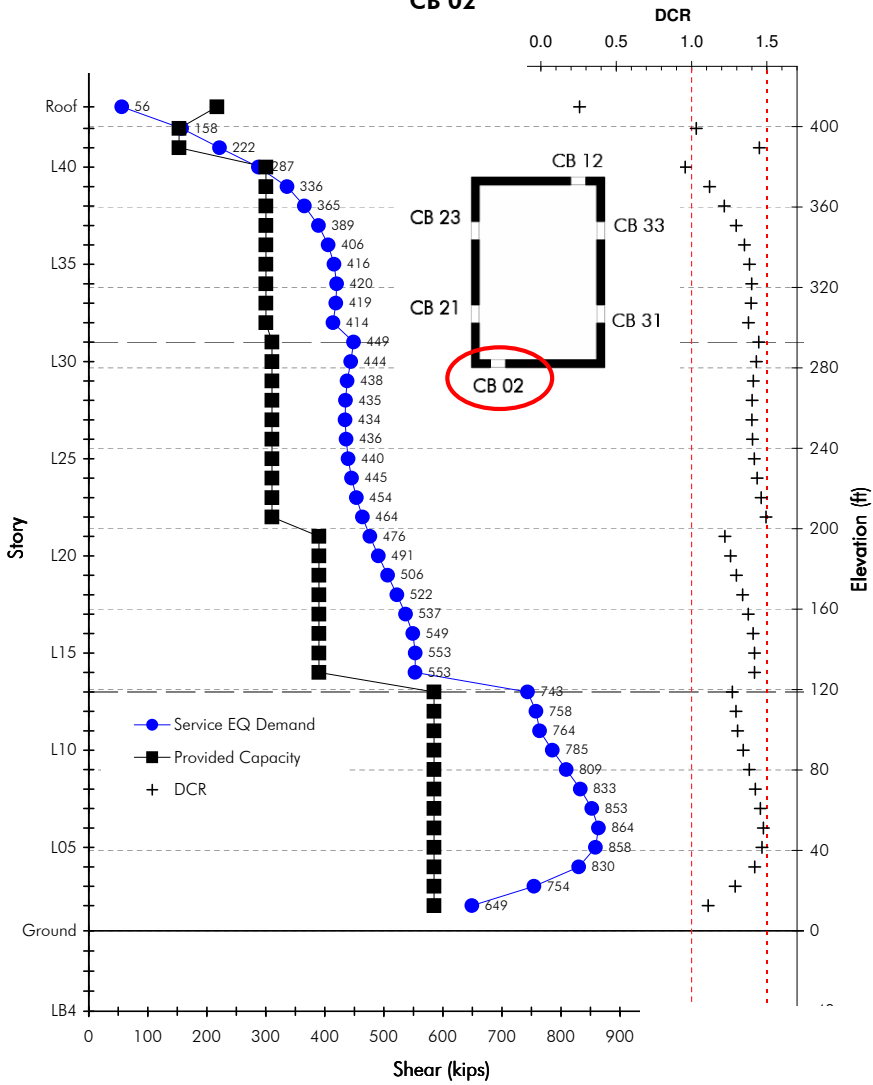

PEER TBI - Building 1C - Core Only Building for CSSC

Coupling Beam Design Forces CB 12

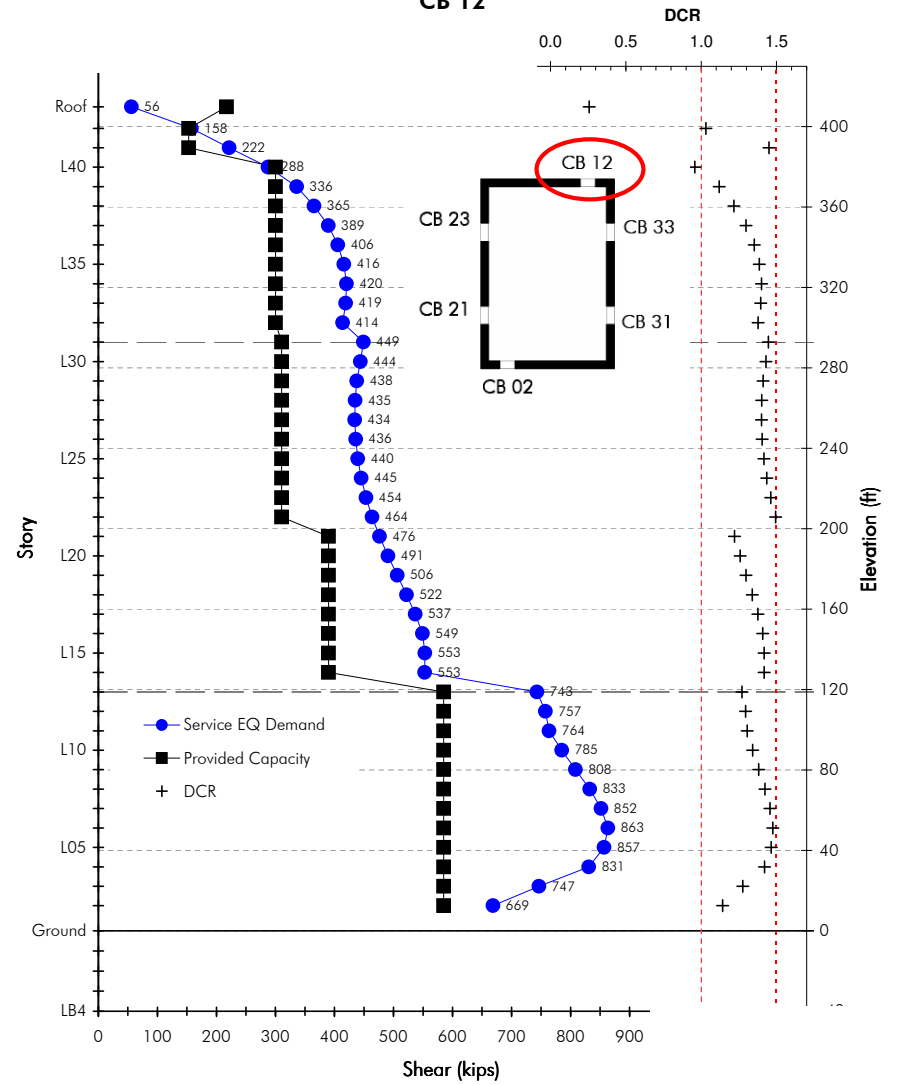

PEER TBI - Building 1C - Core Only Building for CSSC

Building 1C

Coupling Beam Design Forces CB 21

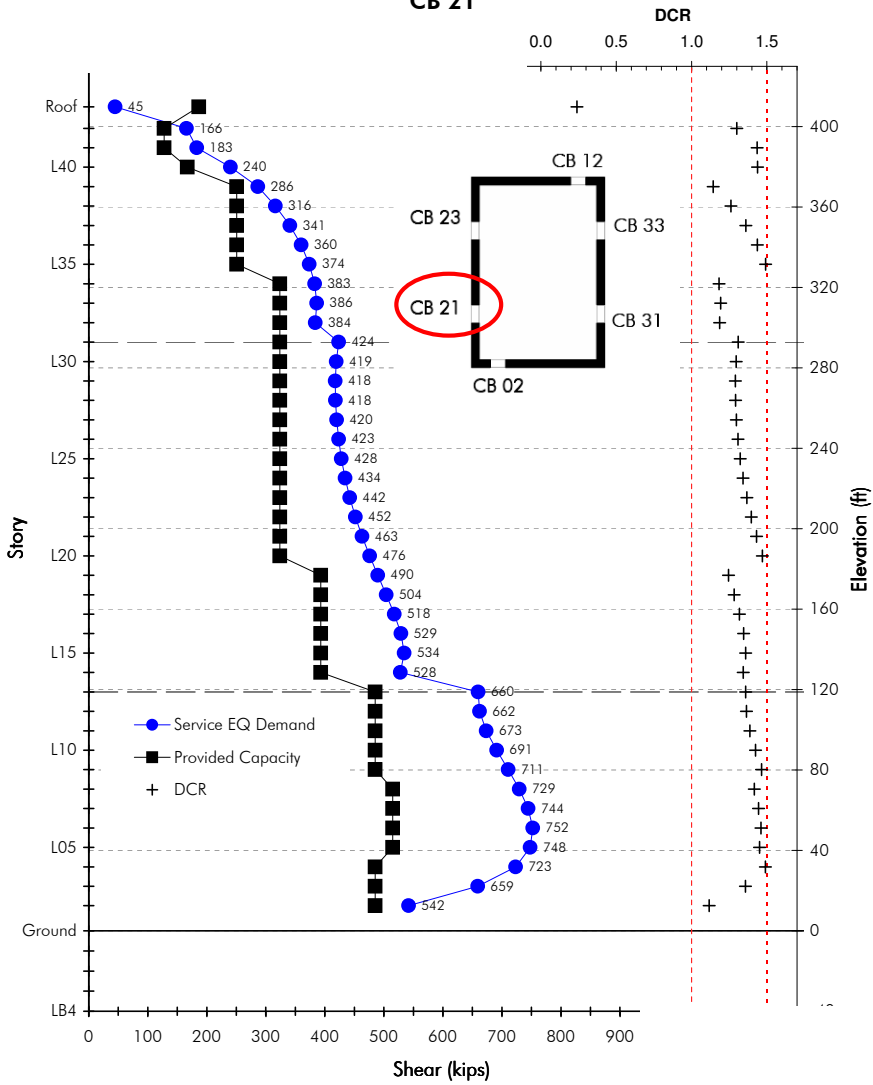

Coupling Beam Design Forces CB 33

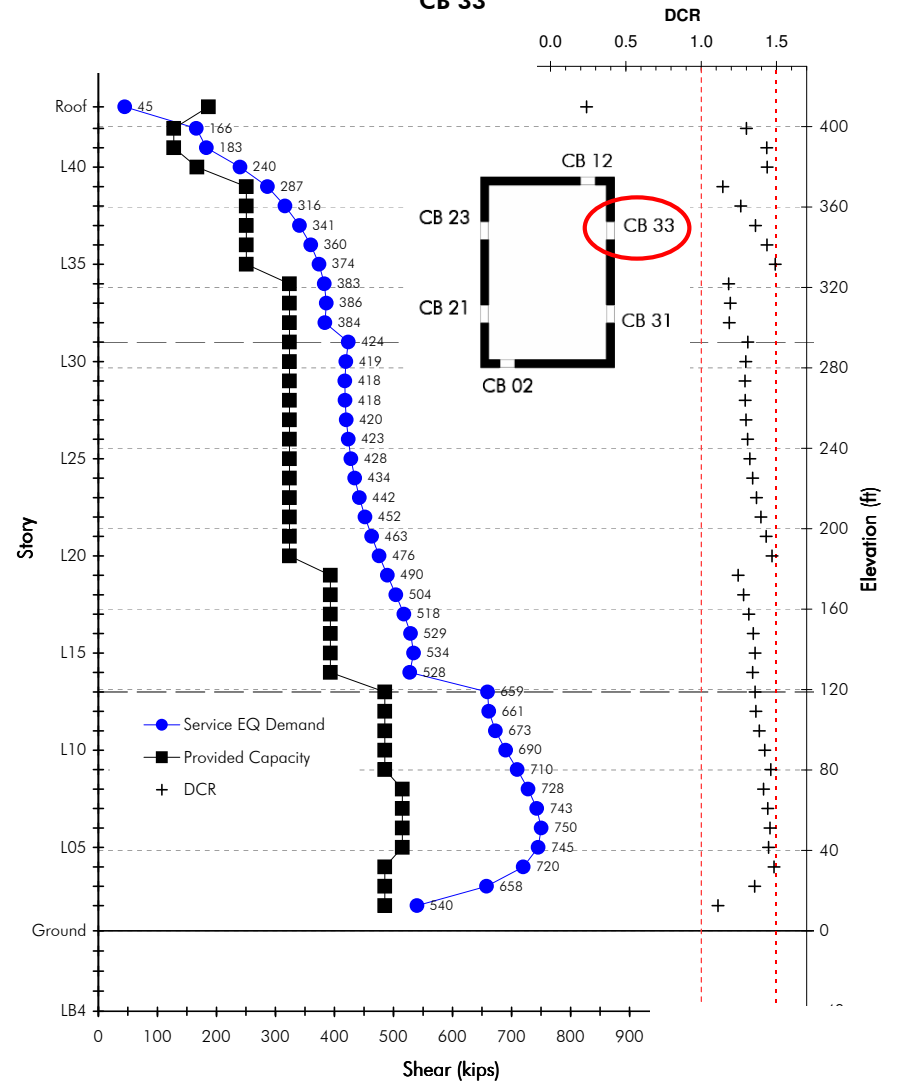

Building 1C

Coupling Beam Design Forces CB 23

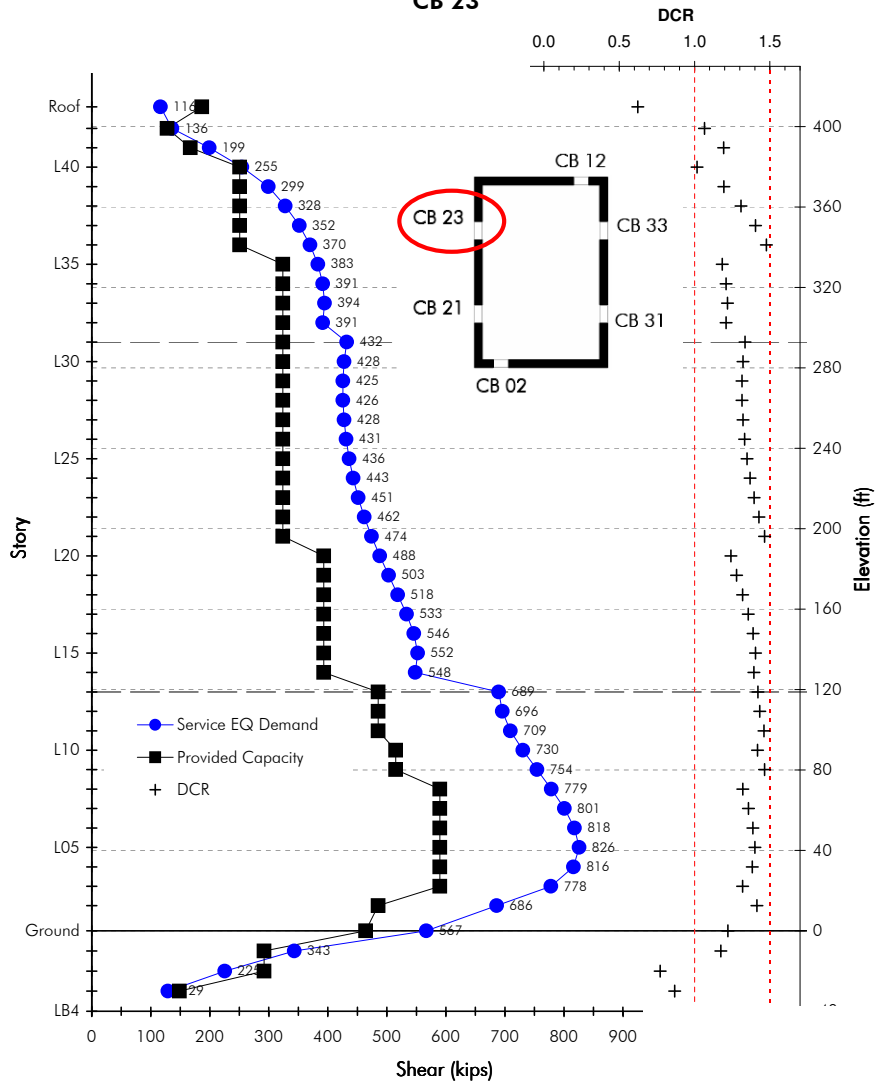

PEER TBI - Building 1C - Core Only Building for CSSC

Coupling Beam Design Forces CB 31

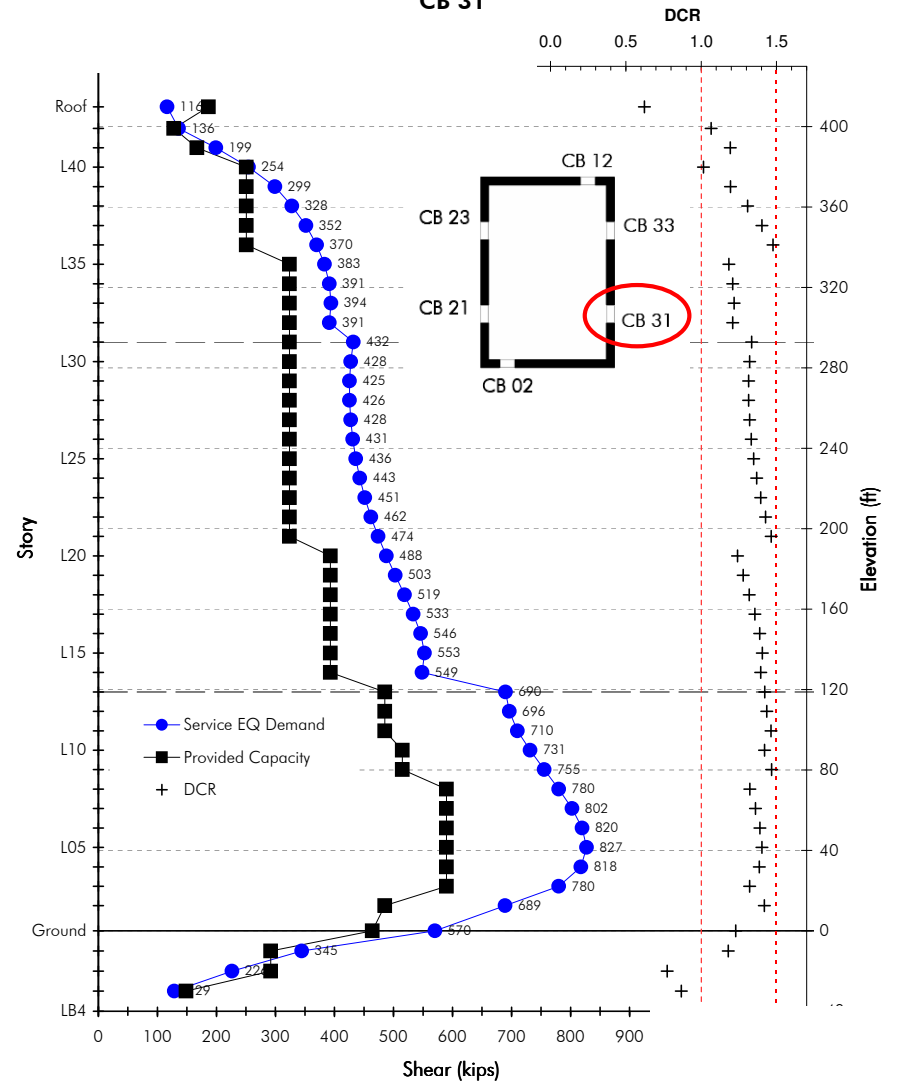

PEER TBI - Building 1C - Core Only Building for CSSC

APPENDIX 3
DRIFT PLOTS - MCE LEVEL
(BUILDINGS 1B AND 1C)



MAGNUSSON
KLEMENCIC
ASSOCIATES



Building 1B

Building Maximum Interstory Drift X Direction

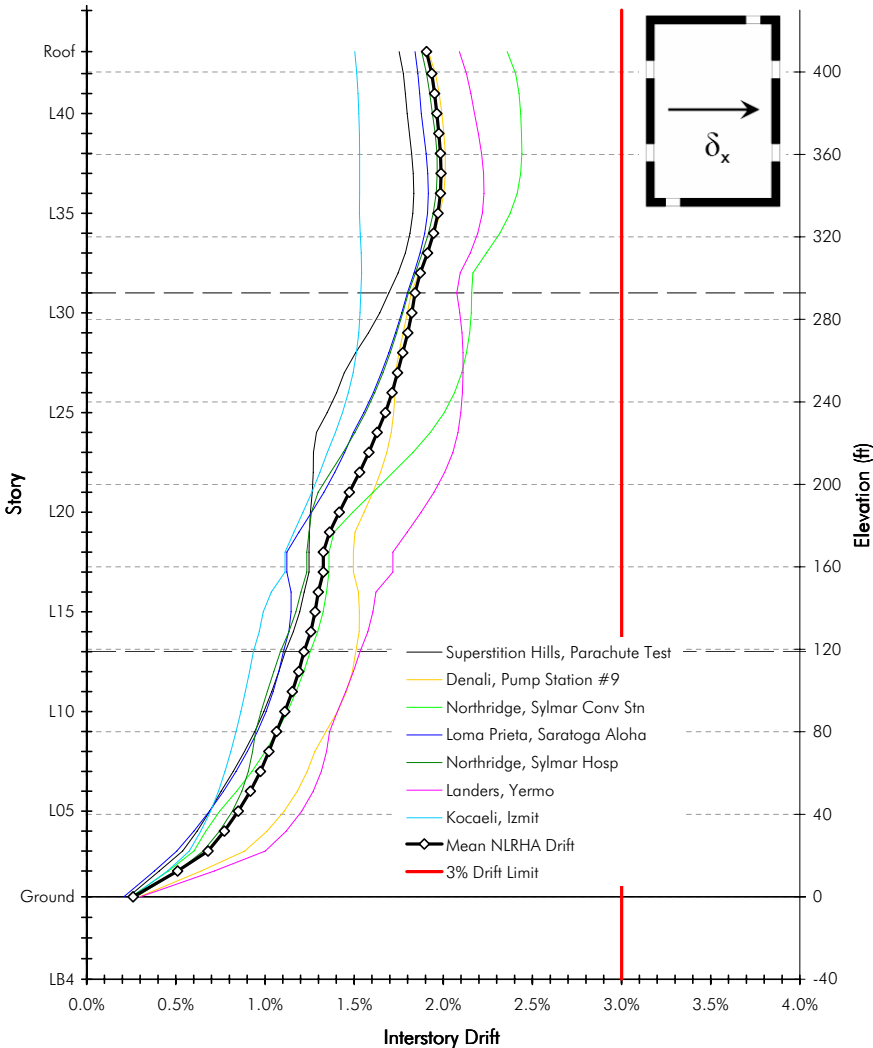

PEER TBI - Building 1B - Core Only Building for CSSC

Building Maximum Interstory Drift Y Direction

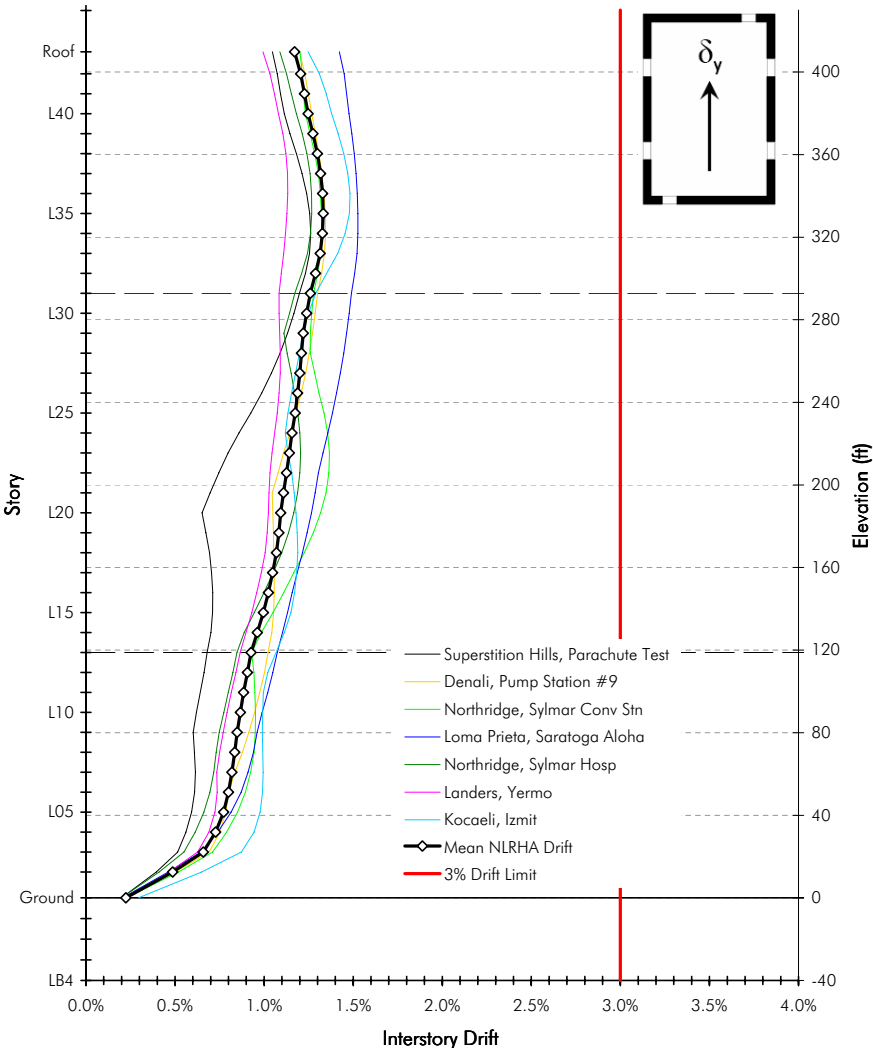

PEER TBI - Building 1B - Core Only Building for CSSC

Building 1C

Building Maximum Interstory Drift X Direction

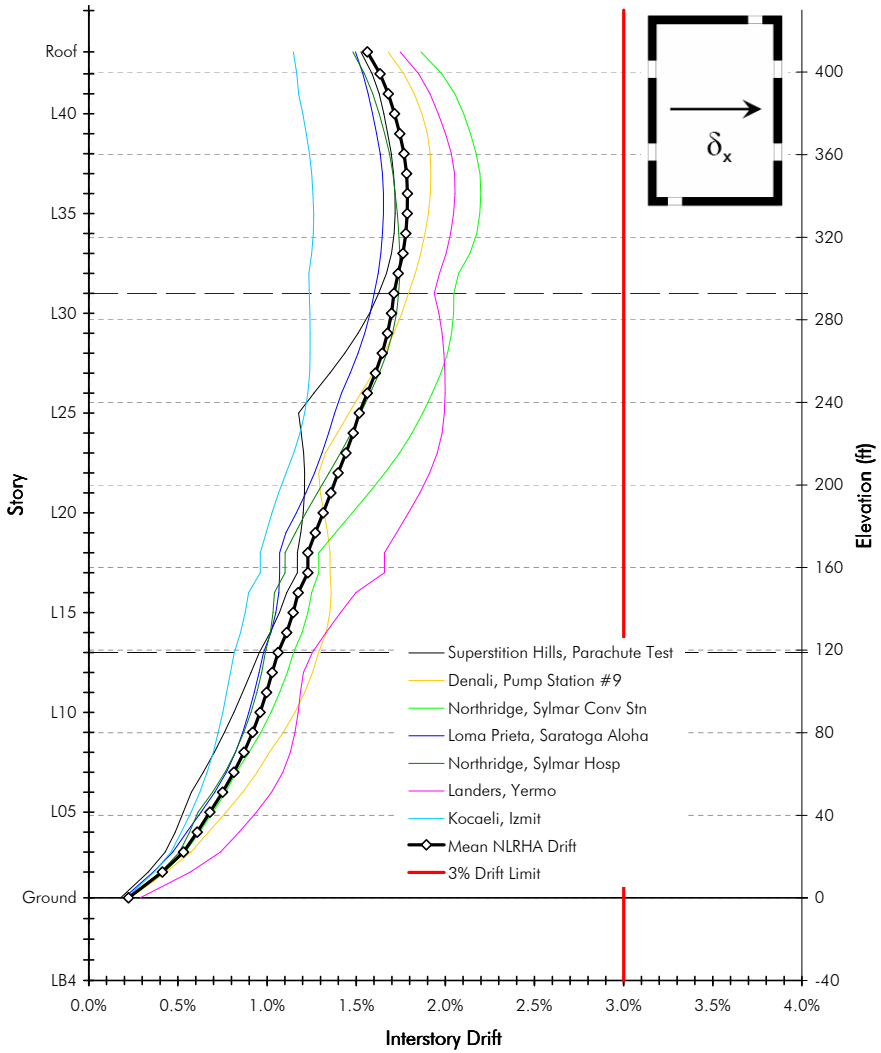

PEER TBI - Building 1C - Core Only Building for CSSC

Building Maximum Interstory Drift Y Direction

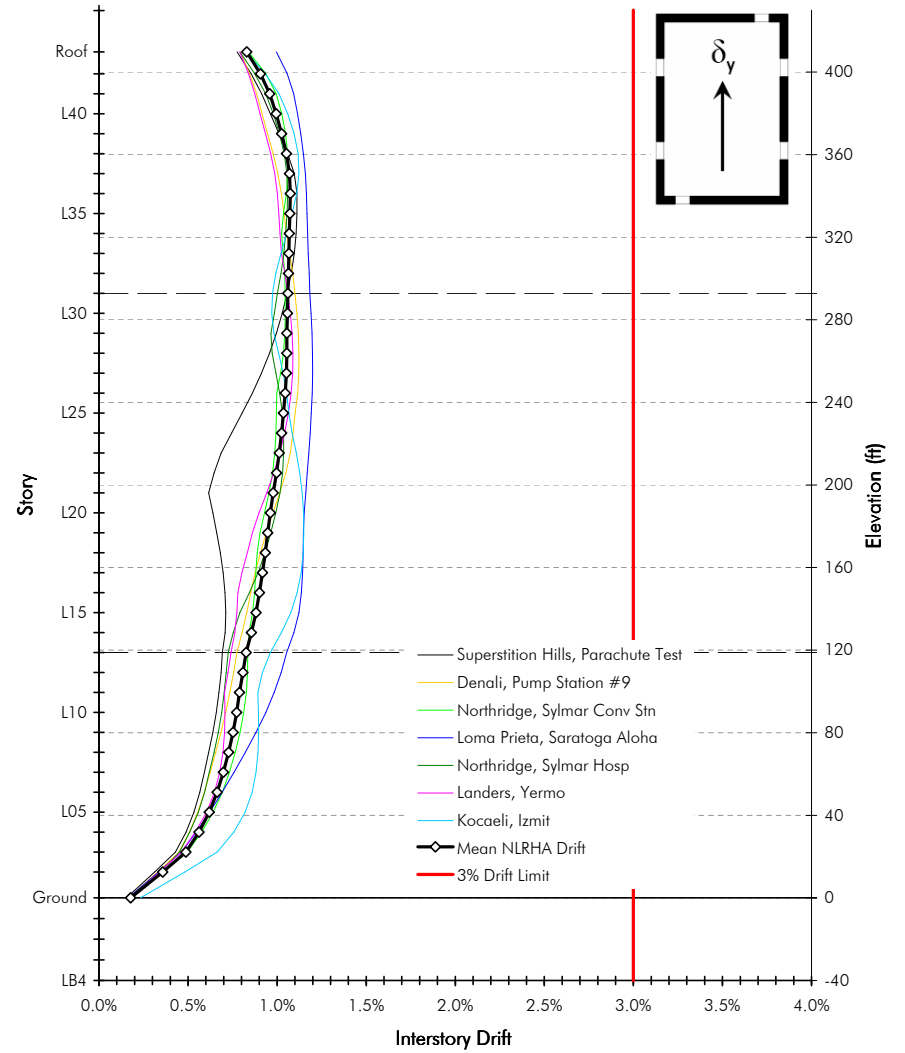

PEER TBI - Building 1C - Core Only Building for CSSC

APPENDIX 4
SHEAR AND OVERTURNING PLOTS -
MCE LEVEL
(BUILDINGS 1B AND 1C)



MAGNUSSON
KLEMENCIC
ASSOCIATES



Building 1B

Accumulated Core Shear X Direction

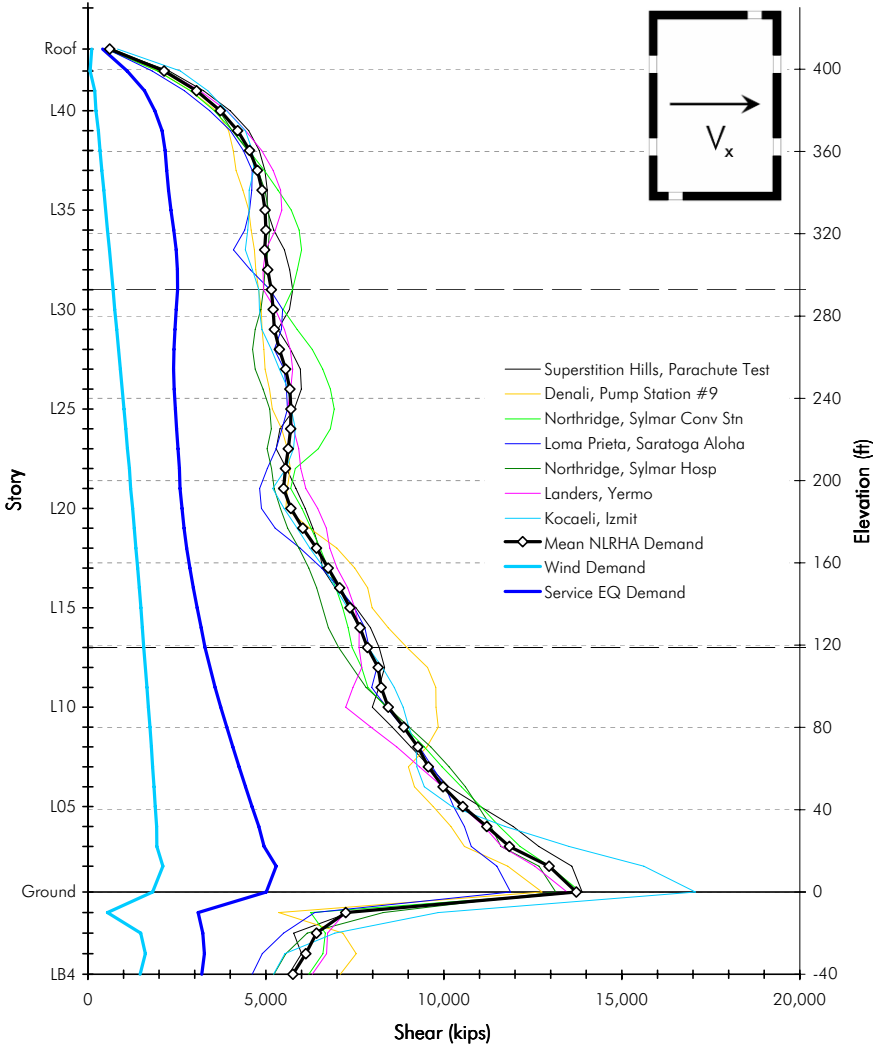

PEER TBI - Building 1B - Core Only Building for CSSC

Accumulated Core Shear Y Direction

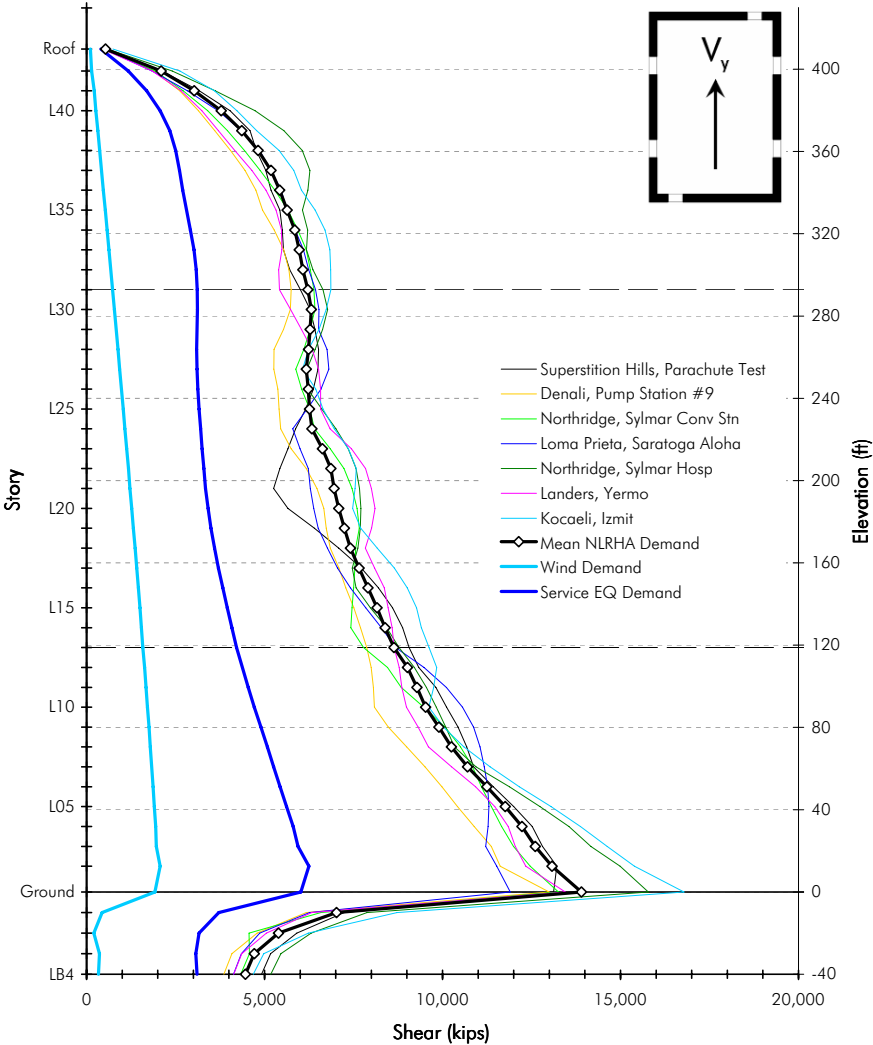

PEER TBI - Building 1B - Core Only Building for CSSC

Building 1C

**Accumulated Core Shear
Lateral Load in X Direction**

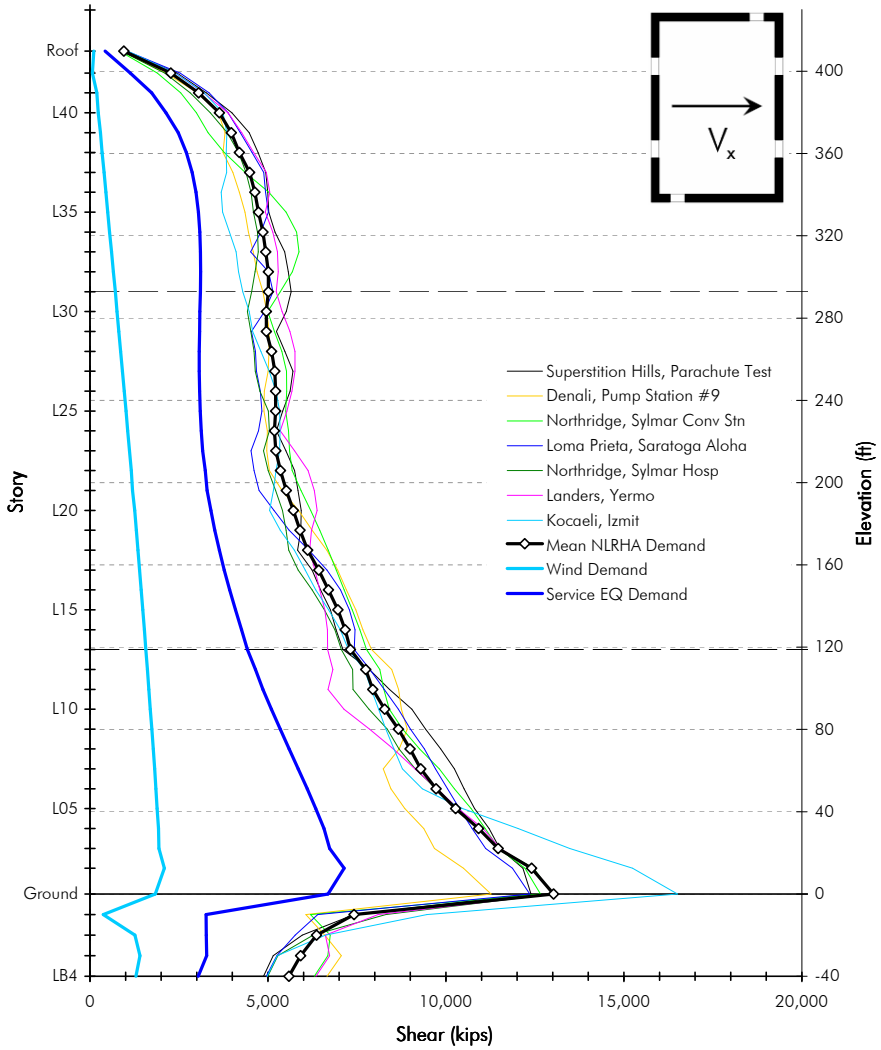

PEER TBI - Building 1C - Core Only Building for CSSC

**Accumulated Core Shear
Lateral Load in Y Direction**

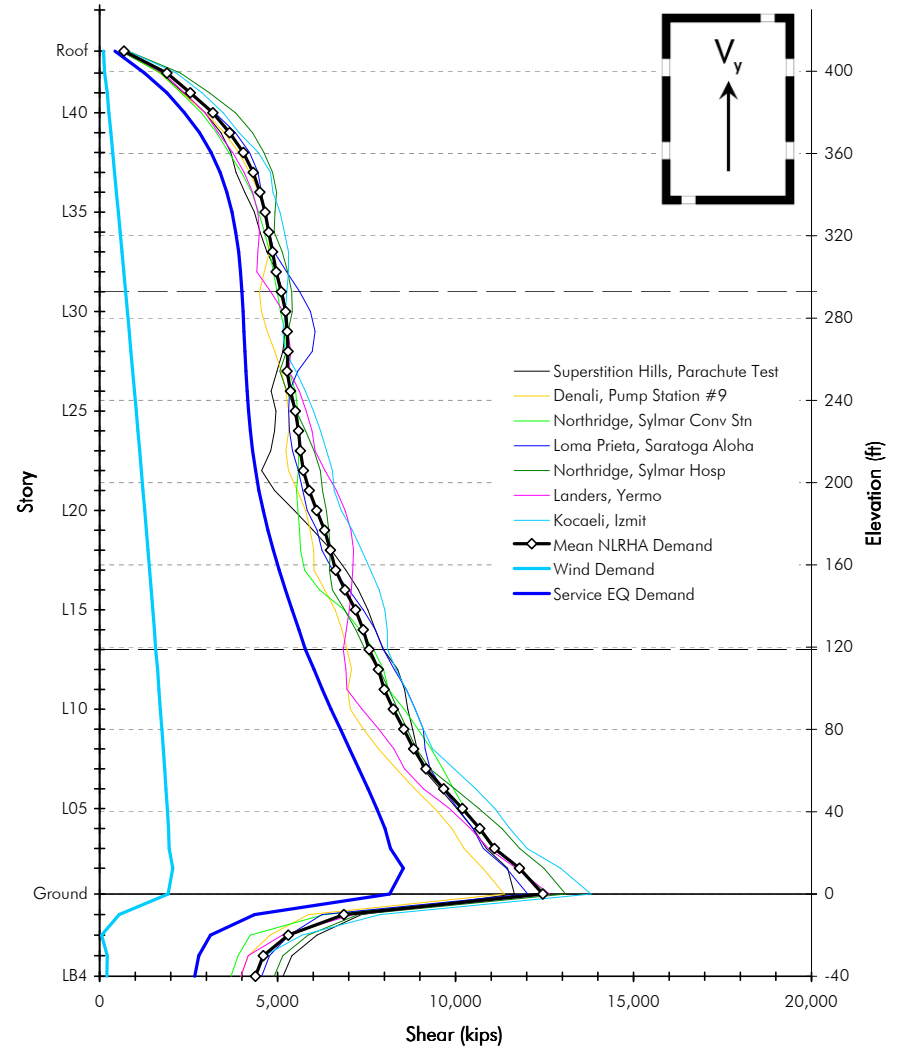

PEER TBI - Building 1C - Core Only Building for CSSC

Building 1B

Overturning Moment X Direction

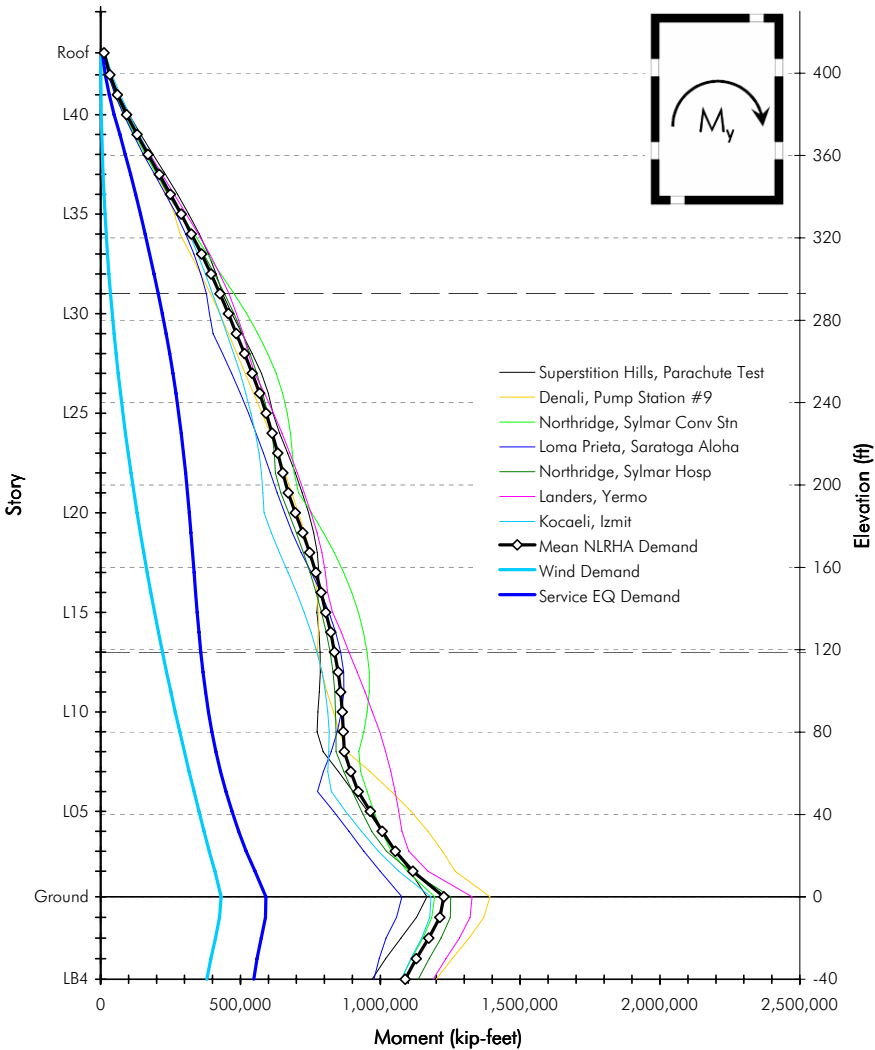

PEER TBI - Building 1B - Core Only Building for CSSC

Overturning Moment Y Direction

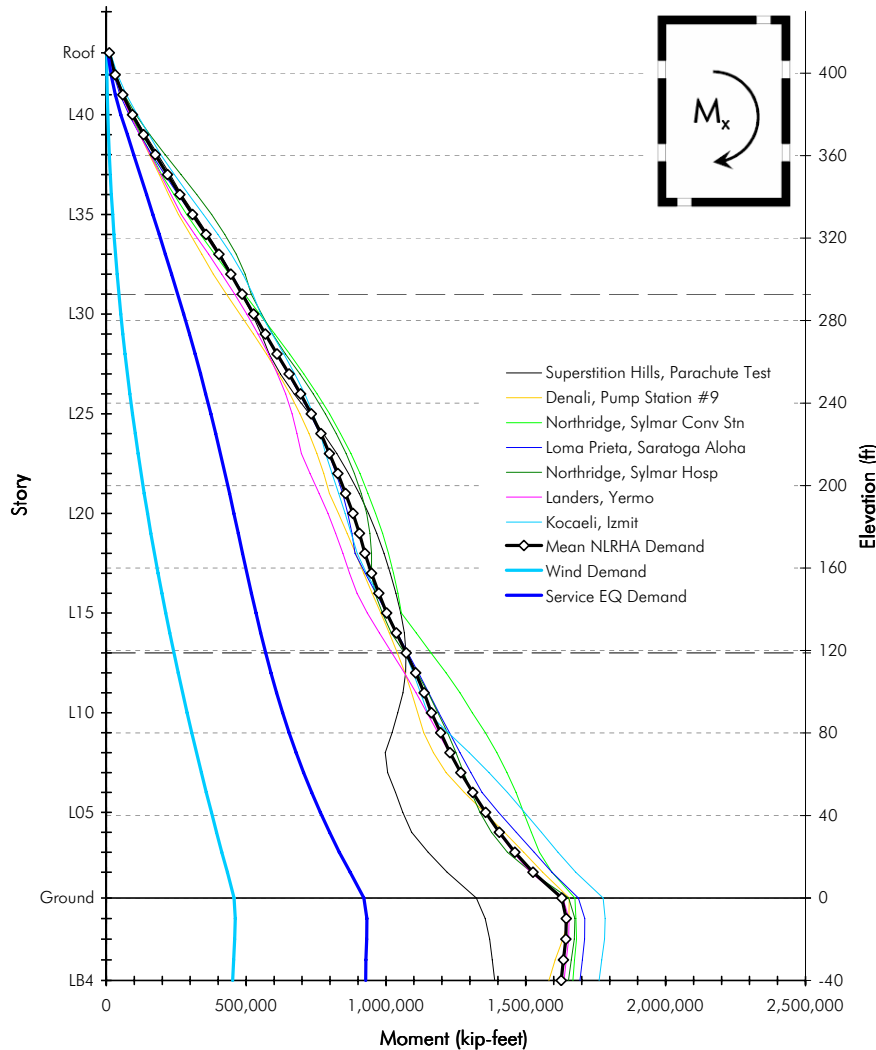

PEER TBI - Building 1B - Core Only Building for CSSC

Building 1C

Overturning Moment Lateral Load in X Direction

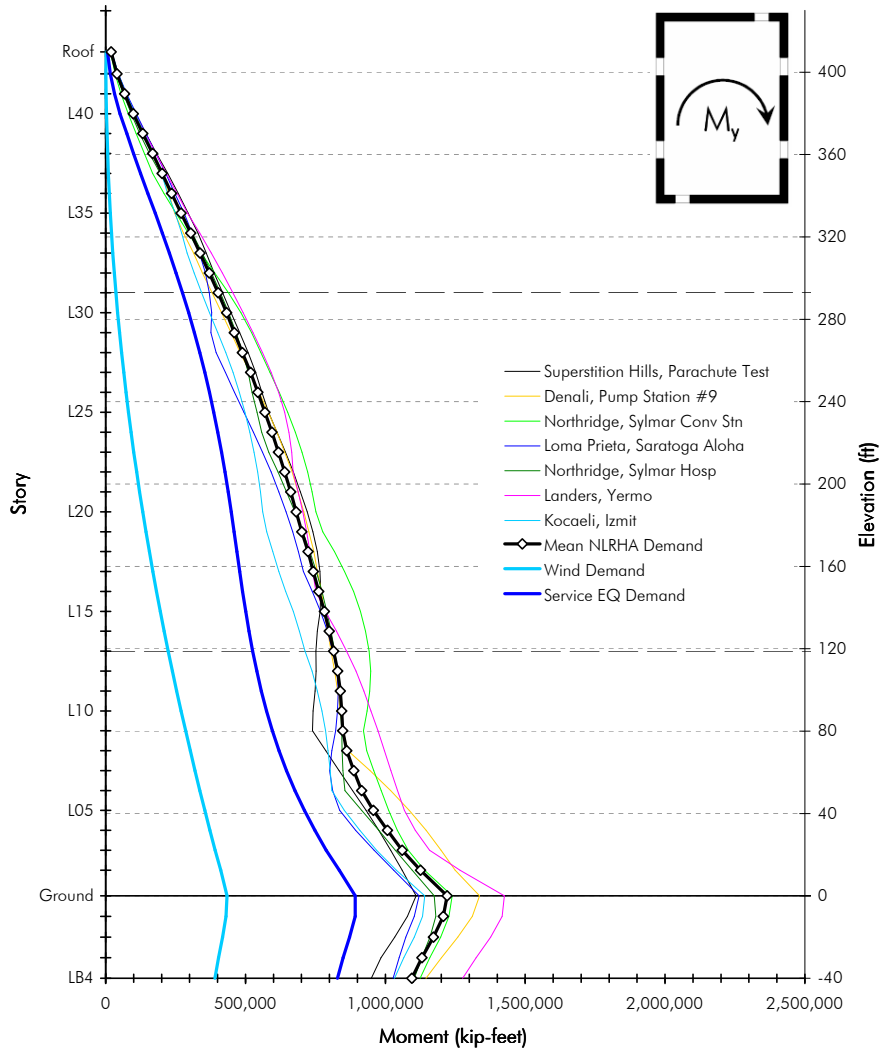

PEER TBI - Building 1C - Core Only Building for CSSC

Overturning Moment Lateral Load in Y Direction

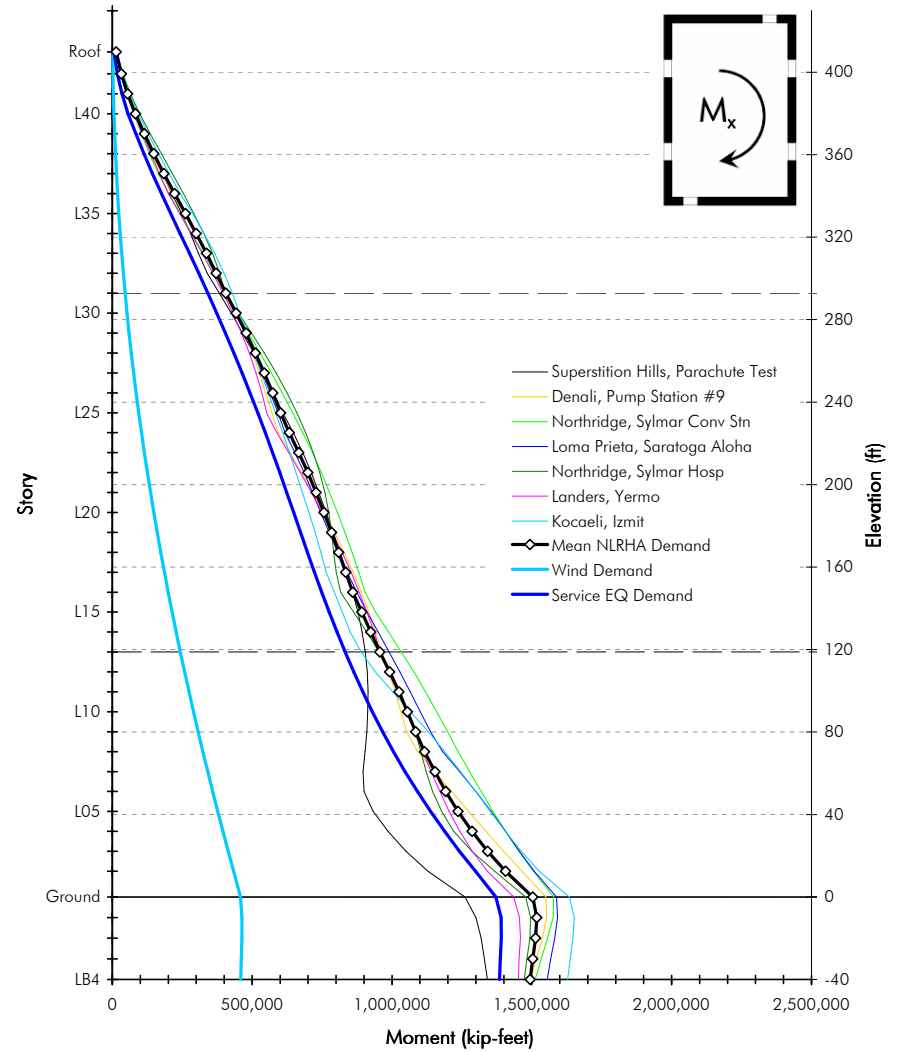

PEER TBI - Building 1C - Core Only Building for CSSC

APPENDIX 5
COUPLING BEAM ROTATIONS - MCE LEVEL
(BUILDINGS 1B AND 1C)



MAGNUSSON
KLEMENCIC
ASSOCIATES



Building 1B

Coupling Beam Rotations CB 02

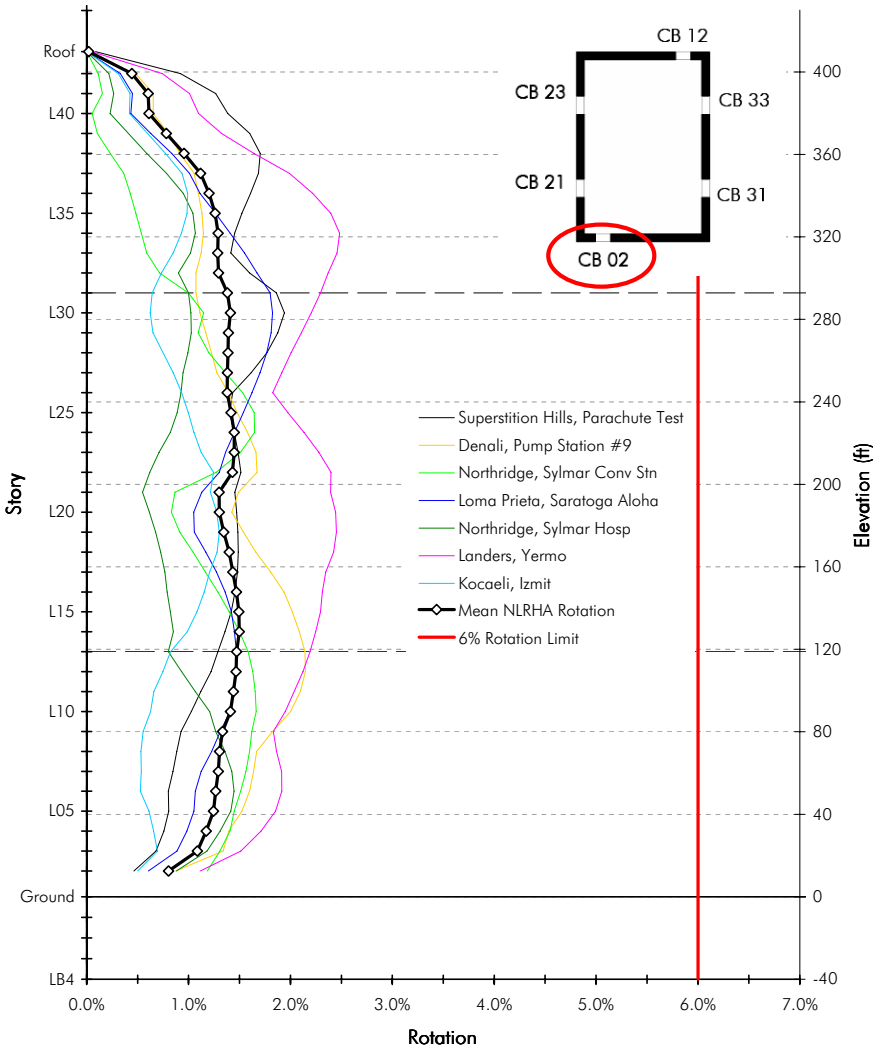

PEER TBI - Building 1B - Core Only Building for CSSC

Coupling Beam Rotations CB 12

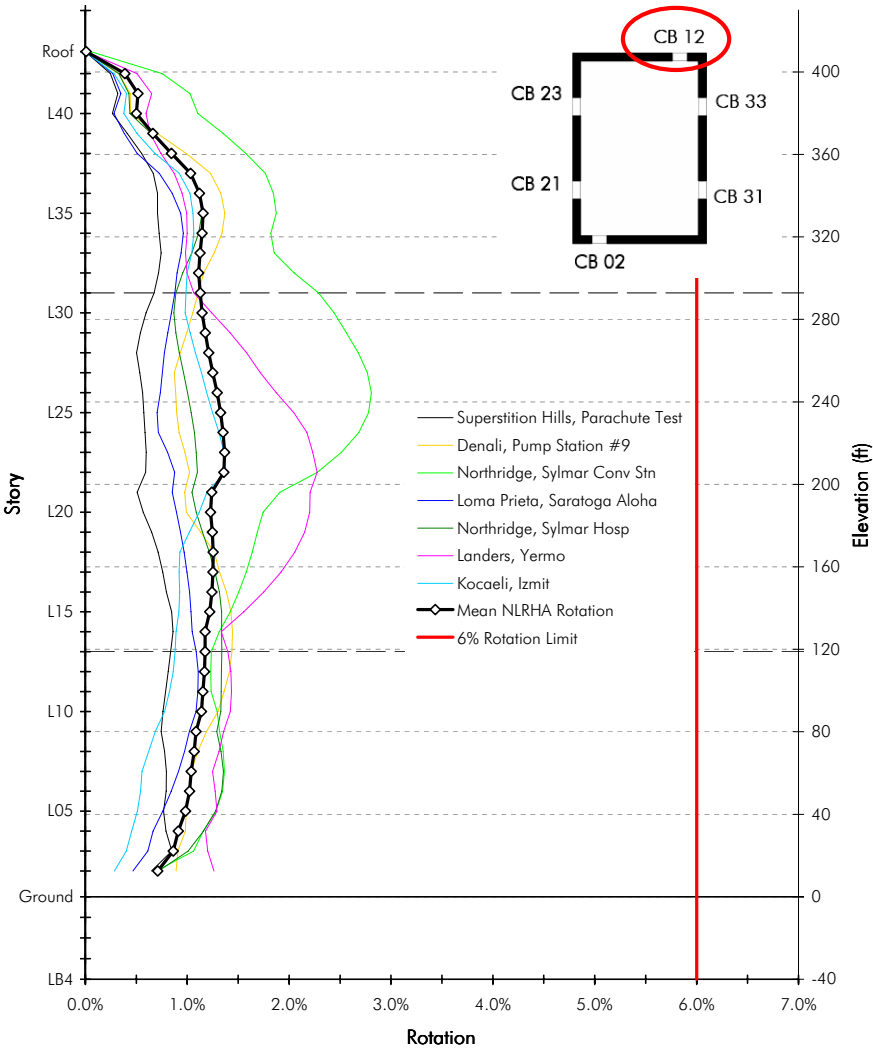

PEER TBI - Building 1B - Core Only Building for CSSC

Building 1C

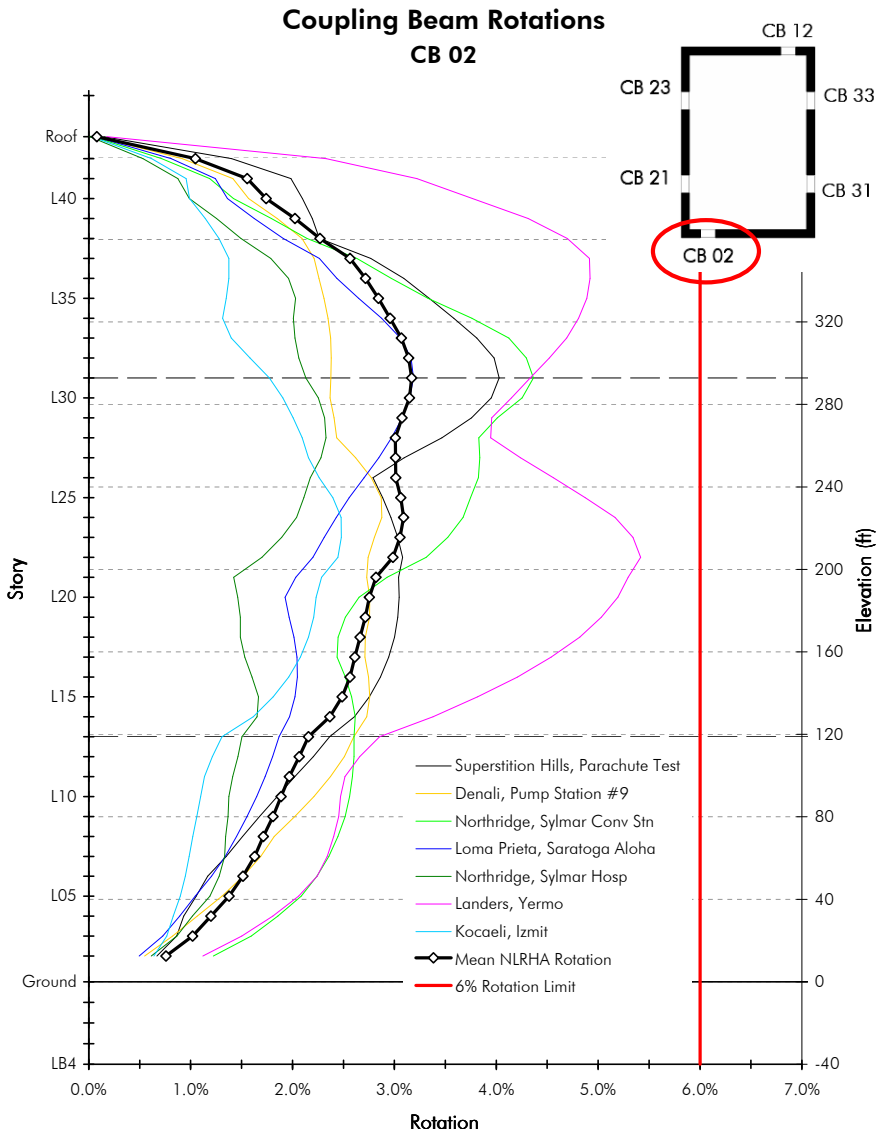

PEER TBI - Building 1C - Core Only Building for CSSC

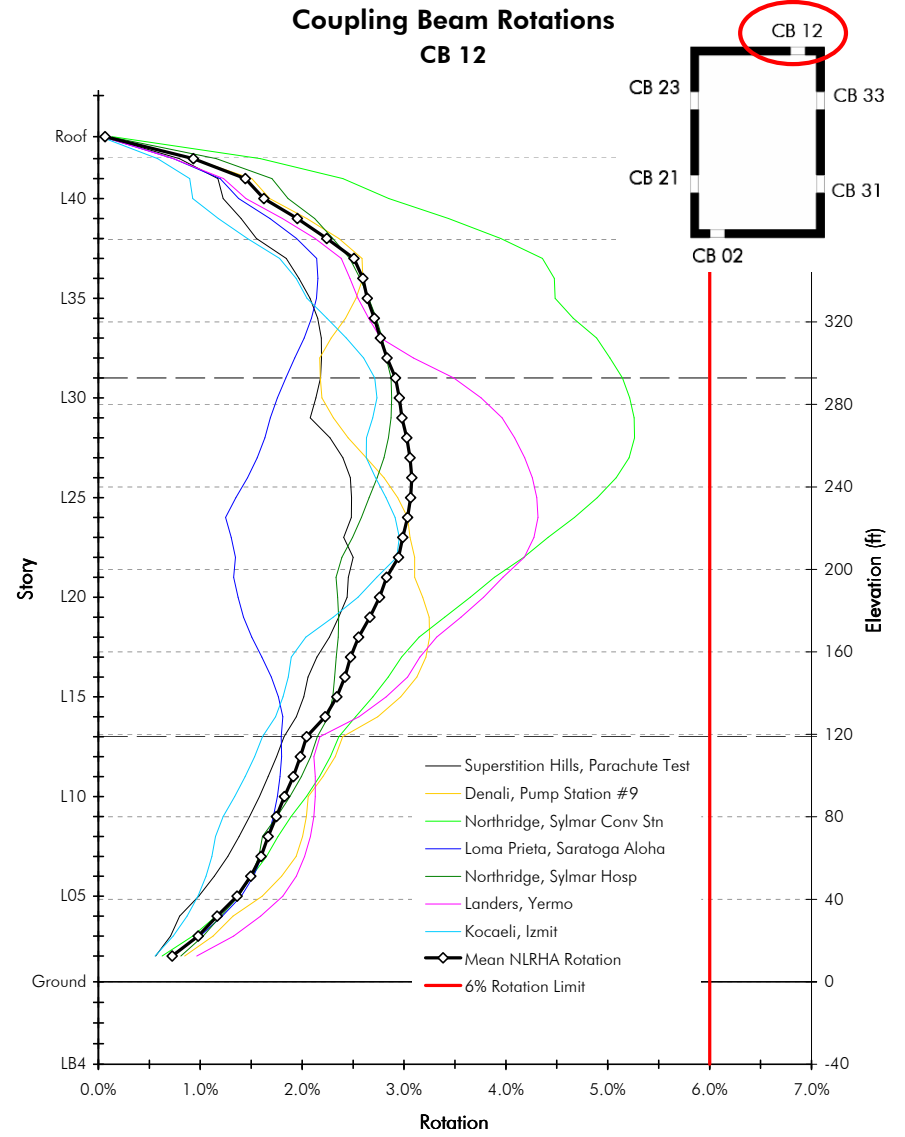

PEER TBI - Building 1C - Core Only Building for CSSC

Building 1B

Coupling Beam Rotations CB 21

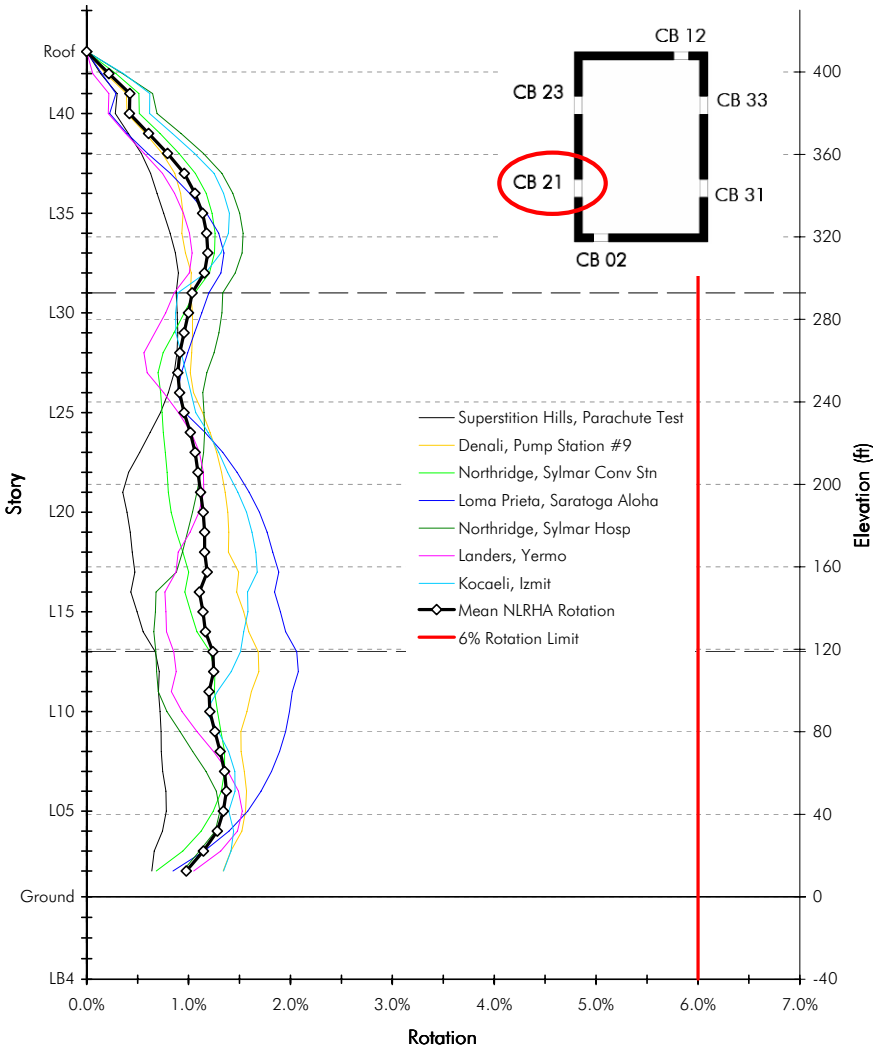

PEER TBI - Building 1B - Core Only Building for CSSC

Coupling Beam Rotations CB 33

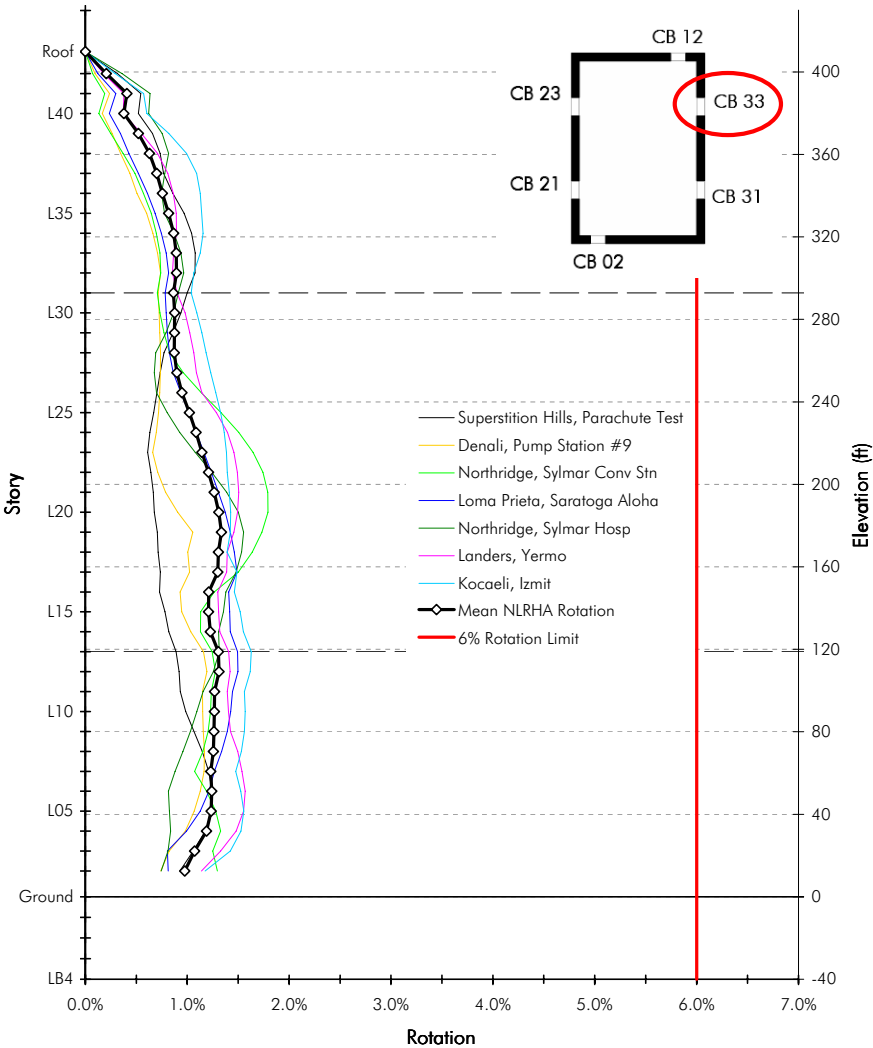

PEER TBI - Building 1B - Core Only Building for CSSC

Building 1C

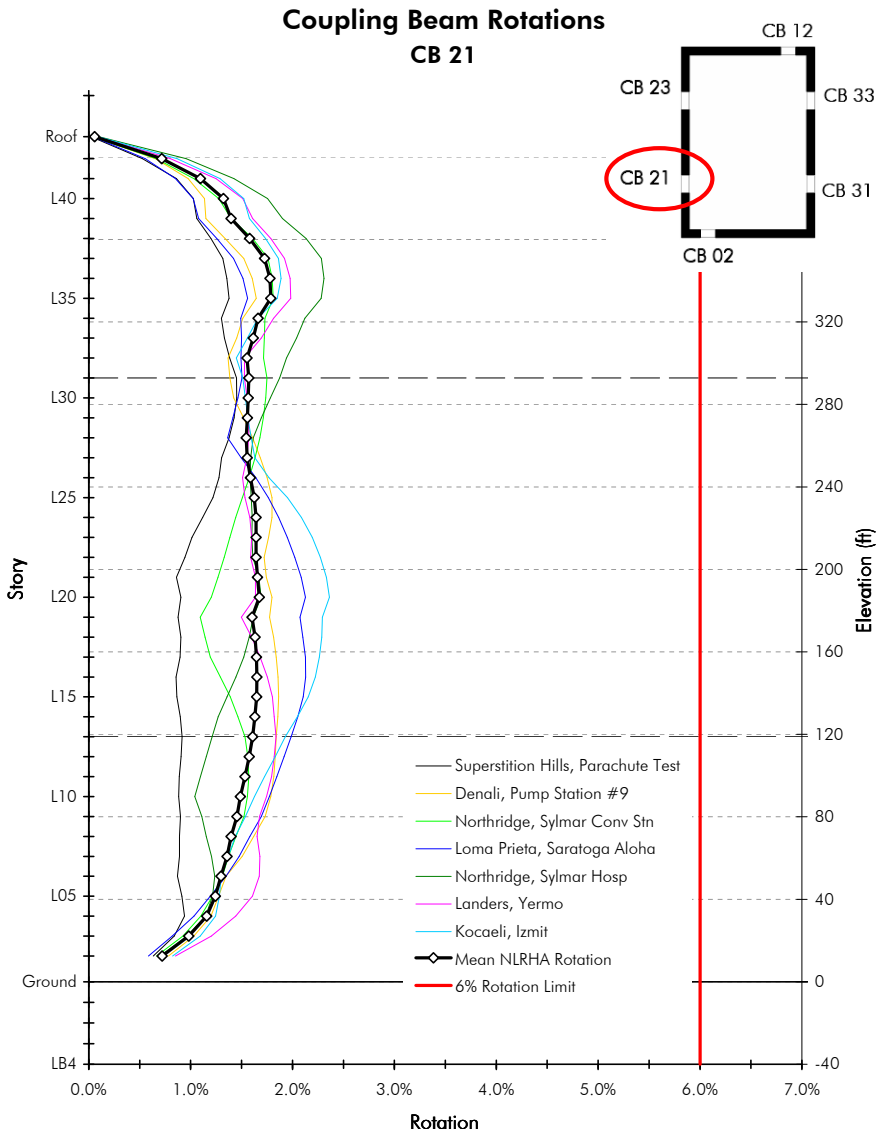

PEER TBI - Building 1C - Core Only Building for CSSC

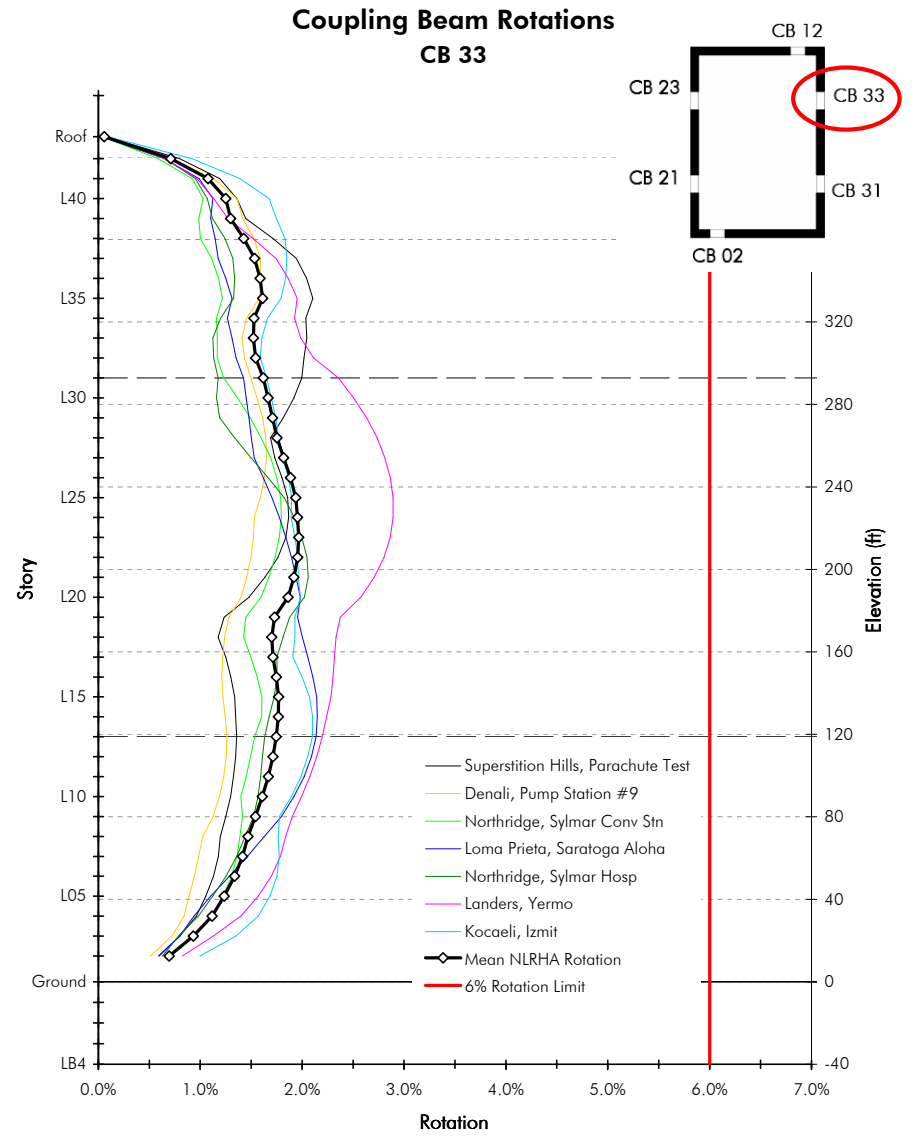

PEER TBI - Building 1C - Core Only Building for CSSC

Building 1B

Coupling Beam Rotations CB 23

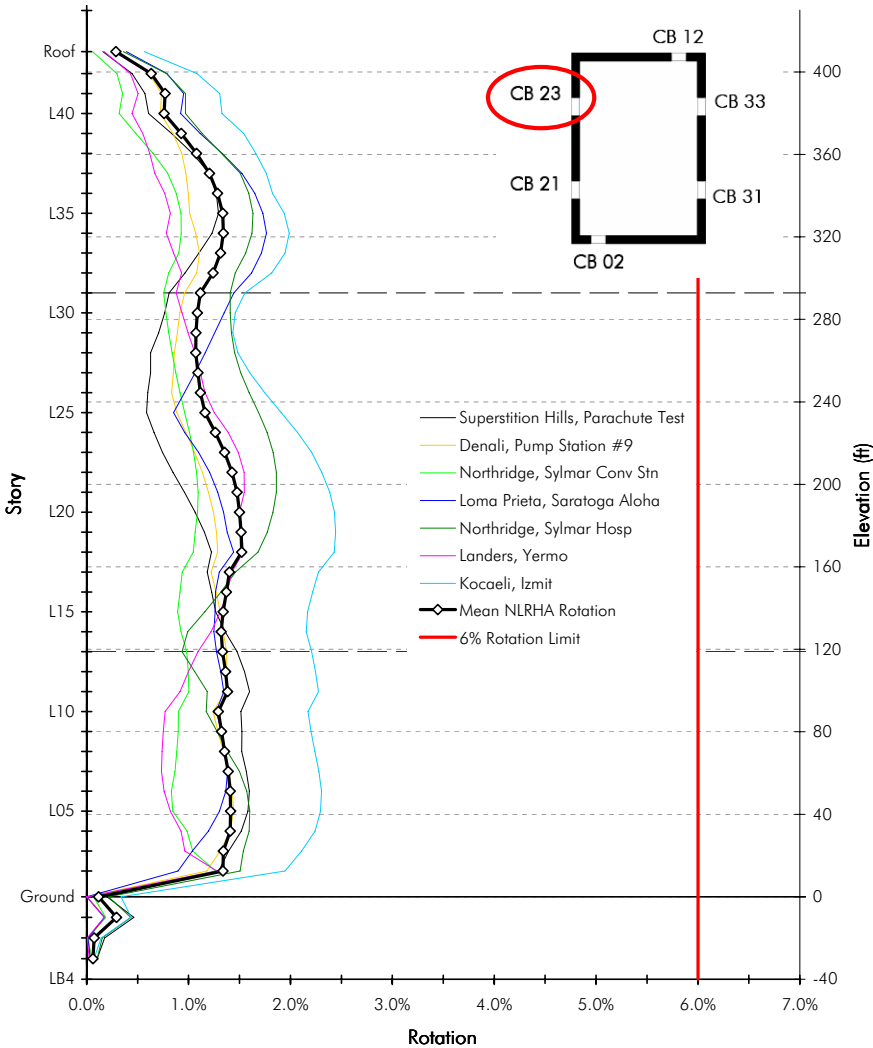

PEER TBI - Building 1B - Core Only Building for CSSC

Coupling Beam Rotations CB 31

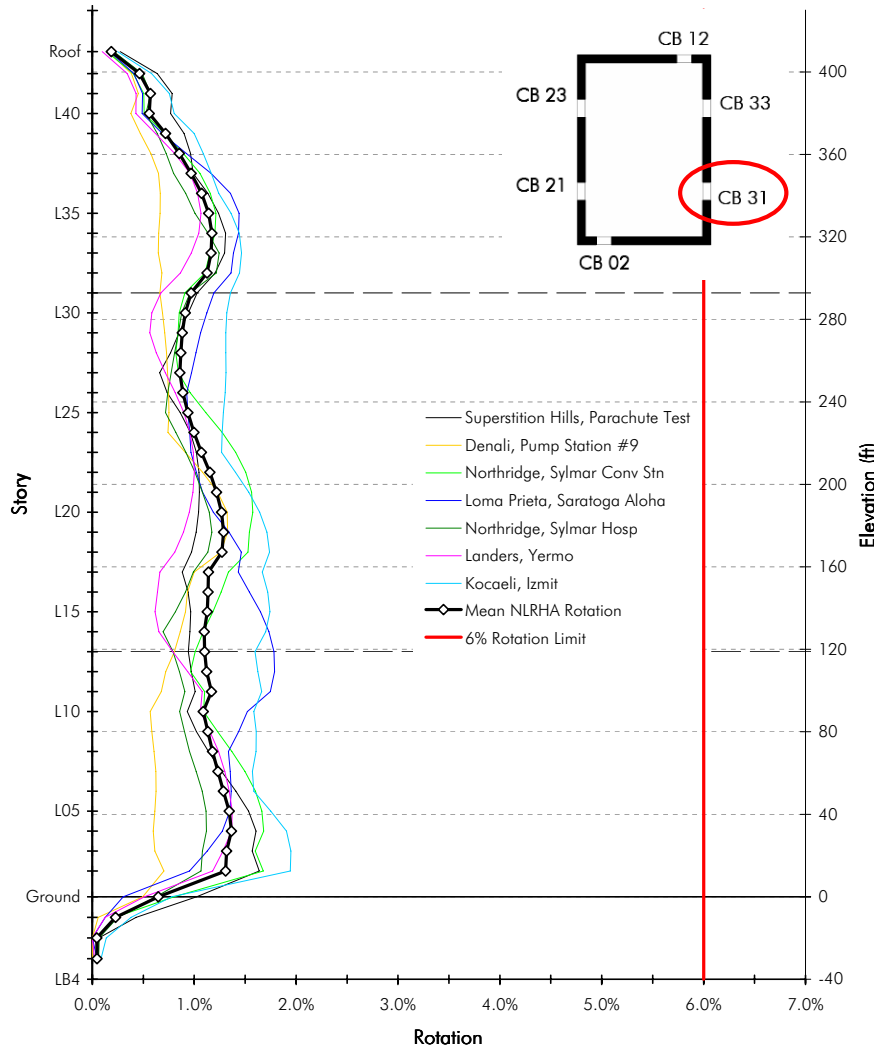

PEER TBI - Building 1B - Core Only Building for CSSC

Building 1C

Coupling Beam Rotations CB 23

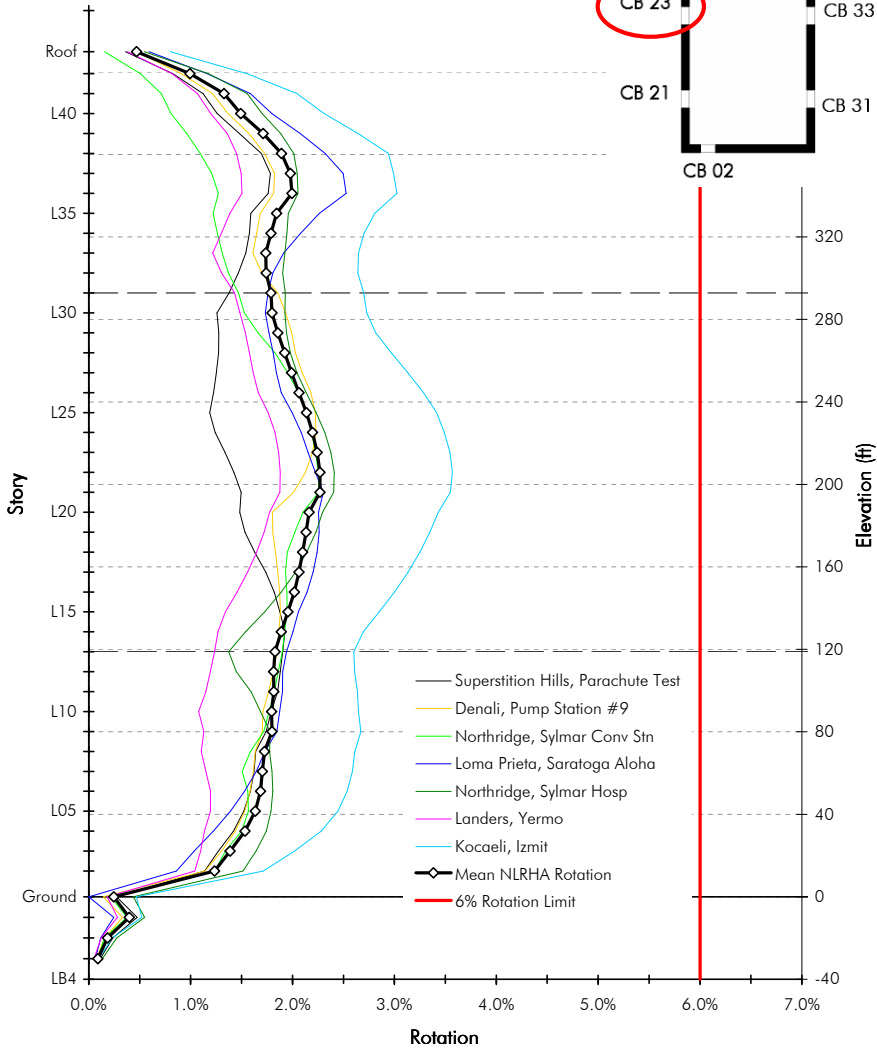
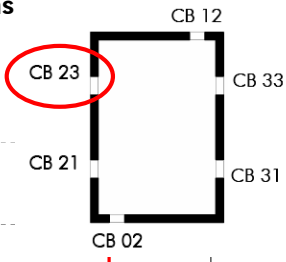

PEER TBI - Building 1C - Core Only Building for CSSC

Coupling Beam Rotations CB 31

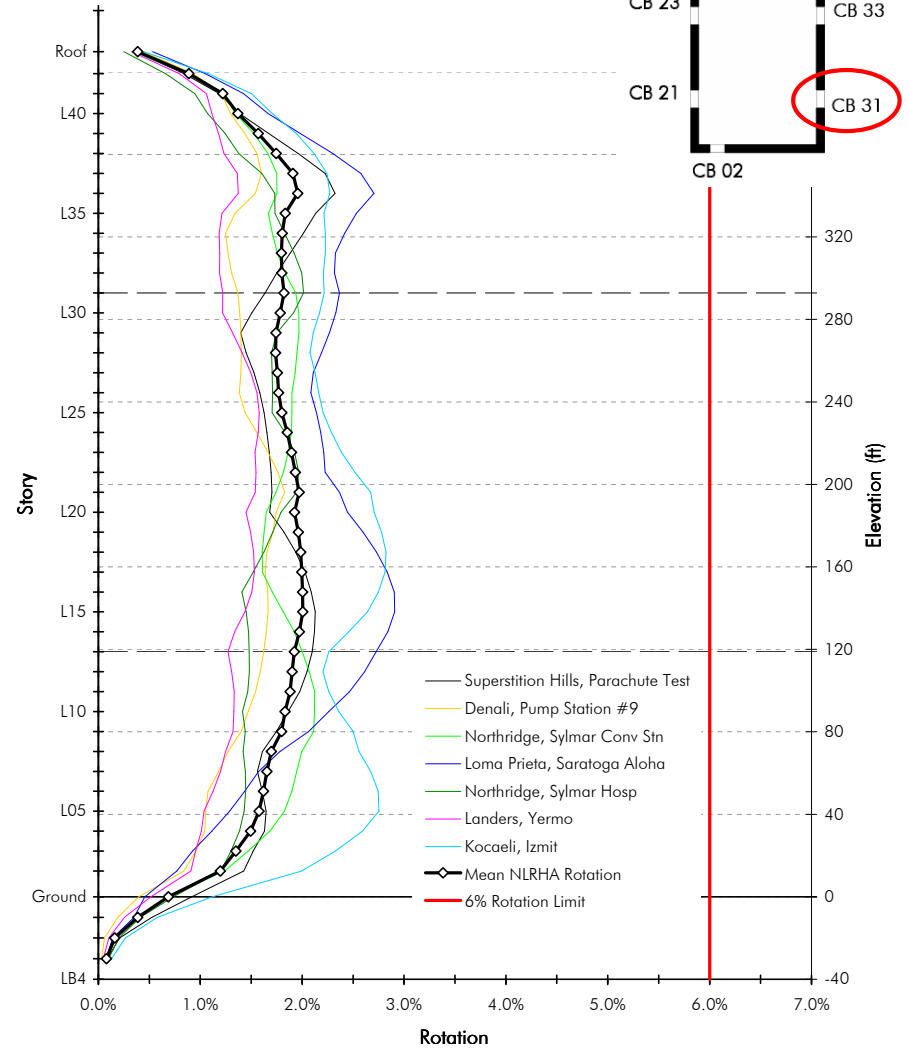
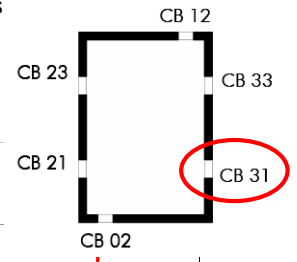

PEER TBI - Building 1C - Core Only Building for CSSC

APPENDIX 6
COMPRESSION AND TENSION STRAINS -
MCE LEVEL
(BUILDINGS 1B AND 1C)



MAGNUSSON
KLEMENCIC
ASSOCIATES



Building 1B

Core Wall Compression Strains SW Corner

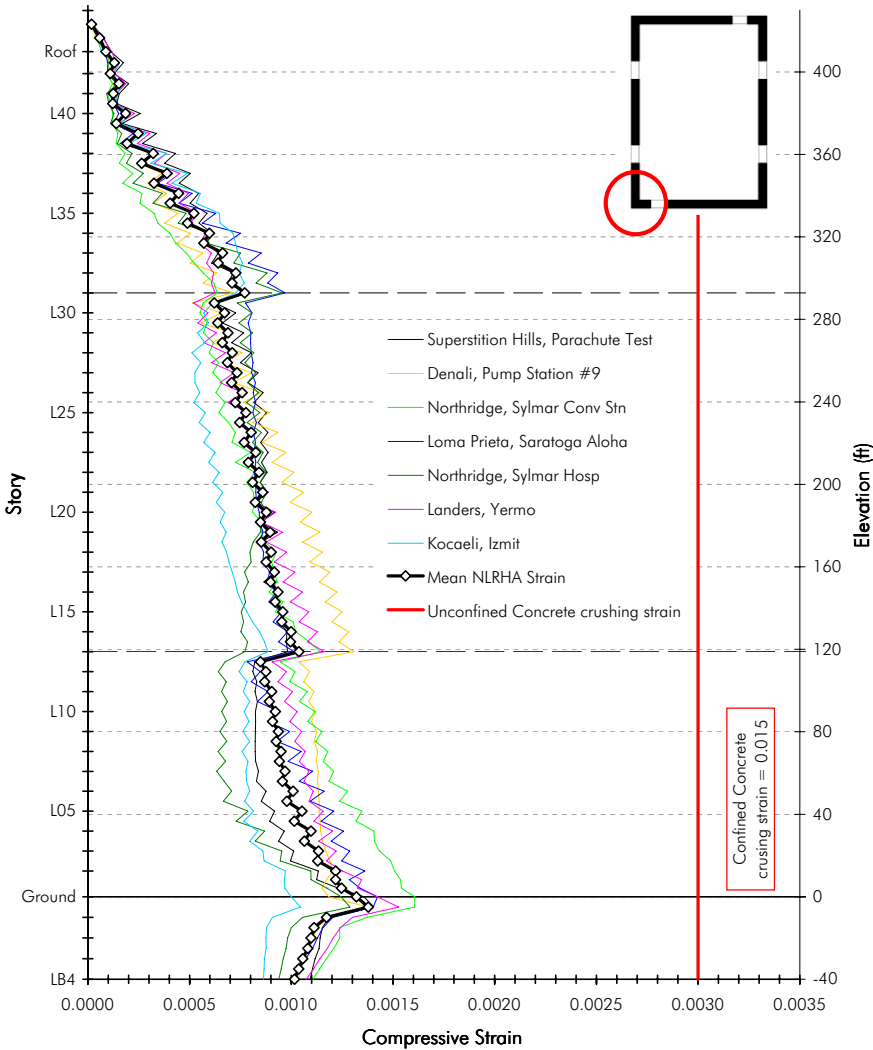

PEER TBI - Building 1B - Core Only Building for CSSC

Core Wall Compression Strains SE Corner

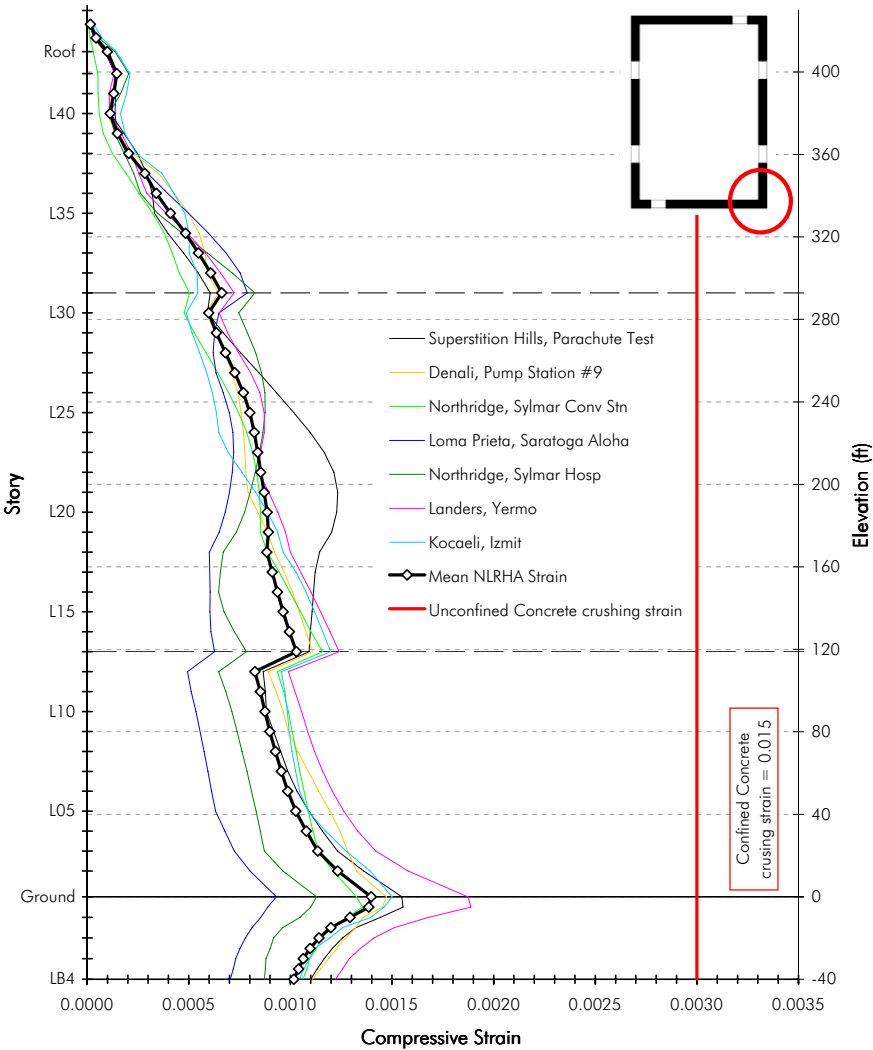

PEER TBI - Building 1B - Core Only Building for CSSC

Building 1C

Core Wall Compression Strains SW Corner

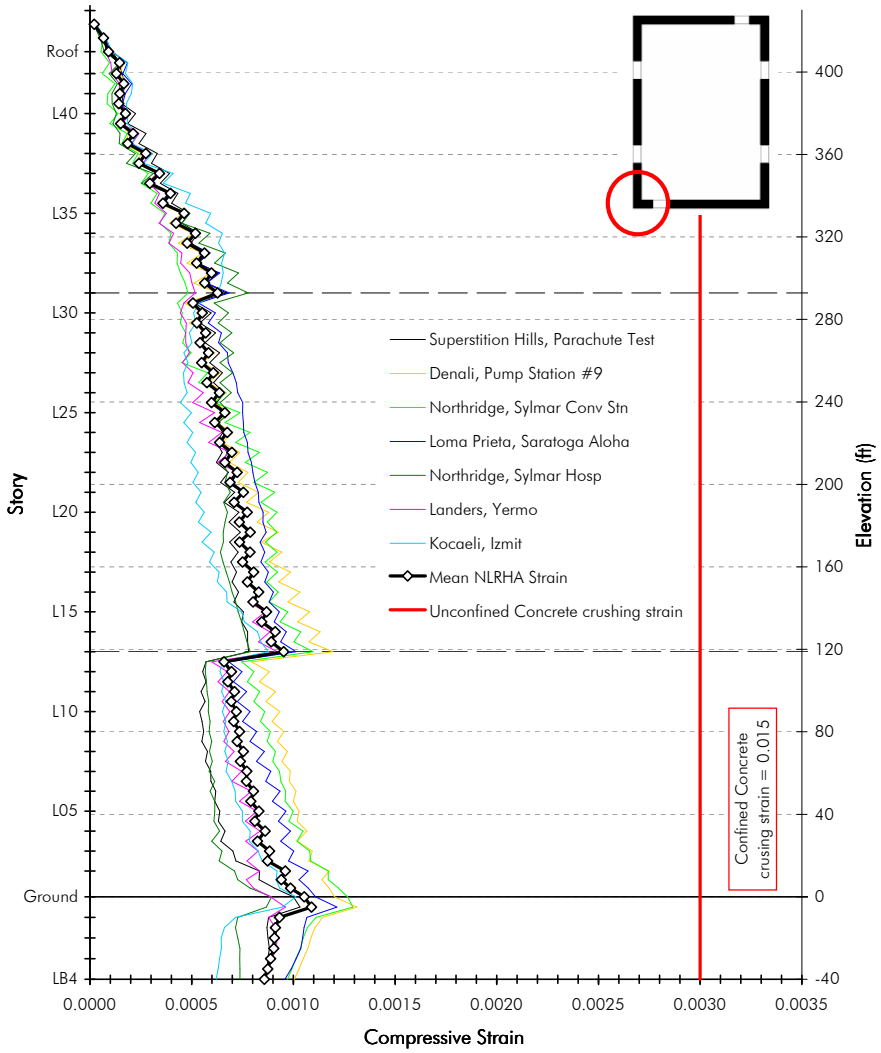

PEER TBI - Building 1C - Core Only Building for CSSC

Core Wall Compression Strains SE Corner

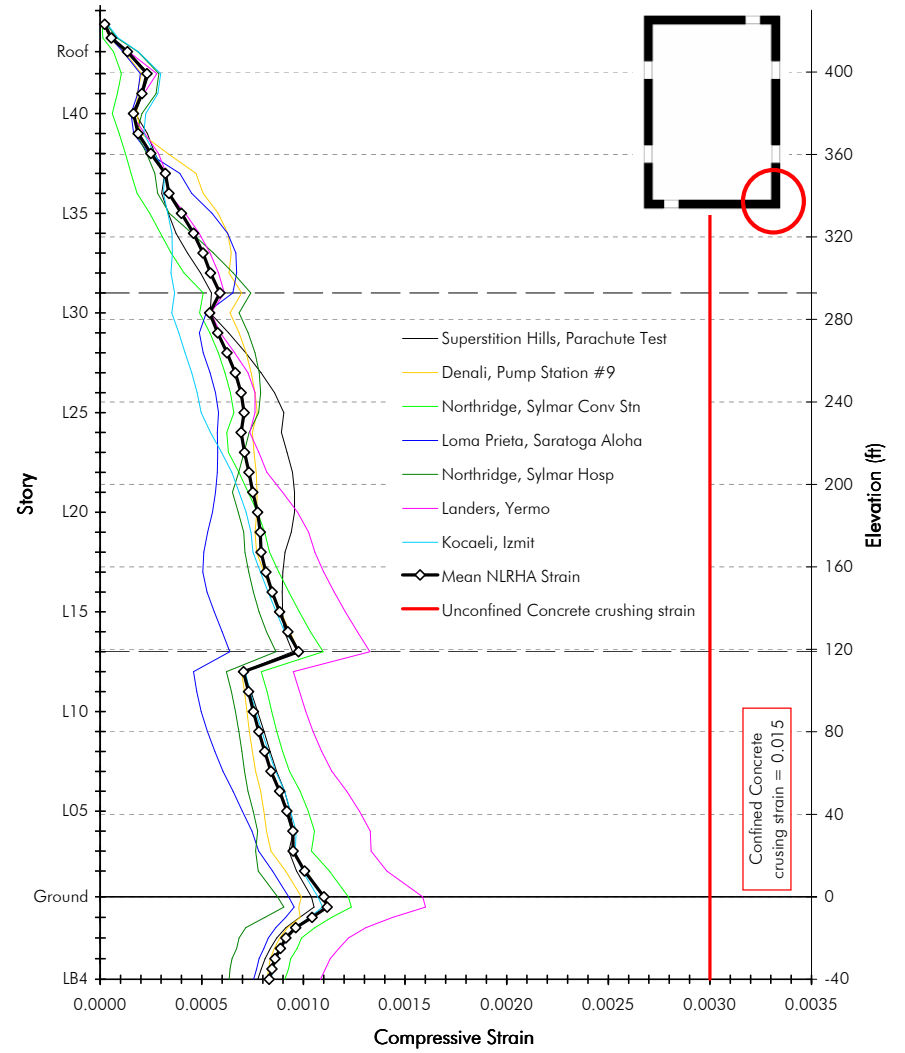

PEER TBI - Building 1C - Core Only Building for CSSC

Building 1B

Core Wall Compression Strains NW Corner

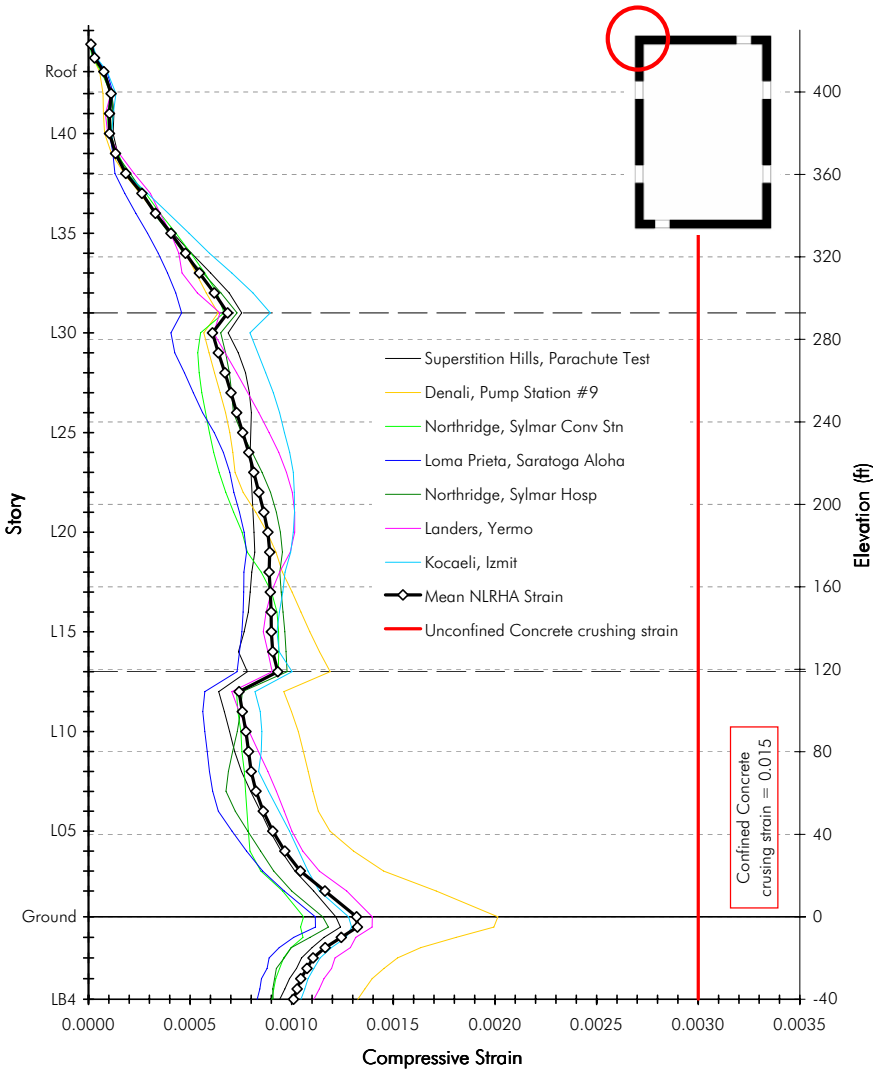

PEER TBI - Building 1B - Core Only Building for CSSC

Core Wall Compression Strains NE Corner

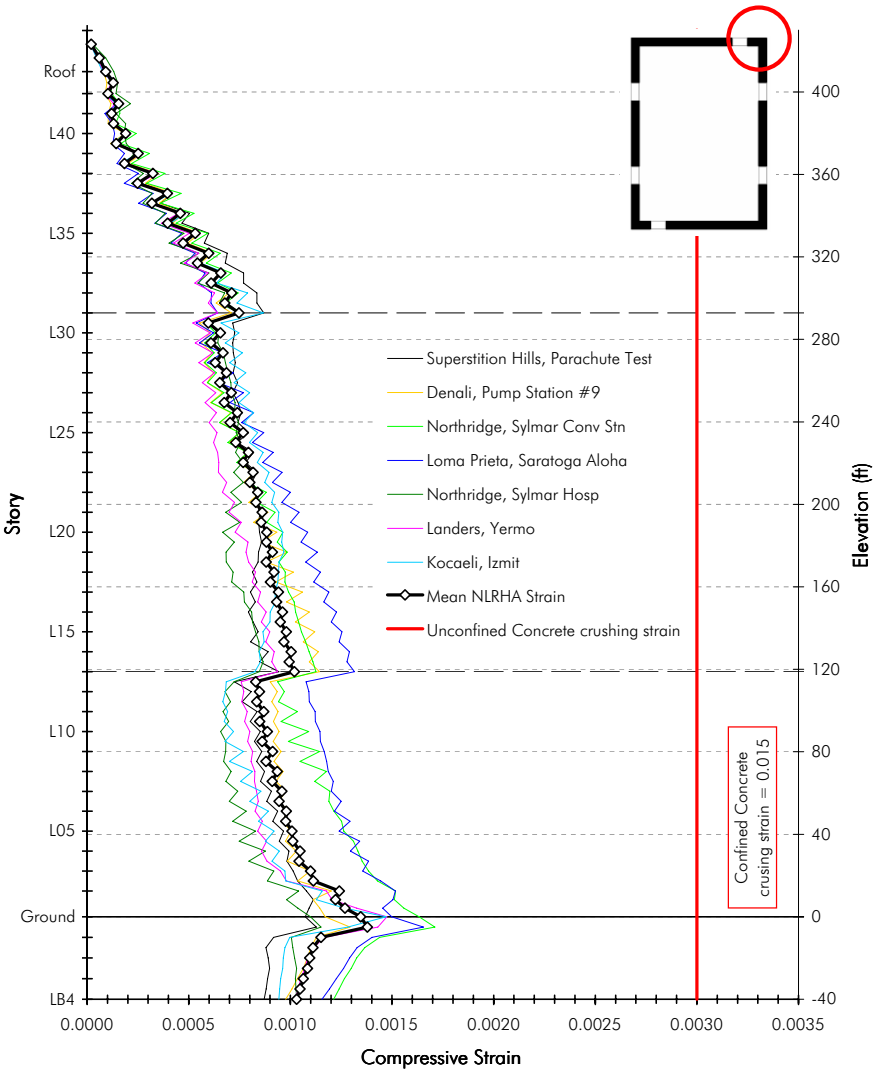

PEER TBI - Building 1B - Core Only Building for CSSC

Building 1C

Core Wall Compression Strains NW Corner

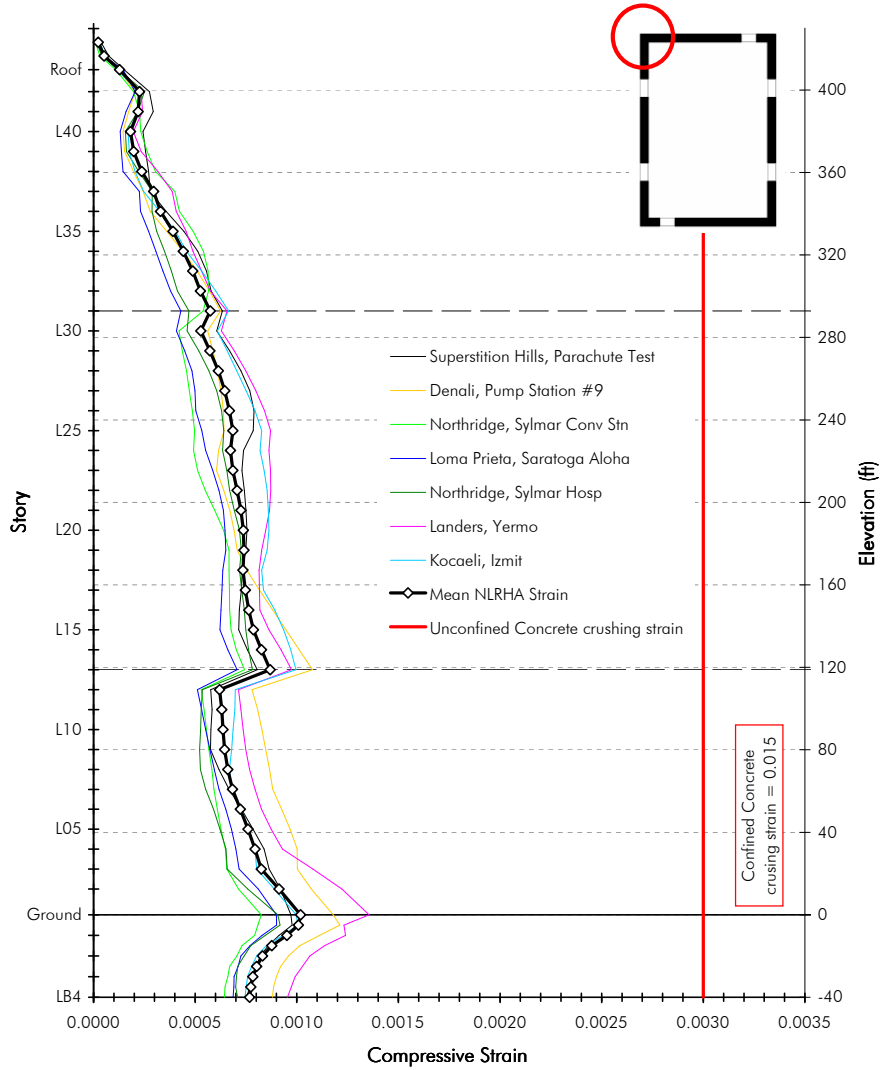

PEER TBI - Building 1C - Core Only Building for CSSC

Core Wall Compression Strains NE Corner

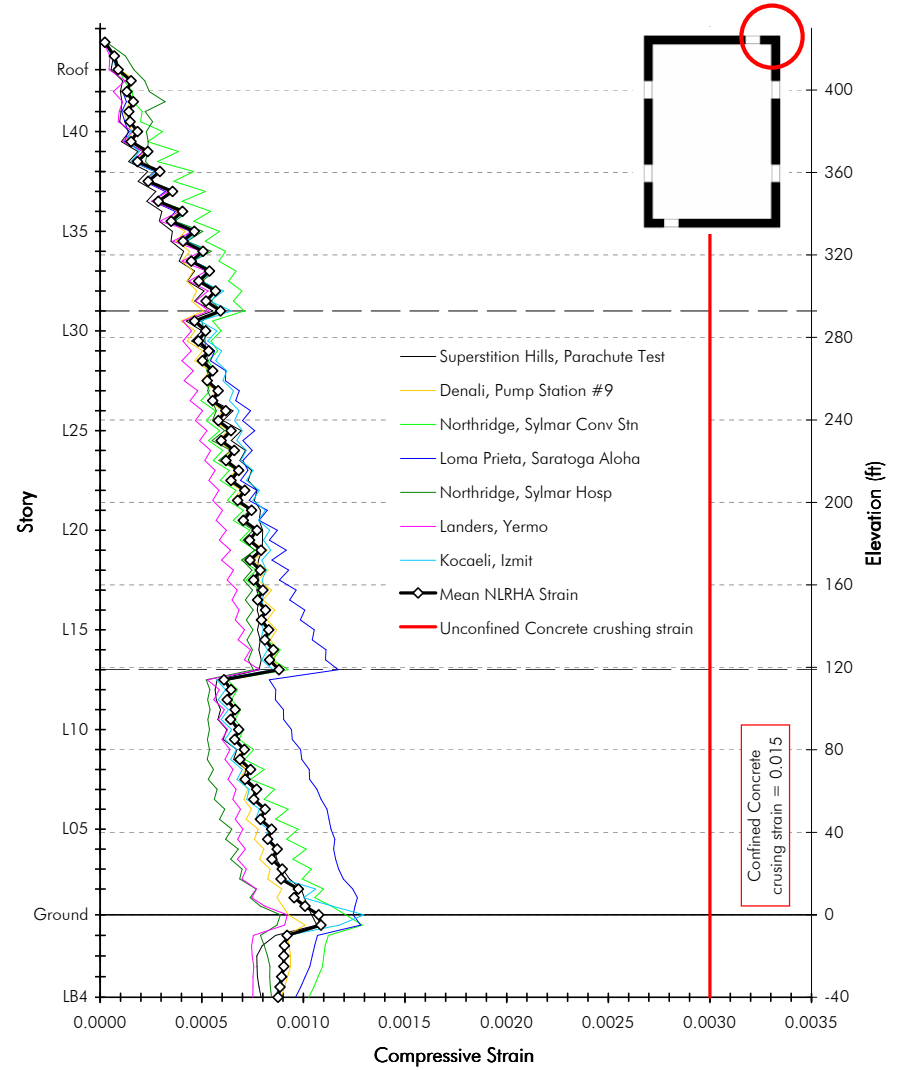

PEER TBI - Building 1C - Core Only Building for CSSC

Building 1B

Core Wall Tensile Strains SW Corner

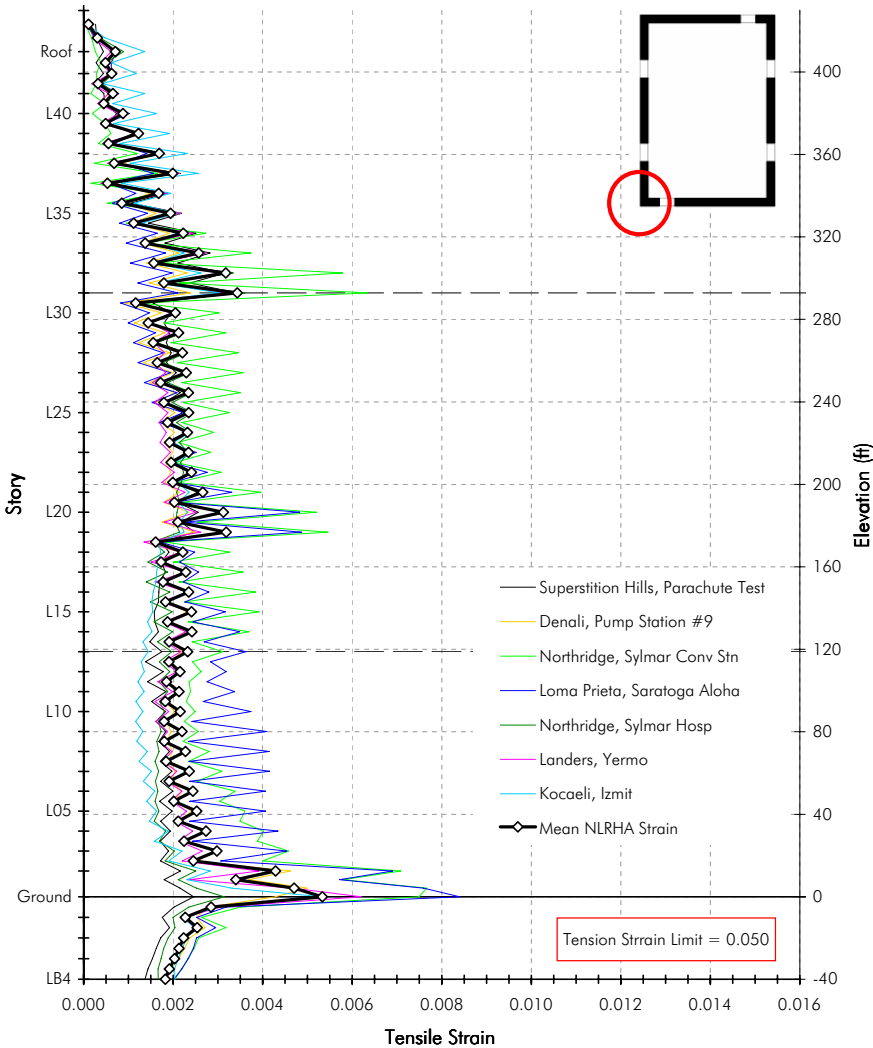

PEER TBI - Building 1B - Core Only Building for CSSC

Core Wall Tensile Strains SE Corner

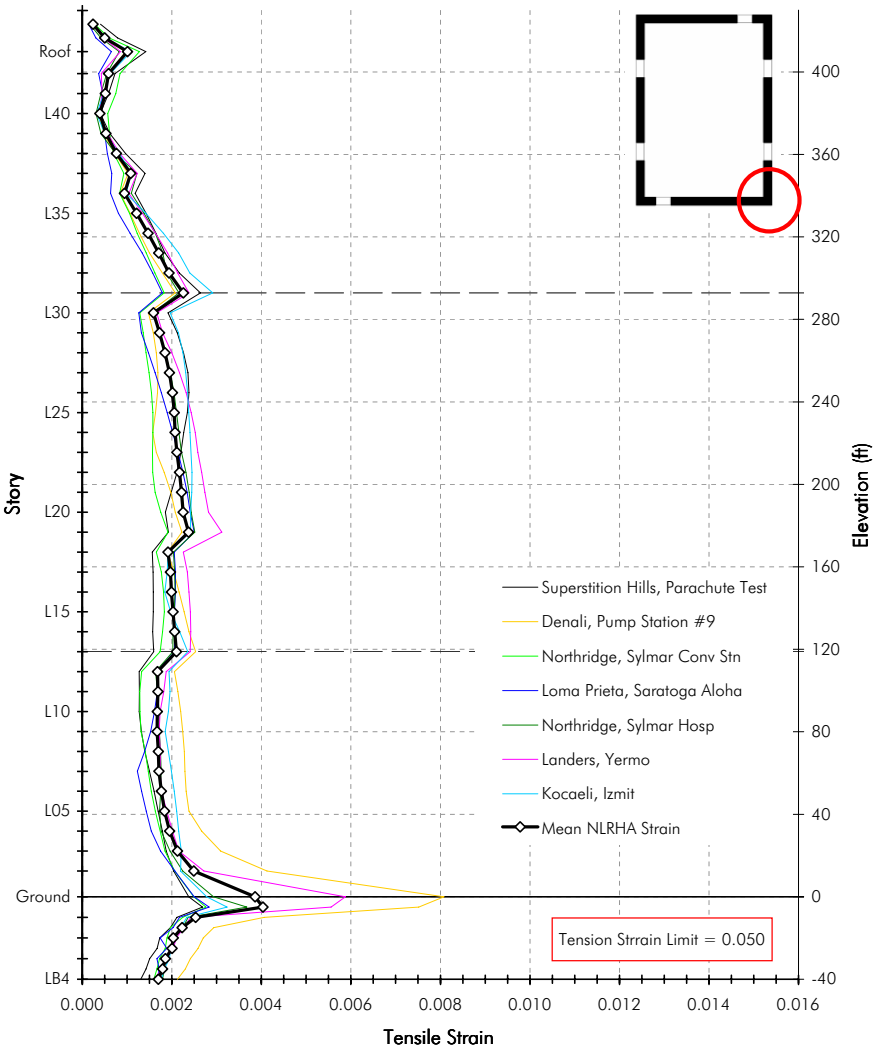

PEER TBI - Building 1B - Core Only Building for CSSC

Building 1C

Core Wall Tensile Strains SW Corner

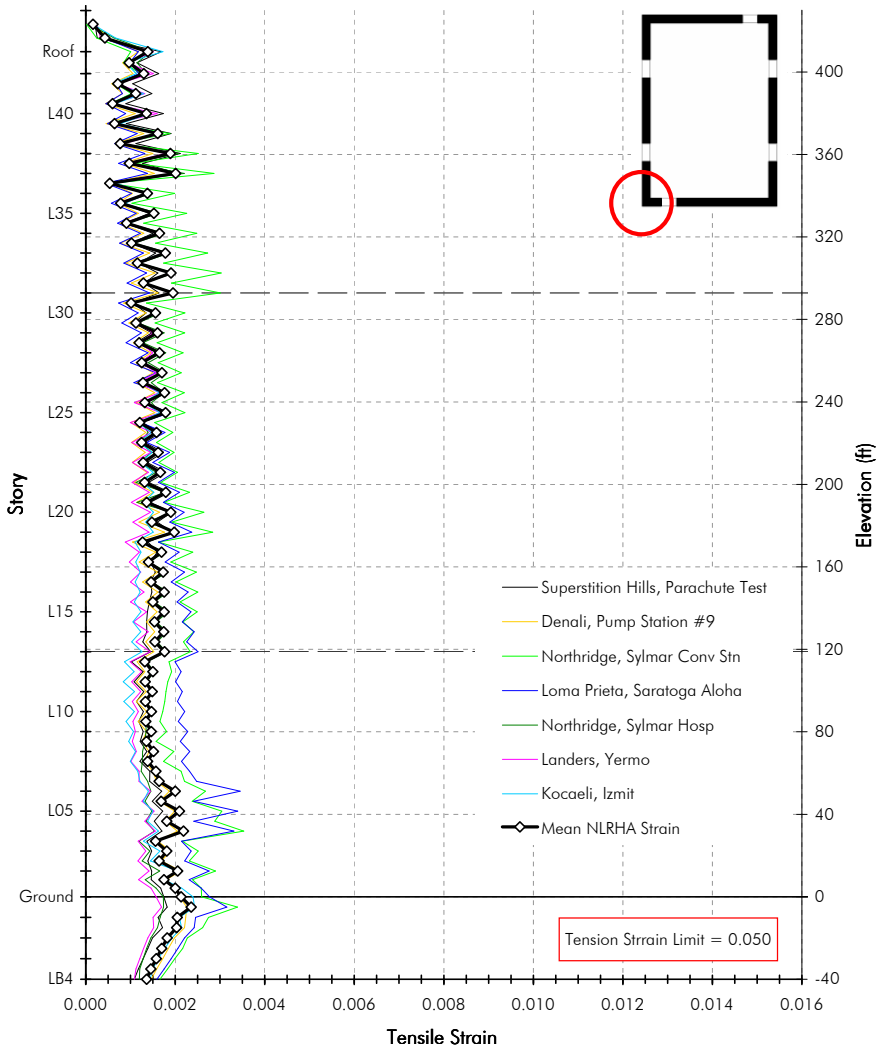

PEER TBI - Building 1C - Core Only Building for CSSC

Core Wall Tensile Strains SE Corner

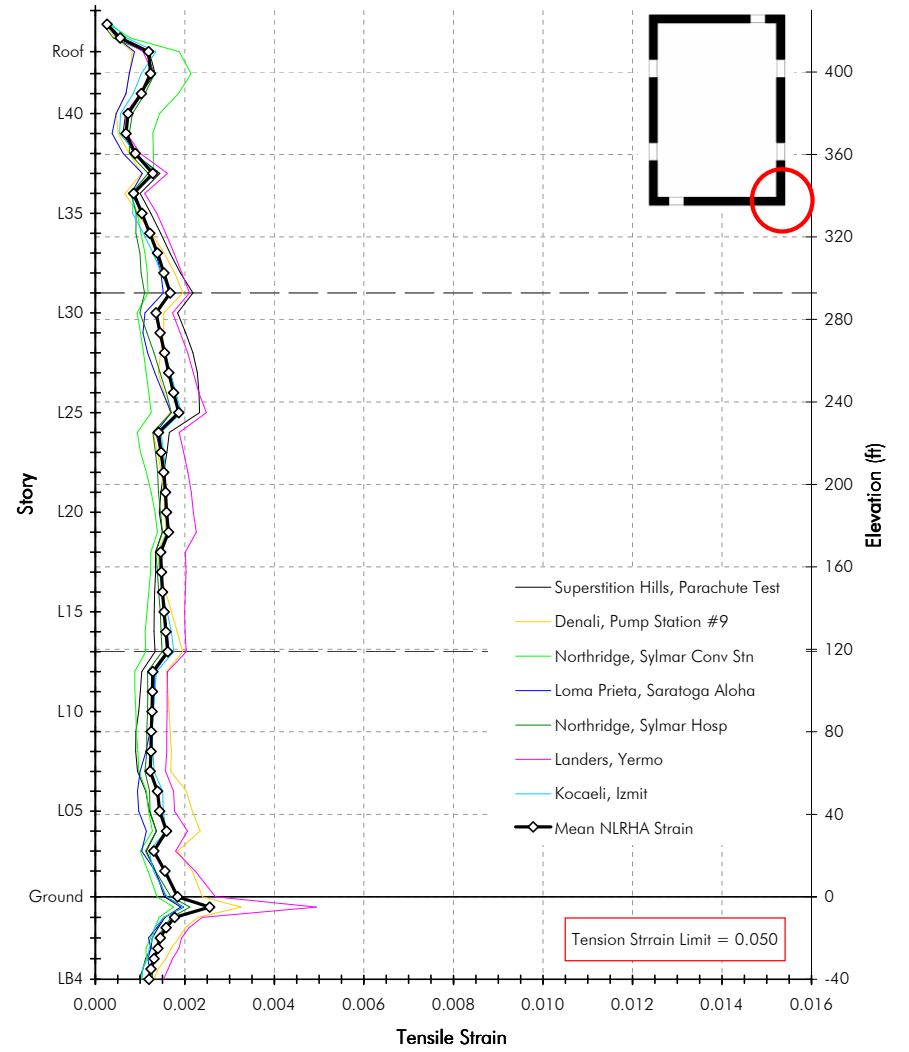

PEER TBI - Building 1C - Core Only Building for CSSC

Building 1B

Core Wall Tensile Strains NW Corner

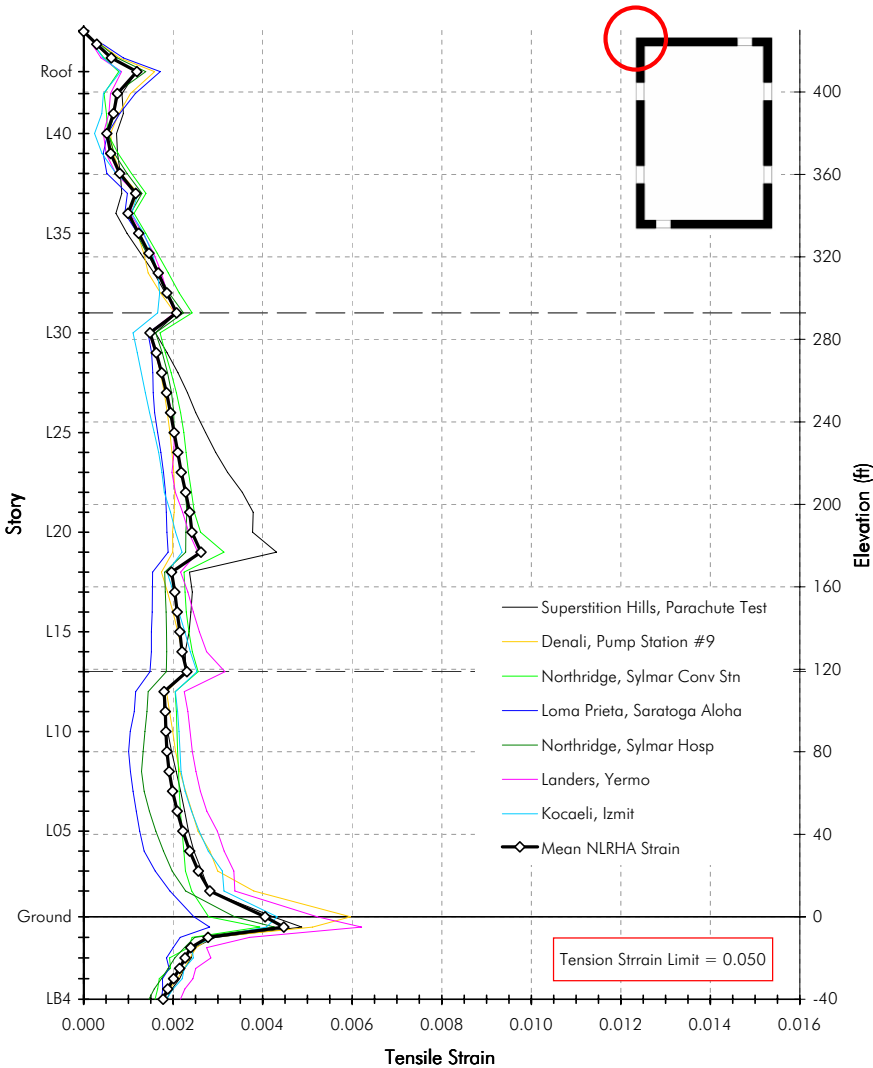

PEER TBI - Building 1B - Core Only Building for CSSC

Core Wall Tensile Strains NE Corner

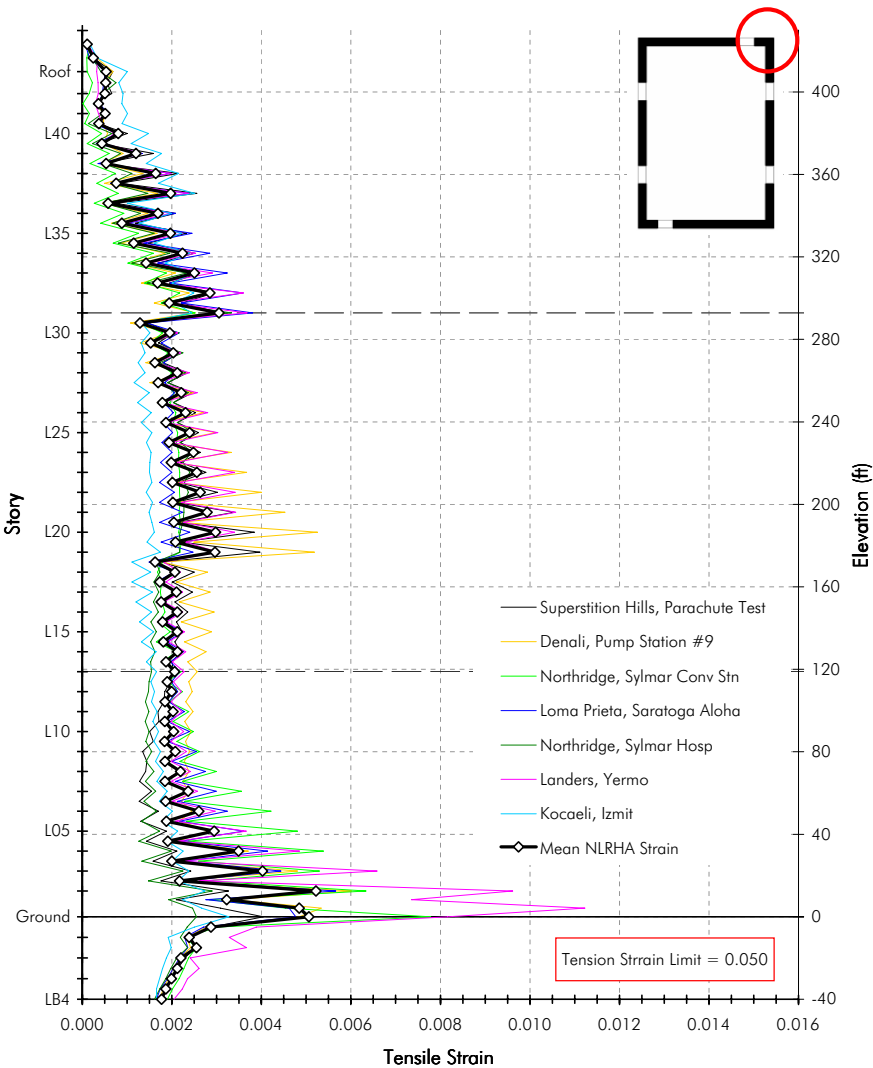

PEER TBI - Building 1B - Core Only Building for CSSC

Building 1C

Core Wall Tensile Strains NW Corner

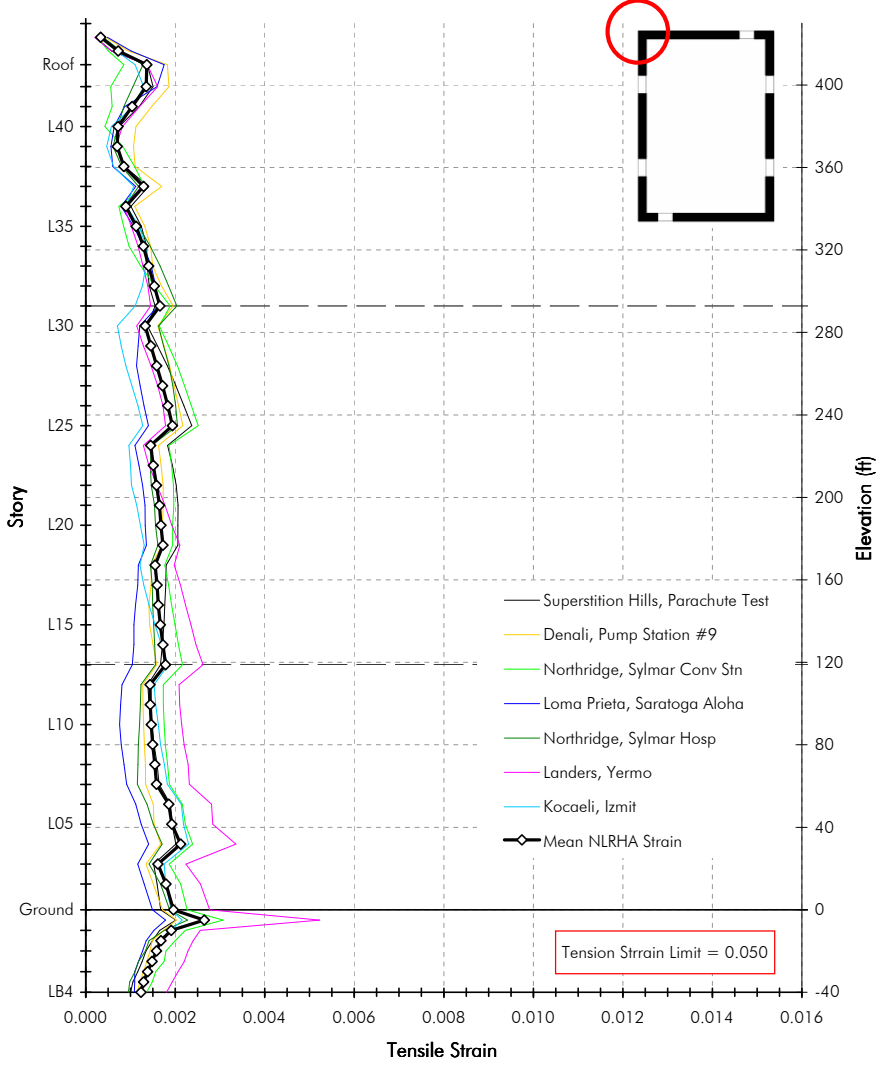

PEER TBI - Building 1C - Core Only Building for CSSC

Core Wall Tensile Strains NE Corner

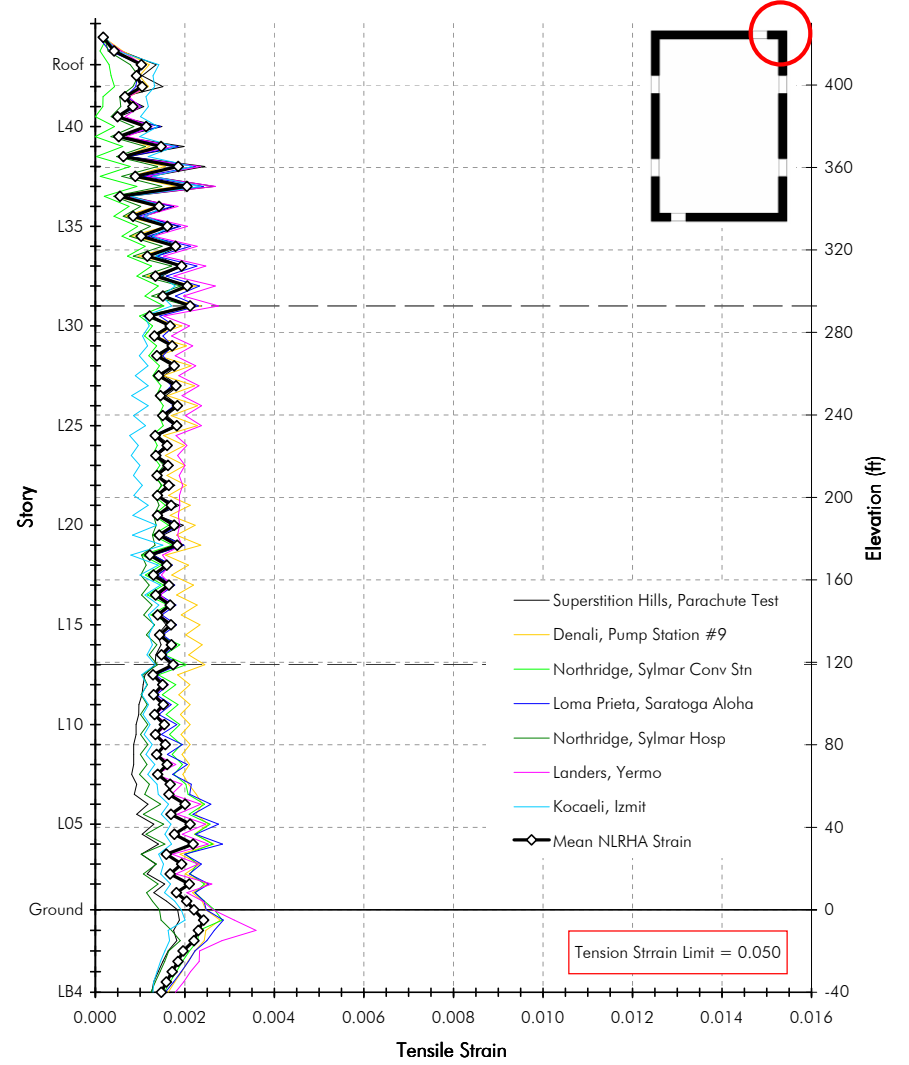

PEER TBI - Building 1C - Core Only Building for CSSC

APPENDIX 7
WALL PANEL SHEAR - MCE LEVEL
(BUILDINGS 1B AND 1C)



MAGNUSSON
KLEMENCIC
ASSOCIATES



Building 1B

Core Wall Shear Pier 01

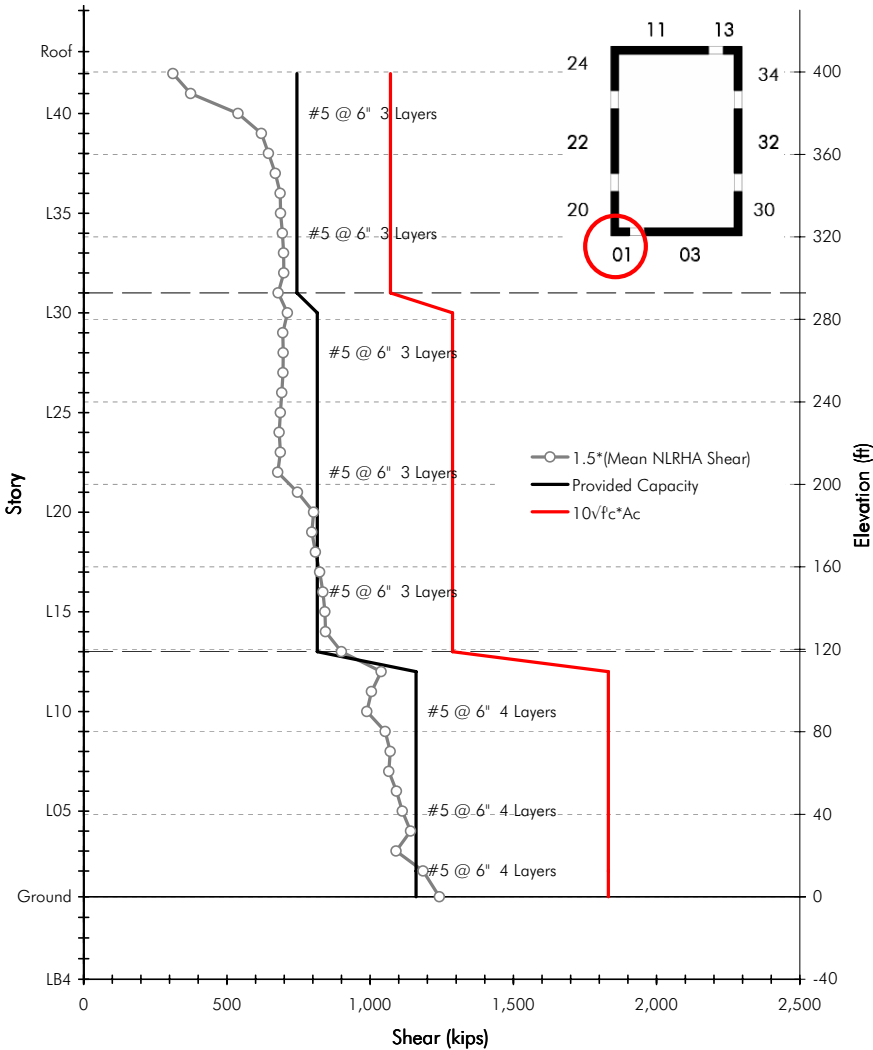

PEER TBI - Building 1B - Core Only Building for CSSC

Core Wall Shear Pier 13

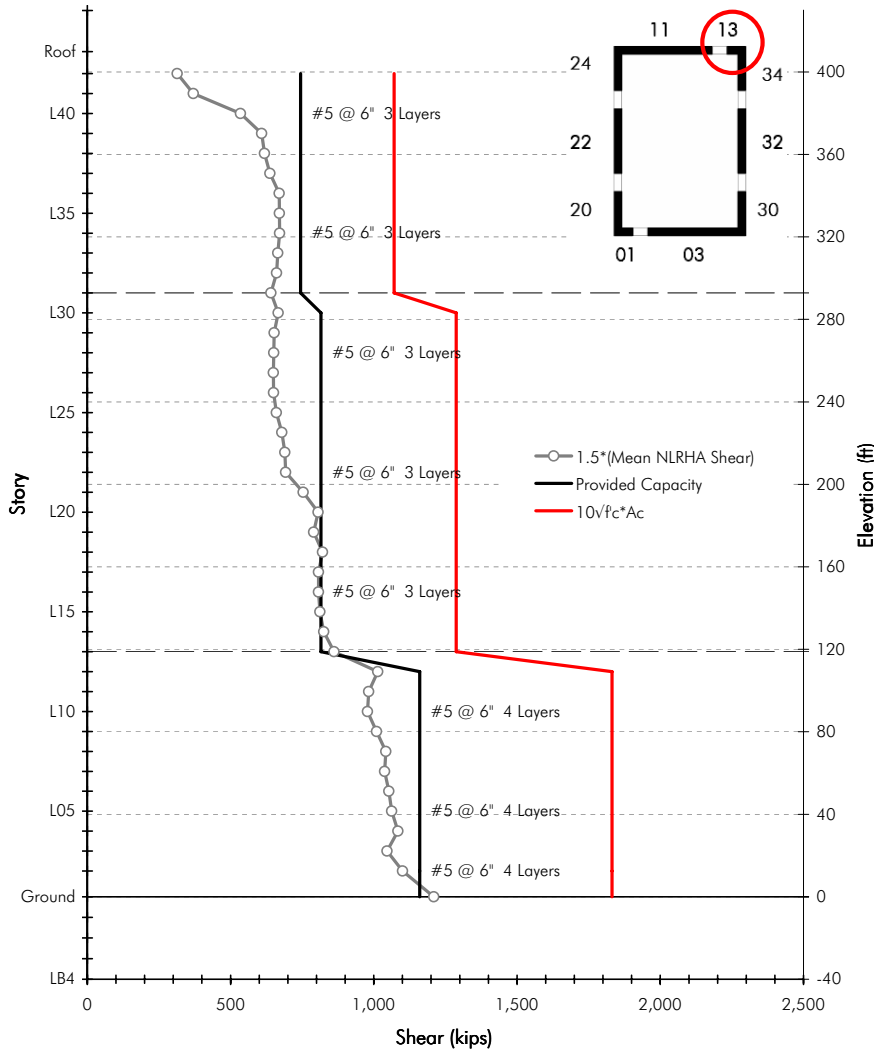

PEER TBI - Building 1B - Core Only Building for CSSC

Building 1C

Core Wall Shear Pier 01

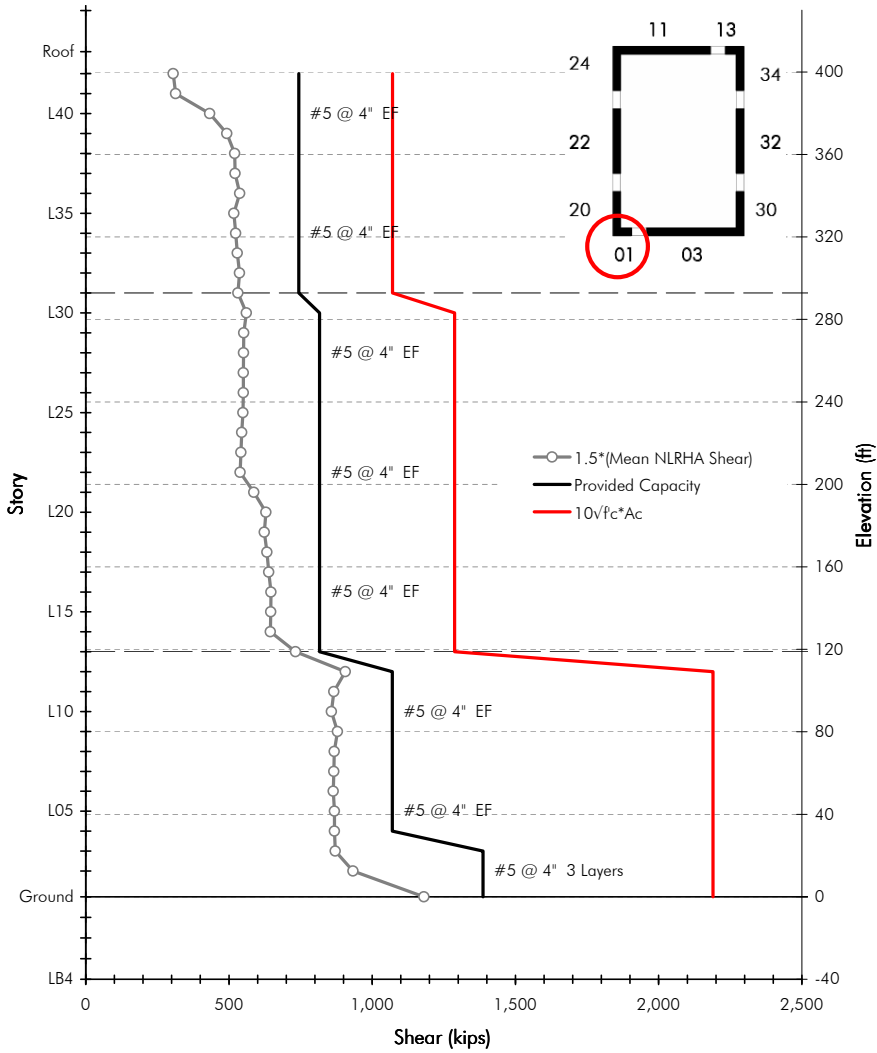

PEER TBI - Building 1C - Core Only Building for CSSC

Core Wall Shear Pier 13

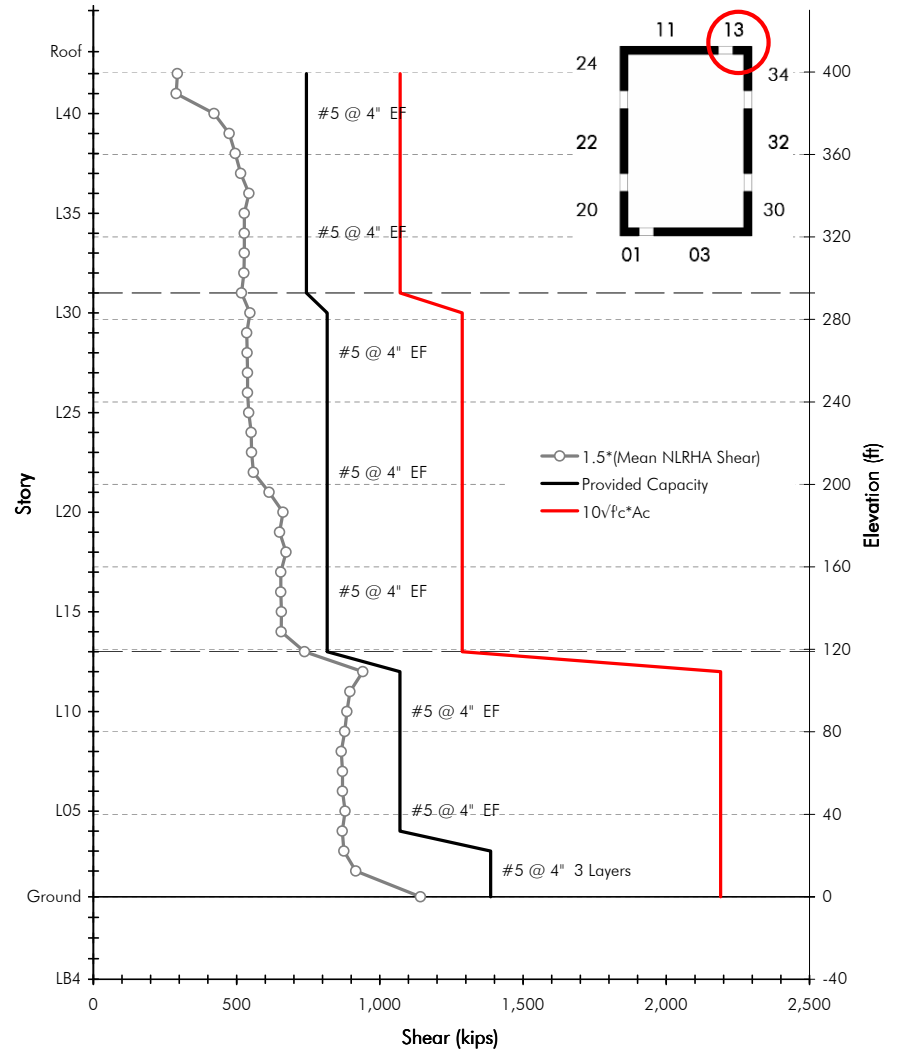

PEER TBI - Building 1C - Core Only Building for CSSC

Building 1B

Core Wall Shear Pier 03

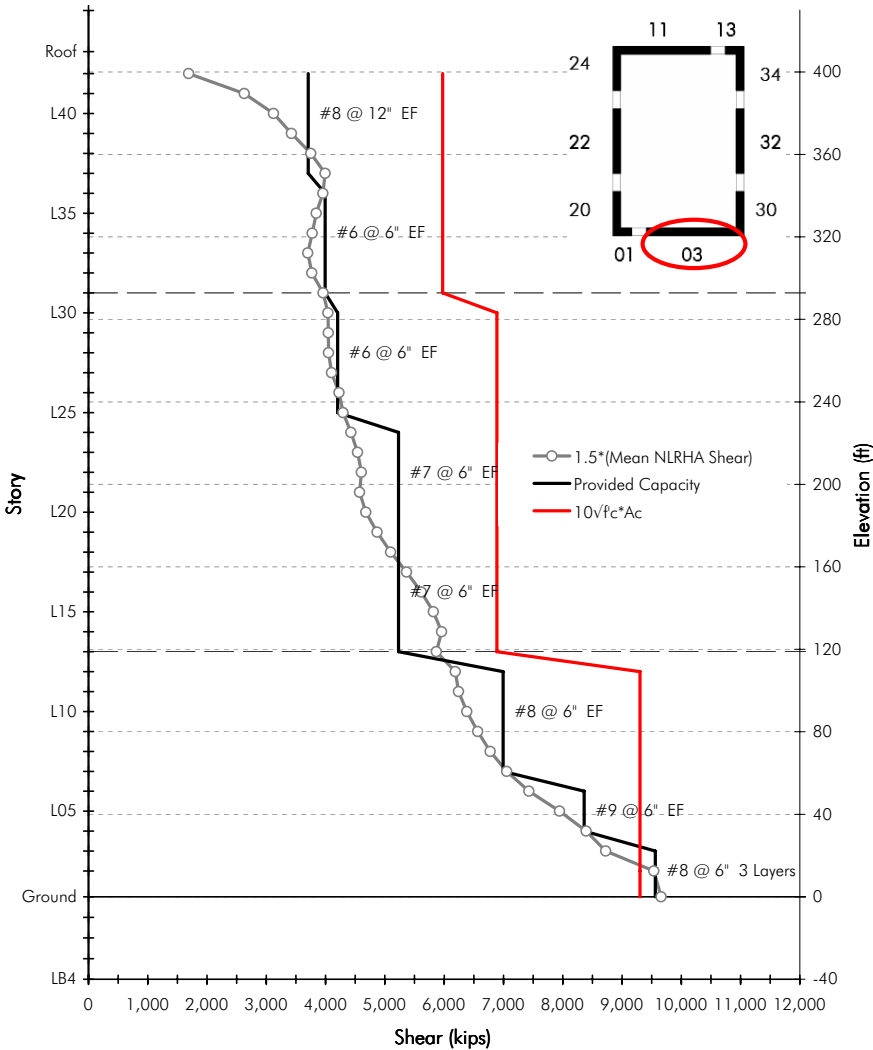

PEER TBI - Building 1B - Core Only Building for CSSC

Core Wall Shear Pier 11

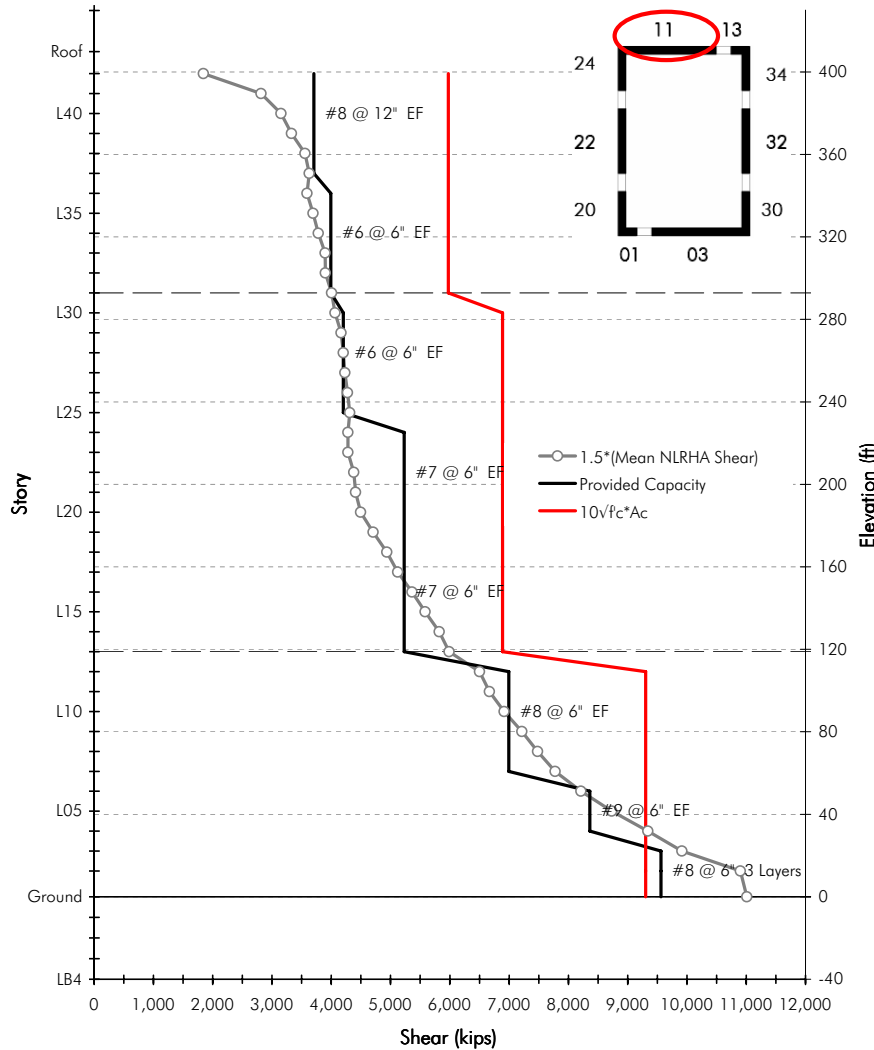

PEER TBI - Building 1B - Core Only Building for CSSC

Building 1C

Core Wall Shear Pier 03

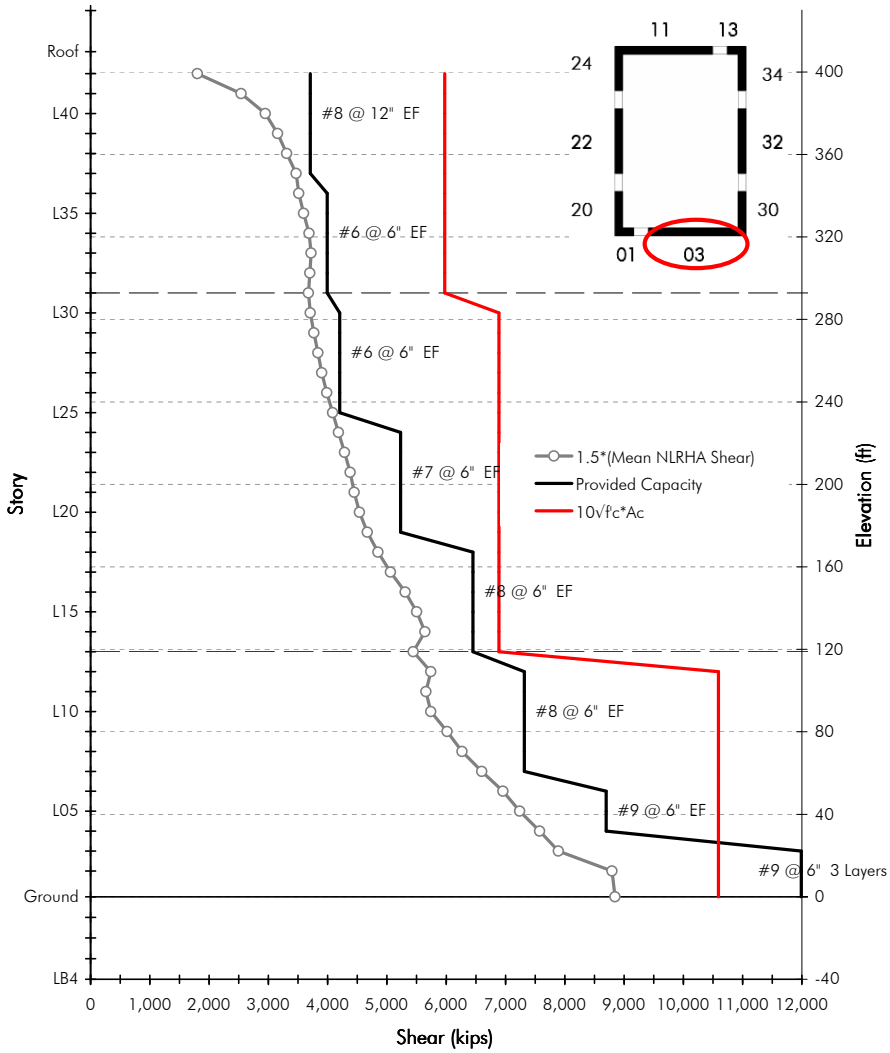

PEER TBI - Building 1C - Core Only Building for CSSC

Core Wall Shear Pier 11

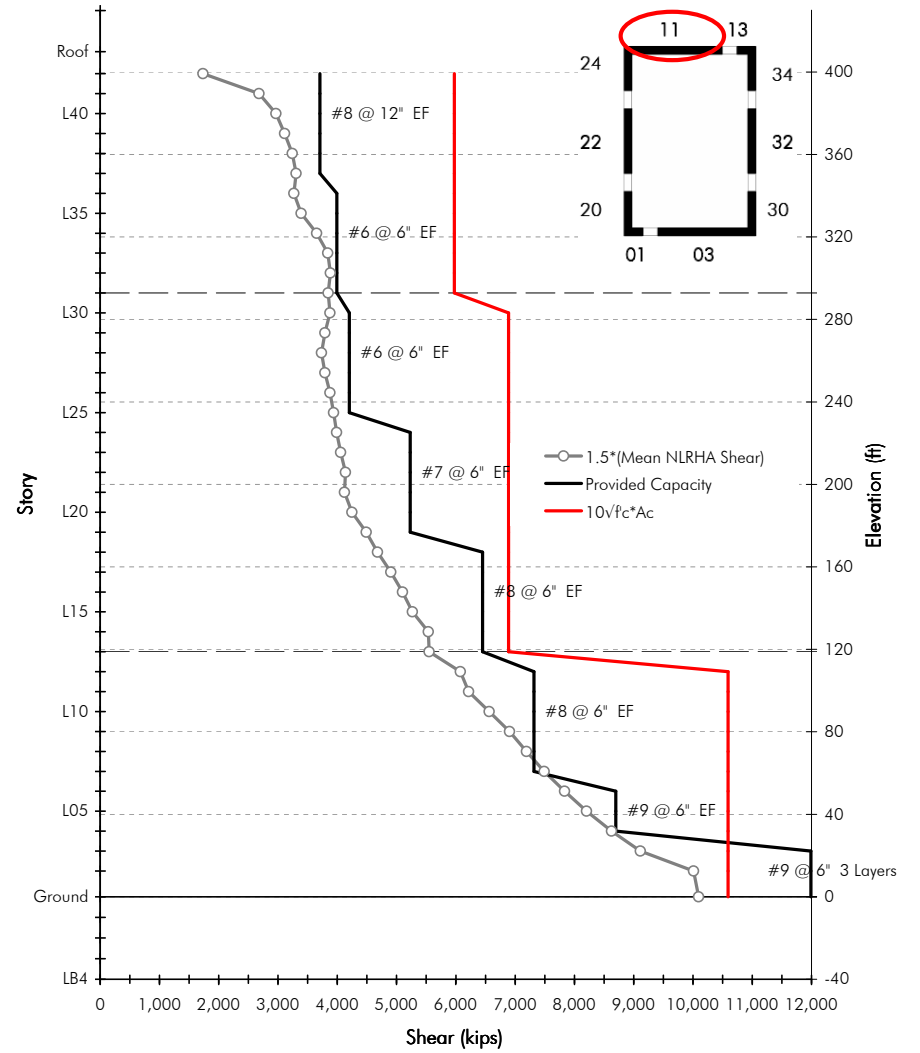

PEER TBI - Building 1C - Core Only Building for CSSC

Building 1B

Core Wall Shear Pier 20

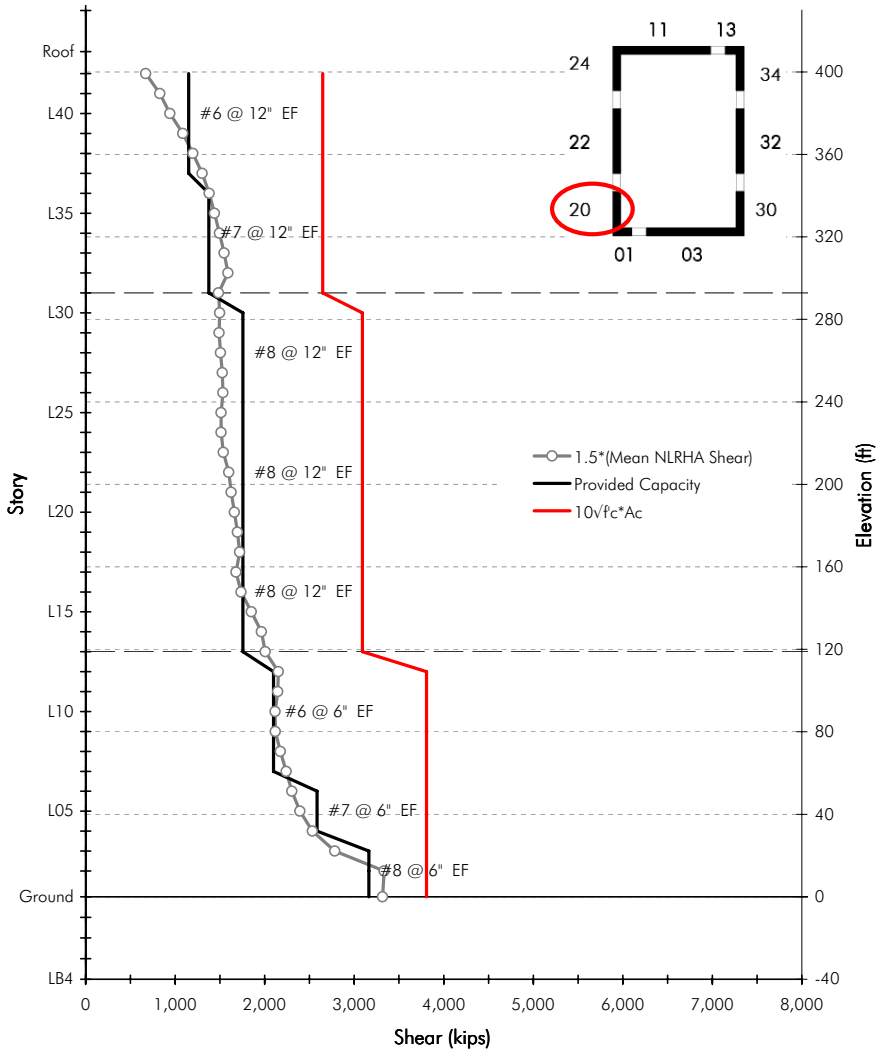

PEER TBI - Building 1B - Core Only Building for CSSC

Core Wall Shear Pier 34

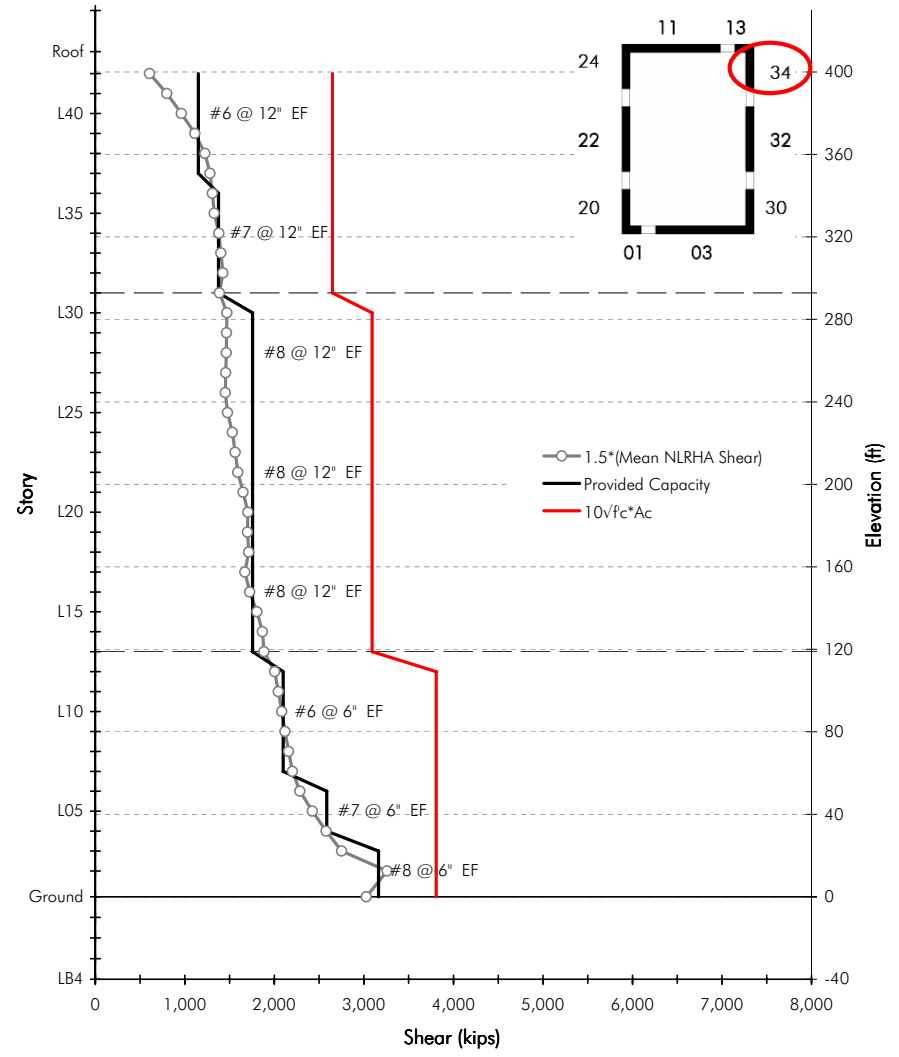

PEER TBI - Building 1B - Core Only Building for CSSC

Building 1C

Core Wall Shear Pier 20

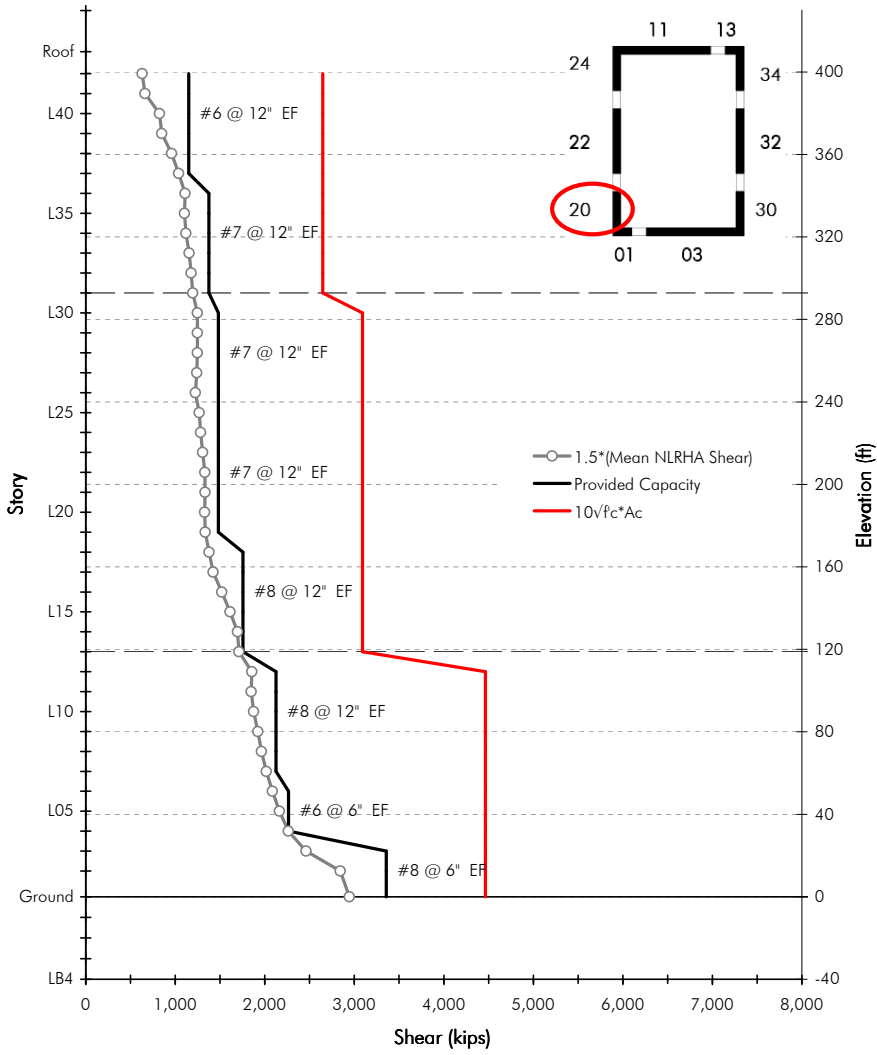

PEER TBI - Building 1C - Core Only Building for CSSC

Core Wall Shear Pier 34

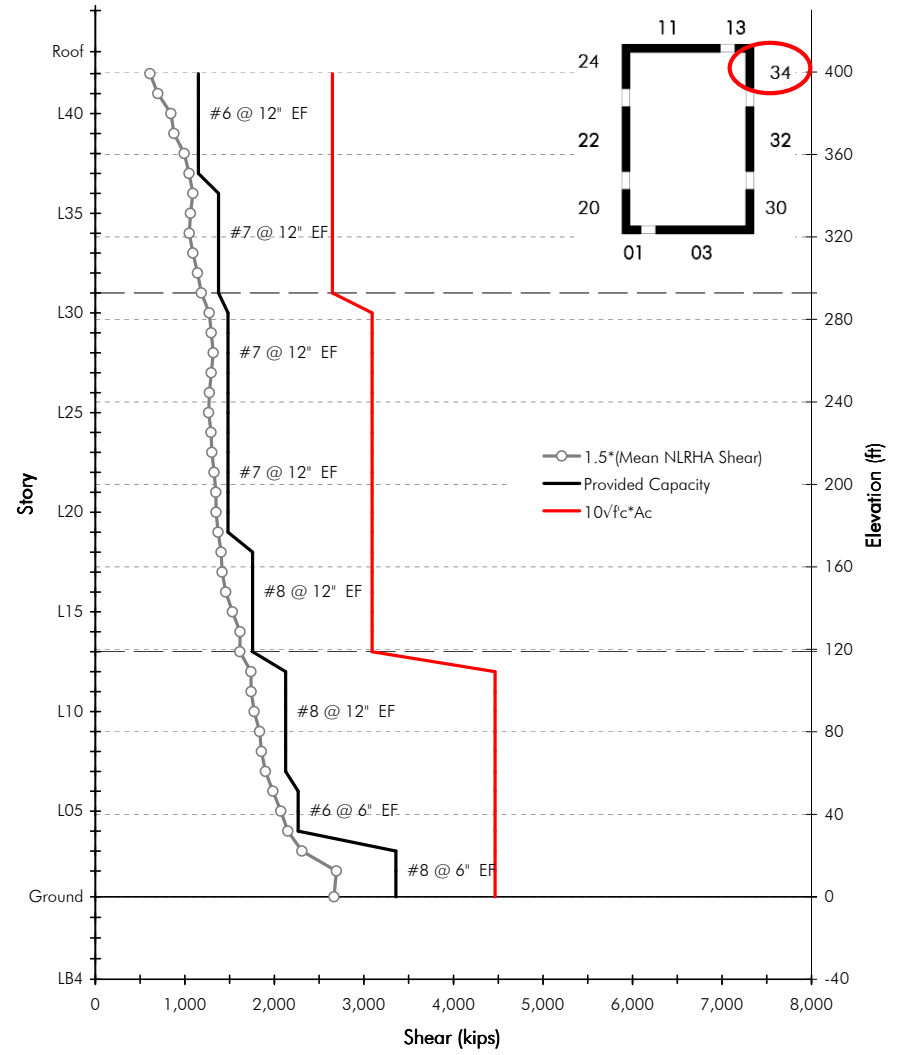

PEER TBI - Building 1C - Core Only Building for CSSC

Building 1B

Core Wall Shear Pier 22

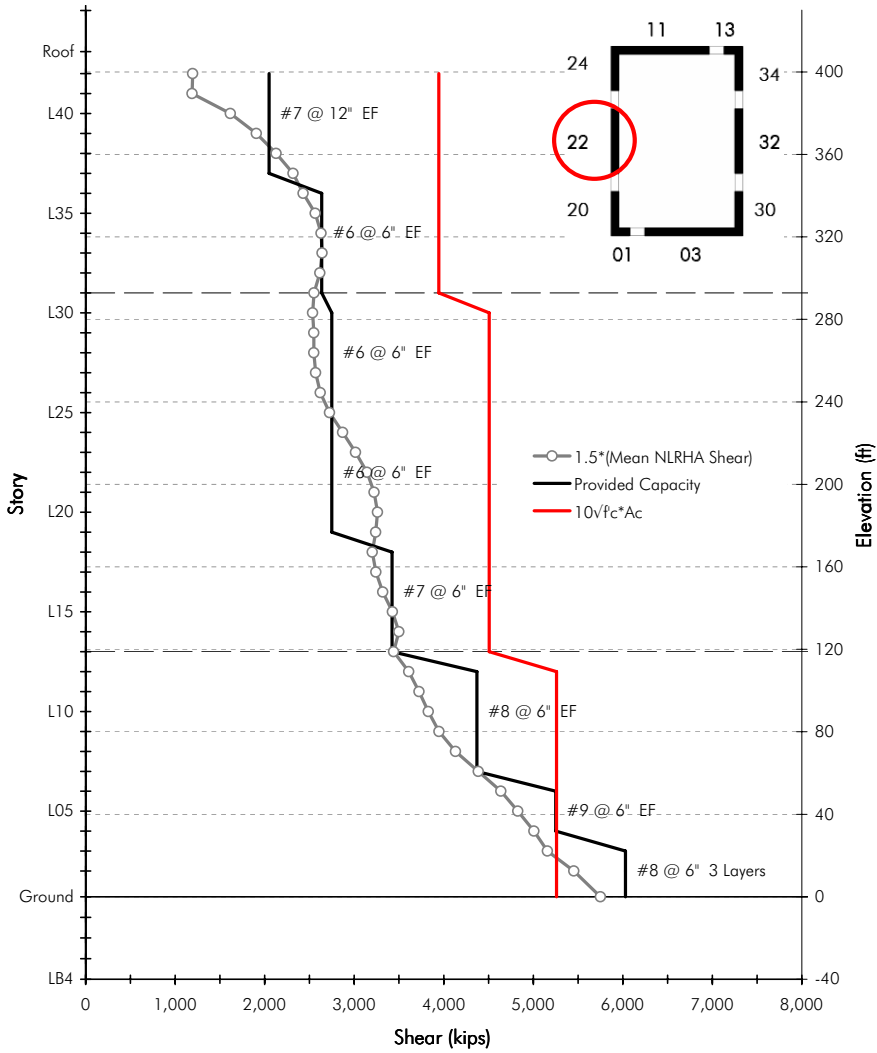

PEER TBI - Building 1B - Core Only Building for CSSC

Core Wall Shear Pier 32

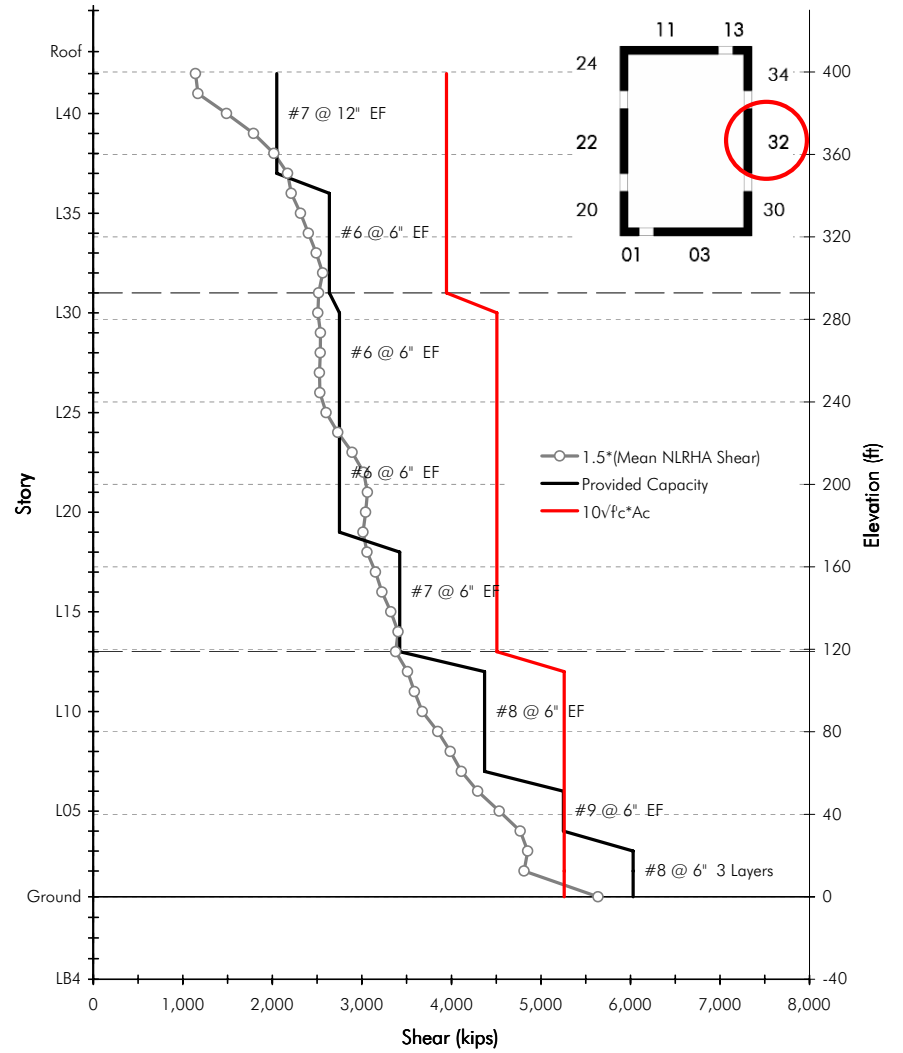

PEER TBI - Building 1B - Core Only Building for CSSC

Building 1C

Core Wall Shear Pier 22

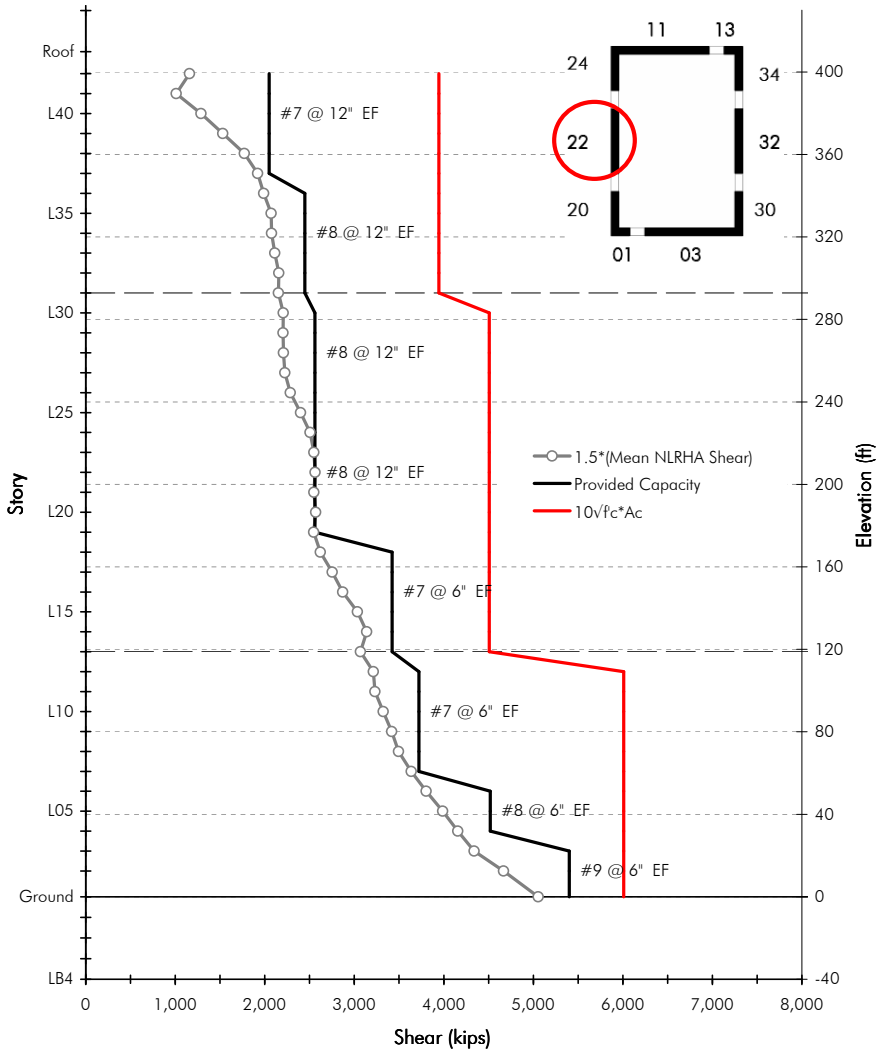

PEER TBI - Building 1C - Core Only Building for CSSC

Core Wall Shear Pier 32

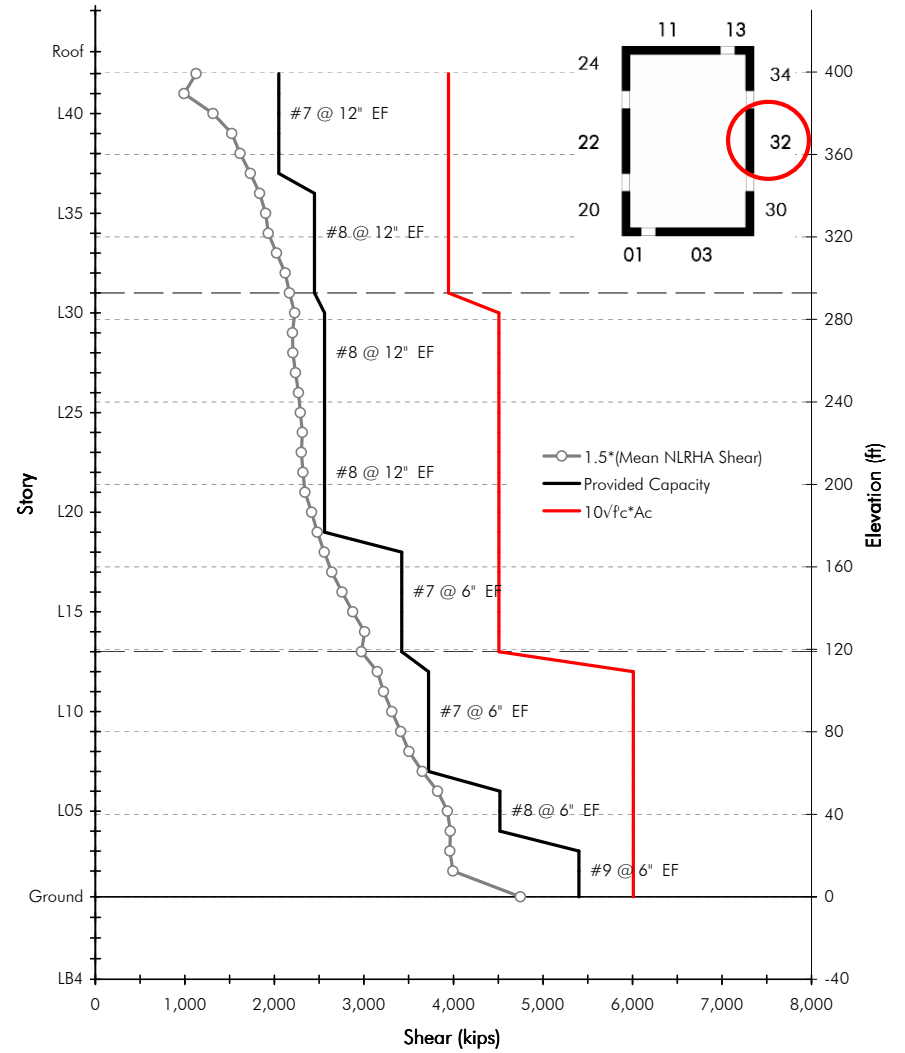

PEER TBI - Building 1C - Core Only Building for CSSC

Building 1B

Core Wall Shear Pier 24

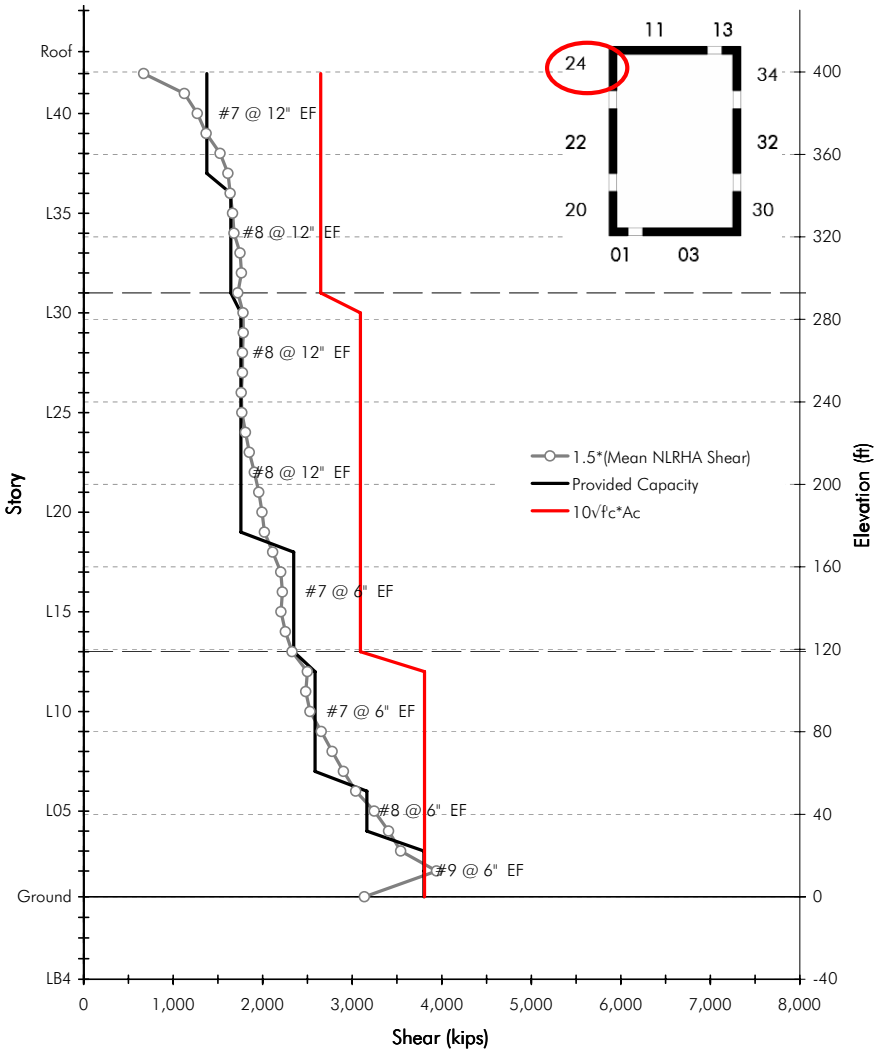

PEER TBI - Building 1B - Core Only Building for CSSC

Core Wall Shear Pier 30

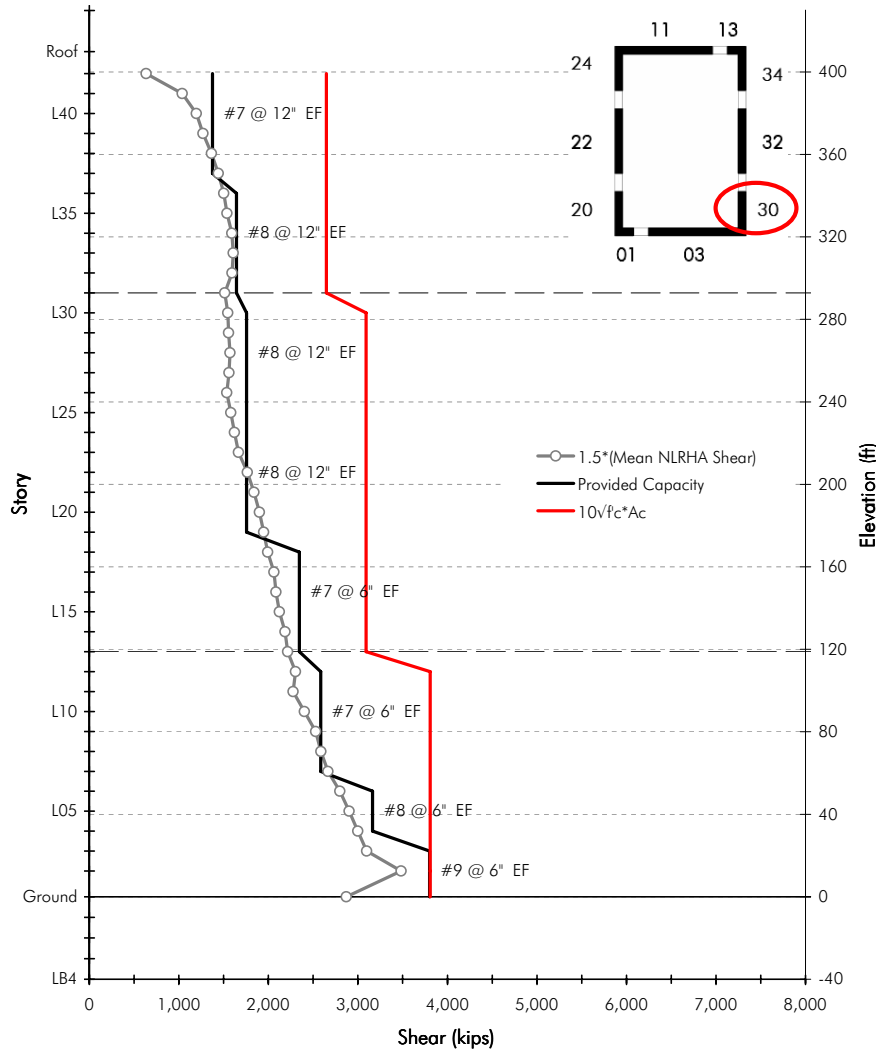

PEER TBI - Building 1B - Core Only Building for CSSC

Building 1C

Core Wall Shear Pier 24

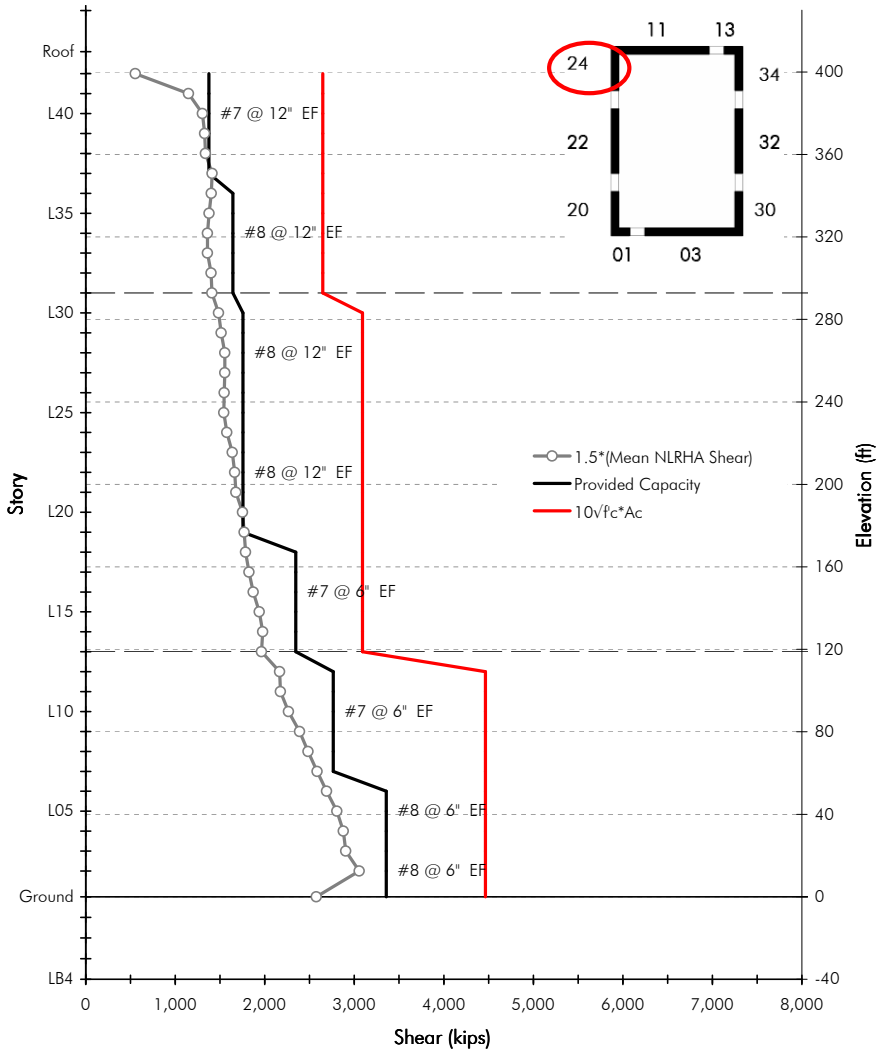

PEER TBI - Building 1C - Core Only Building for CSSC

Core Wall Shear Pier 30

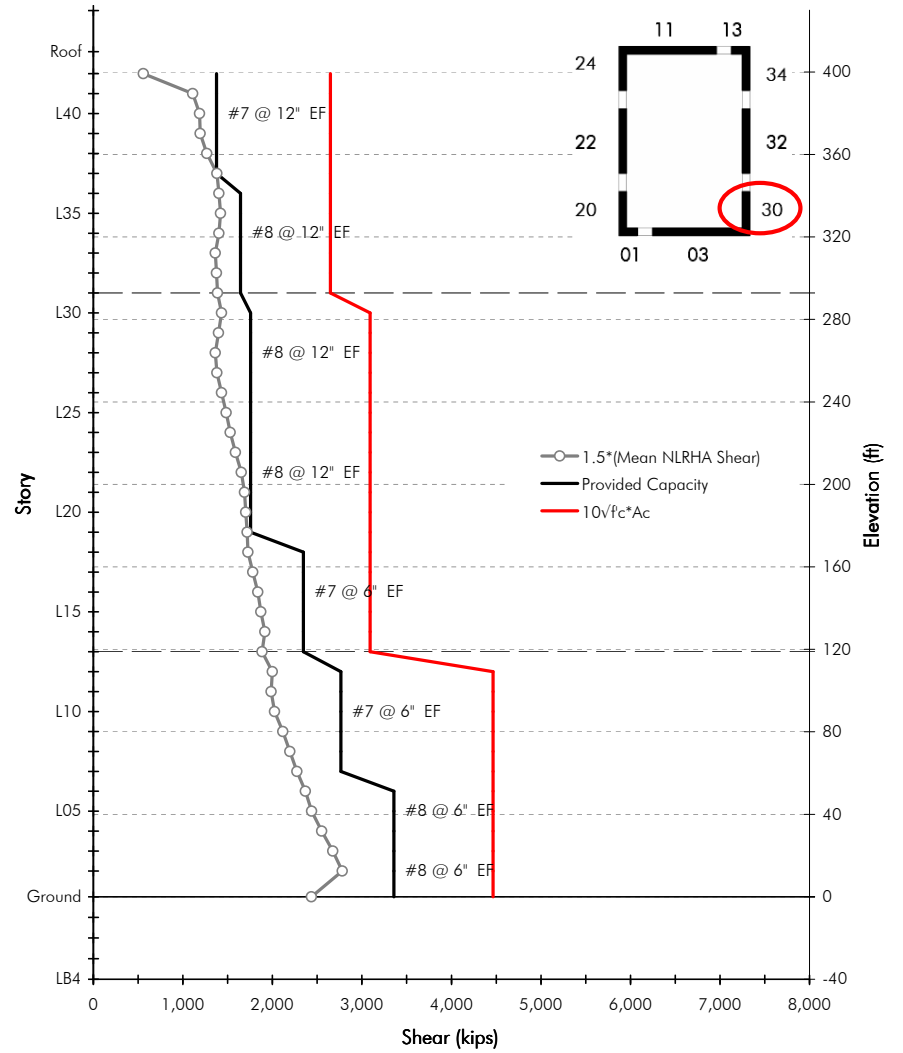

PEER TBI - Building 1C - Core Only Building for CSSC

Building 1B

Core Wall Shear Pier 01

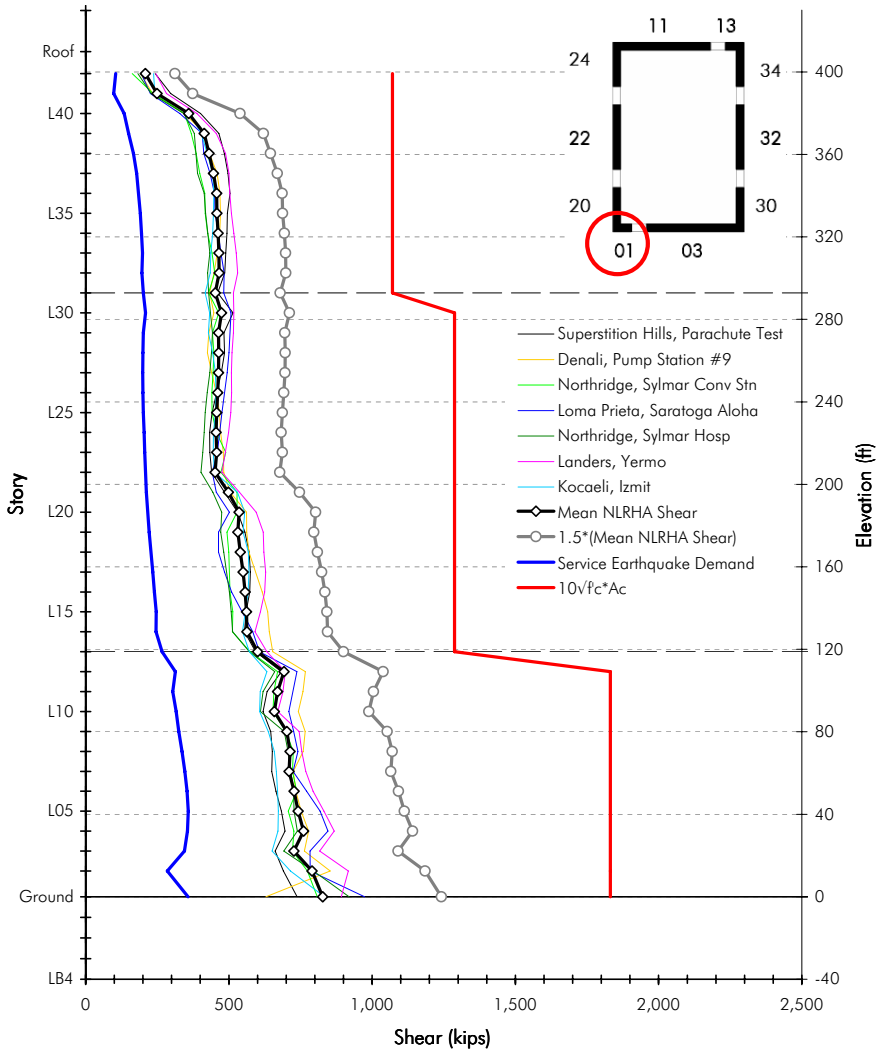

PEER TBI - Building 1B - Core Only Building for CSSC

Core Wall Shear Pier 13

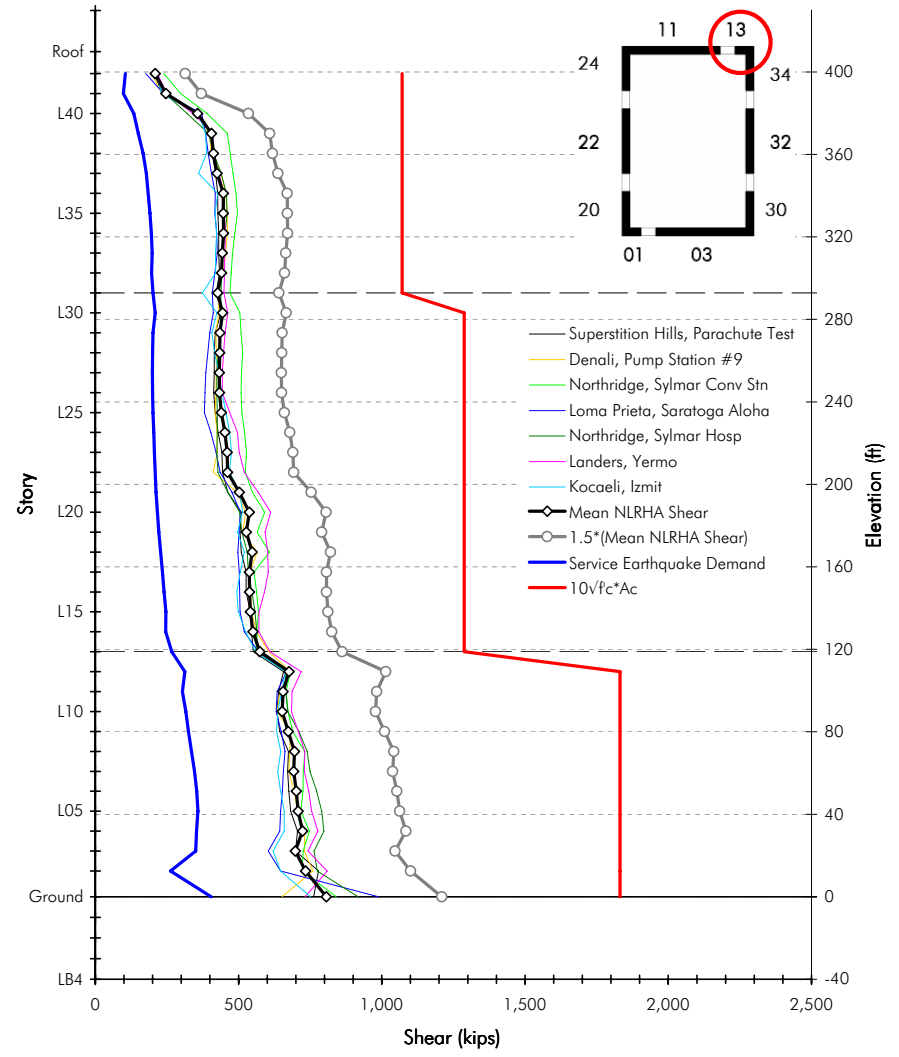

PEER TBI - Building 1B - Core Only Building for CSSC

Building 1C

Core Wall Shear Pier 01

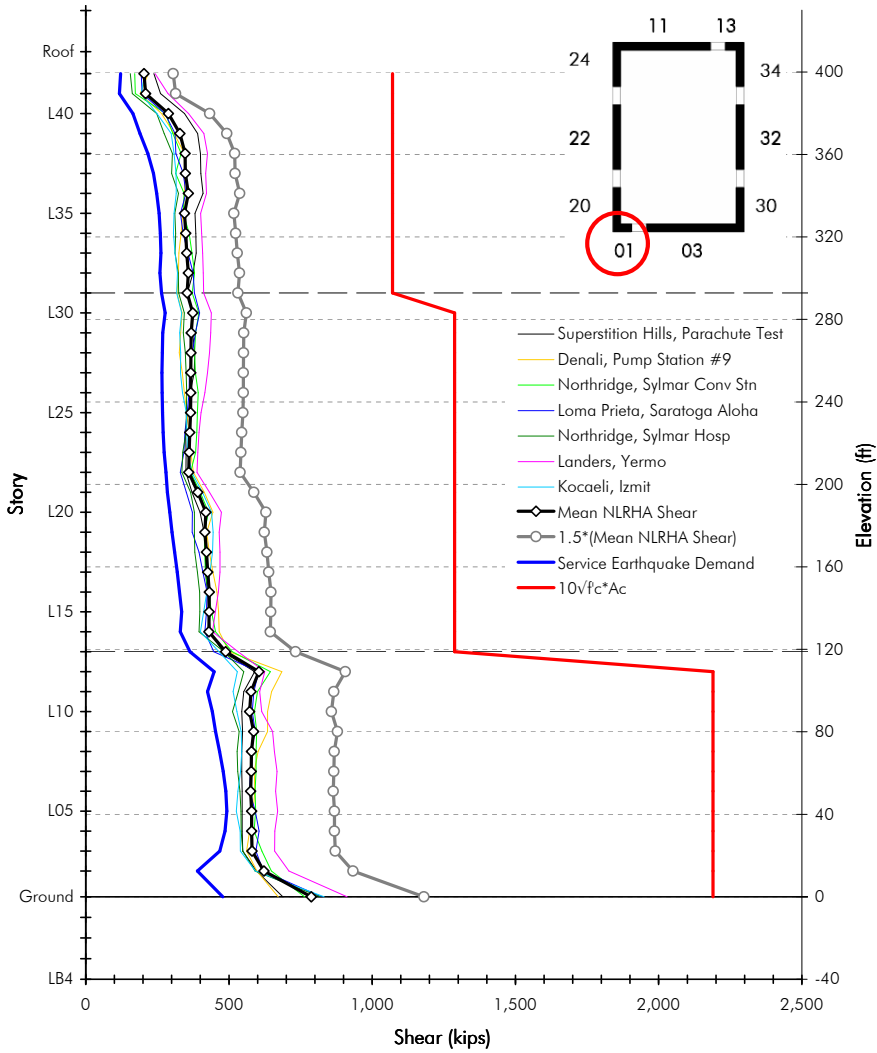

PEER TBI - Building 1C - Core Only Building for CSSC

Core Wall Shear Pier 13

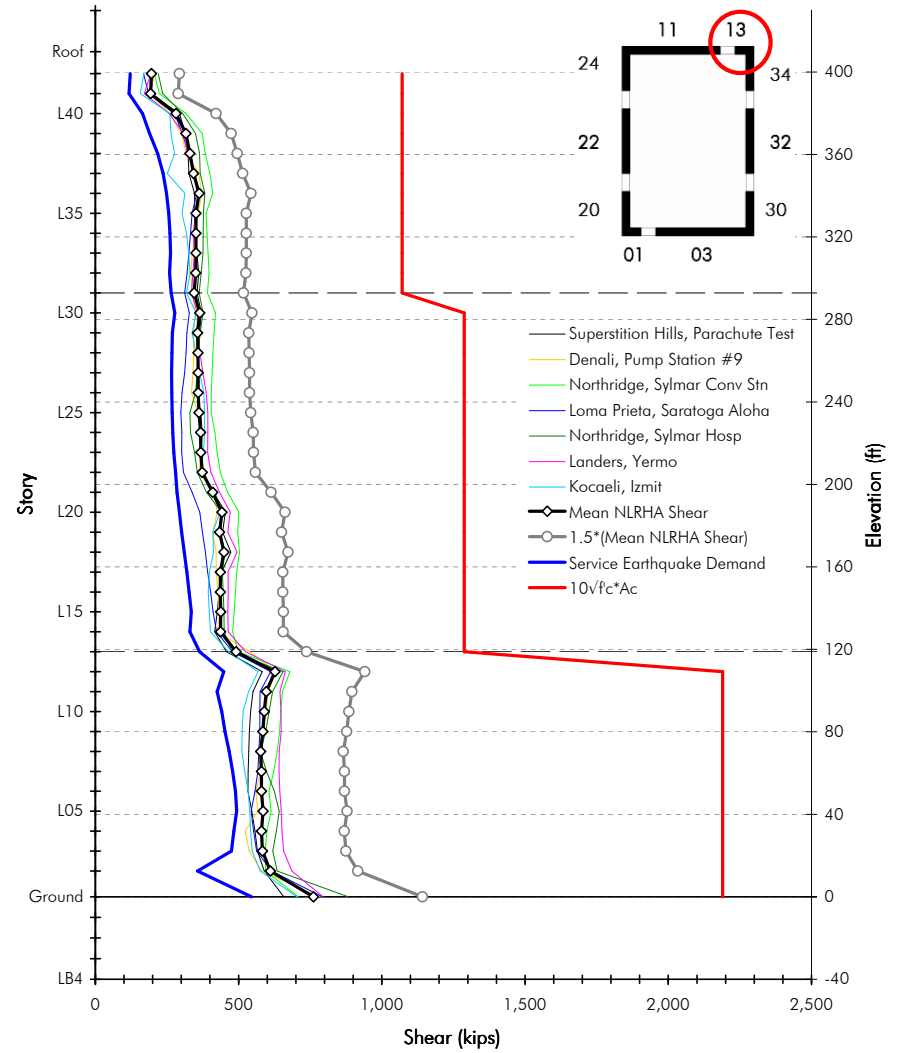

PEER TBI - Building 1C - Core Only Building for CSSC

Building 1B

Core Wall Shear Pier 03

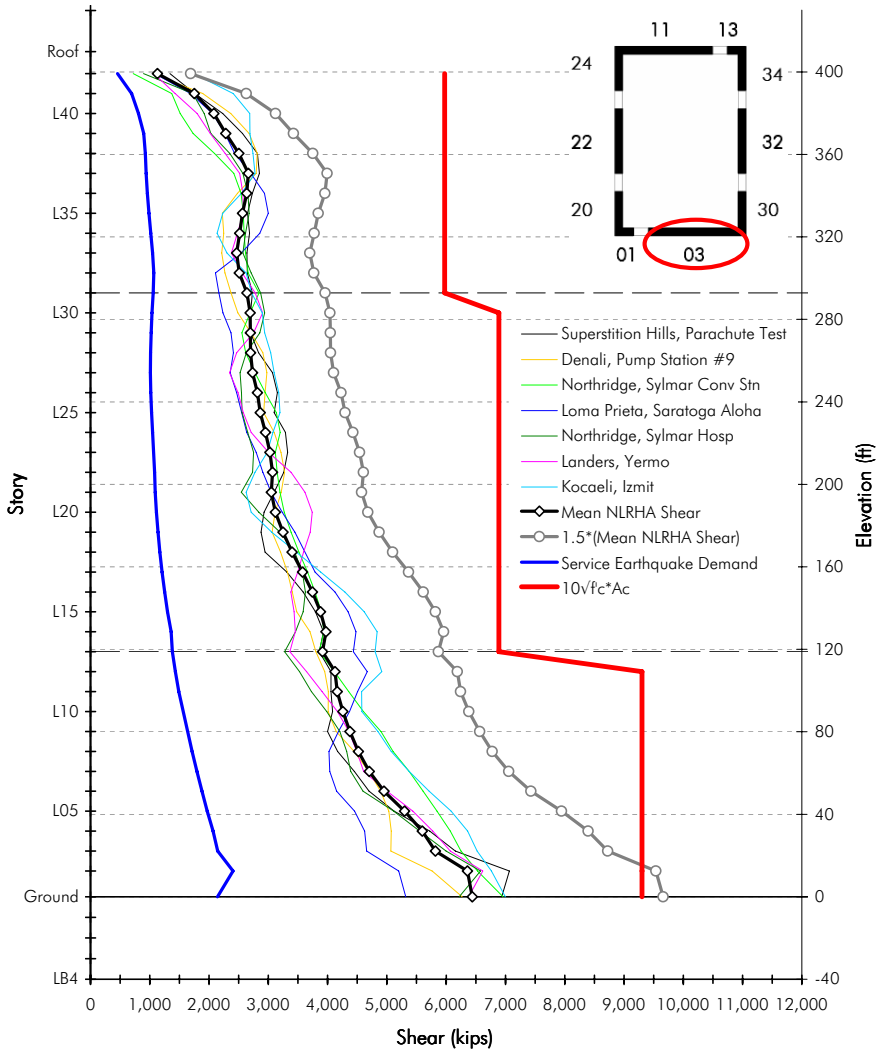

PEER TBI - Building 1B - Core Only Building for CSSC

Core Wall Shear Pier 11

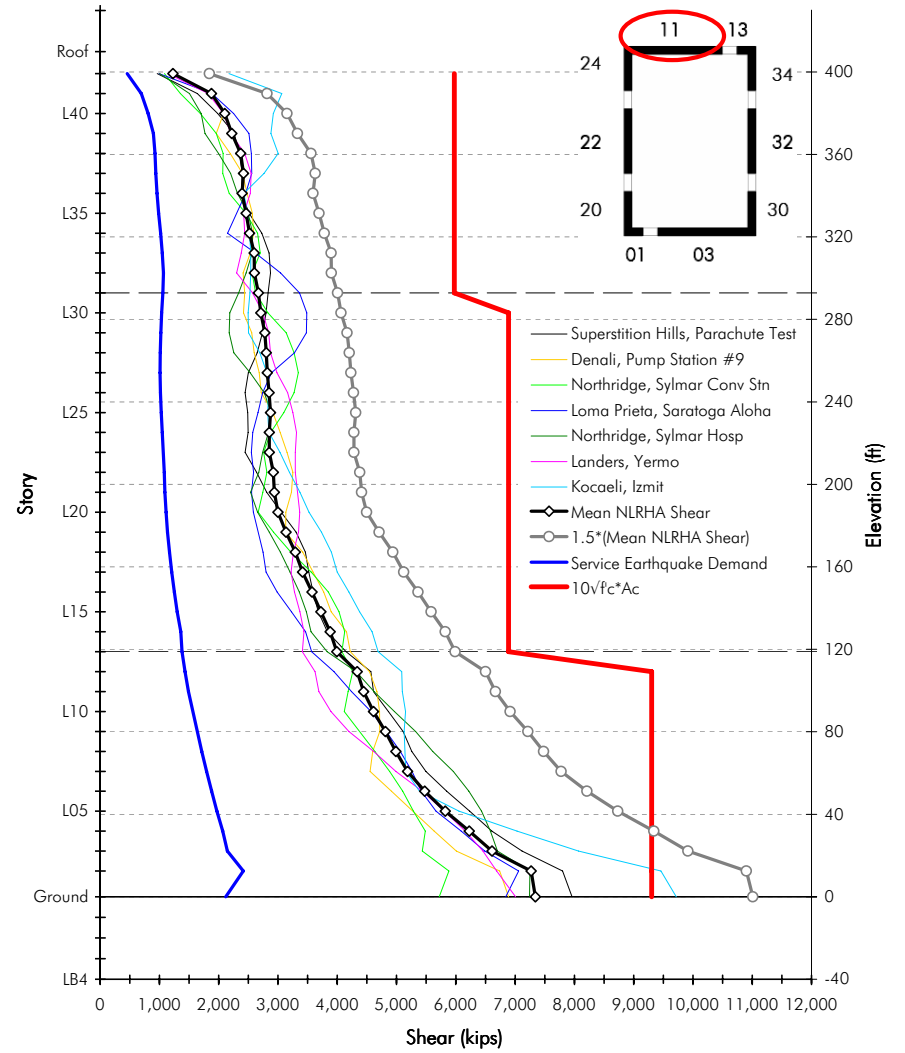

PEER TBI - Building 1B - Core Only Building for CSSC

Building 1C

Core Wall Shear Pier 03

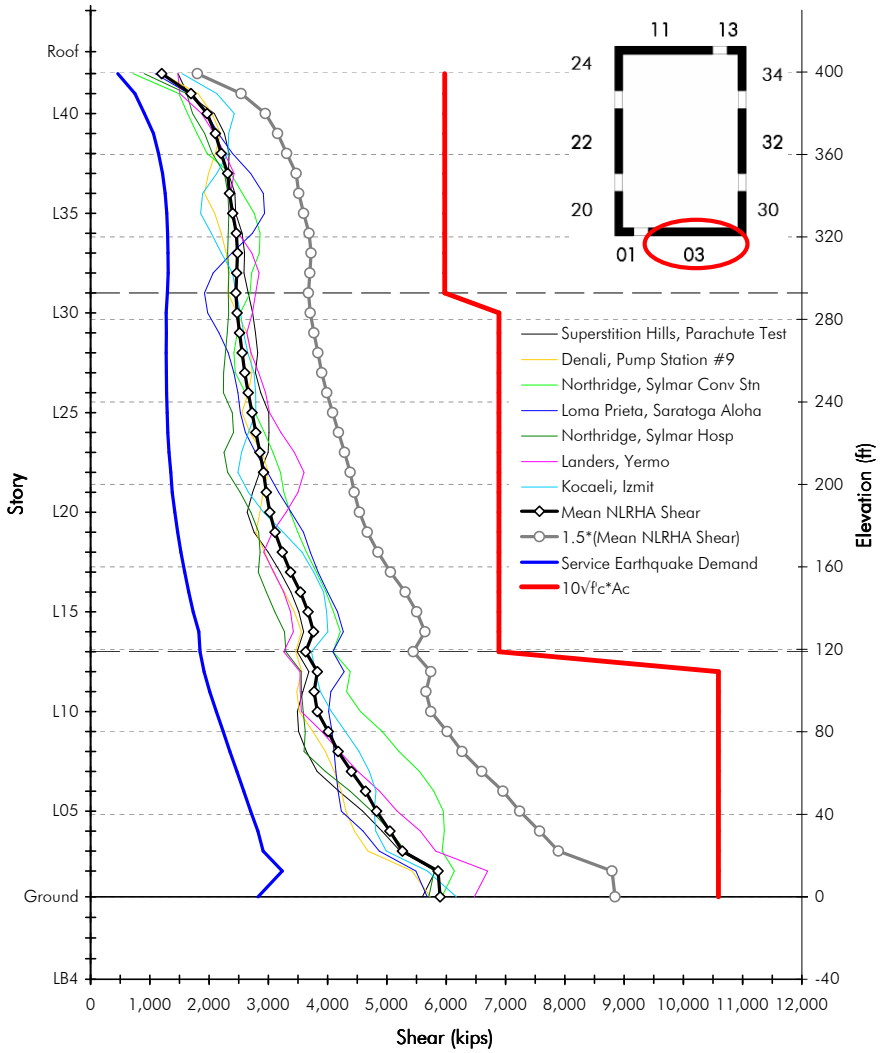

PEER TBI - Building 1C - Core Only Building for CSSC

Core Wall Shear Pier 11

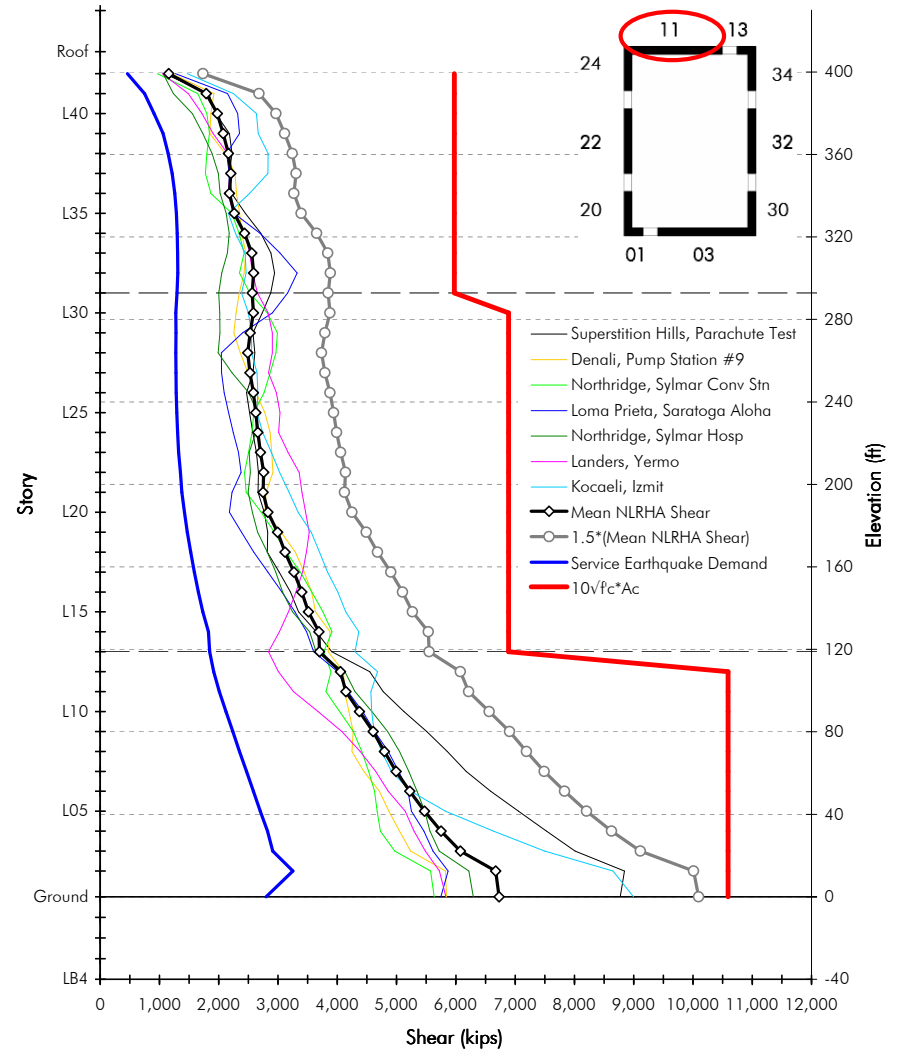

PEER TBI - Building 1C - Core Only Building for CSSC

Building 1B

Core Wall Shear Pier 20

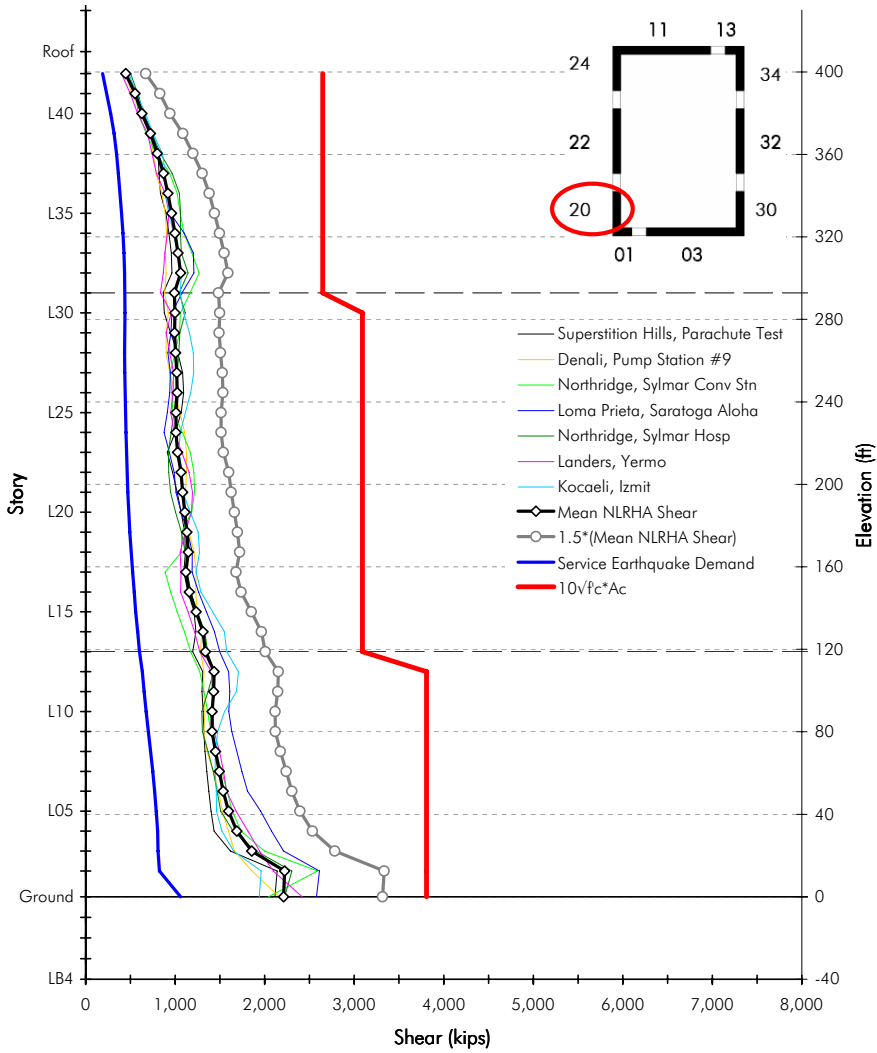

PEER TBI - Building 1B - Core Only Building for CSSC

Core Wall Shear Pier 34

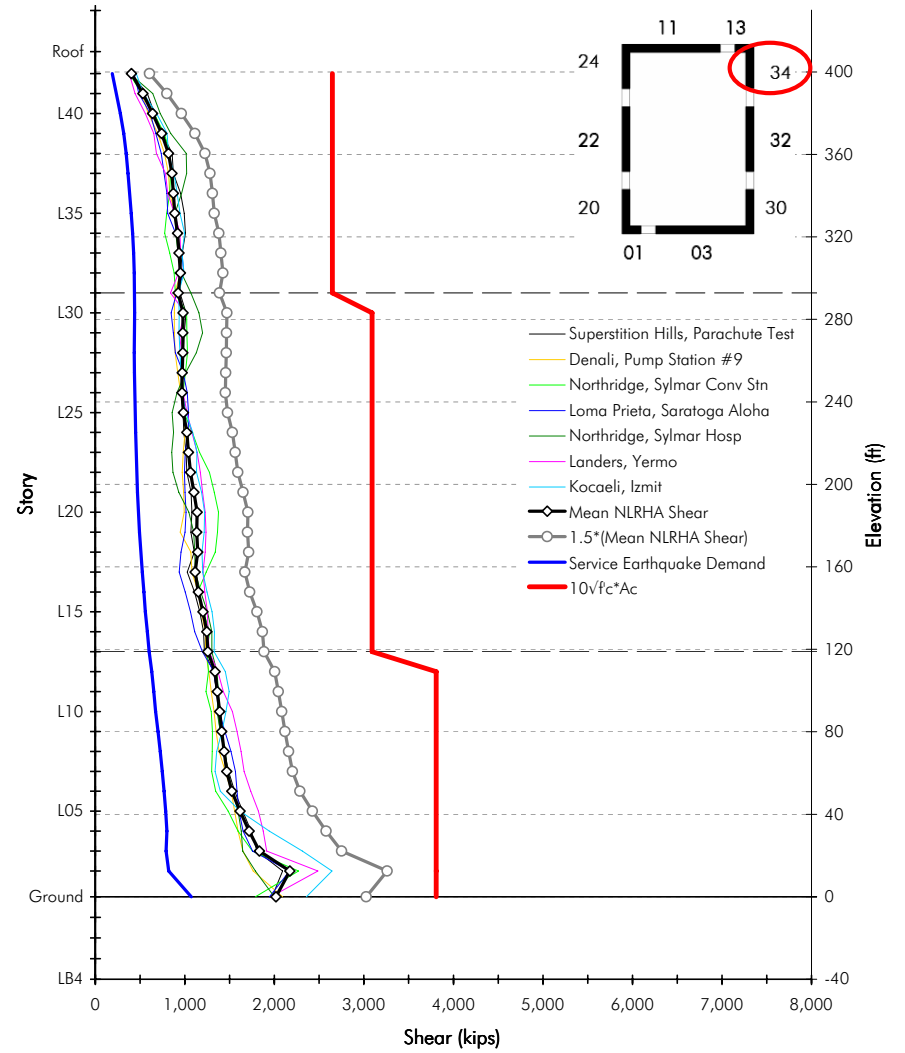

PEER TBI - Building 1B - Core Only Building for CSSC

Building 1C

Core Wall Shear Pier 20

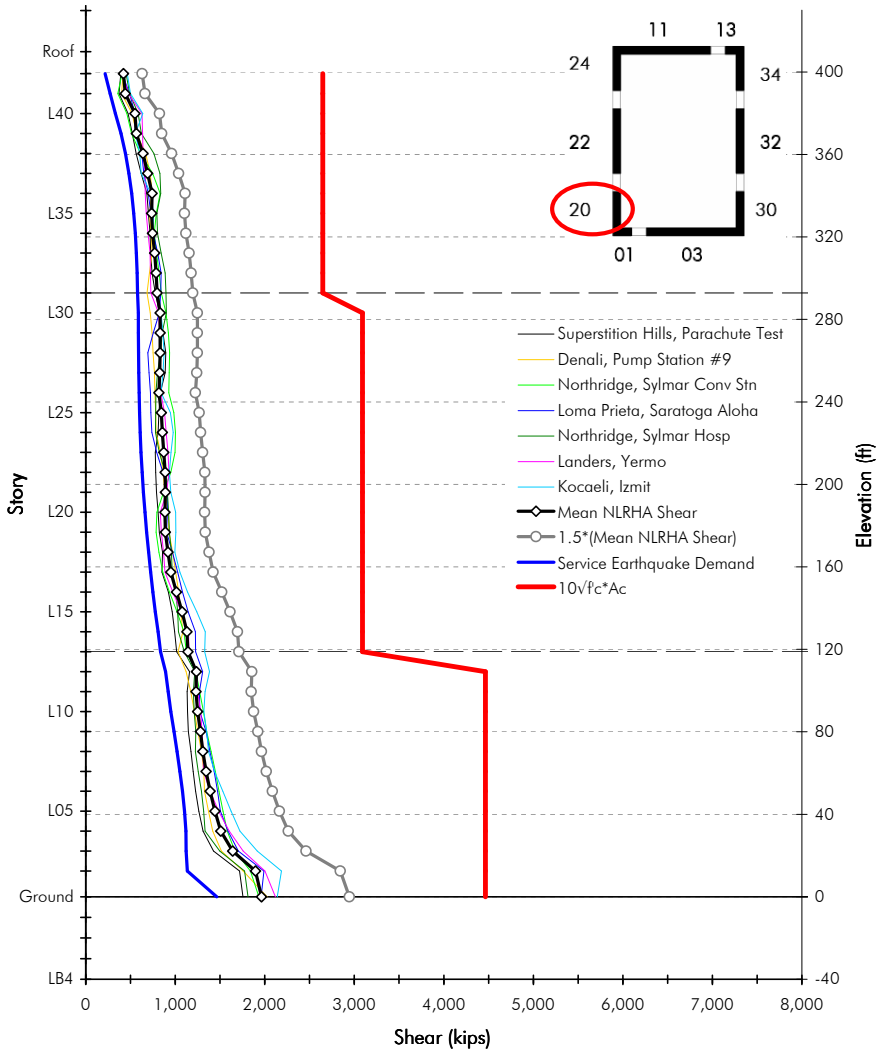

PEER TBI - Building 1C - Core Only Building for CSSC

Core Wall Shear Pier 34

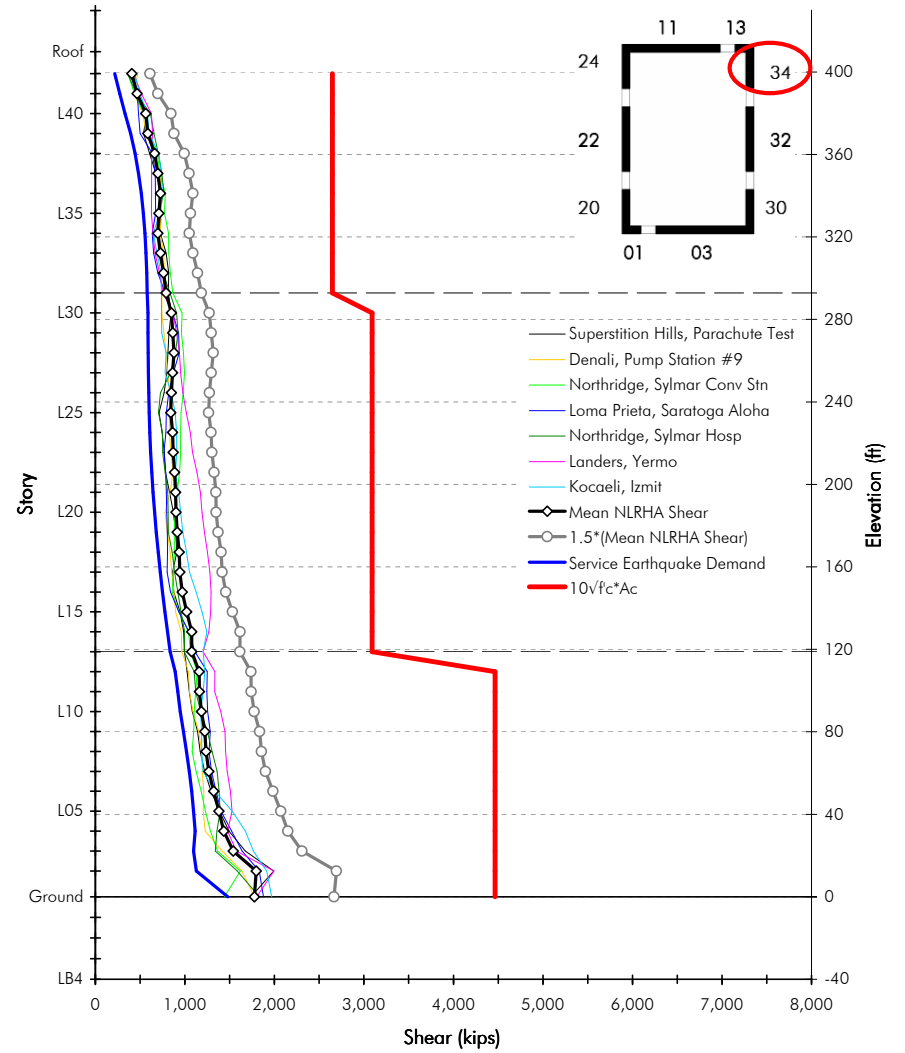

PEER TBI - Building 1C - Core Only Building for CSSC

Building 1B

Core Wall Shear Pier 22

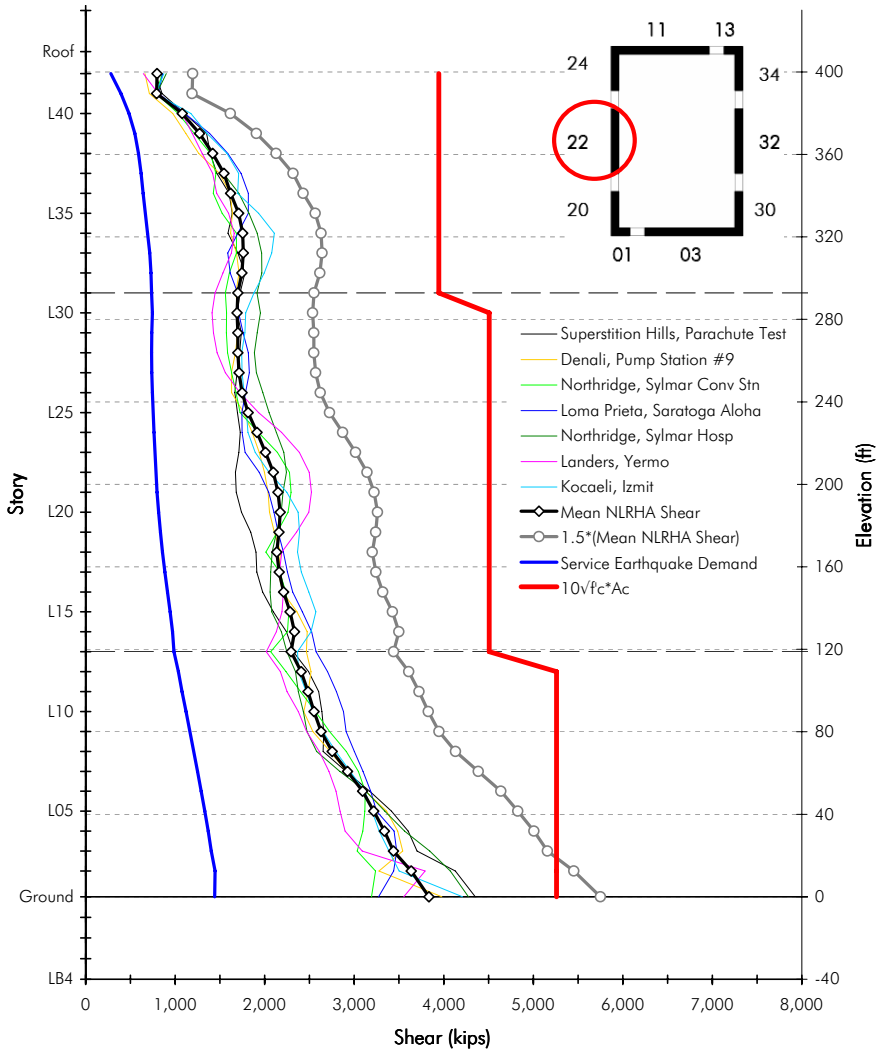

PEER TBI - Building 1B - Core Only Building for CSSC

Core Wall Shear Pier 32

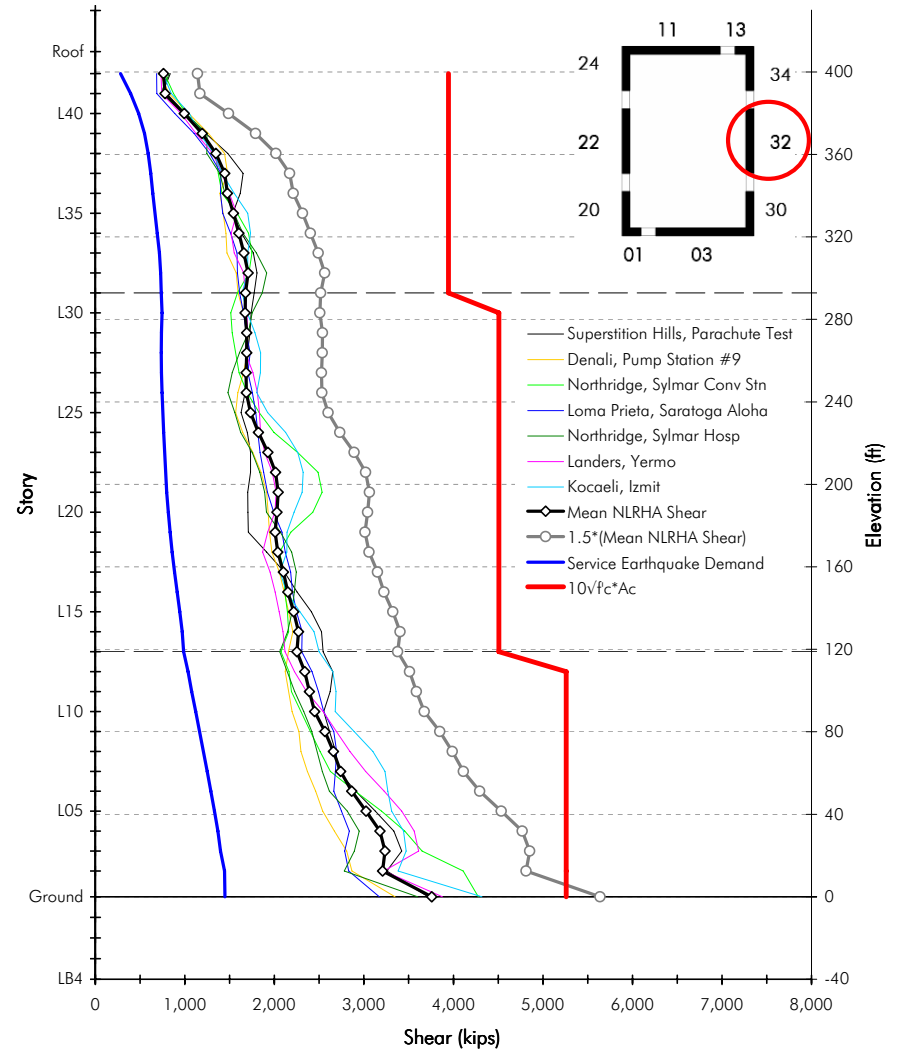

PEER TBI - Building 1B - Core Only Building for CSSC

Building 1C

Core Wall Shear Pier 22

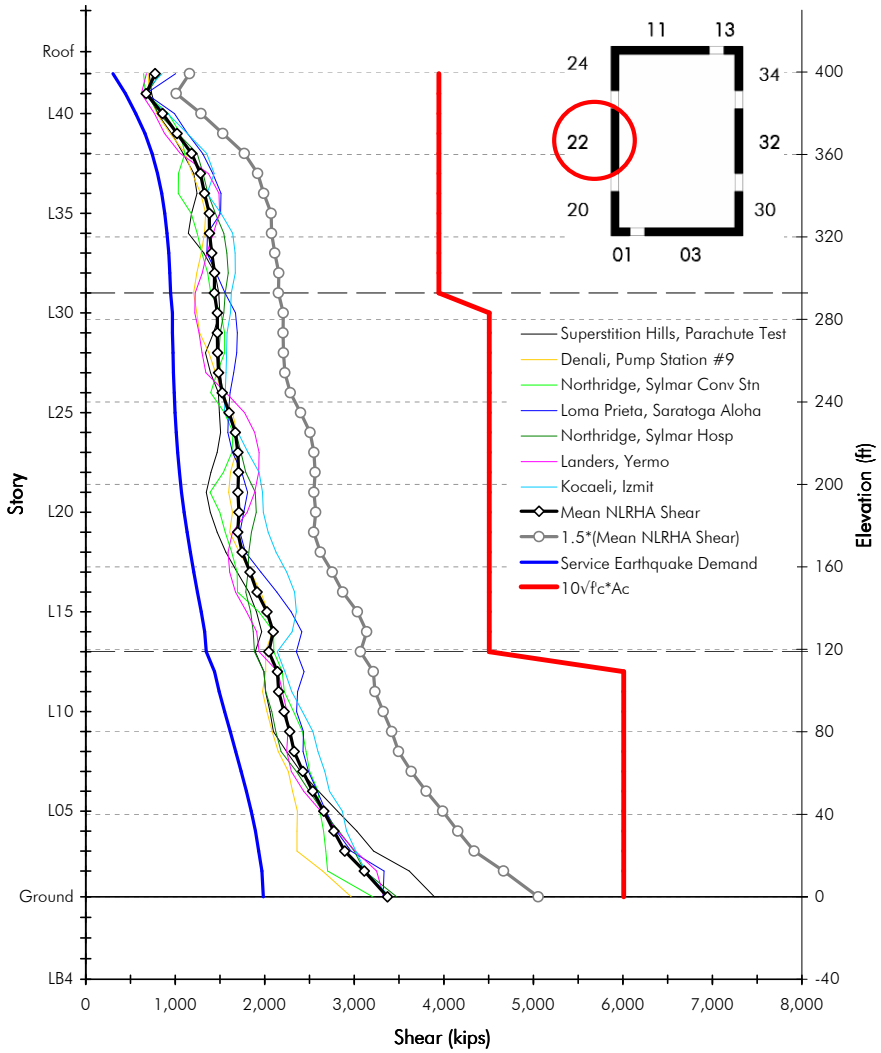

PEER TBI - Building 1C - Core Only Building for CSSC

Core Wall Shear Pier 32

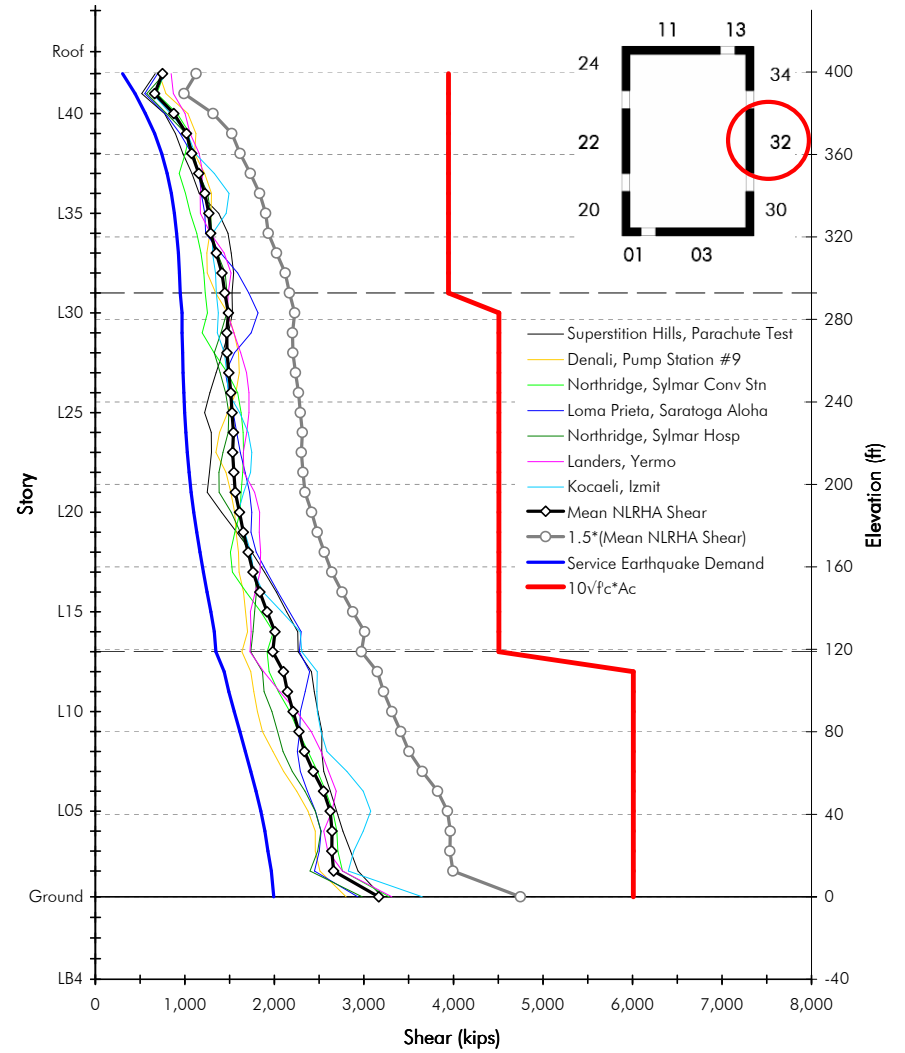

PEER TBI - Building 1C - Core Only Building for CSSC

Building 1B

Core Wall Shear Pier 24

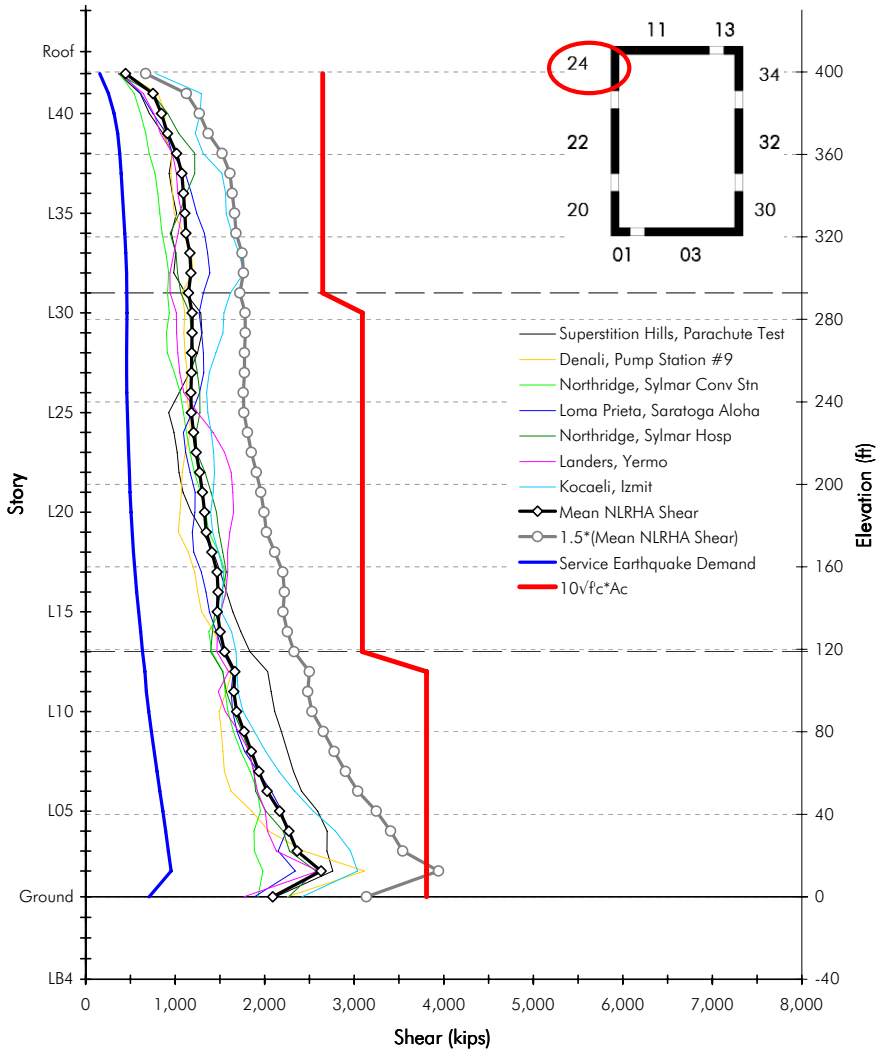

PEER TBI - Building 1B - Core Only Building for CSSC

Core Wall Shear Pier 30

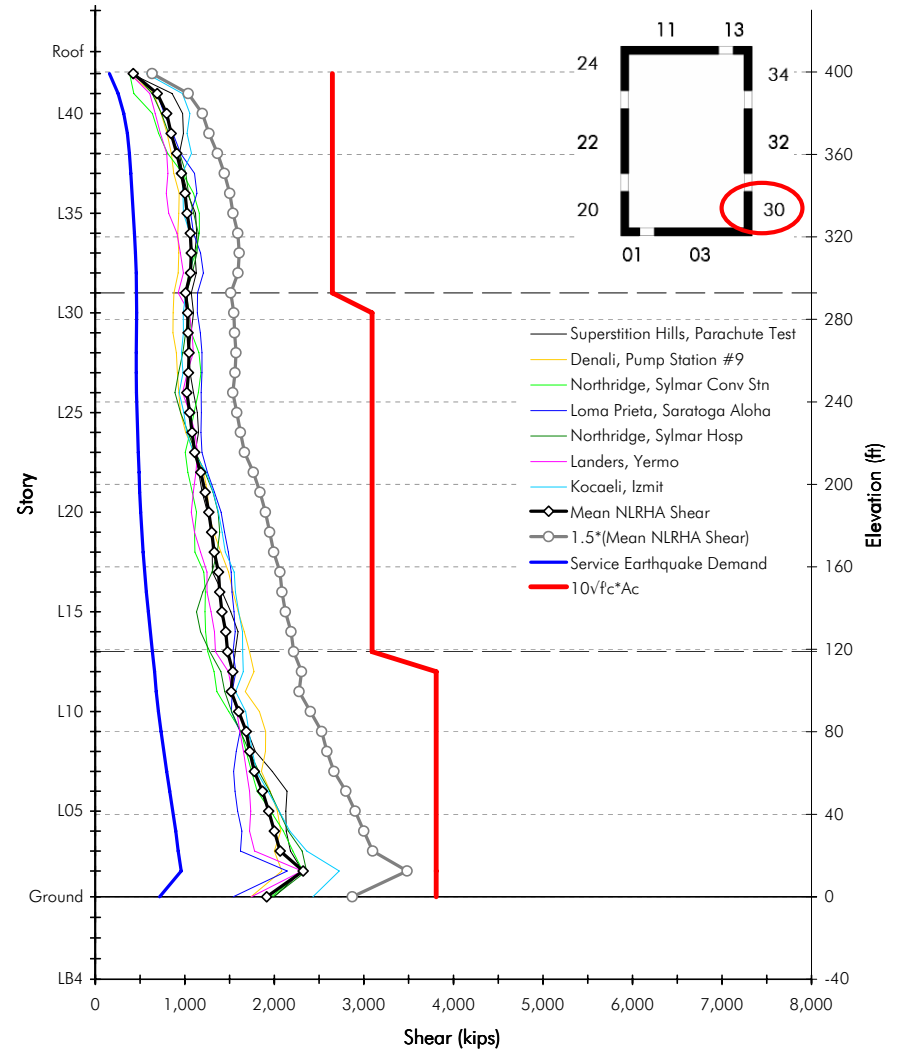

PEER TBI - Building 1B - Core Only Building for CSSC

Building 1C

Core Wall Shear Pier 24

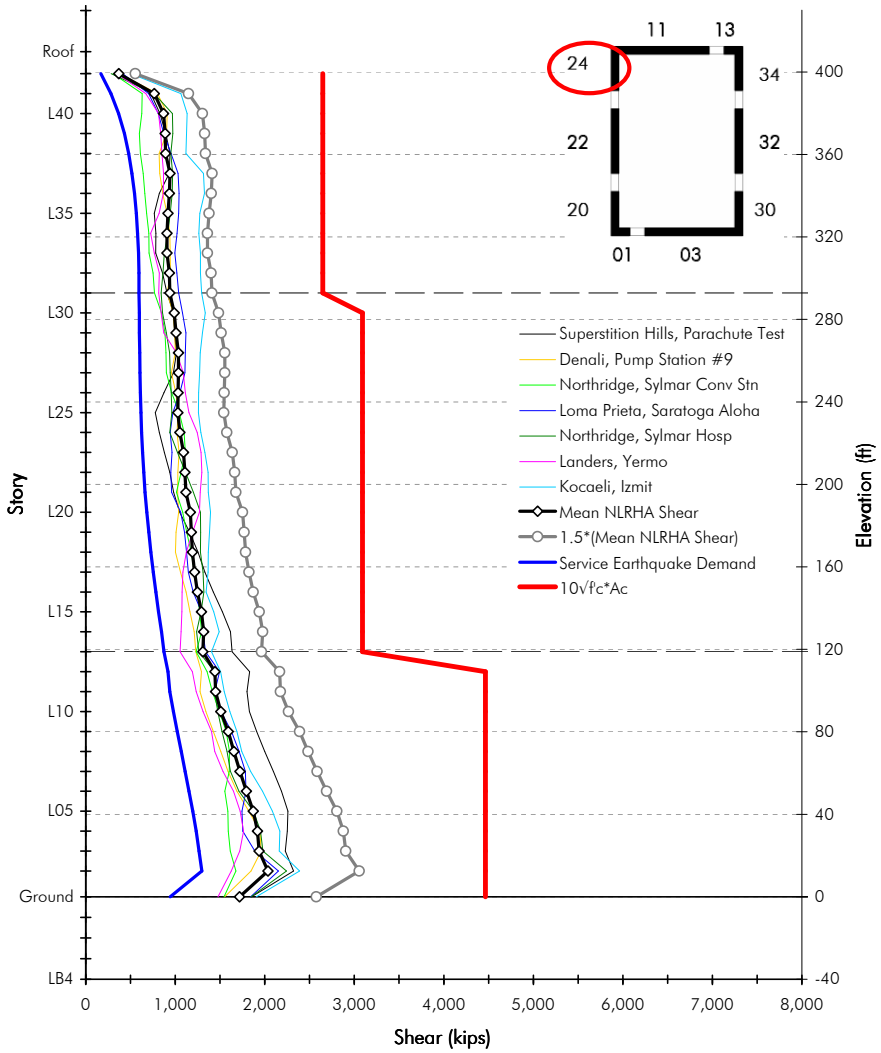

PEER TBI - Building 1C - Core Only Building for CSSC

Core Wall Shear Pier 30

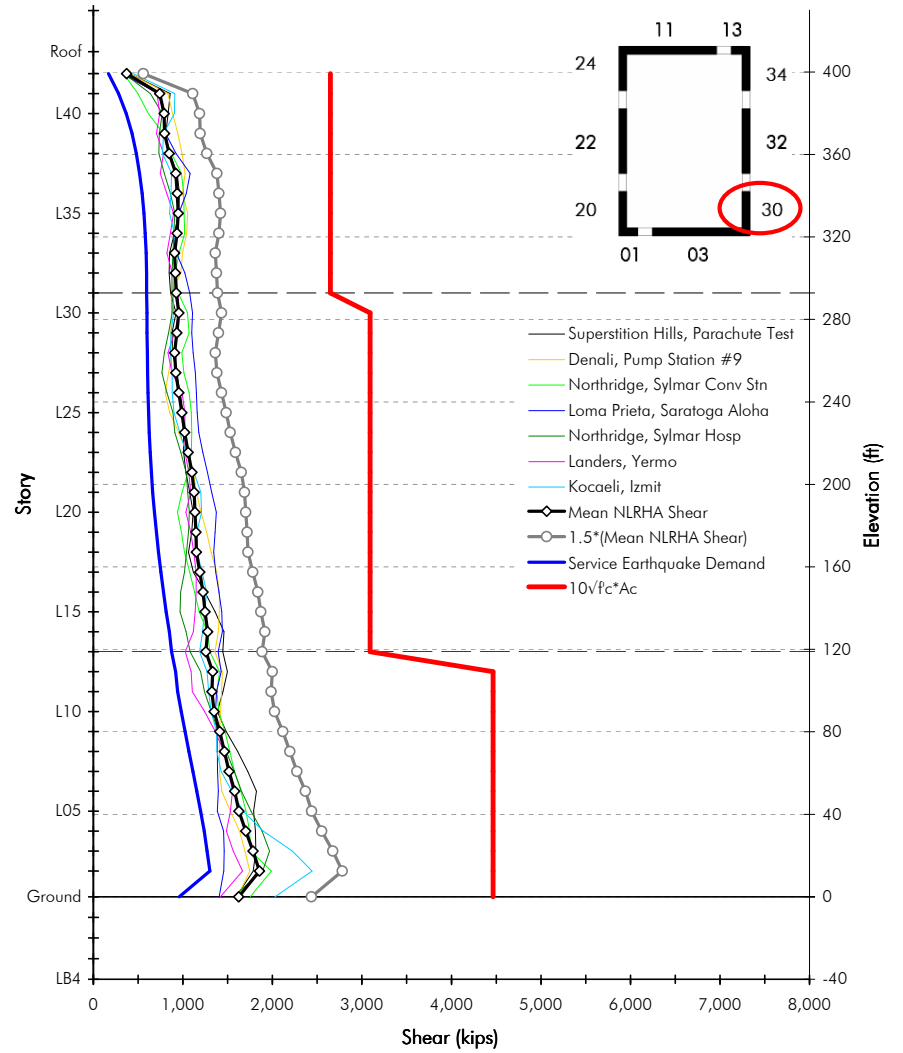

PEER TBI - Building 1C - Core Only Building for CSSC

**Appendix B: 8 Yg][b Report'Zcf'6 i]X]b['&!!
Core Wall / Special Moment Frame
Dual Structural System**



PEER/SSC TALL BUILDING DESIGN CASE STUDY #2

*Tony Ghodsi
Jose A. Flores Ruiz
Claire Massie
Yangbo Chen*



Table of Contents

1.0	Dual System Basis of Design.....	1
2.0	General Building Properties	4
2.1	Stiffness Assumptions	5
3.0	Building 2A - Analysis Summary.....	6
3.1	Building 2A - Seismic Design	6
3.2	Building 2A - Wind Design.....	15
4.0	Building 2B - Analysis Summary.....	16
4.1	Serviceability Analysis Seismic Force Determination.....	21
4.1.1	Service Level Design Acceptance Criteria	22
4.2	Collapse Prevention Step by Step Non-linear Analysis.....	25
4.2.1	Collapse Prevention Acceptance Criteria.....	26
4.2.2	Core Wall Modeling Properties	27
4.2.3	Coupling Beam Modeling Properties.....	33
4.2.4	Moment Frame Beam Properties	37
4.2.5	Moment Frame Column Properties.....	42
4.2.6	Slab Modeling at Ground Level and Below.....	44
4.2.7	Basement Wall Properties.....	46
4.2.8	Damping	47
4.3	Results from Non-linear Analyses	49
4.3.1	Overall Behavior.....	49
4.3.2	Core Shear Wall.....	52
4.3.3	Frame Behavior.....	61
4.3.4	Basement walls	64
	References	65

1.0 Dual System Basis of Design

This report shows the results obtained from two design approaches of a building located in Los Angeles, California, laterally braced by a concrete shear wall elevator core and two four-bay concrete special moment resisting frames (SMRF) in each direction. The building consists of 42 stories and a penthouse above ground level and four subterranean levels. For the purpose of this report, this building is referred to as Building 2.

The design was first based on a modal response spectrum analysis as prescribed by International Building Code 2006 (ICC 2006). The building was then redesigned to satisfy the service level criteria, and then its components were checked to comply with the collapse prevention criteria under the Maximum Considered Seismic Event (MCE) as described in Los Angeles Tall Building Structural Design Council “An Alternative Design Approach for Tall Buildings” (LATBSDC 2008) with the exceptions mentioned under the *Building 2B Analysis Summary* section. The resulting structure with its components designed per IBC 2006 is referred to as Building 2A, and the structure with its components designed and revised to comply with the service and MCE level of forces is referred to as Building 2B.

In all cases the X direction of the building is parallel to letter-gridlines and the Y direction parallel to number-gridlines as shown in Figure 3.

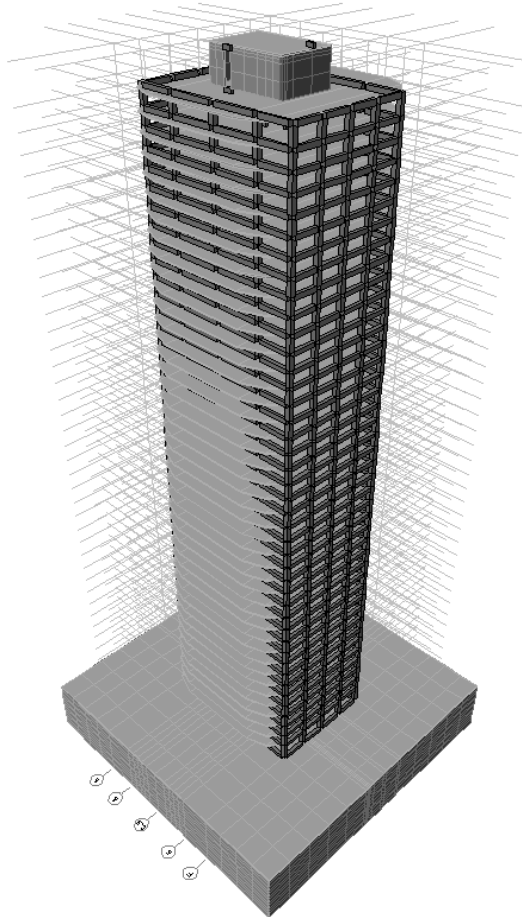

Figure 1 - Three dimensional rendering of structure from ETABS (2008) model

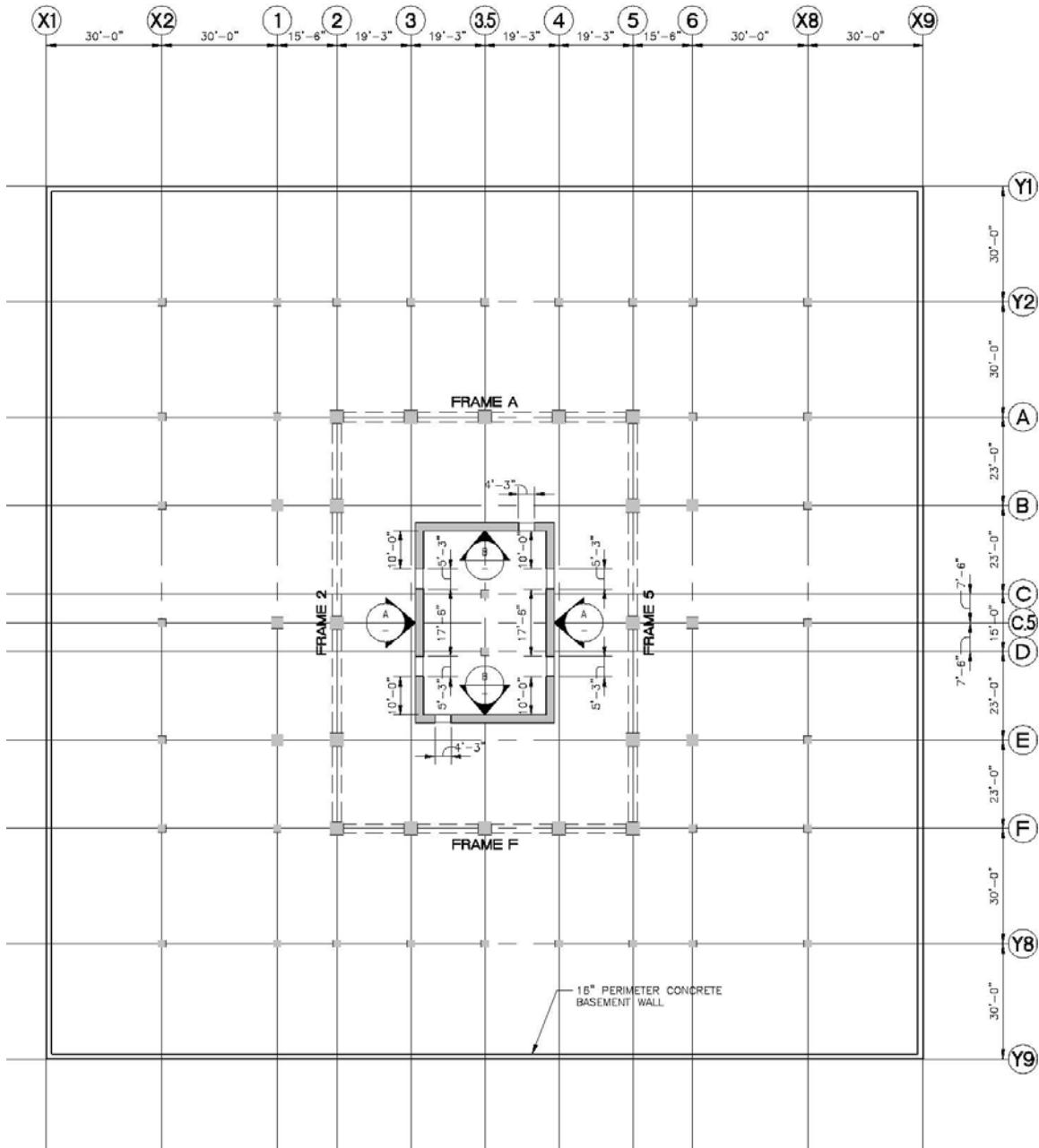

Figure 2 - Typical plan view at ground floor and below

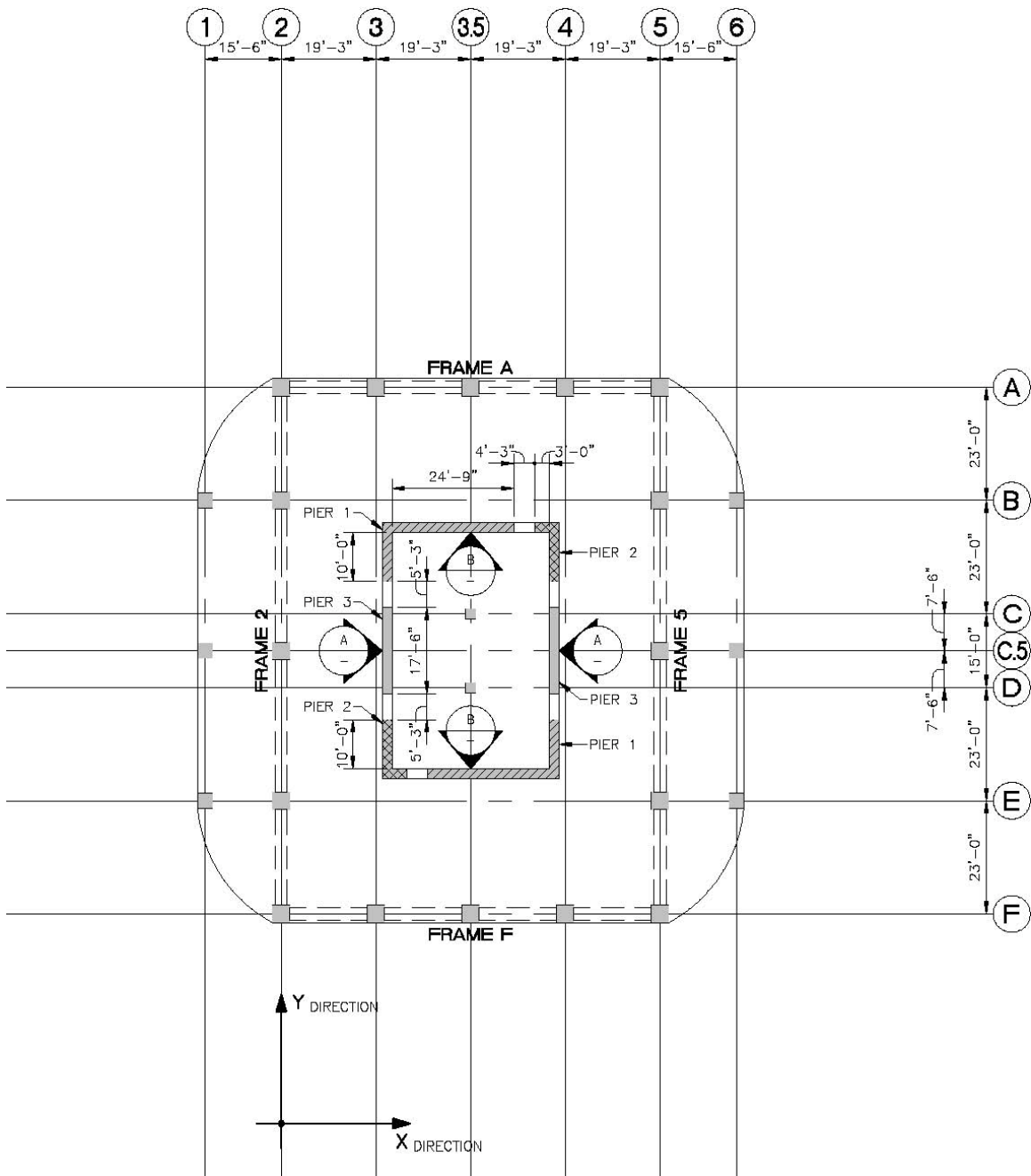

Figure 3 - Typical plan view at level 2 and above



2.0 General Building Properties

Figures 2 and 3 show the typical plan view of the ground floor and below and of the second level and above. Table 1 shows the general building properties.

Table 1 – General Building Properties

Story Height	10.5' At levels below Ground 13.67' From ground to 2 nd 10.5' Typical from 2 nd to 42 nd 11.5' Roof 20' Pent-house
Number of Stories	42 above ground plus Pent-house 4 below ground
Slab Construction	10" thick reinforced concrete at Basement levels 12" thick reinforced concrete at Ground floor 8" thick post-tensioned concrete typical above Ground 10" thick reinforced concrete at Roof
Coupling Beam Depth	30" Typical
Basement Shear Walls	16" thick, $f'_c = 5\text{ksi}$
Moment Frames	(2) 4-bay SMRF in each direction

In addition to the self-weight of the structure, the loads listed in Table 2 are used for the calculation of superimposed dead and live loads.

Table 2 – Load Criteria

Use	Location	Superimposed dead load (psf)	Live Load (psf)
Parking	4 stories below ground	3	50 (Reducible)
Retail	Ground Level inside area	110	100 (Non-Reducible)
Cladding	Perimeter of tower	15 psf per elevation	
Outside Plaza	Ground level outside area	350	100 (Non-Reducible)
Corridors and Exit Areas	Inside elevator core	28	100 (Non-Reducible)
Residential	2 nd floor up to 42 nd floor	28	40 (Reducible)
Mechanical	At roof floor only	100 kip	25 (Reducible)
Roof	Roof floor	28	20 (Reducible)

2.1 Stiffness Assumptions

The stiffness assumptions are listed in Table 3. When non-linear behavior of elements is modeled, stiffness modifiers are applied to the assumed “*elastic*” portion of the force-displacement relationship.

Table 3 - Stiffness Assumptions

Element	Building 2A	Building 2B	
	Code-Level Analysis	Serviceability Design	MCE Level
Modulus of Elasticity ^A	Specified concrete strength	Expected concrete strength ^B	Expected concrete strength
Core Walls	Flexural – 0.6 EI _g Shear – 1.0 GA _g	Flexural – 0.9 EI _g Shear – 1.0 GA _g	Flexural – <i>See note C</i> Shear – 1.0 GA _g
Basement Walls	Flexural – 0.8 EI _g Shear – 0.8 GA _g	Flexural – 1.0 EI _g Shear – 1.0 GA _g	Flexural – 0.8 EI _g Shear – 0.8 GA _g
Coupling Beams	Flexural – 0.2 EI _g Shear – 1.0 GA _g	Flexural – 0.5 EI _g Shear – 1.0 GA _g	Flexural – 0.2 EI _g Shear – 1.0 GA _g
Ground Level and Basement slabs	Flexural – 0.25 EI _g Shear – 0.5 GA _g	Flexural – 0.5 EI _g Shear – 0.8 GA _g	Flexural – 0.25 EI _g Shear – 0.25 GA _g
Moment Frame Beams	Flexural – 0.35 EI _g Shear – 1.0 GA _g	Flexural – 0.7 EI _g Shear – 1.0 GA _g	Flexural – 0.35 EI _g Shear – 1.0 GA _g
Moment Frame Columns	Flexural – 0.7 EI _g Shear – 1.0 GA _g	Flexural – 0.9 EI _g Shear – 1.0 GA _g	Flexural – 0.7 EI _g Shear – 1.0 GA _g

A. Modulus of elasticity is based on the following equations:

$$E_c = 57000\sqrt{f'_c} \quad \text{for } f'_c \leq 6000 \text{ psi}$$

$$E_c = 40000\sqrt{f'_c} + 1 \times 10^6 \quad \text{for } f'_c > 6000 \text{ psi} \quad (\text{per ACI 363R-92}^1)$$

B. Per Table 2 of LATBSDC (2008), the expected material strengths are 1.3 f'c for concrete and 1.17 fy for reinforcing steel.

C. Core walls are modeled using fiber sections. *is* used, if the concrete doesn't crack, EI is close to 1.0 times the gross concrete properties (It is slightly bigger because of the steel). As the strains on the fiber elements increase, the effective EI decreases.



3.0 Building 2A - Analysis Summary

The design of Building 2A was performed in general compliance with the IBC 2006, which adopts the ASCE 7 (2006) and ACI 318 (2008).

The specified core wall thickness and strength throughout the height are shown in Table 4. For SMRF properties and for core wall reinforcing see Figures 4 through 7. Table 5 shows the periods of Building 2A using the stiffness assumptions listed in Table 3.

Table 4 – Building 2A Specified Core Wall Thickness and Strength

Thickness	24” from foundation to 20 th 18” Above 20 th
Specified concrete strength (f'_c)	6000 psi from foundation to 20 th 5000 psi Above 20 th
Specified reinforcing strength (f_y)	60 ksi (A706)

Table 5 – Building 2A Code Design Periods

Vibration Mode	Period	Dominant direction	Mass participation
1	5.50 s	Translation mode on X direction	67 %
2	4.97 s	Translation mode on Y direction	68 %
3	2.98 s	Torsional mode	75 %

3.1 Building 2A - Seismic Design

A linear modal response spectrum analysis was used for the seismic design of Building 2A. The design forces were obtained from a provided 5% damped site-specific response spectra scaled in accordance with ASCE 7 (2006), Chapter 21.

Table 6 summarizes the factors used for this analysis. A comparison between the prescribed code spectra and the site-specific spectra is shown in Figure 8.

The model for Building 2A was created using the program ETABS (2008) including only the lateral force resisting elements which were modeled with the stiffness modified to match Table 3. When modeling the structure, concrete shear walls and SMRF are modeled from the foundation level to the penthouse and roof levels, respectively. Soil-structure interaction is ignored and the lateral stiffness of gravity elements is not included.

The design of structural components was based only on the modal analyses results. No special effort other than those prescribed by code was made to detail building 2A.

The representative plots for the design of building 2A are shown in Figures 9 through 13.

Table 6 - Linear Dynamic Site Specific Response Spectrum Analysis Parameters

S_s	1.725 g
S_1	0.602 g
F_a	1
F_v	1.3
S_{Ms}	1.718 g
S_{M1}	0.782 g
S_{DS}	1.145 g
S_{D1}	0.521 g
R	7.0
Site Class	C
C_d	5.5
C_s	0.051 ^A
Seismic Weight (W) ^B	102000 kips
Modal combination method	Complete quadratic combination (CQC)
Redundancy factor (ρ) ^C	1.0
Accidental eccentricity	5%
Base shear "V" (See section 12.8)	5202 kips ^C
Modal Base shear "V _t " (See section 12.9.2)	$V_{ix} = 11436 / R = 1634$ kips $V_{iy} = 11760 / R = 1680$ kips
Modal base shear scaled to match 0.85 V	0.85 x 5202 = 4421 kips

Notes:

- C_s values for both cases are governed by equation 12.8-5 of ASCE 7-05 (2006) as shown in its supplement 2.
- Seismic weight accounts for the dead load of 2nd level and above.
- The structure complies with 12.3.4.2-b, the redundancy factor equals 1.
- Per section 12.9.4 of ASCE 7-05 (2006), "Where the combined response for the modal base shear (V_i) is less than 85 percent of the calculated base shear (V) using the equivalent lateral force procedure, the forces, but not the drifts, shall be multiplied by 0.85 V/V_i ". Hence, for strength design, the modal analyses are scaled to match **0.85V = 4421 kips**.
- Refer to ASCE 7-05 (2006) for the definition of each design parameter.

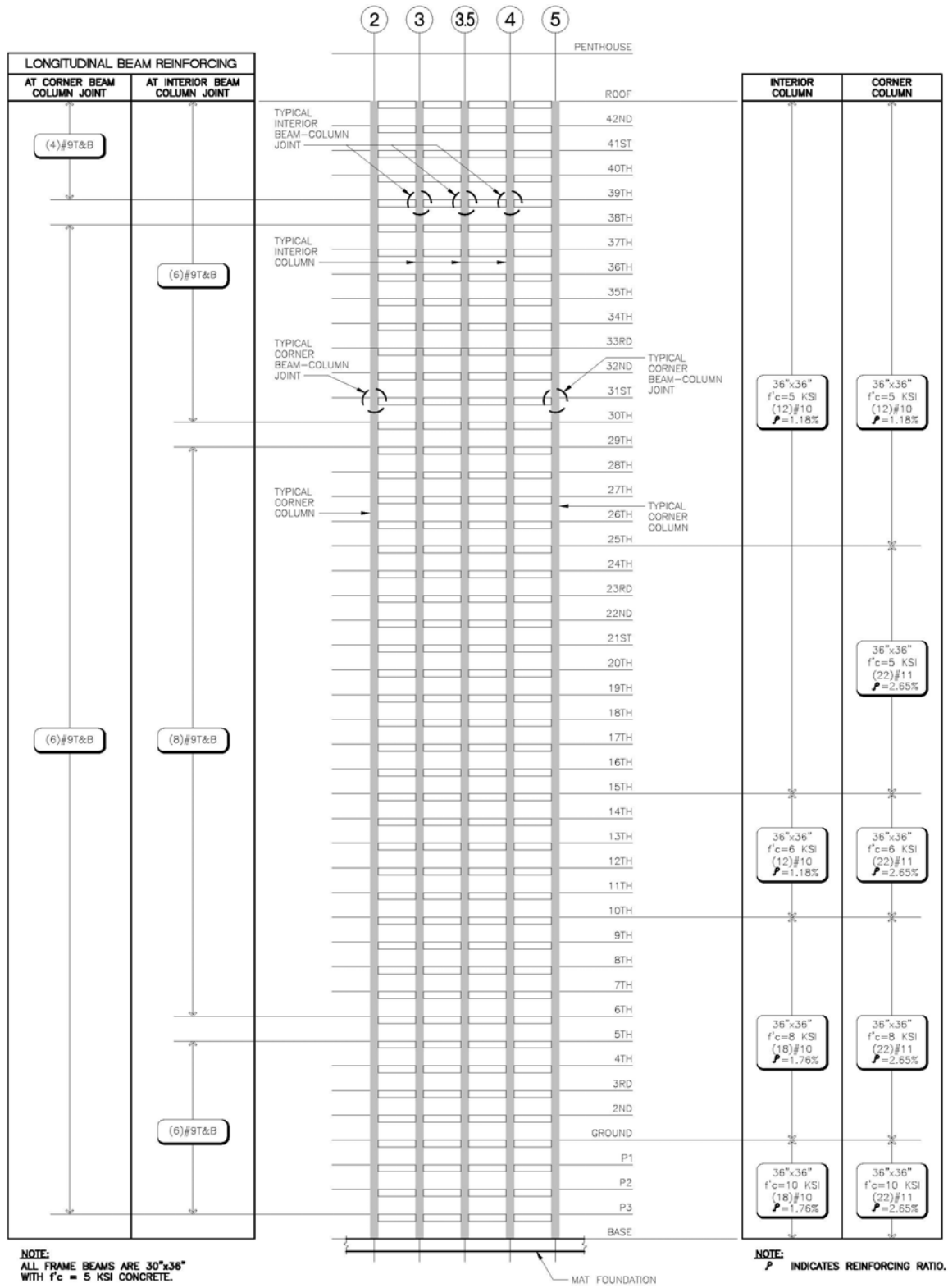

Figure 4 - Elevation and Properties of Frames A and F for Building 2A

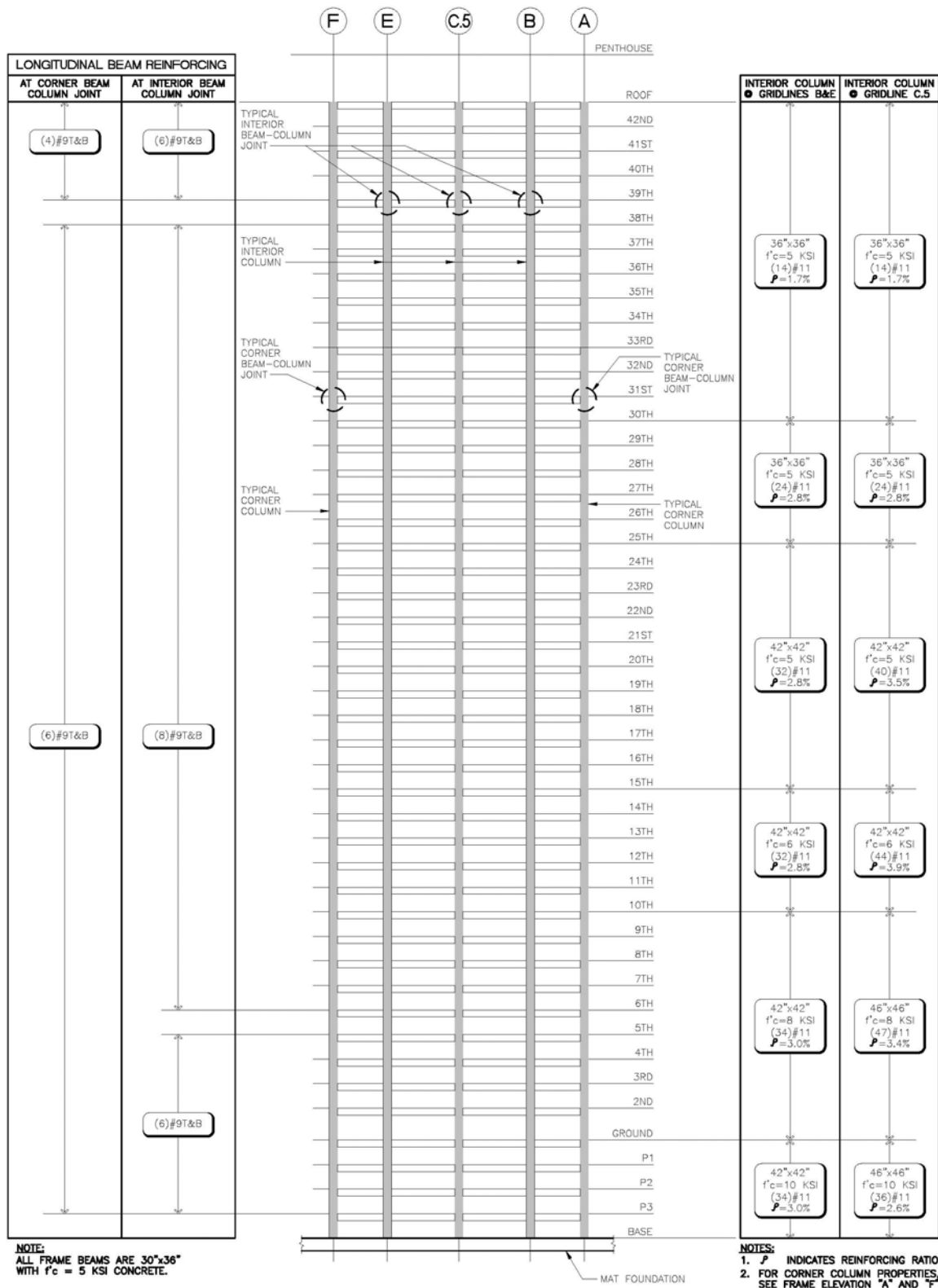

Figure 5 - Elevation and properties of frames 2 and 5 for building 2A

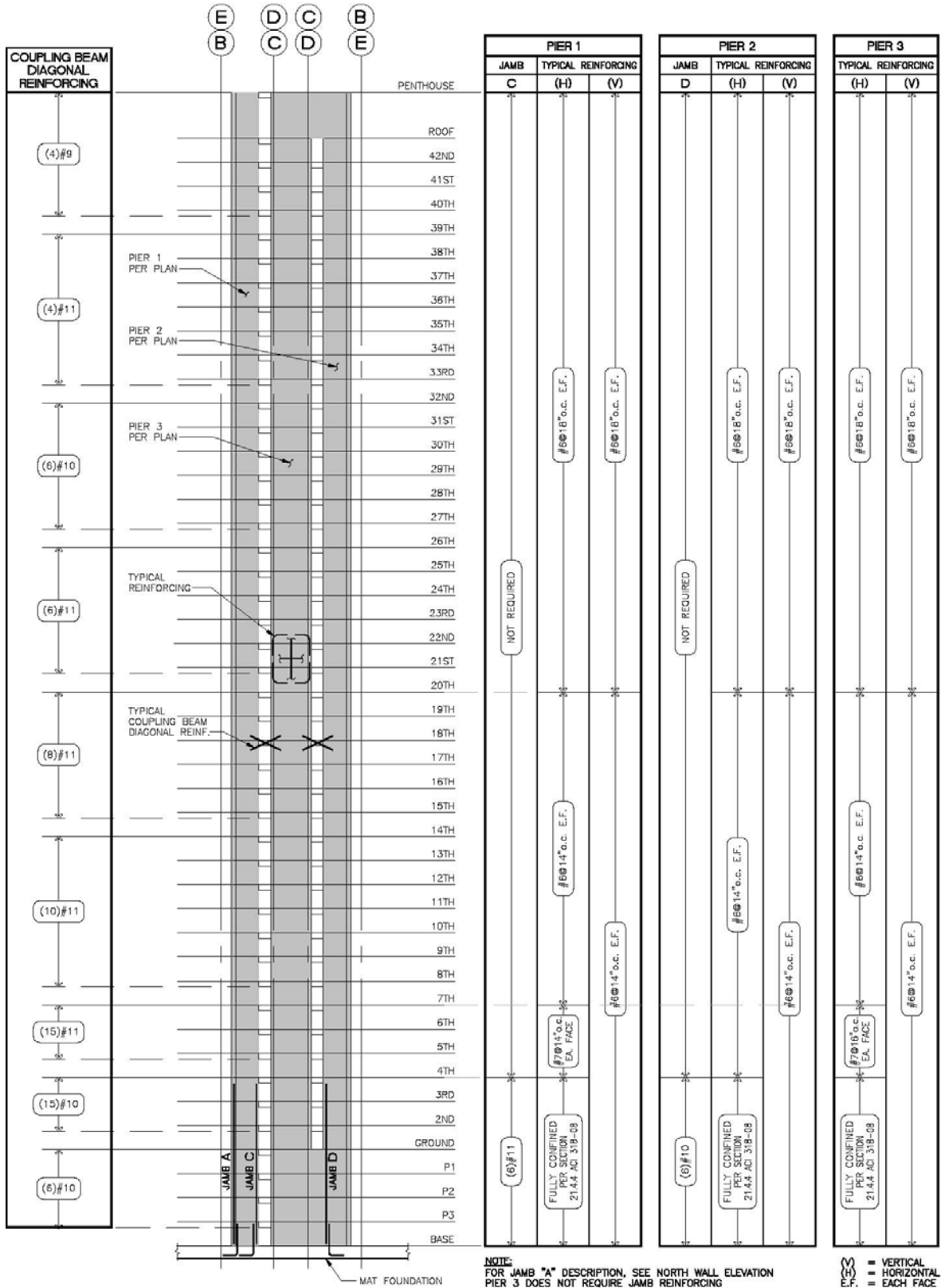

Figure 6 – Elevation A and shear wall reinforcing for building 2A

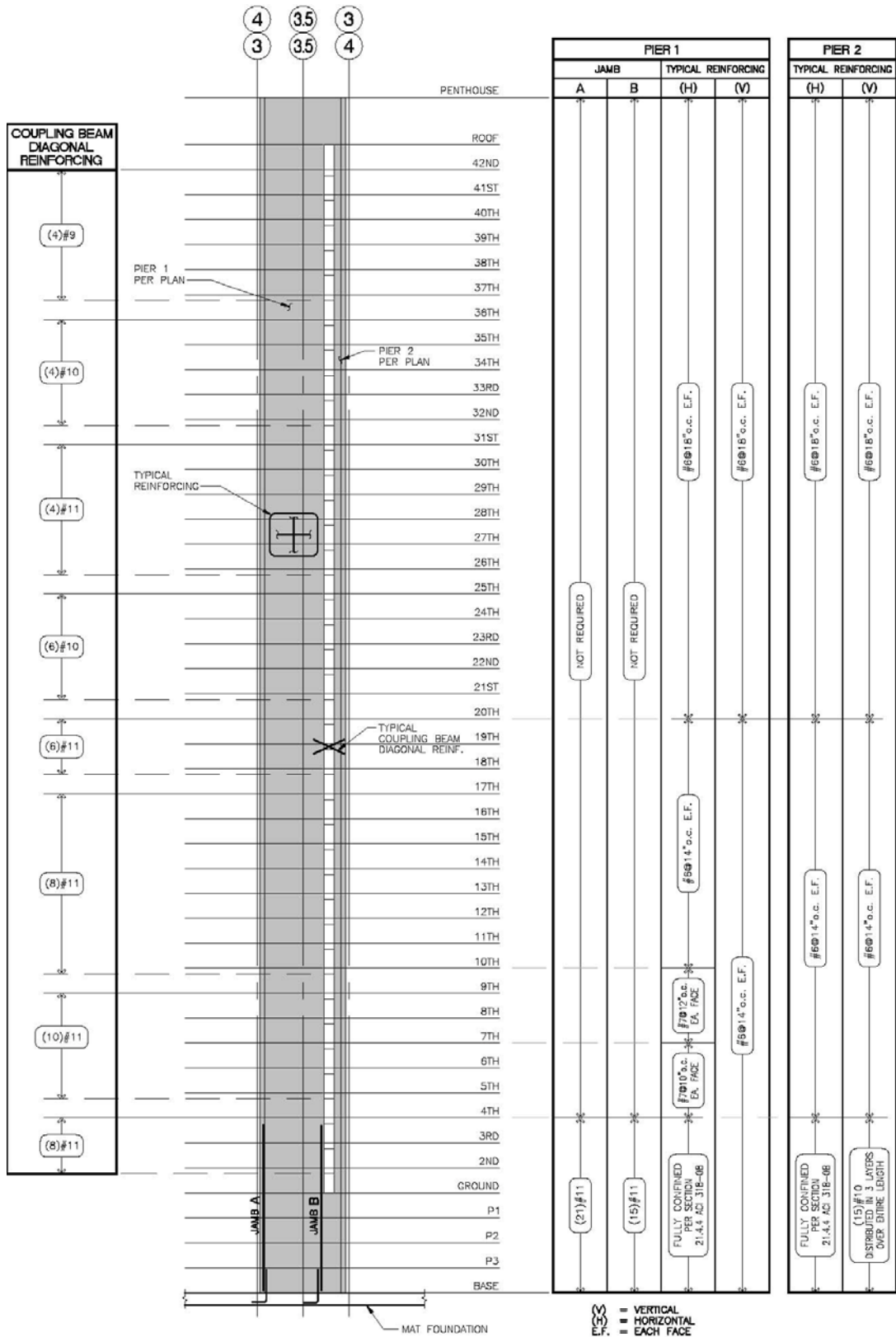

Figure 7 – Elevation B and shear wall reinforcing for building 2A

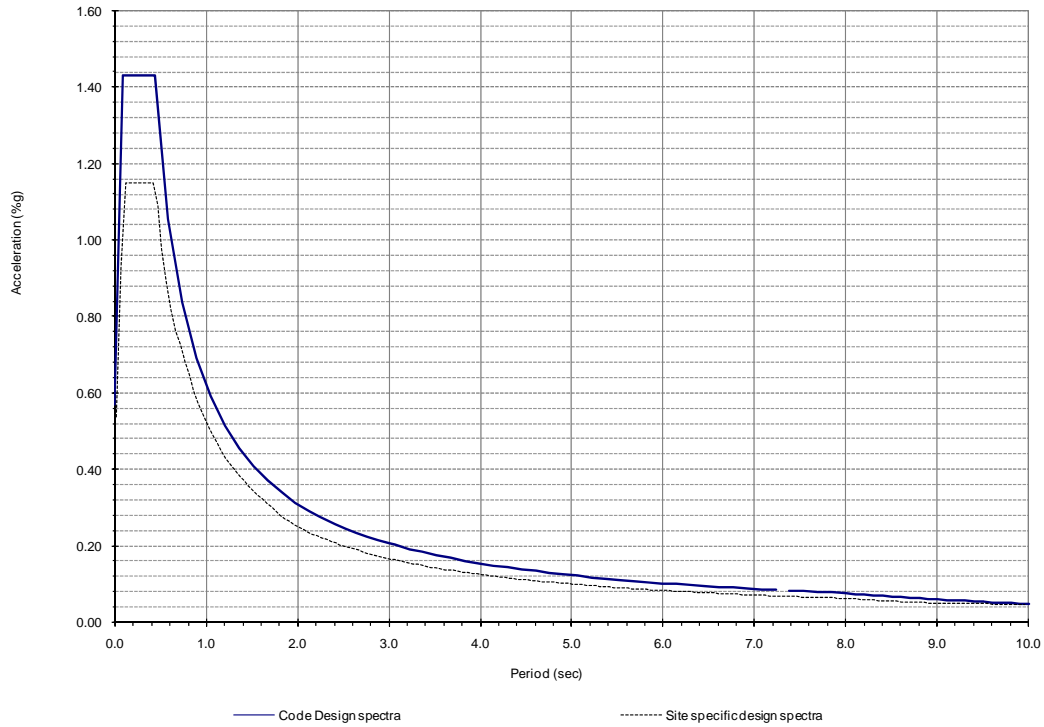

Figure 8 – 5% damped code and site specific design response spectra

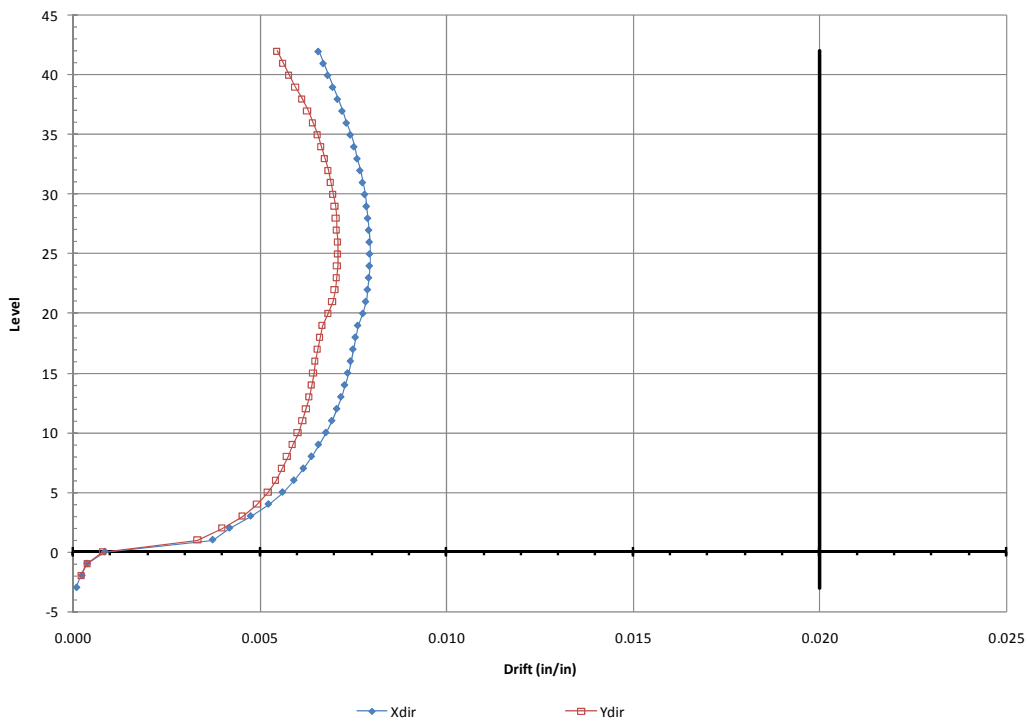

Figure 9 – Building 2A inter-story drifts from seismic forces on X and Y directions

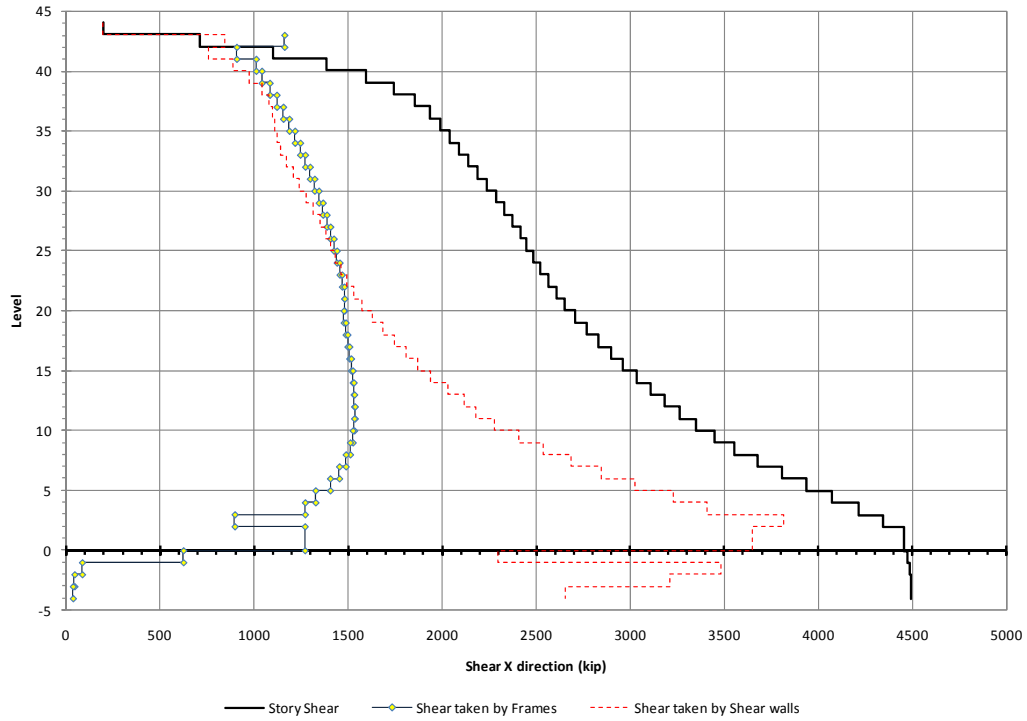

Figure 10 – Building 2A modal analysis peak shear from seismic forces on X direction

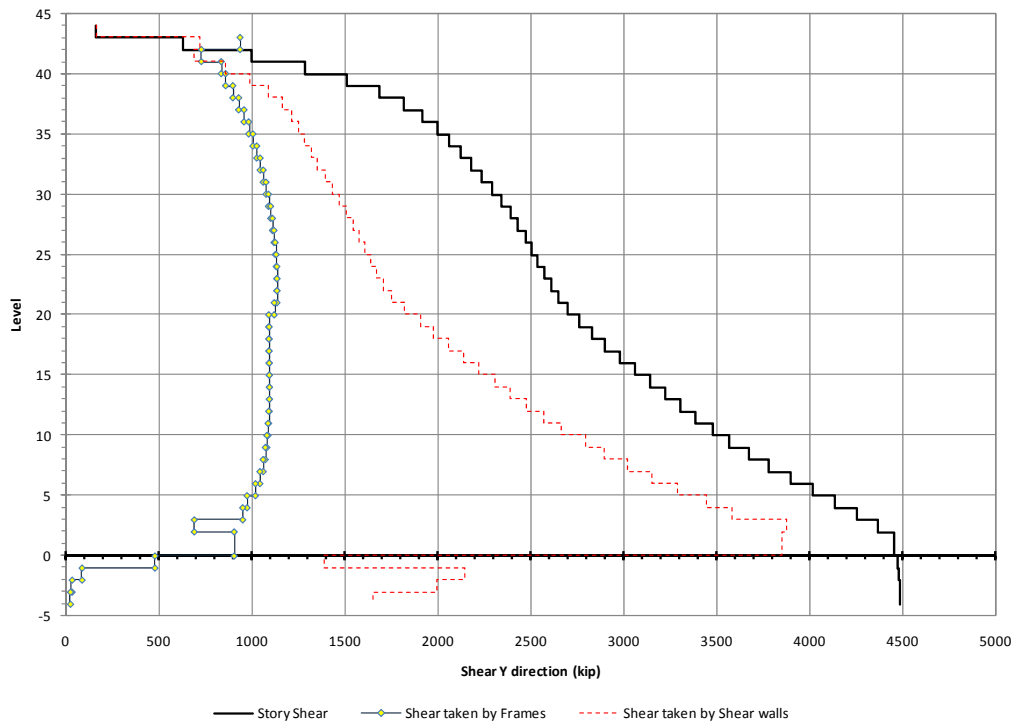

Figure 11 - Building 2A modal analysis peak shear from seismic forces on Y direction

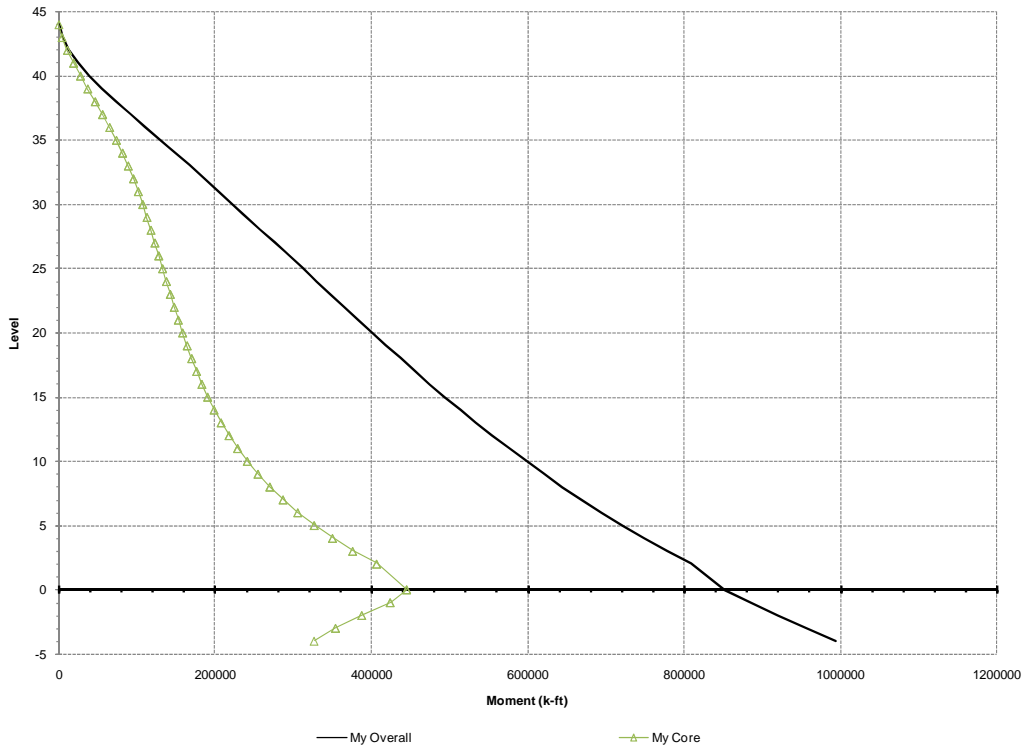

Figure 12 - Building 2A modal analysis peak moments when seismic forces act parallel to the X direction (E_x)

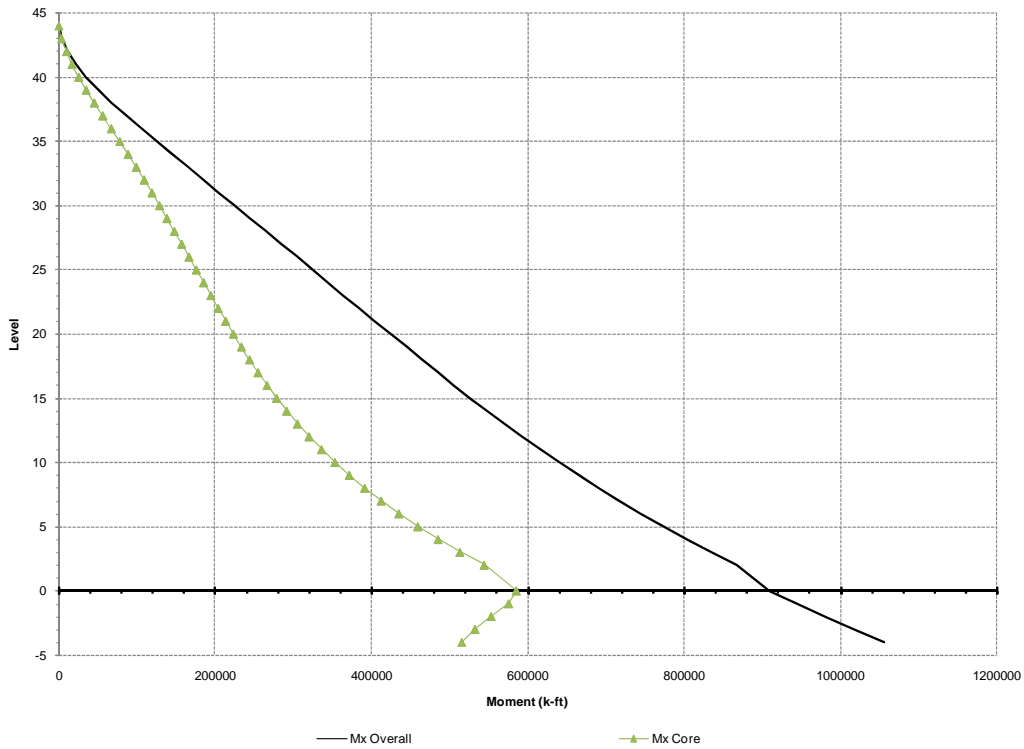

Figure 13 - Building 2A modal analysis peak moments when seismic forces act parallel to the Y direction (E_y)

3.2 Building 2A - Wind Design

Wind forces were calculated using section 6 of ASCE 7-05 (2006). Table 7 shows the parameters and resulting forces used for wind design.

Table 7 – Wind Design Parameters per ASCE 7-05 (2006)

Basic wind speed (V)	85 mph
Occupancy category	II
Surface roughness	B
Exposure type	B
Gust effect factor (G_f)	0.89
Enclosure classification	Enclosed
Topographic factor (K_z)	1
Percent of critical damping ration (β)	2.5 %
Wind shear at ground floor	1,345 kip
Wind overturning moment at ground floor	272,378 kip

Comparing the base shears and overturning moments from the wind and seismic design it can be concluded that the design is governed by the seismic forces.

4.0 Building 2B - Analysis Summary

Building 2B was designed and checked for the following two performance levels:

1. Serviceability level using an elastic ETABS (2008) model.
2. Collapse prevention level using a three-dimensional non-linear step by step time-history analysis with the program Perform 3D (2007)

For both models the stiffness is obtained from expected material properties and the modification factors given in Table 3.

The provisions for seismic design according to the LATBSDC (2008) recommendations are followed with the following exceptions.

- Service level check is for an earthquake event of 25 year return period with 2.5% viscous damping. Up to 20% of the elements with ductile action are allowed to reach 150% of their capacity under the serviceability check.
- The minimum base shear specified in the LATBSDC (2008) is waived.

Building 2B core wall properties are summarized in Table 8. Table 9 shows the periods obtained from both the serviceability and collapse prevention models using the stiffness assumptions from Table 3 and expected material properties.

Table 8 - Building 2B Specified Core Wall Thickness and Strength

Thickness	24" from foundation to 20 th 18" Above 20 th up to 30 th 16" Above 30 th
Specified concrete strength (f'_c)	8000 psi from foundation to 20 th 6000 psi from 20 th to 30 th 5000 psi Above 30 th
Expected concrete strength^A ($f'_{c_{exp}}$)	10400 psi from foundation to 20 th 7800 psi from 20 th to 30 th 6500 psi Above 30 th
Specified reinforcing strength (f_y)	60 ksi (A706)
Expected reinforcing strength^B ($f_{y_{exp}}$)	70 ksi

A. f'_c expected equals 1.3 times specified f'_c

B. f_y expected equals 1.17 times specified f_y

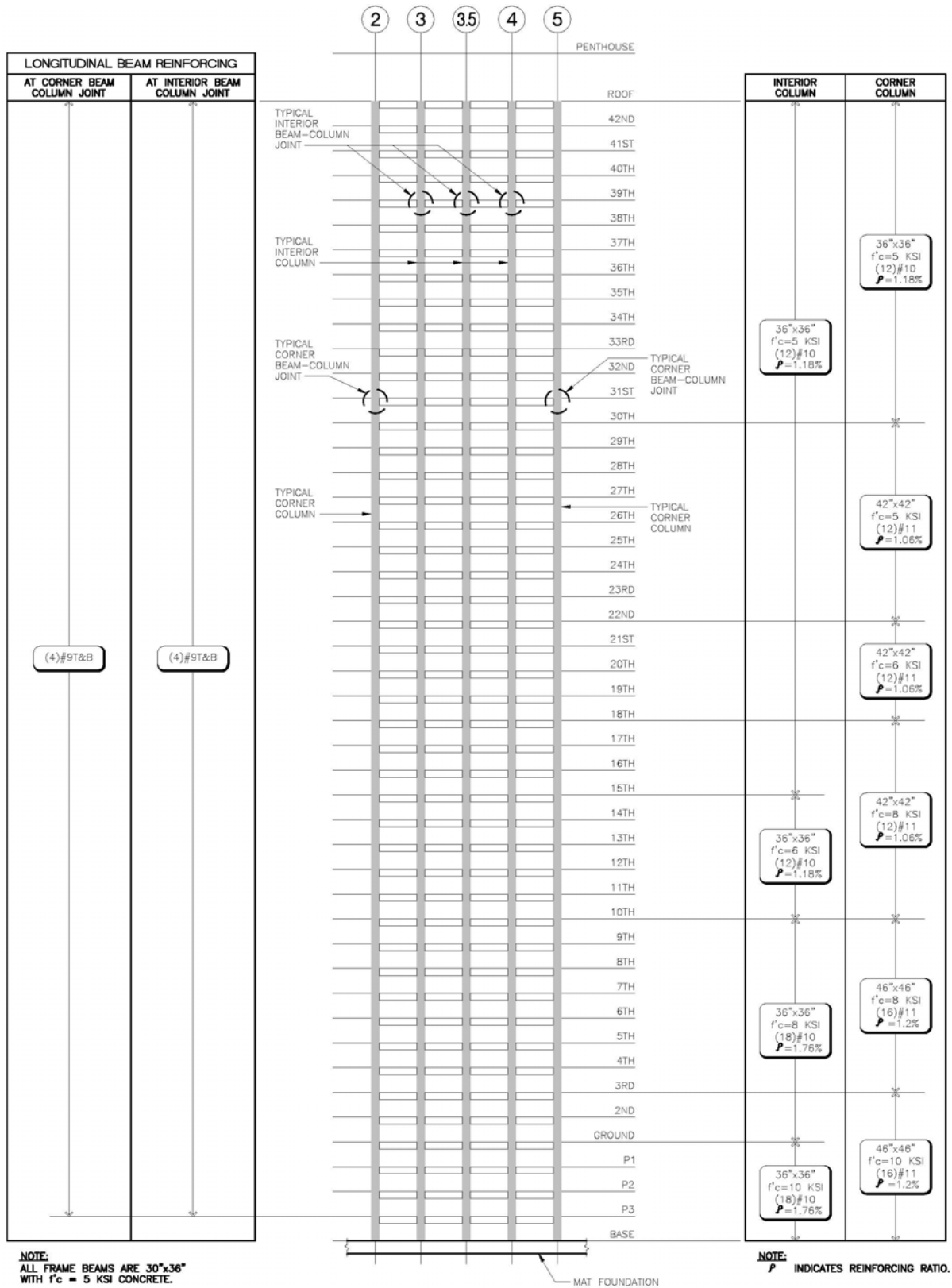

Figure 14 - Elevation and properties of frames A and F for building 2B

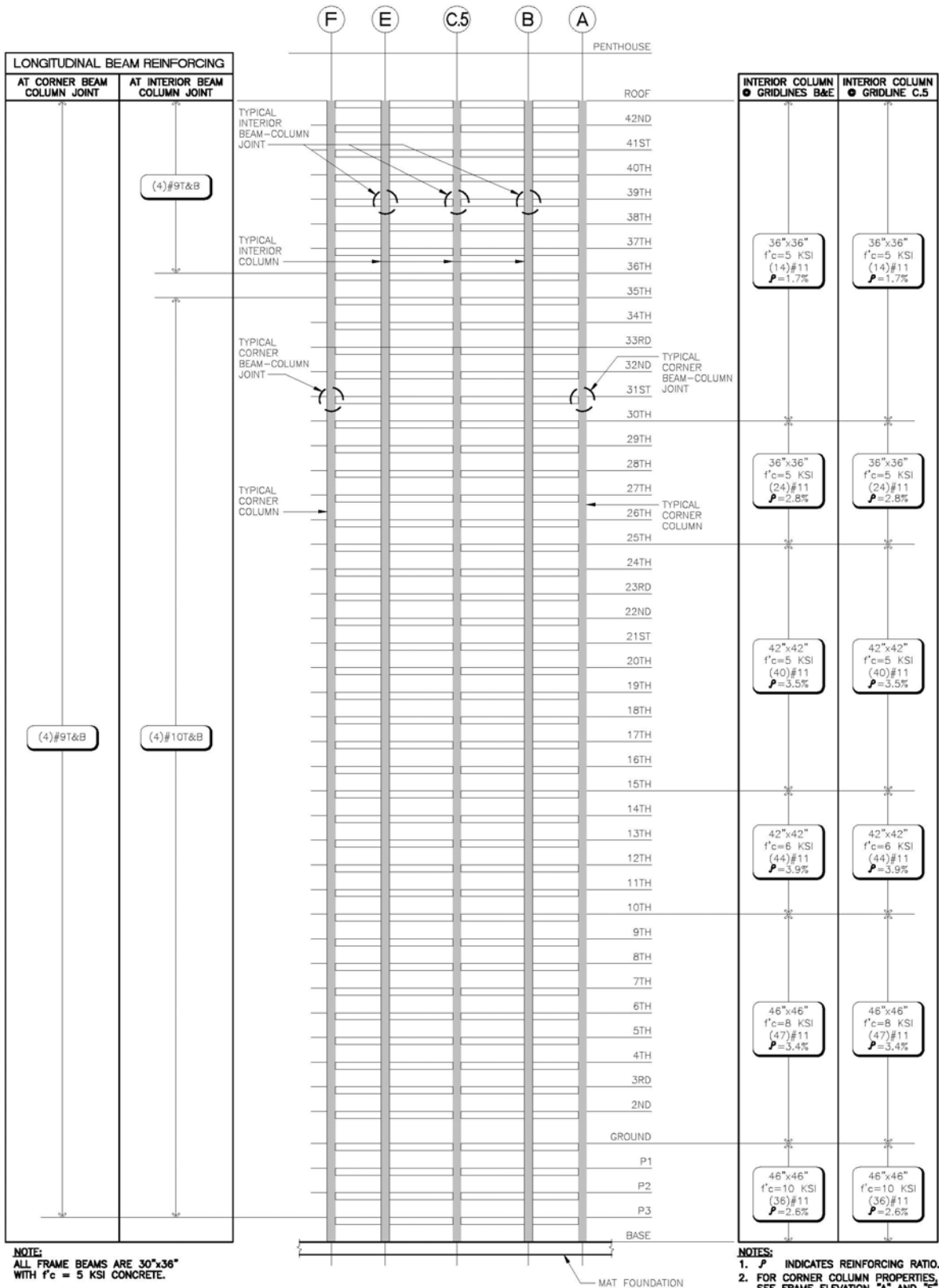

Figure 15 - Elevation and properties of frames 2 and 5 for building 2B

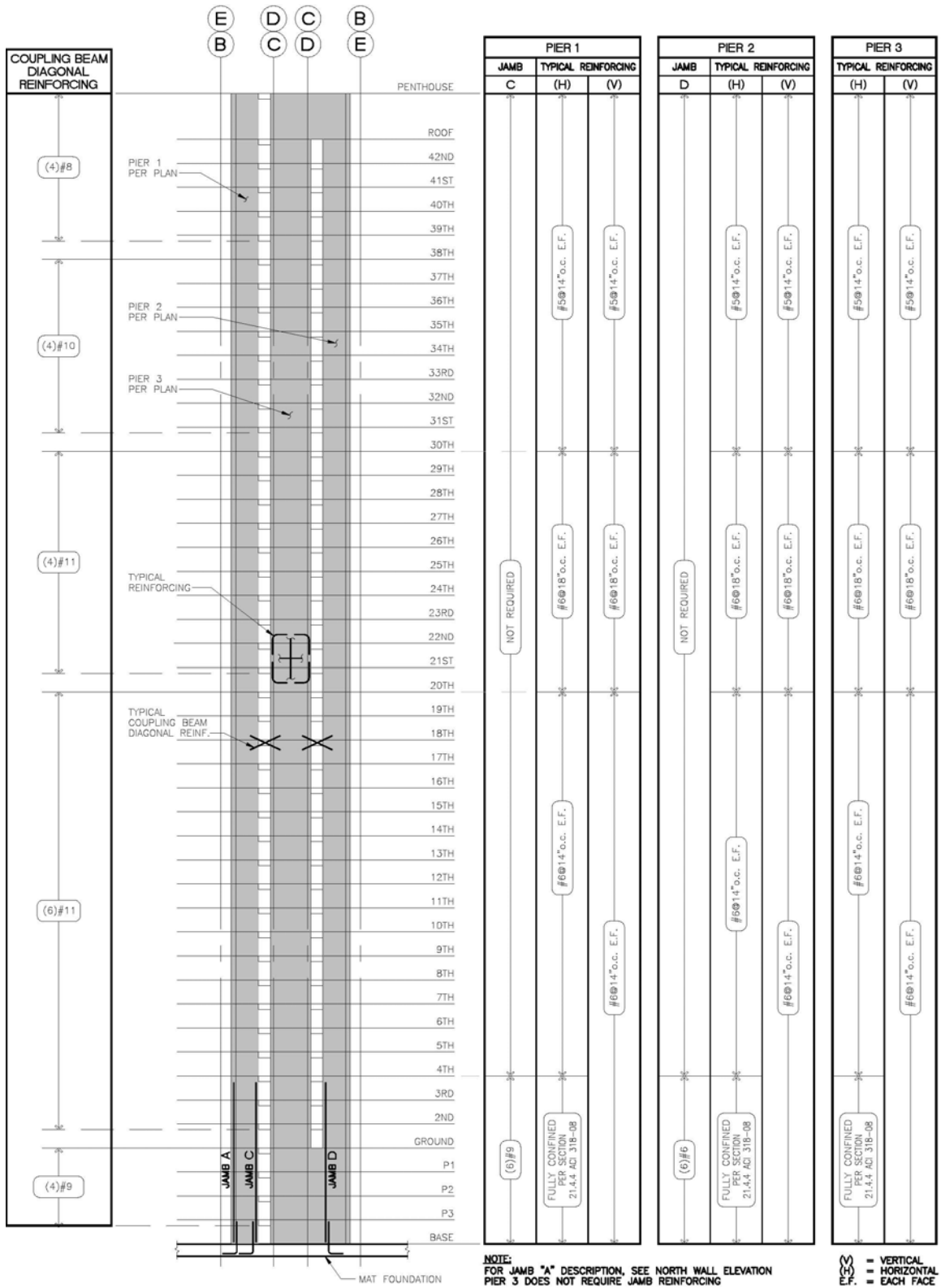

Figure 16 - Elevation A and shear wall reinforcing for building 2B

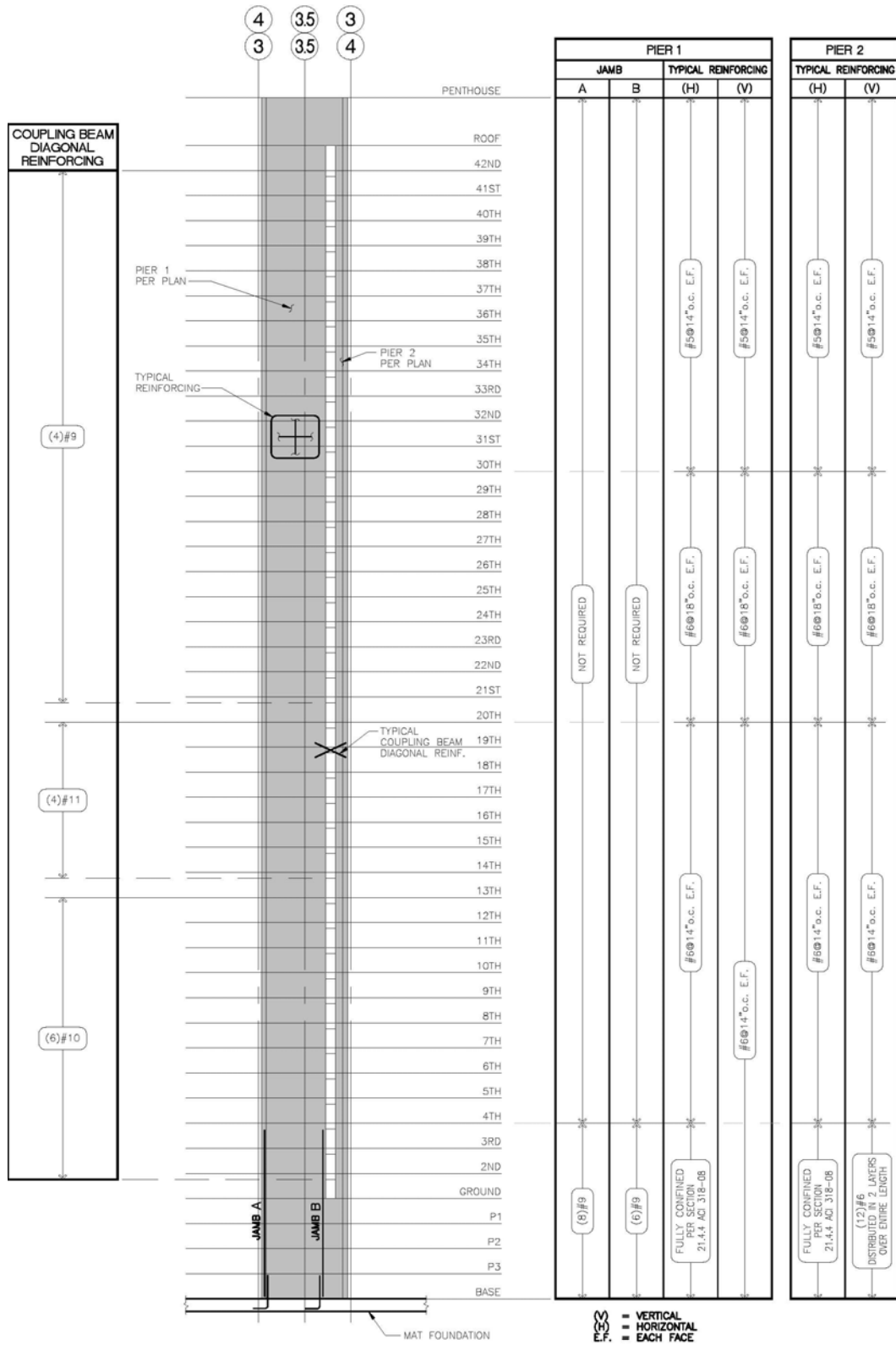

Figure 17 - Elevation B and shear wall reinforcing for building 2B

The periods obtained by the program Perform 3D (2007) from the model used for collapse prevention are obtained before the non-linear analyses are performed. The frame beams, columns and coupling beams reflect a reduced stiffness as described in the stiffness assumption table when calculating the period, however, the core shear walls are modeled using the uncracked properties of concrete. When the non-linear analyses are run, the stiffness of the core shear walls is adjusted according to its strain profile. The periods obtained by the program ETABS (2008) reflect the stiffness of elements modified per Table 3. Table 9 shows a summary of the periods obtained for building 2B.

Table 9 – Building 2B Period Summary from the Computer Models Used to Check Serviceability and Collapse Prevention Performance Levels

Vibration Mode	Period			Dominant direction
	At service level	At collapse prevention level		
	ETABS	Perform 3D	ETABS	
1	4.01 sec.	4.28 sec.	4.93 sec.	Translation mode on X direction
2	3.53 sec.	3.87 sec.	4.50 sec.	Translation mode on Y direction
3	2.12 sec.	2.26 sec.	2.78 sec.	Torsional mode

4.1 Serviceability Analysis Seismic Force Determination

The design forces are obtained using an elastic site-specific response spectrum analysis where the spectrum represents a mean recurrence interval of 25 years. This spectrum is shown in Figure 18. The stiffness assumptions used are those summarized in Table 3.

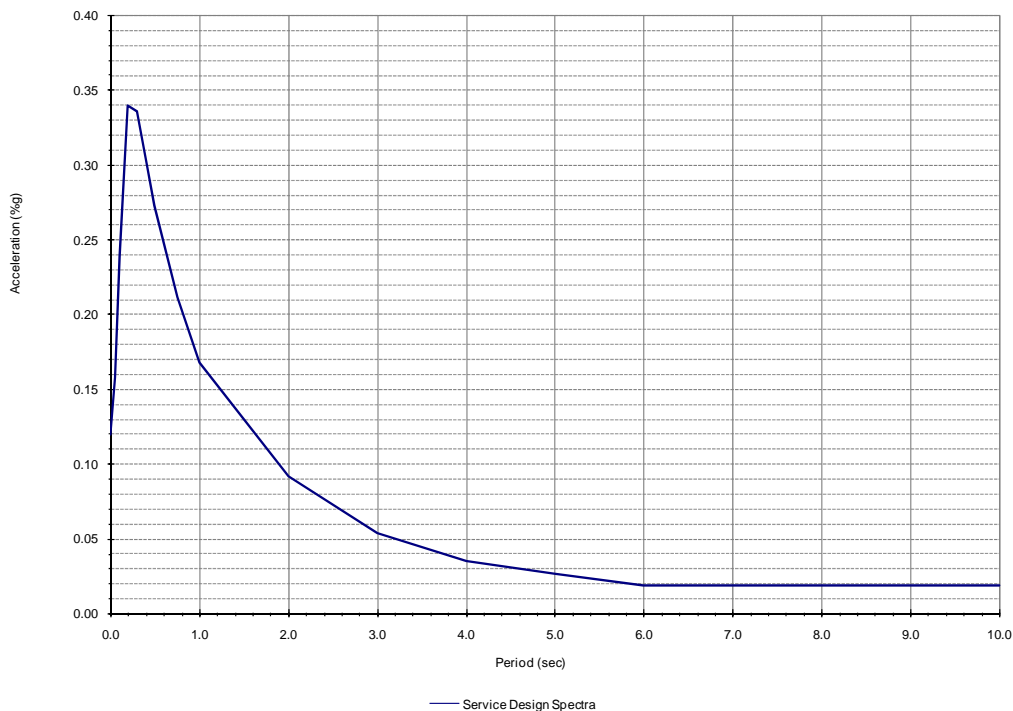

Figure 18 – 2.5% Damped service level site specific response spectra

Accidental eccentricity is not considered for serviceability checks per Section 3.3.5 of the LATBSDC (2008) document.

4.1.1 Service Level Design Acceptance Criteria

Building 2B is checked for the load combinations using dead load, live load and wind load as described in IBC 2006 calculating the strength of each element as described in the same document.

For the seismic design, the load combination used is described by equation 1.

$$D_L + 0.25L_L \pm E_{\text{service}} \quad \text{Eq. - 1}$$

D_L and L_L are the dead and live loads, respectively, and E_{service} refers to the earthquake demand at service level. The live load is not reduced. $0.25L_L$ is also referred to as the expected live load.

Orthogonal load combinations for earthquake loads are applied as required per Section 12.5 of ASCE 7-05 (2006).

Per Section 3.3.6 of the LATBSDC (2008) document, the overall inter-story drift of the structure should not exceed $0.005 h_n$.

When checking against the load combination shown in Equation 1, 20% of the elements with ductile actions are allowed to have a demand to capacity ratio between 1.0 and 1.5. The remainder of elements should have a demand to capacity ratio of 1.0 or less. All elements with brittle actions should have a demand capacity ratio of 1.0 or less. For both ductile and brittle actions, strengths should be calculated using a strength reduction factor in accordance with current material codes. For brittle actions, strength is calculated using specified material properties. For ductile actions expected material properties are used. Figures 19 through 23 show the representative plots for service level design.

Table 10 – Design Acceptance Criteria for Service Level Design Earthquake

Element	Action type	Classification
Reinforced Concrete Frame Beam	Flexure Shear ^B	Ductile Brittle
Reinforced Concrete Frame Column	Axial-Flexure interaction ^C Shear ^B	Ductile Brittle
Reinforced Concrete Shear walls	Flexure ^C Shear ^B	Ductile Brittle
Reinforced concrete coupling beams	Shear ^D	Ductile

Notes:

- Care needs to be exercised when detailing elements for ductility. Refer to Paulay and Priestley (1992) or Englekirk (2003) for a detailed discussion on detailing reinforced concrete elements for ductility.
- Shear design for shear walls, frame beams and columns should be done using capacity design procedures as described by Paulay and Priestley (1992).
- To ensure that a column or a shear wall is ductile in flexure, the maximum axial compression should be limited as described in the acceptability criteria for collapse prevention.
- It is important to note that when detailed per ACI 318 (2008), coupling beams behave in a ductile manner as shown by Naish et al (2009).

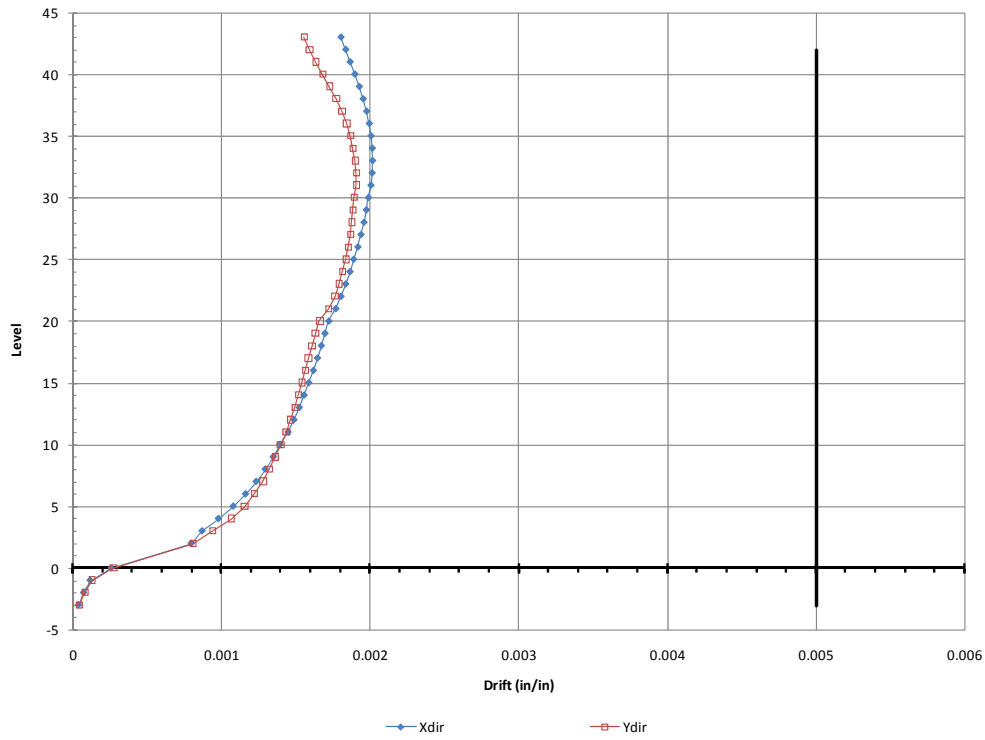

Figure 19 - Building 2B peak inter-story drifts at service level from seismic forces on X and Y directions

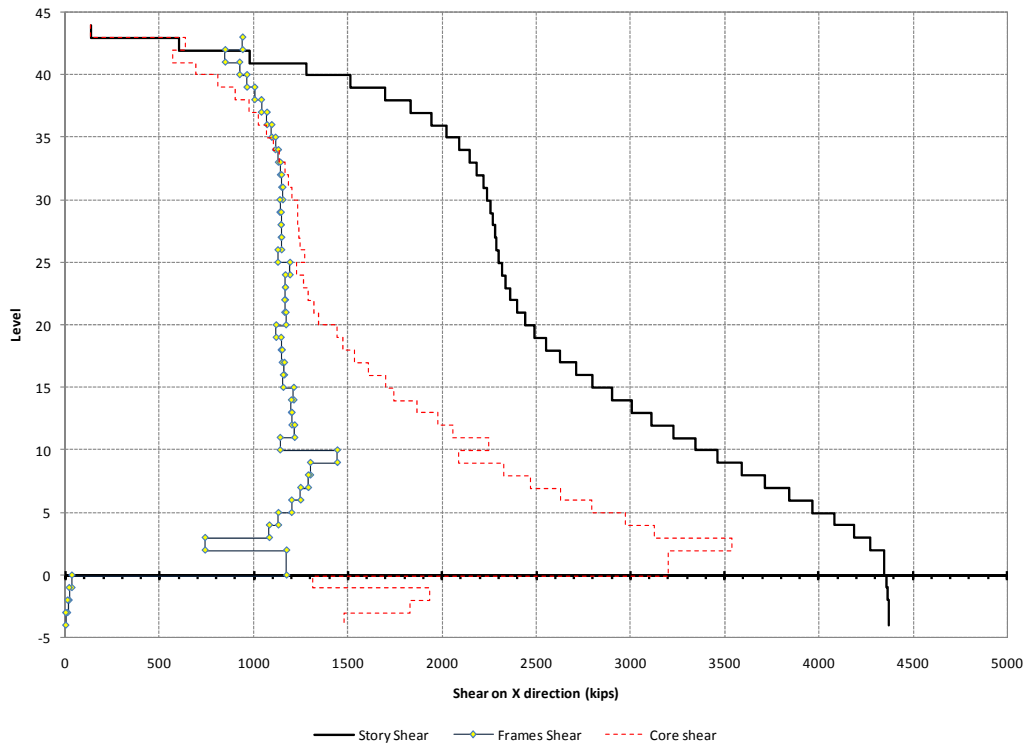

Figure 20 - Building 2B modal analysis peak shear at service level from seismic forces on X direction

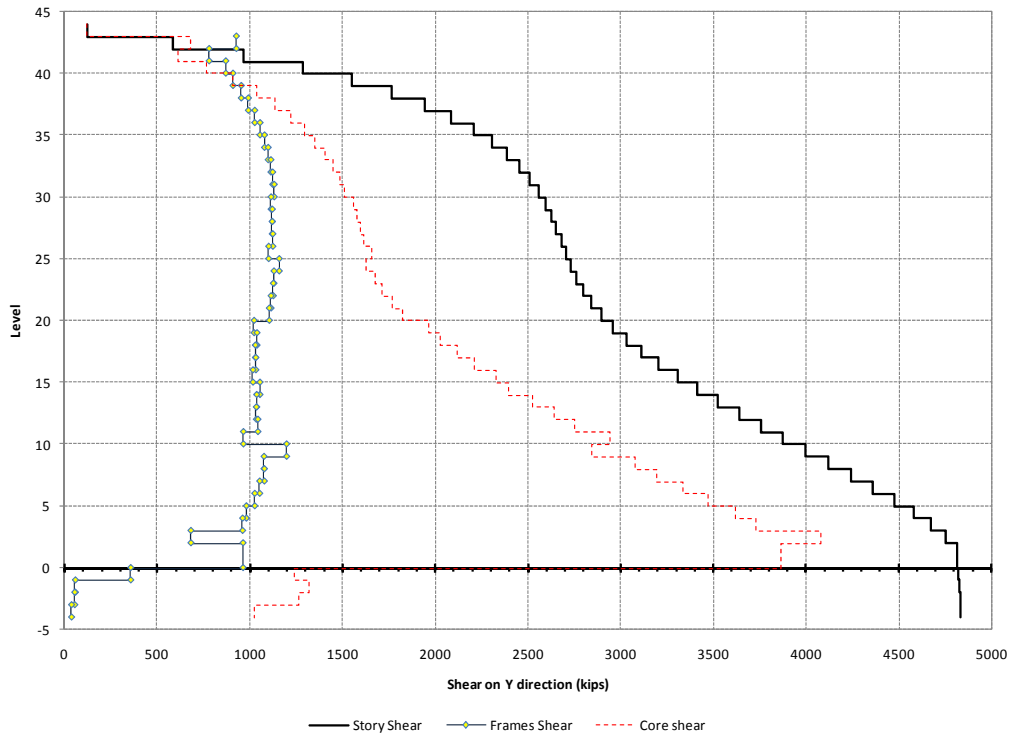

Figure 21 - Building 2B modal analysis peak shear at service level from seismic forces on Y direction

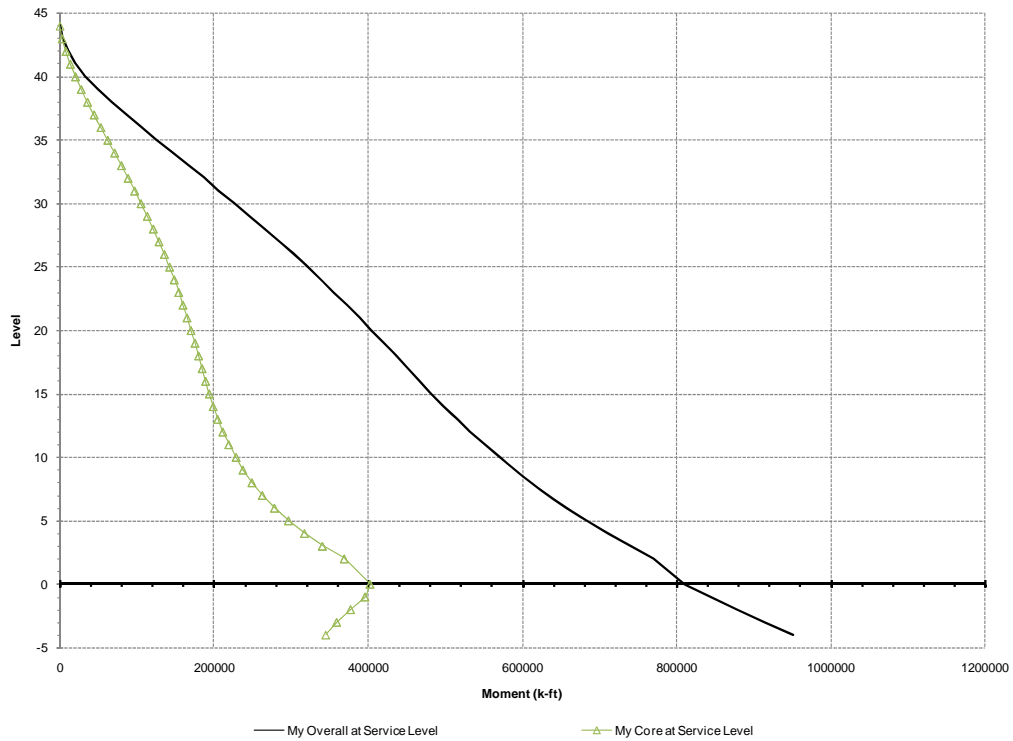

Figure 22 - Building 2B modal analysis peak moments at service level when seismic forces are parallel to the X direction (E_x)

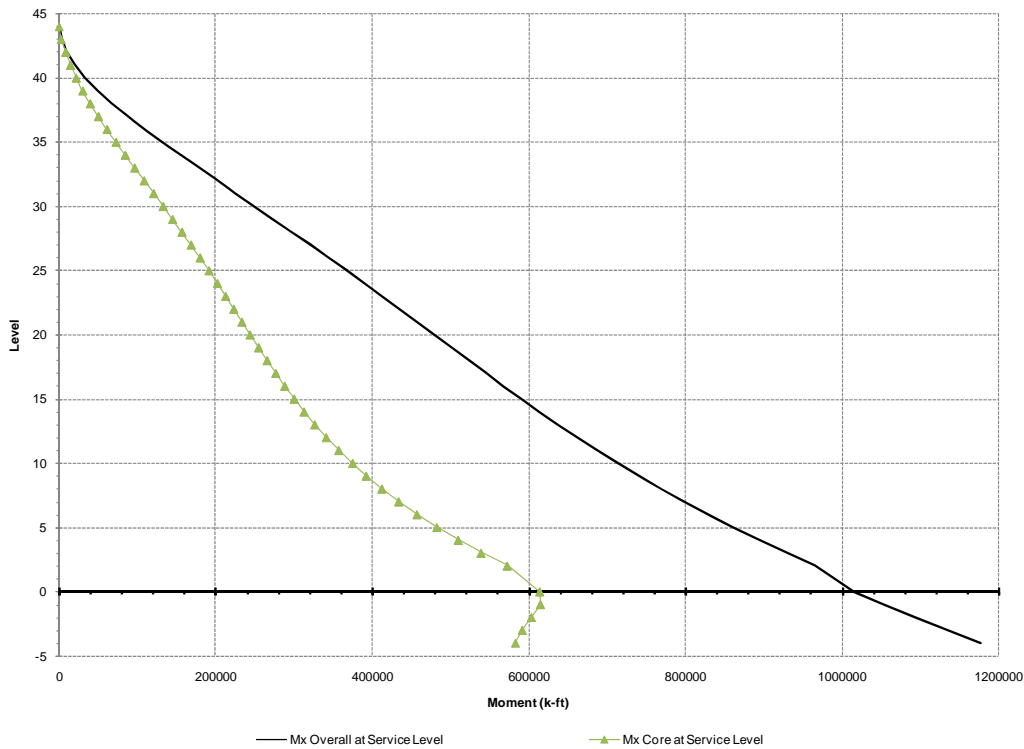

Figure 23 - Building 2B modal analysis peak moments at service level when seismic forces are parallel to the Y direction (E_y)

4.2 Collapse Prevention Step by Step Non-linear Analysis

Seven pairs of spectrally matched ground motions were used to represent the MCE with a mean recurrence interval of 2475 years (2% probability of exceedance in 50 years).

A model was built in Perform 3D (2007) to represent the lateral system of the building. The seismic mass equivalent to the dead load and its associated rotational moment of inertia is assigned at levels above the ground floor. The mass associated to the ground level and below is ignored.

The core walls and moment frames extend down to the foundation level. The diaphragms at the ground floor and below are modeled with a finite element mesh to account for their in-plane stiffness modified per Table 3. The diaphragms above ground level are modeled as rigid diaphragms by slaving the horizontal translation degrees of freedom. Ground motions are input at the top of the mat foundation. The foundation is idealized as rigid by providing lateral and vertical supports at the top of the foundation. The lateral resistance of the soil surrounding the subterranean walls is neglected.

Per LATBSDC (2008), if during the serviceability evaluation the factor A_x as described in ASCE 7-05 (2006) is greater than 1.5, accidental eccentricity should be considered during collapse prevention analysis. Because the building being studied is regular in plan and elevation, the factor A_x is always less than 1.5.

P-Delta effects are considered in the model by the inclusion of a “*P-Delta Column*” at the center of mass of the building with an axial load equivalent to the dead load plus the expected live load. This column is pinned at both ends on each level with its nodes slaved to the diaphragm defined at each floor.

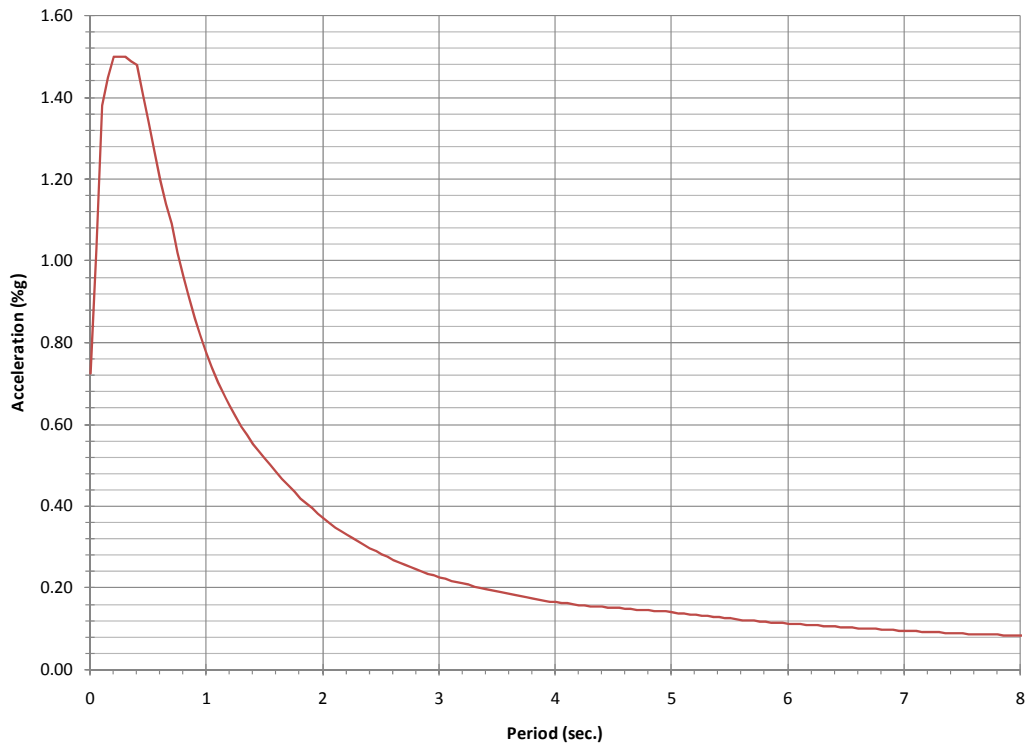

Figure 24 – Target acceleration response spectra at MCE level.

4.2.1 Collapse Prevention Acceptance Criteria

To prevent collapse at the MCE level of forces, the acceptance criteria shown in Table 11 should be met.

For actions classified as ductile, the strength should be calculated using expected material properties and a strength reduction factor of 1.

For actions classified as brittle, the strength should be calculated using specified material properties and a strength reduction factor of 1. This capacity should exceed the smaller of the average demand from the seven time-history records times 1.5 or the maximum force that the structural system can deliver.

In order to achieve ductile behavior a plastic mechanism as described in the SEAOC Blue Book (2008) should be observed in the frames. Care needs to be exercised when detailing elements for ductility. Paulay and Priestley (1992) and Englekirk (2003) give an in-depth discussion on how to detail reinforced concrete elements to achieve ductile behavior. ACI 318 (2008) provides guidelines to detail coupling beams to sustain the allowed displacement demands as shown by Wallace (2007).

Table 11 – Collapse Prevention Non-Linear Model Acceptance Criteria

Element	Action type	Classification	Expected behavior	Acceptance limit for non-linear behavior
Reinforced Concrete Frame Beam	Plastic hinge rotation Beam Shear	Ductile Brittle	Non-linear Linear	Hinge rotation ≤ 0.045 rad N.A.
Reinforced Concrete Frame Column	Axial-Flexure interaction	Ductile	Non-linear	Axial compression $\leq 0.40 f'_{c_{exp}} A_g$ Hinge rotation ≤ 0.025 rad
	Shear	Brittle	Linear	N.A.
Reinforced Concrete Shear walls	Axial-Flexure interaction	Ductile	Non-linear	Concrete compression strain ≤ 0.015 Reinforcing rebar tension strain ≤ 0.05 Axial compression force $\leq 0.35 f'_{c} A_g$
	Shear	Brittle	Linear	N.A.
Reinforced concrete coupling beams	Shear	Ductile	Non-linear	0.06 rad chord rotation

N.A. Not applicable

4.2.2 Core Wall Modeling Properties

The core walls are modeled using non-linear vertical fiber elements representing the expected behavior of the concrete and reinforcing steel. The shear behavior is modeled as elastic.

The concrete stress-strain relationship is based on the modified Mander model for confined concrete (Mander et al., 1988) with a confining ratio as required per ACI 318 (2008), Section 21.4.4. The tension strength of concrete is neglected.

For the fiber elements, all concrete is defined as confined. The wall thickness used to calculate the flexural and shear stiffness of the wall section corresponds to the confined thickness in anticipation of spalling. If in the MCE time history non-linear analysis the average concrete compression strain exceeds 0.002, confinement is provided.

In order to match the curve defined by the modified Mander model (Mander et al., 1998), the initial elastic stiffness used to model the concrete material for the fiber sections differs from that calculated by the equations given in ACI 318 (2008) and ACI 363 (1992). Figure 25 shows the curve defined by the modified Mander model (Mander et al., 1998) and the values that were used to model the stress-strain curve of concrete with specified strength (f'_c) of 8 ksi in Perform 3D (2007).

Table 12 shows a comparison of the elastic modulus calculated per ACI 318 (2008) and ACI 363 (1992) using specified material properties, the same elastic modulus using expected material properties and the elastic modulus used in the non-linear model adjusted to match the modified Mander model (Mander et al., 1998). Figures 26 and 27 show the Perform 3D (2007) screen shots used to define the concrete material for shear walls with a specified strength of 8 ksi.

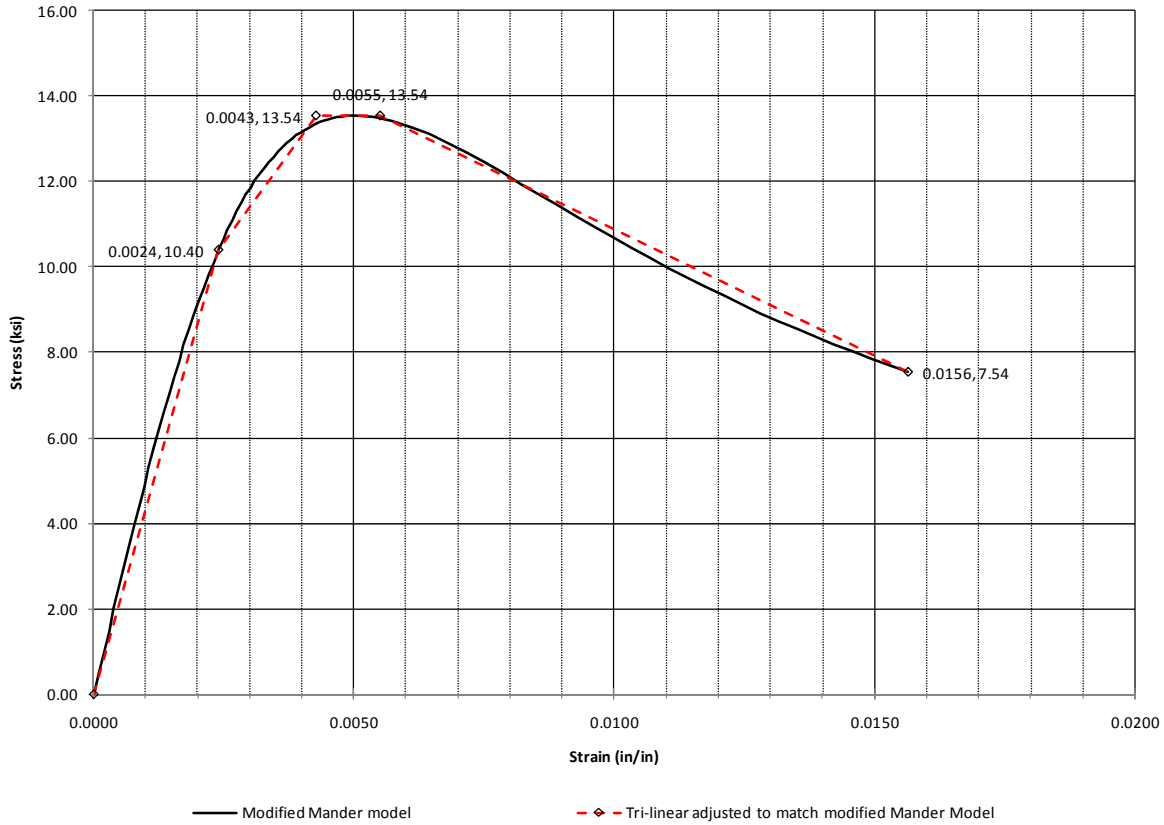

Figure 25 – Expected stress – strain curve for confined concrete with specified concrete strength (f'_c) of 8 ksi

The steel stress-strain relationship is based on the material specifications for A706 reinforcing steel. The steel material is modeled with a tri-linear stress-strain relationship with expected yield strength ($f_{y, \text{expected}}$) of 70 ksi and an ultimate strength of 105 ksi in both compression and tension.

The post-yield stiffness and cyclic degradation of reinforcing steel has been adjusted by modeling in Perform 3D (2007) the rectangular wall described by Orakcal et al. (2006) and adjusting it to match the lateral load vs. top displacement curve. The parameters used to define the reinforcing steel are shown in Figures 28 and 29.

Table 12 – Concrete Elastic Modulus Comparison

f'_c	E_c Per ACI 318 (2008) and ACI 363 (1992)	E_c expected (1.14 x E_c)	Initial elastic stiffness for non-linear model
(ksi)	(ksi)	(ksi)	(ksi)
5	4031	4595	3229
6	4098	4671	3597
8	4578	5219	4340
10	5000	5700	4941

$E_c = 57000 \sqrt{f'_c}$; for $f'_c < 6$ ksi per ACI 318 (2008)

$E_c = 40000 \sqrt{f'_c} + 1 \times 10^6$; for $f'_c \geq 6$ ksi per ACI 363 (1992)

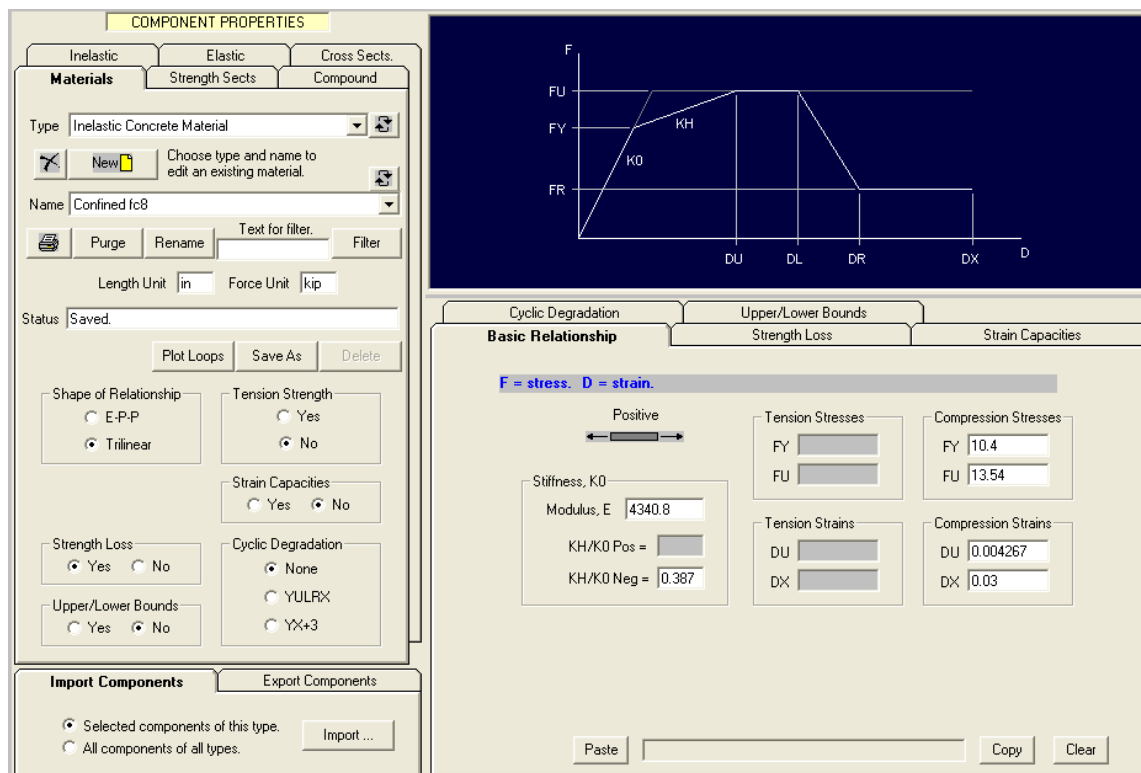

Figure 26 – Inelastic concrete material screen shot from Perform 3D (2007)

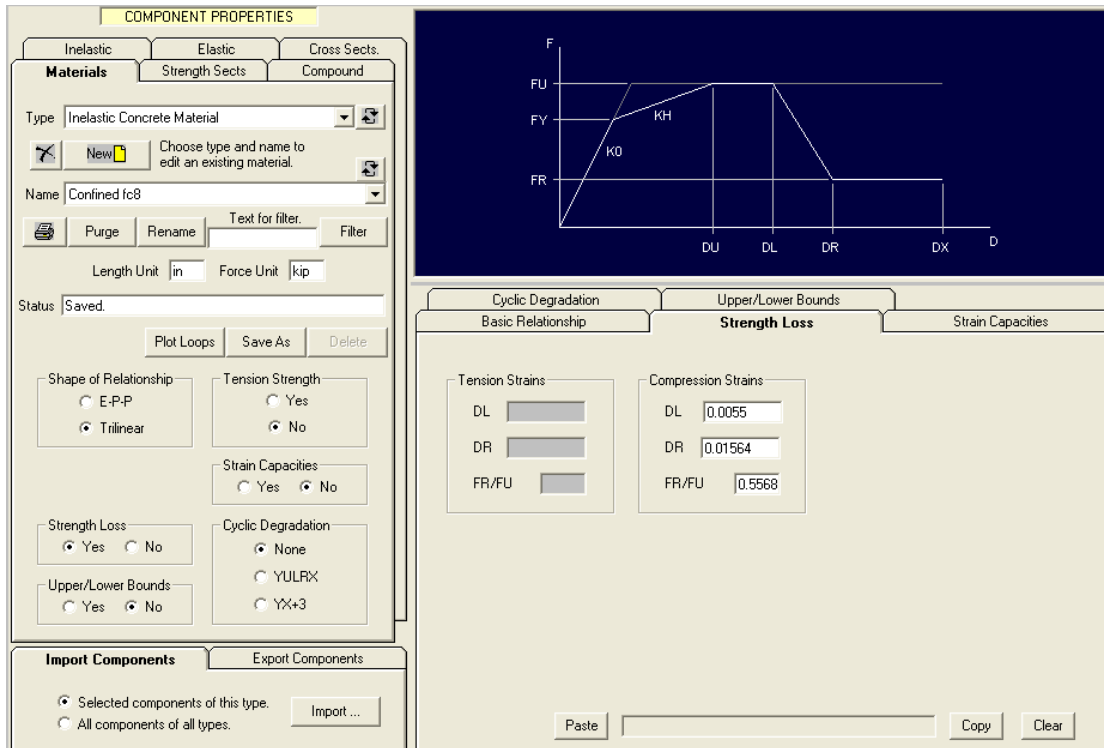

Figure 27 - Inelastic concrete material screen shot from Perform 3D (2007)

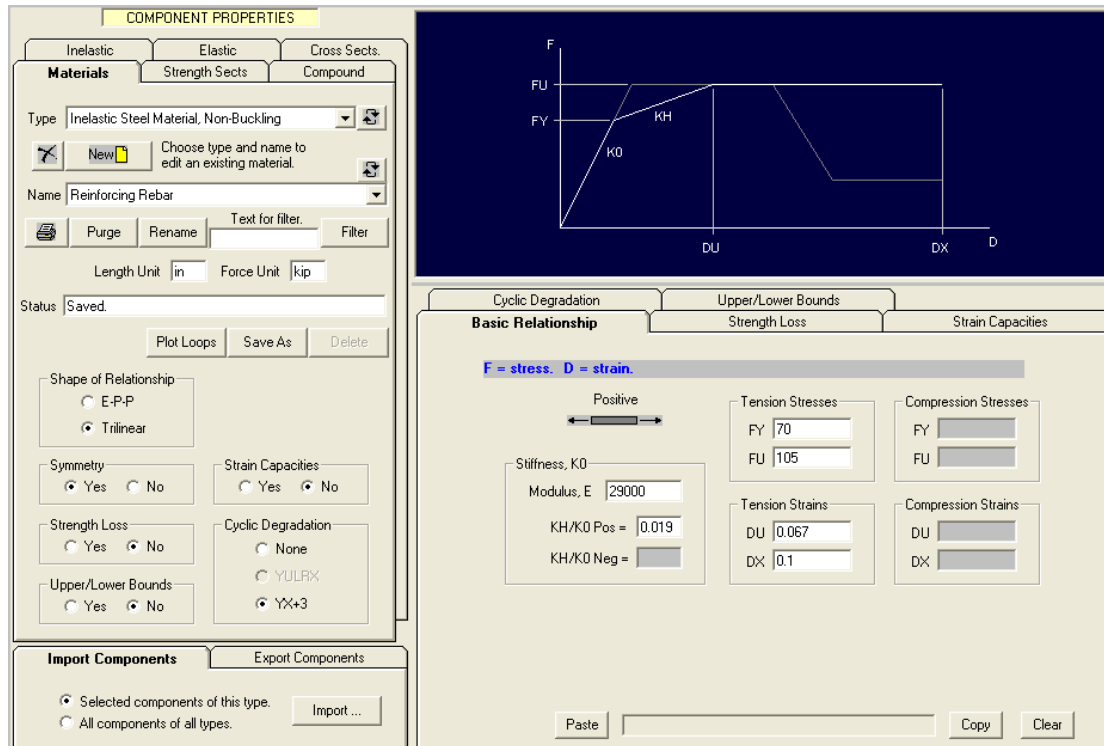

Figure 28 – Inelastic reinforcing rebar material screen shot from Perform 3D (2007)

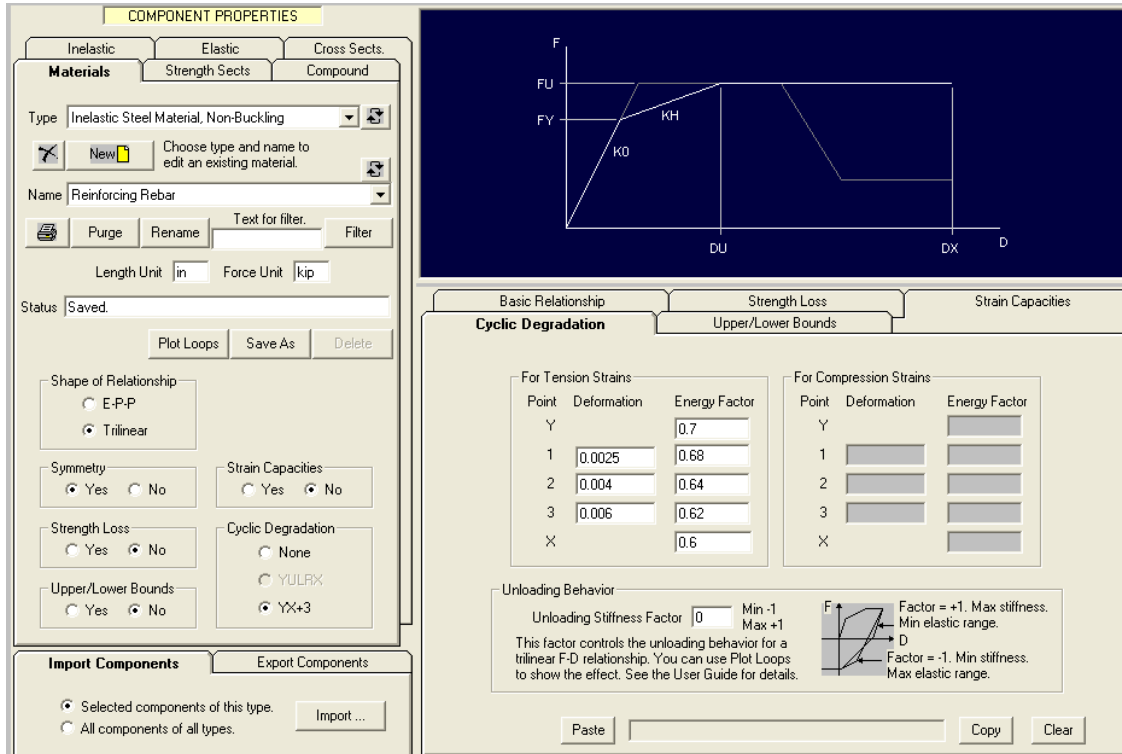

Figure 29 – Inelastic reinforcing rebar material screen shot from Perform 3D (2007)

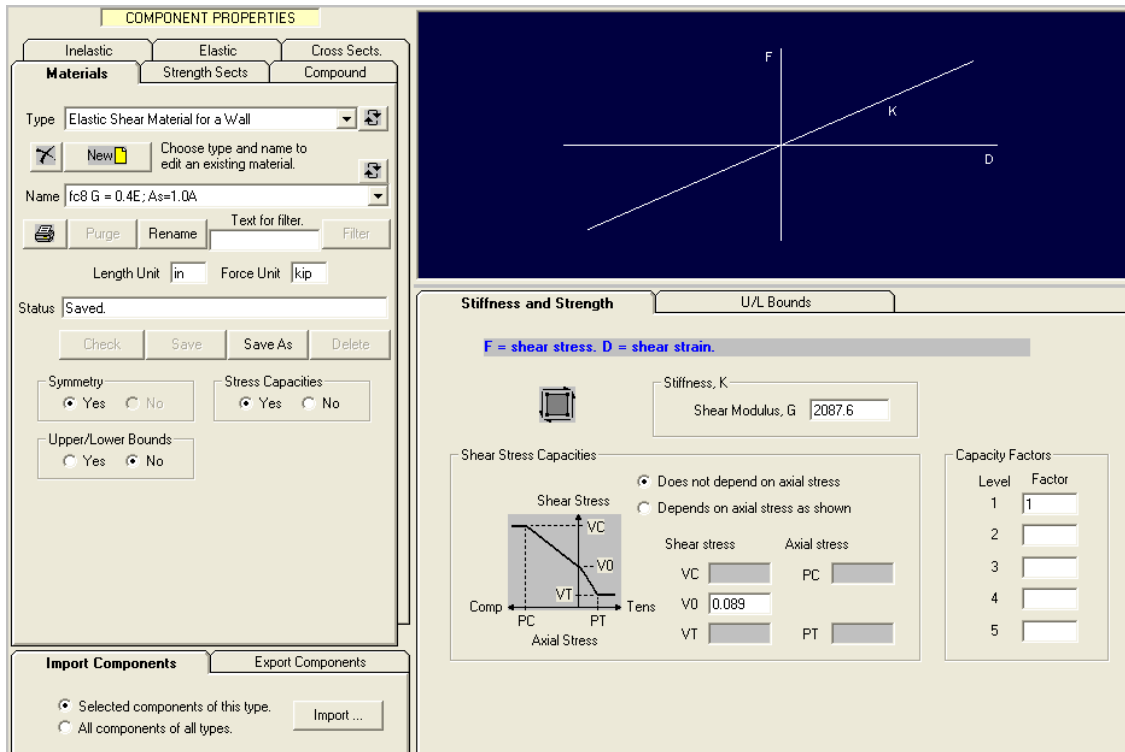

Figure 30 – Shear wall elastic shear material screen shot from Perform 3D (2007)

Figure 31 shows the cross section used to define a 24 in. wall with minimum reinforcing. As mentioned previously, the thickness is taken as 22 in. to account for concrete spalling. The reinforcing ratio is calculated per Equation 2. Figure 32 shows the compound element that defines a 24 in. shear wall with a reinforcing ratio of 0.0025 and specified concrete strength (f'_c) of 8 ksi.

$$\rho = 0.0025 \times 24'' / 22'' = 0.00272 \quad \text{Eq-2}$$

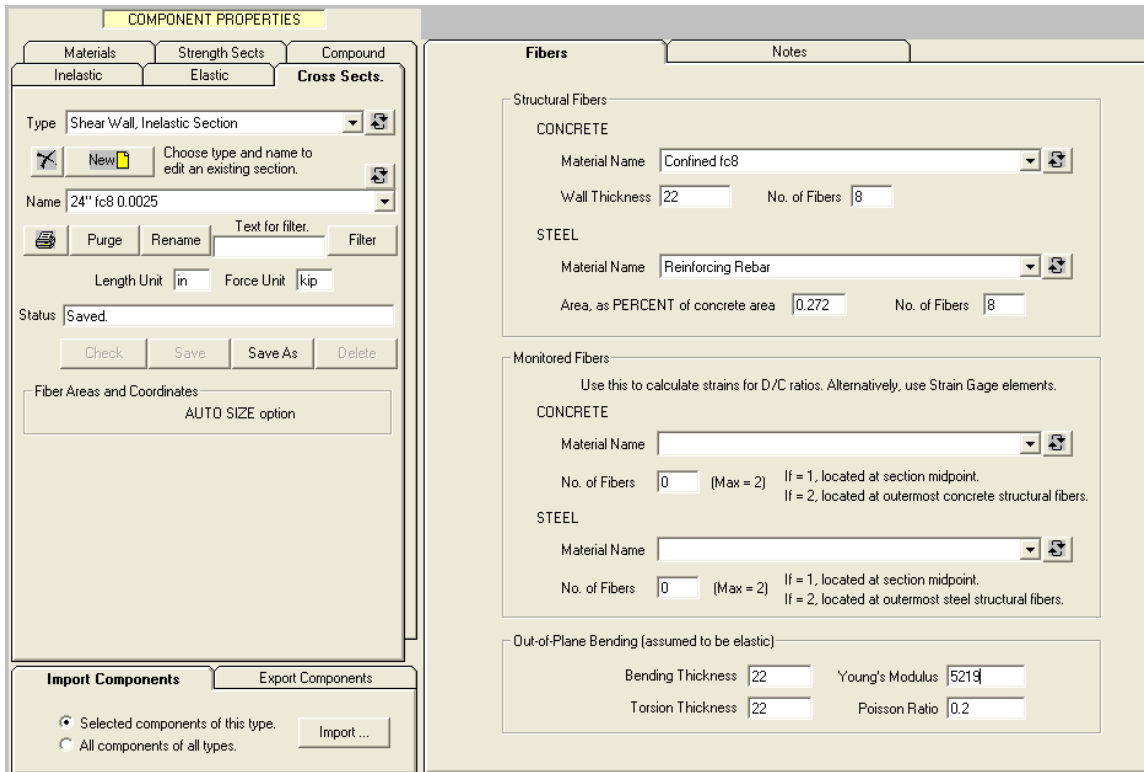

Figure 31 – Fiber wall cross-section screen shot from Perform 3D (2007)

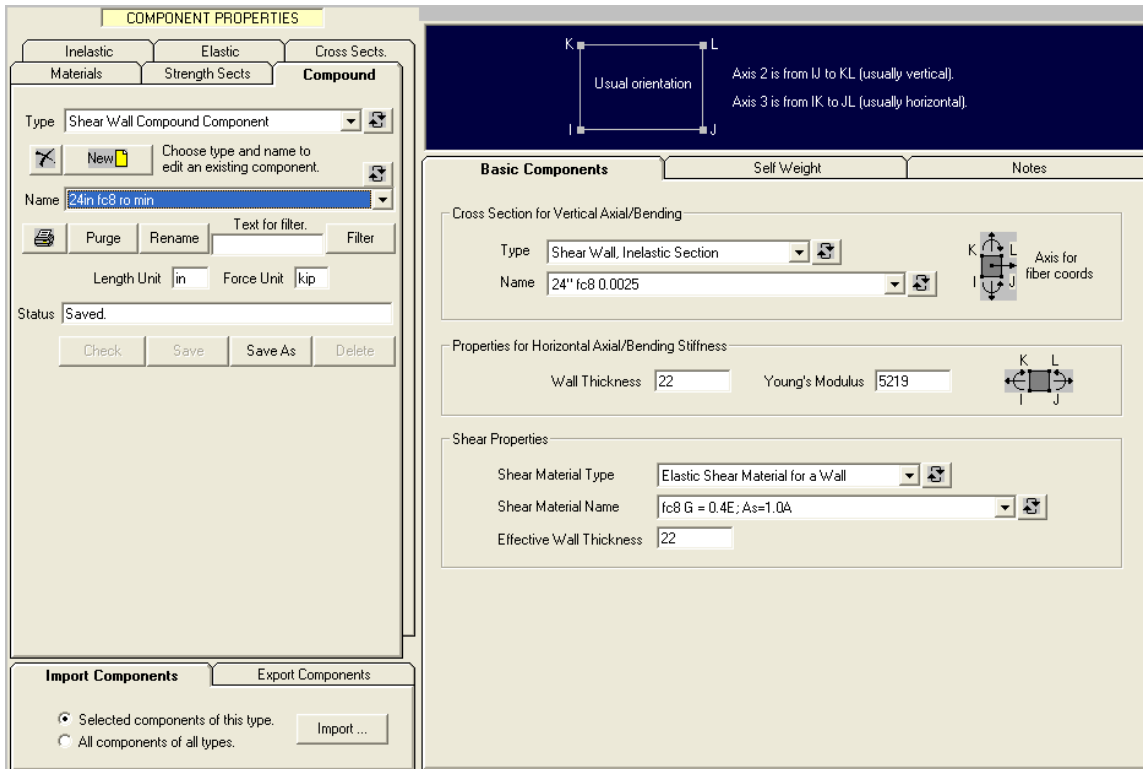

Figure 32 – Shear wall compound component screen shot from Perform 3D (2007)

4.2.3 Coupling Beam Modeling Properties

The coupling beams are defined as elastic beam elements with a nonlinear displacement shear hinge at the mid-span of the beam. These are connected to the shear walls using embedded elements as suggested by Powell (2007). The shear hinge behavior is based on test results by Naish et al. (2009).

To obtain the nominal expected shear capacity, the angle of the diagonals (α) is calculated using a distance from the center of gravity of the diagonal reinforcing to the face of the beam of 5 in. when the diagonal reinforcing consists of two layers of rebar and 7 in. when it consists of 3 layers of rebar. Figure 33 shows a sketch of the coupling beam diagonal reinforcing.

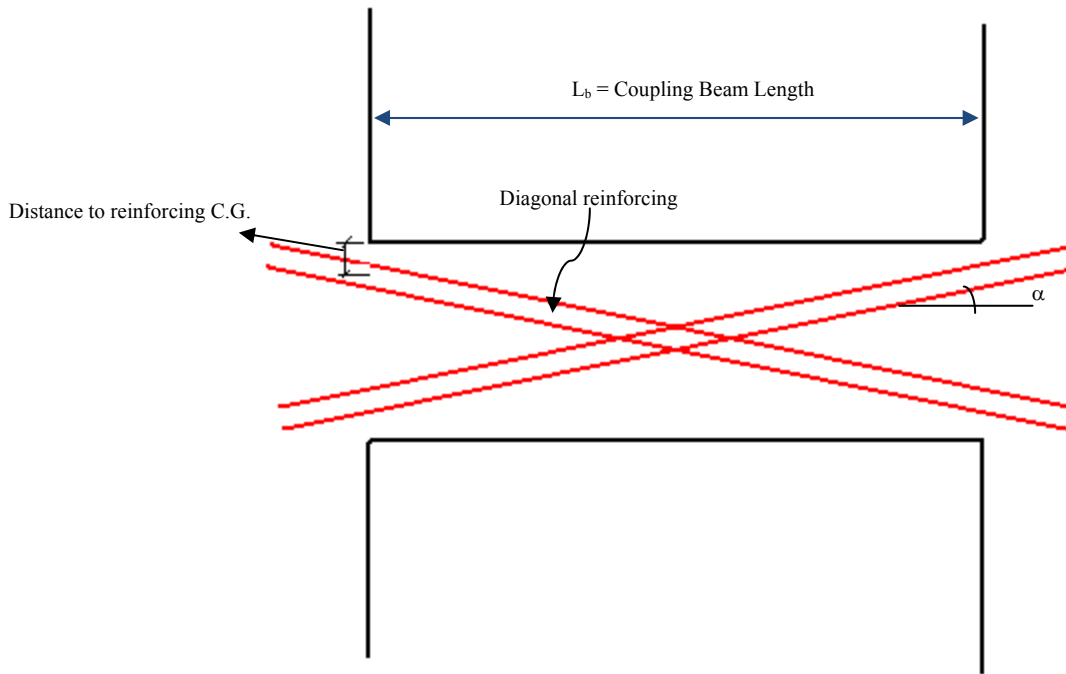

Figure 33 – Coupling beam diagonal reinforcing sketch

To define the behavior of the displacement shear hinge, the displacement is related to the rotation of the coupling beam as described in Equation 3.

$$\delta_{\theta} = \theta \times L_b \qquad \text{Eq. - 3}$$

Where θ is the rotation in radians, L_b is the length of the coupling beam and δ_{θ} is the equivalent displacement at a rotation θ . The following figures show the back bone parameters used to define the shear displacement hinges for coupling beams and screen shots from Perform 3D (2007) for a typical coupling beam.

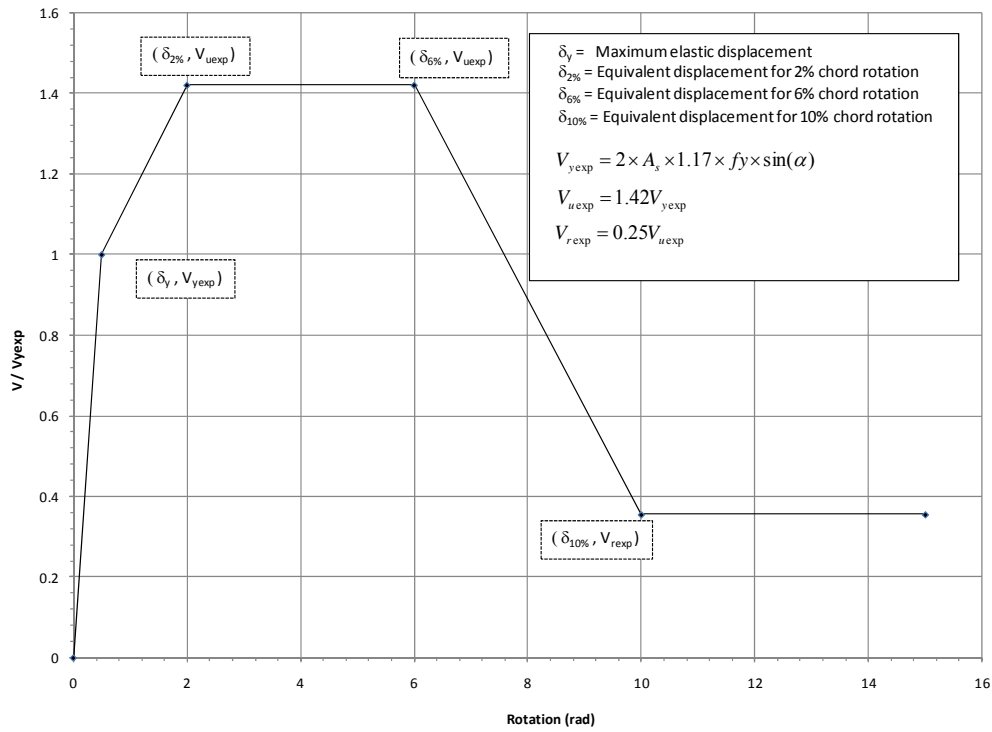

Figure 34 – Shear displacement hinge backbone curve

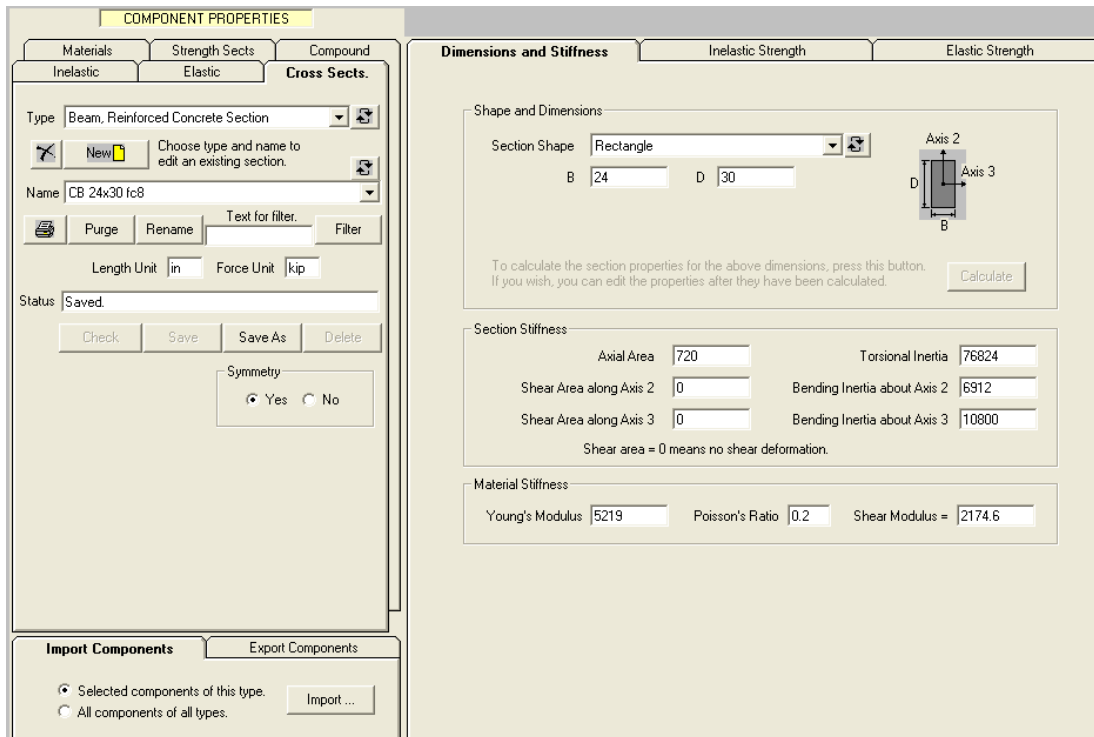

Figure 35 – Coupling beam elastic segment screen shot from Perform 3D (2007)

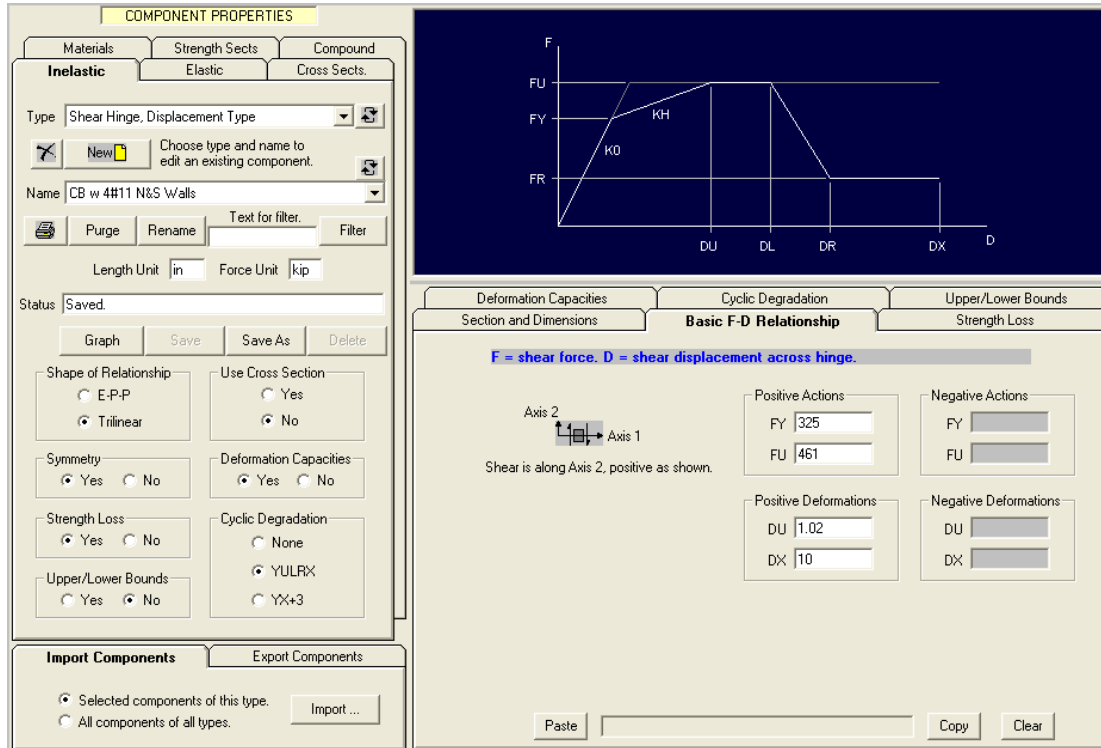

Figure 36 – Coupling beam displacement shear hinge screenshot from Perform 3D (2007)

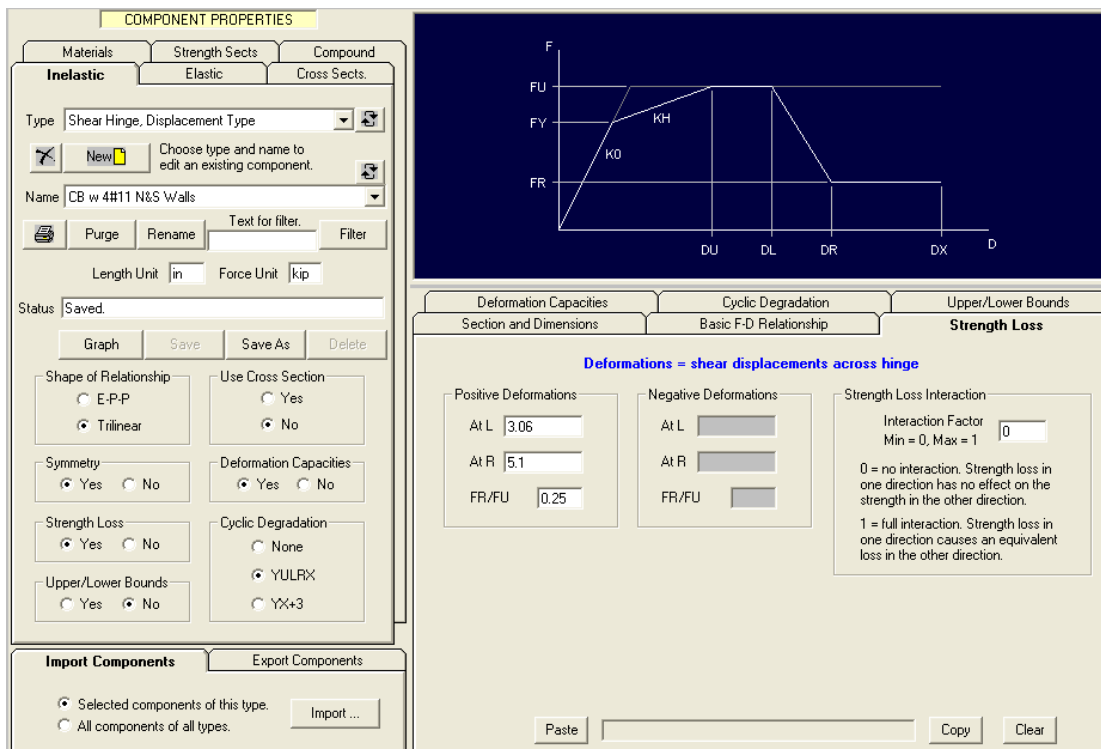

Figure 37 – Coupling beam displacement shear hinge screen shot from Perform 3D (2007)

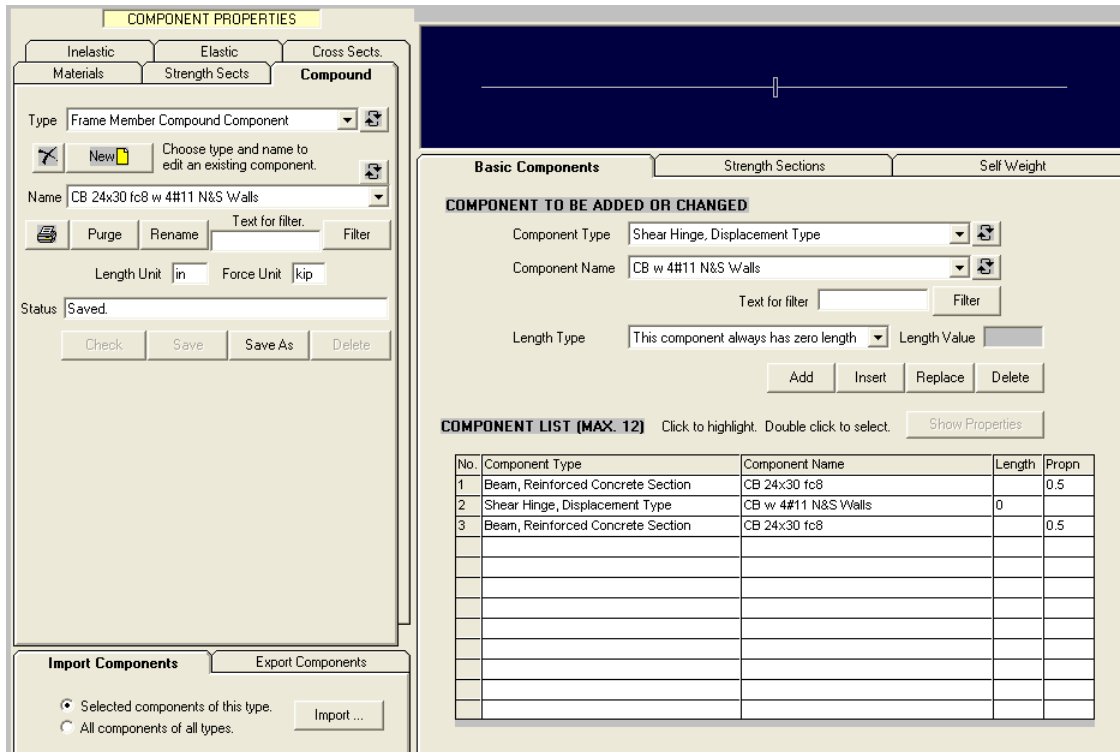

Figure 38 – Coupling beam compound component screen shot from Perform 3D (2007)

4.2.4 Moment Frame Beam Properties

The moment frame beams are defined as elastic beam elements with nonlinear rotation hinges and rigid end zones at each end. The rigid end zones extend from the column centerline to the face of the column, with a stiffness of 10 times the elastic stiffness of the beam.

Tests performed by Popov et al. (1972) are used to define the post-yield stiffness of the rotation hinges in beams. Figure 40 shows the setup that was used to perform these tests as described by Englekirk (2003). Figure 41 shows the force displacement relationship for this beam.

Using a plastic hinge length of half the beam depth, the ultimate beam plastic rotation is 0.046 radians. Strength degradation is not accounted for given that the acceptable rotation for the plastic hinge is lower than that associated with this effect.

To define the post-yield stiffness, a ratio of 1.18 is observed between the strength at ultimate and at yield. Using these values, Figure 39 shows the backbone curve used to define the behavior of beam rotation plastic hinges in Perform 3D (2007).

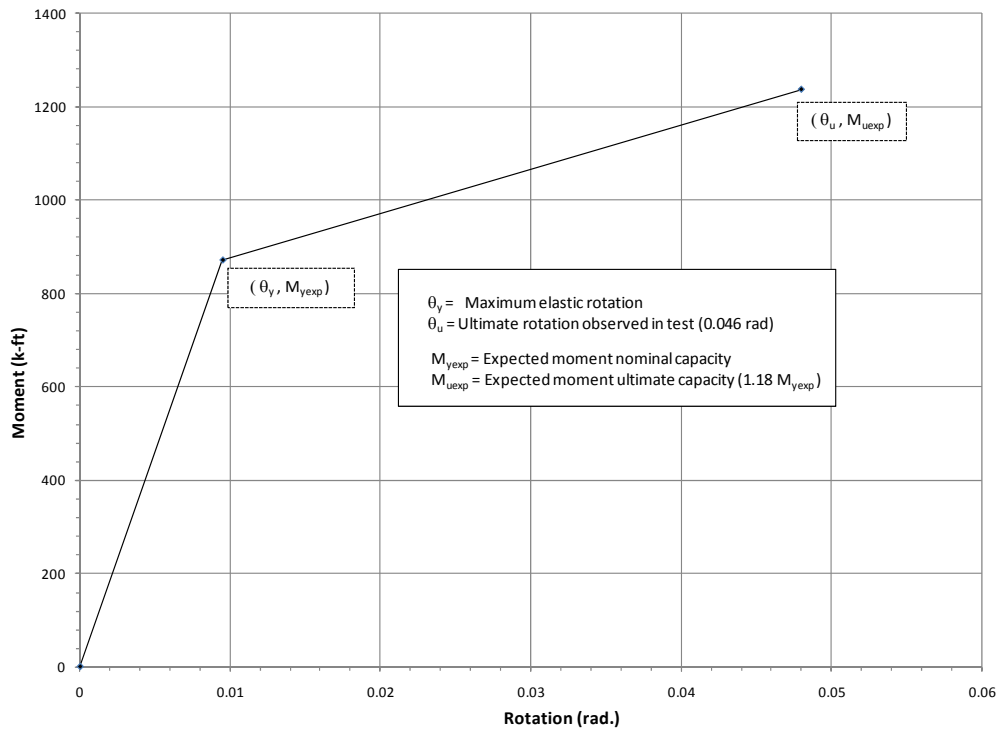

Figure 39 – Back bone curve for beam rotation hinge

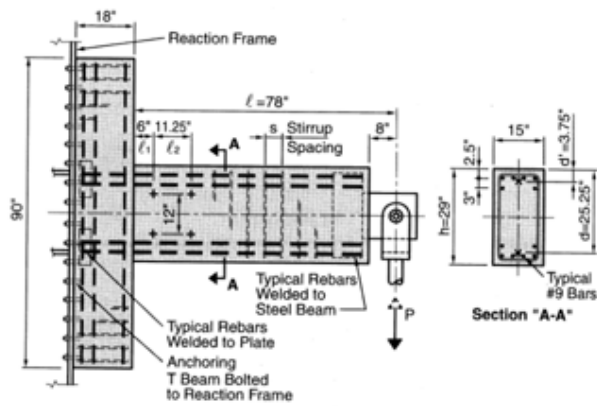

Figure 40 – Beam test subassembly as performed by Popov et al. (1972)

Figure taken from *The Seismic Design of Reinforced and Precast Concrete Buildings* by Englekirk (2003)

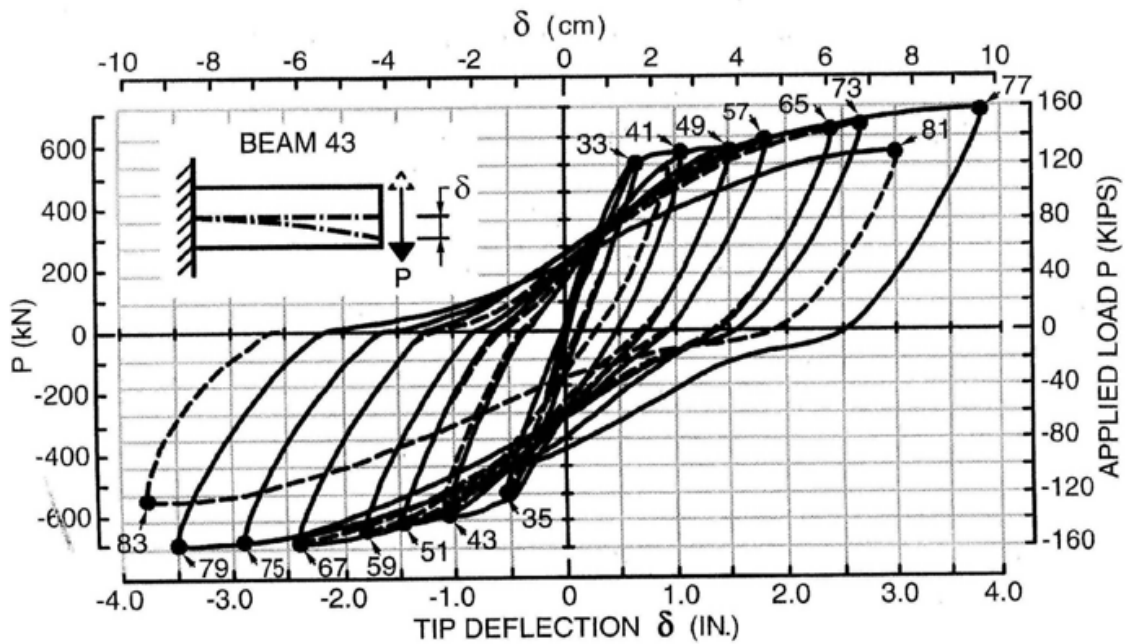

Figure 41 – Force–deflection curve from test performed by Popov et al. (1972)

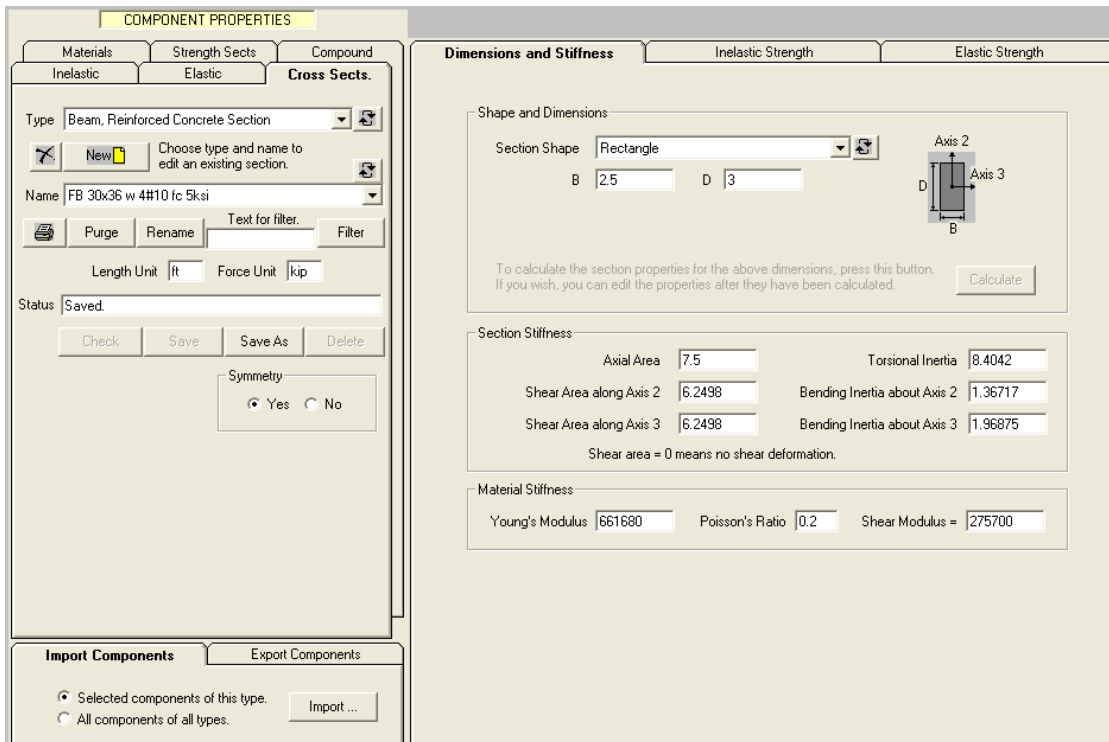

Figure 42 – Frame beam cross section screen shot from Perform 3D (2007)

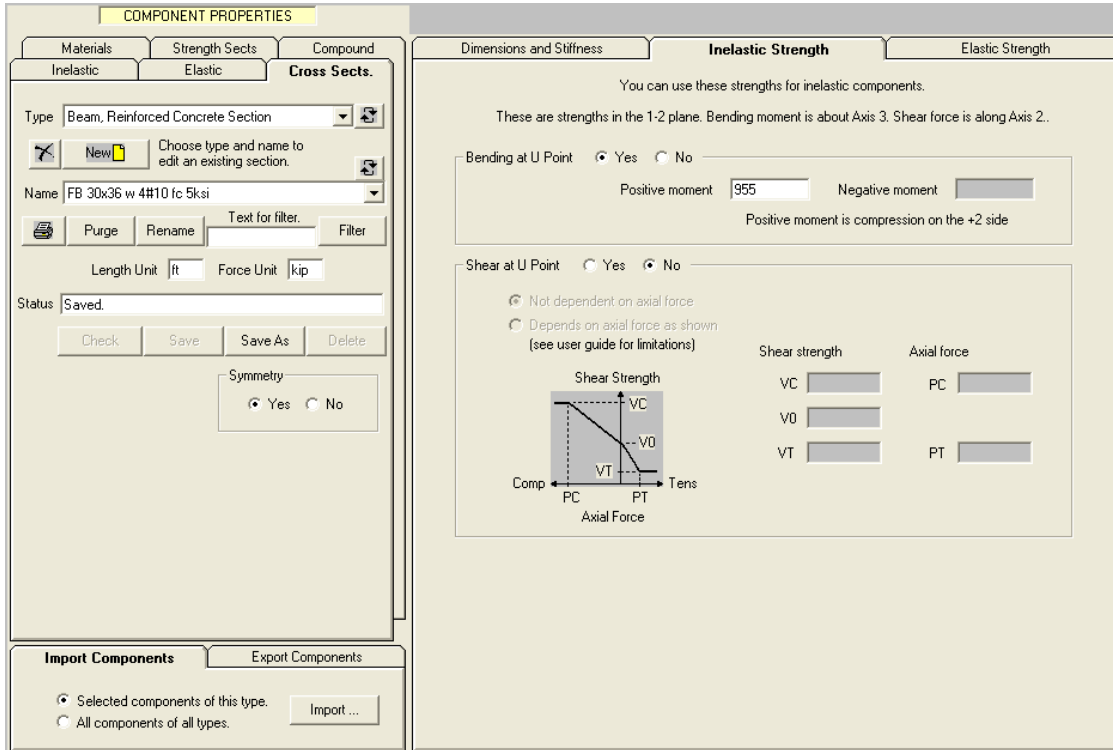

Figure 43 - Frame beam cross section screen shot from Perform 3D (2007)

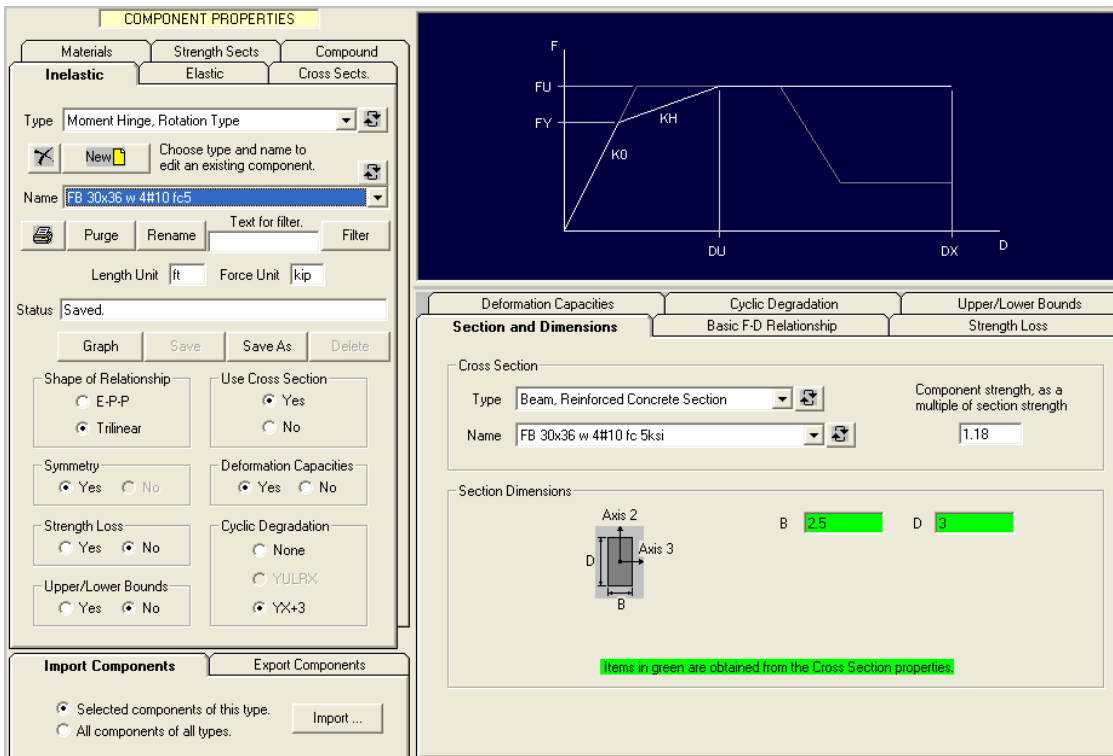

Figure 44 - Frame beam rotation moment hinge screen shot from Perform 3D (2007)

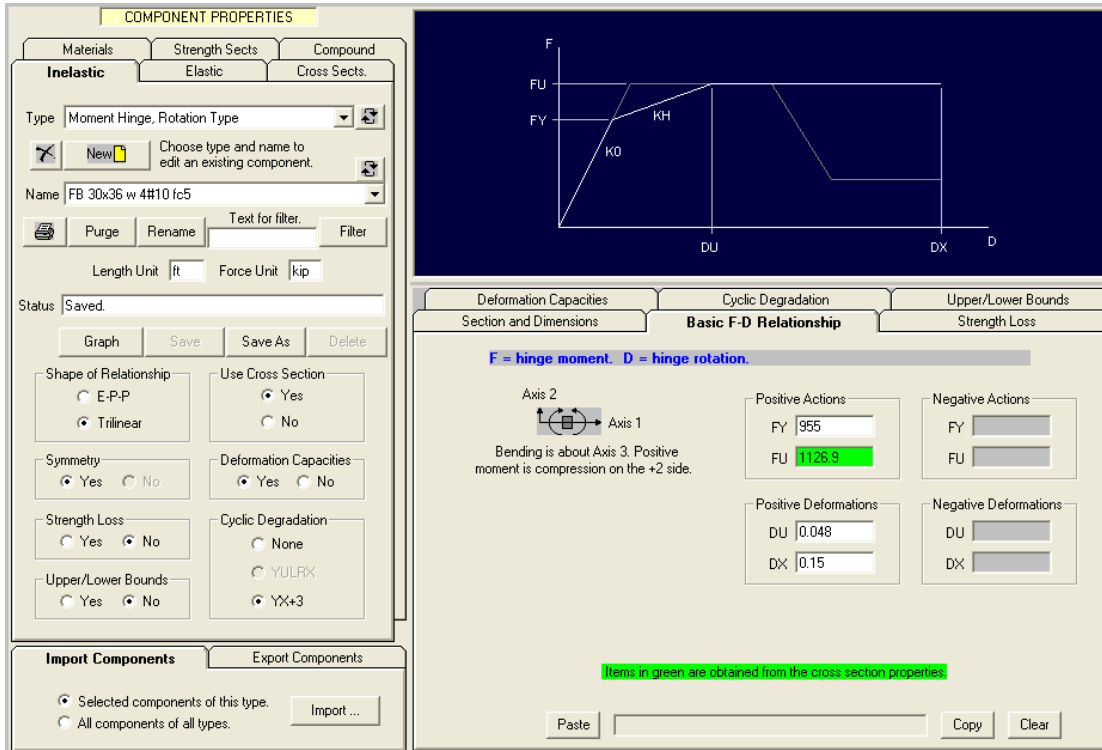

Figure 45 - Frame beam rotation moment hinge screen shot from Perform 3D (2007)

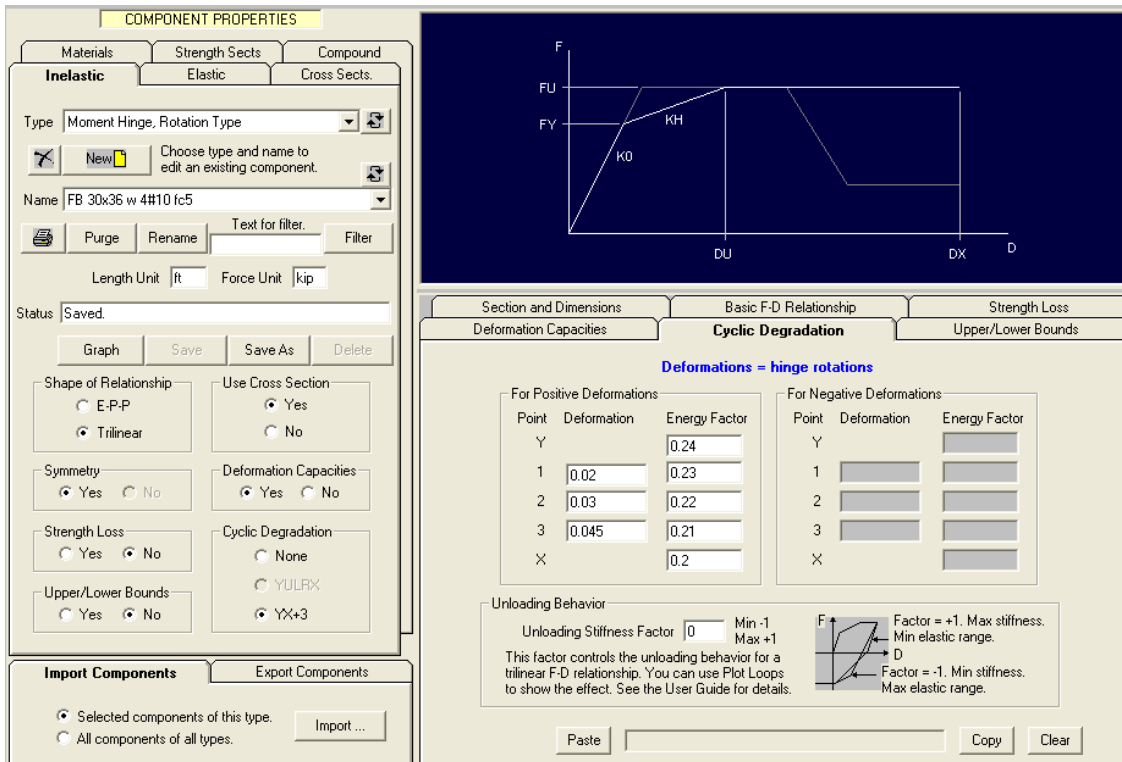

Figure 46 - Frame beam rotation moment hinge screen shot from Perform 3D (2007)

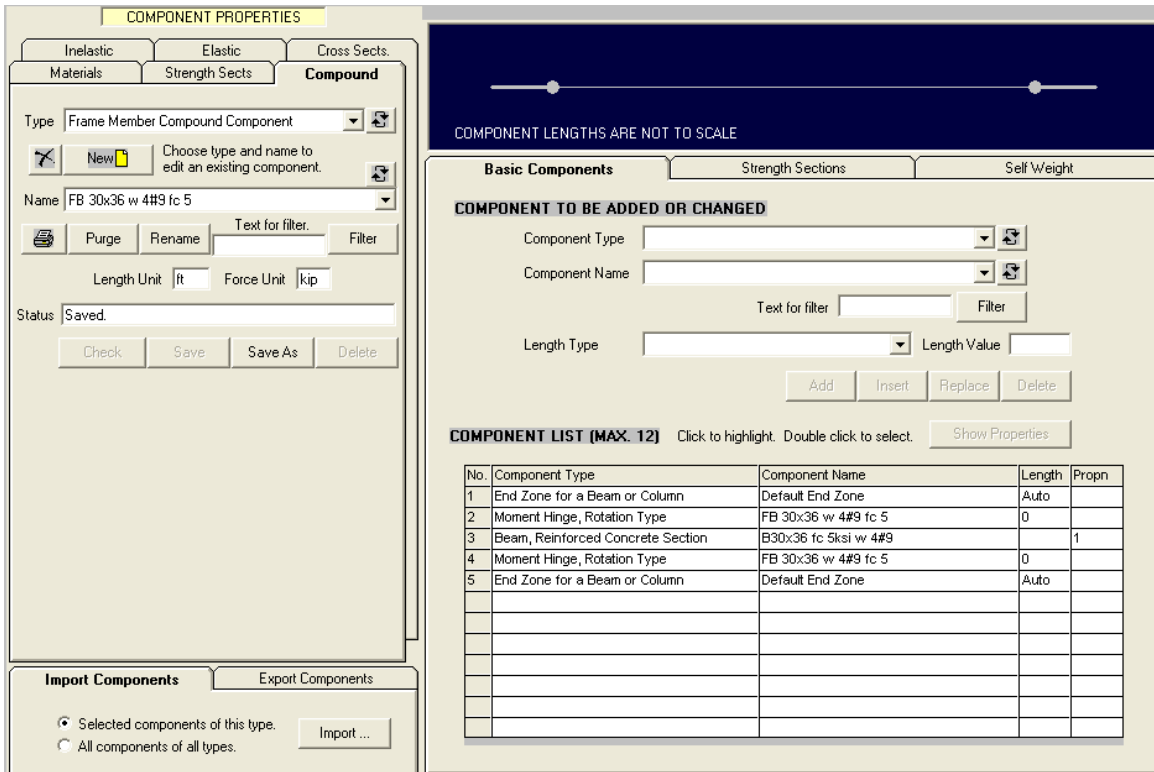

Figure 47 - Frame beam compound component screen shot from Perform 3D (2007)

4.2.5 Moment Frame Column Properties

Plastic hinges are modeled at the top and bottom ends of every column. Columns at the upper levels are expected to remain elastic but incursions into non-linear behavior are acceptable if the integrity of the structure is not compromised.

To define a column plastic hinge, a moment-axial capacity interaction curve is calculated using the column’s expected material properties. The back bone curve is elastic-perfectly plastic, meaning the column strength doesn’t change once it reaches the “yield” point.

The following figures show an example used in Perform 3D (2007) to define a column at the seismic base with plastic hinges at the face of the beam.

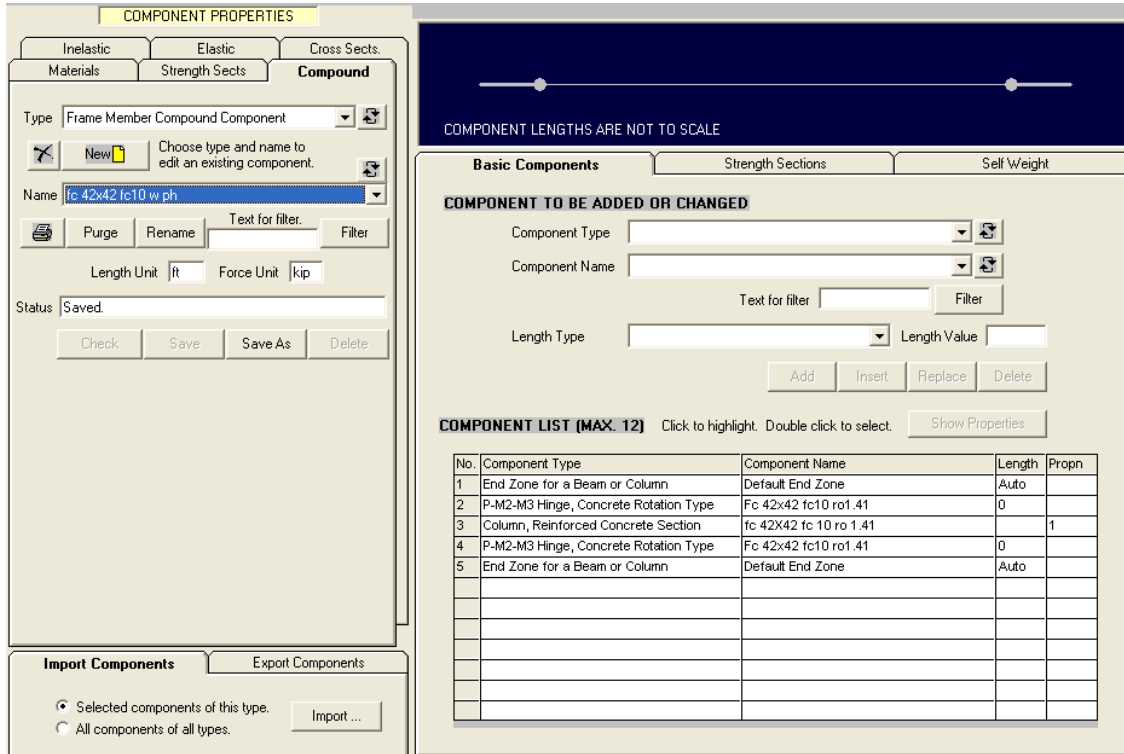

Figure 48 – Frame column compound component screen shot from Perform 3D (2007)

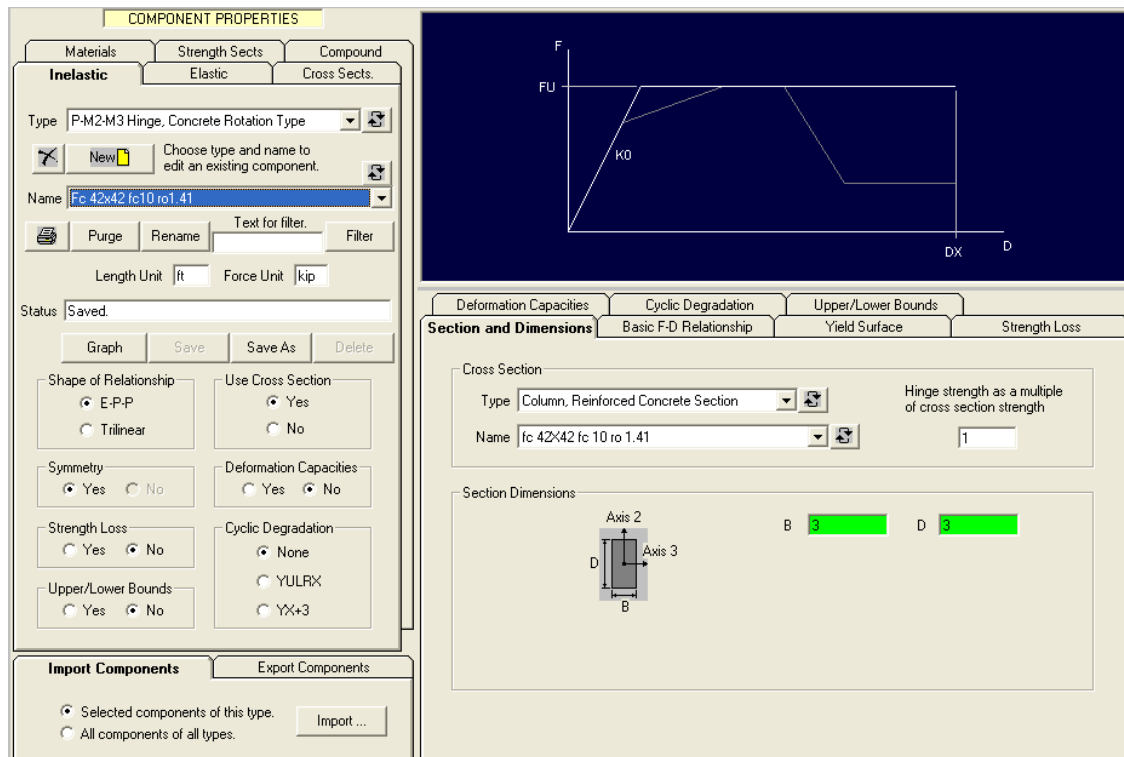

Figure 49 – Frame column plastic hinge screen shot from Perform 3D (2007)

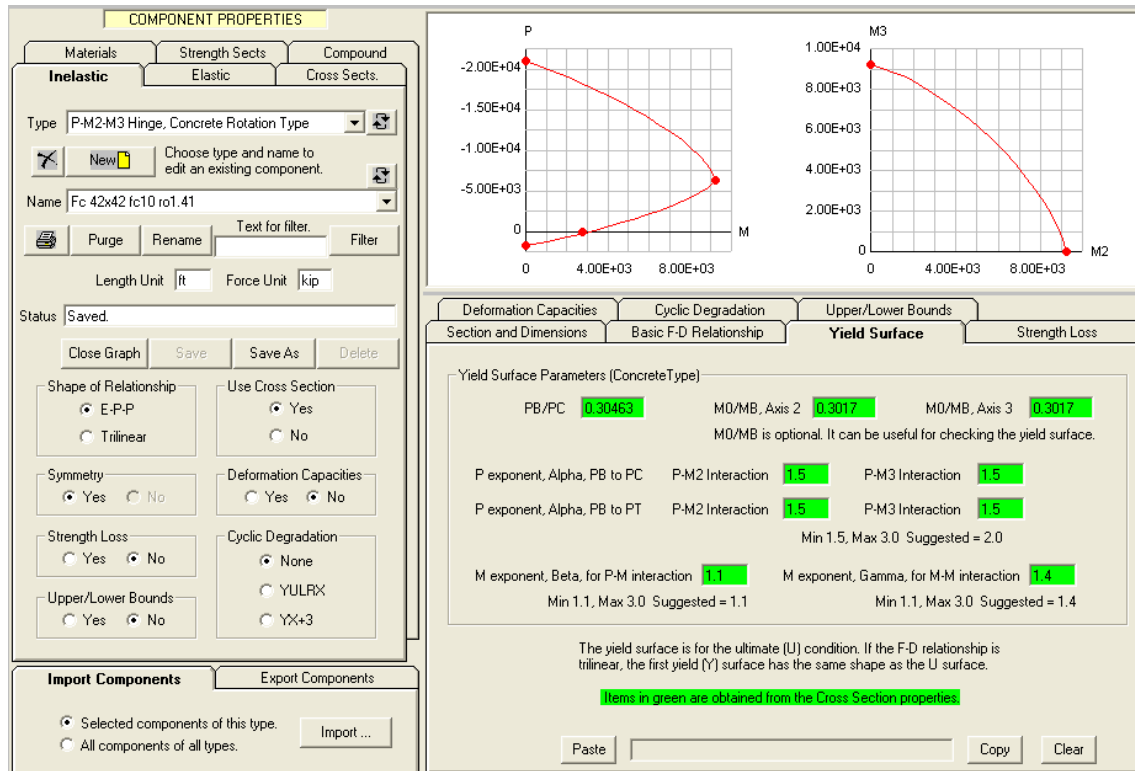

Figure 50 – Frame column plastic hinge screen shot from Perform 3D (2007)

4.2.6 Slab Modeling at Ground Level and Below

The slabs at ground level and below are modeled as a shell element with its stiffness modified per Table 3. The stiffness factors are applied to the elastic modulus when defining the material. The shear modulus is calculated by Perform 3D (2007) using Poisson's ratio. The following figures show the screen shots used to define a slab in Perform 3D (2007).

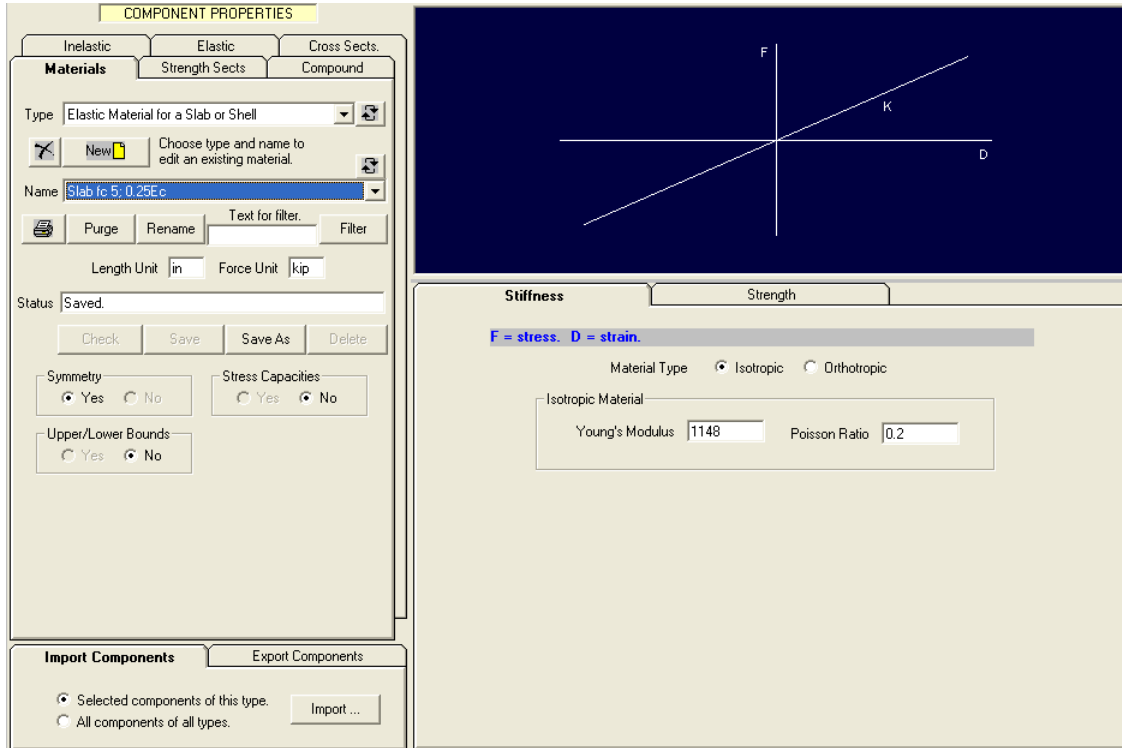

Figure 51 – Slab elastic material screen shot from Perform 3D (2007)

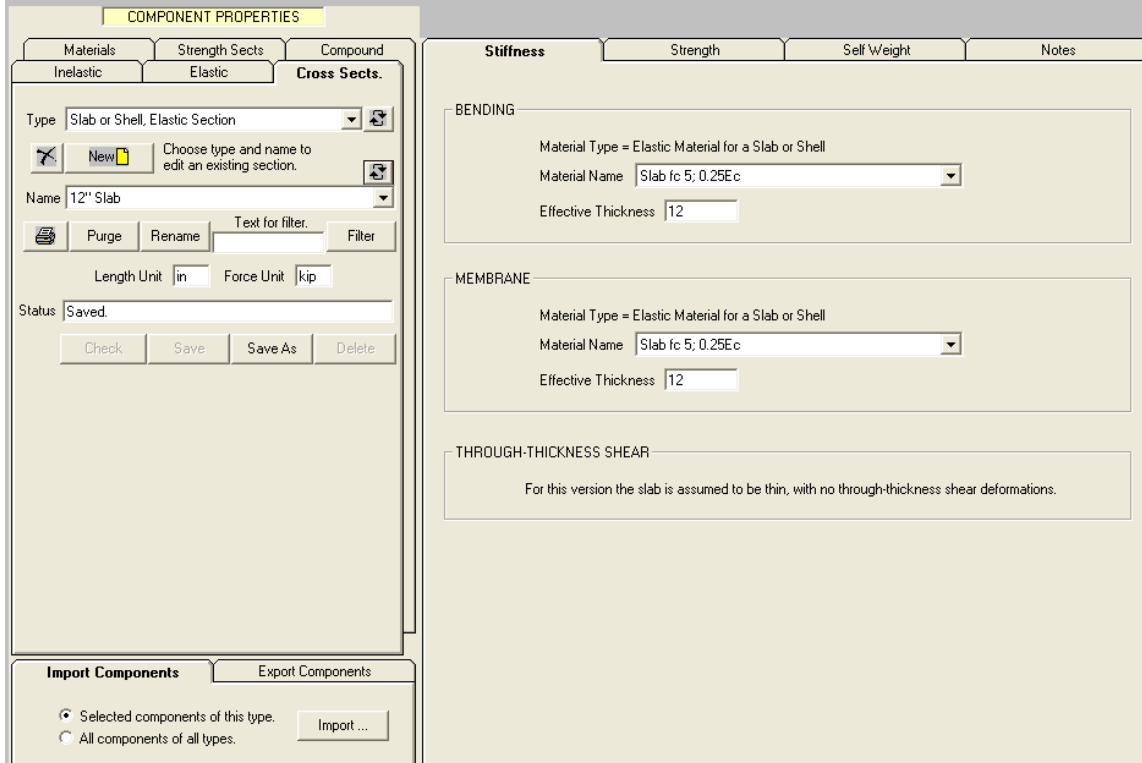

Figure 52 – Slab elastic cross section screen shot from Perform 3D (2007)

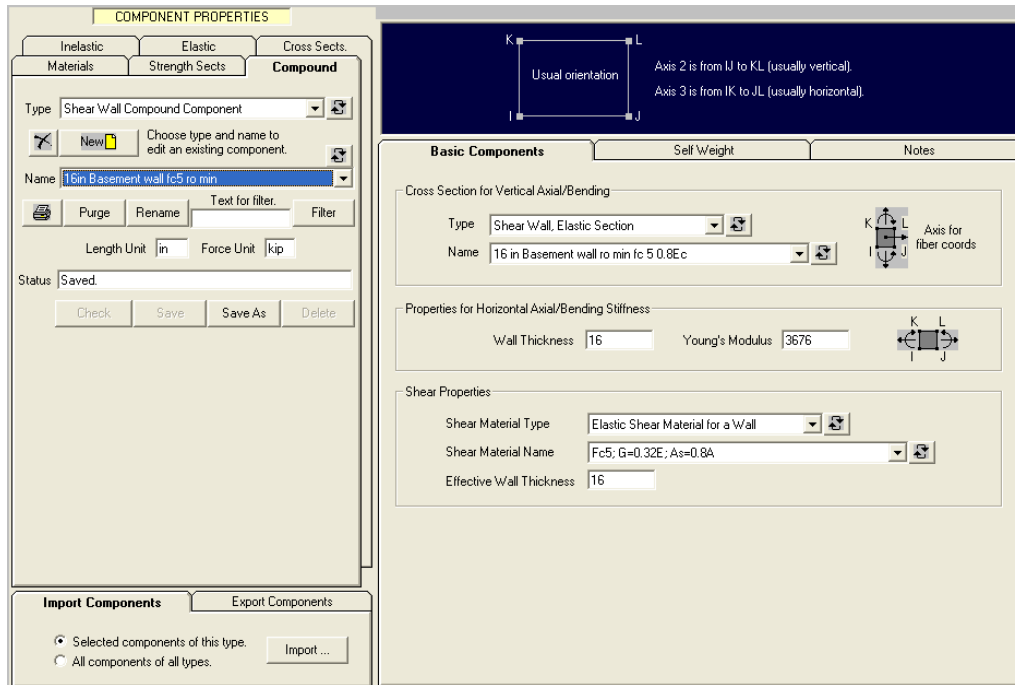

Figure 53 – Slab compound component screen shot from Perform 3D (2007)

4.2.7 Basement Wall Properties

Basement walls are modeled as elastic finite elements with its stiffness modified per Table 3. The following figures show the screen shots used to define a basement wall in Perform 3D (2007).

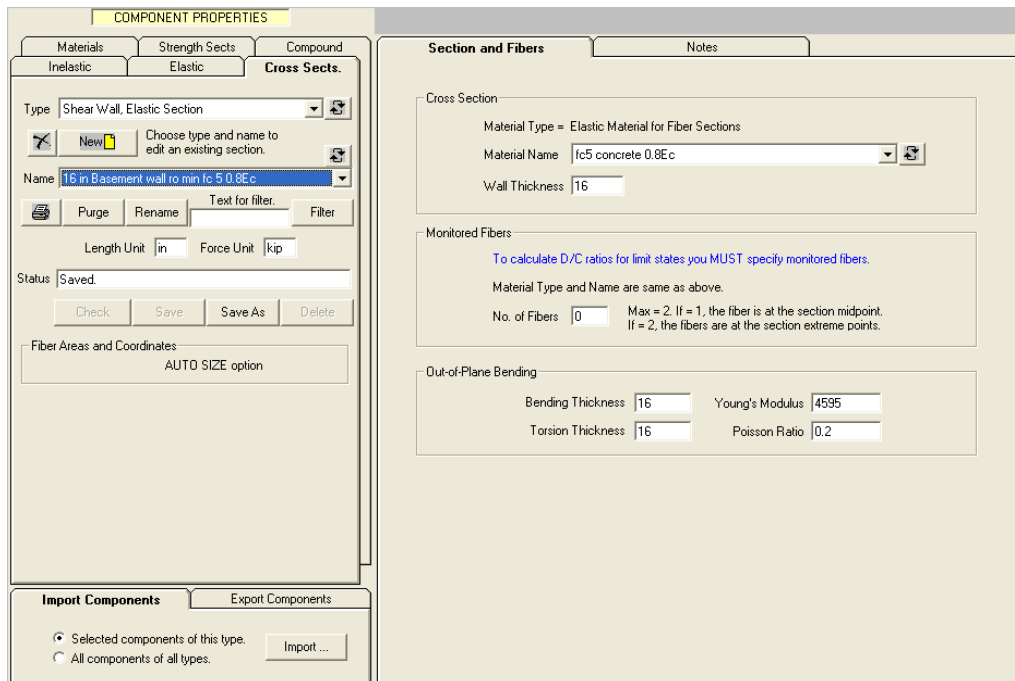

Figure 54 – Basement wall cross section screen shot from Perform 3D (2007)

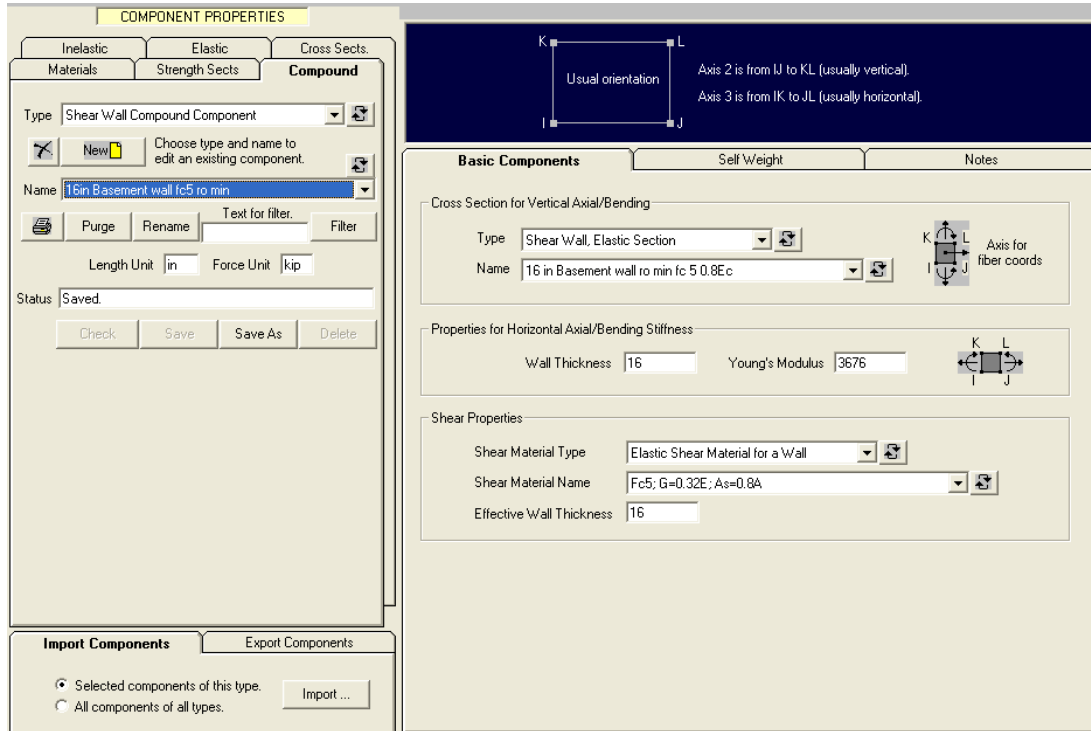

Figure 55 – Basement wall compound component screen shot from Perform 3D (2007)

4.2.8 Damping

Rayleigh damping is used to run the time-history non-linear analyses. To define the damping curve, the damping is set at 2.5% of critical damping at a period of $0.2T_1$, and at a period of $0.9 T_1$, T_1 being the fundamental period of the structure. The α and β values are automatically calculated by Perform 3D (2007).

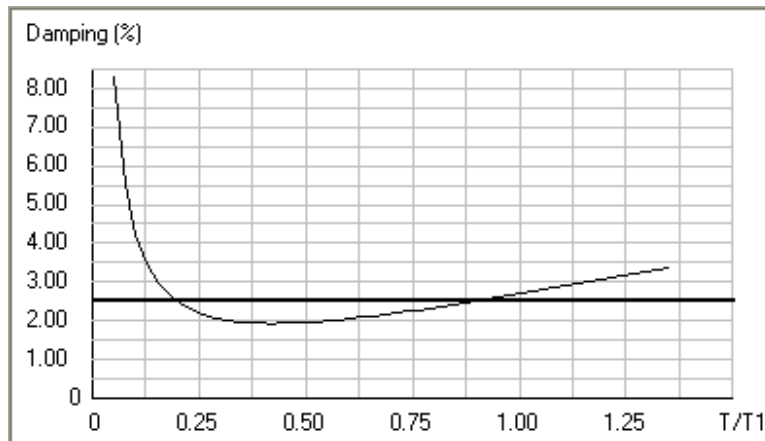

Figure 56 – Rayleigh damping as defined in Perform 3D

ANALYSIS SERIES

Check Structure

The structure is checked automatically when you start a new analysis series. If you wish, you can check it beforehand by pressing this button.

TYPE OF OPERATION

Start a new analysis series

Continue or change an existing series Exit

Delete an existing series

CONTINUE OR CHANGE AN EXISTING SERIES

Series name: UnChange

Description:

Change analysis series properties below if desired. Press OK to save properties and continue.

OK

Basic + Masses
Modal Damping
Rayleigh Damping
U/L Bounds
Quick'n'Dirty

Basic Values

Alpha-M Options

Beta-K Options

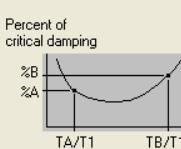

Percent of critical damping

%B

%A

TA/T1

TB/T1

Period, as a multiple of Mode 1 period

Damping varies as shown. Specify period ratios and damping % at points A and B, then press Draw Graph.

For zero damping, leave all boxes blank. For Beta-K only leave TB/T1 and %B blank. For Alpha-M only leave TA/T1 and %A blank.

Period Ratio, T/T1	Damping %
Point A	<input type="text" value="0.2"/> <input type="text" value="2.5"/>
Point B	<input type="text" value="0.9"/> <input type="text" value="2.5"/>

Draw Graph

If the damping variation is not OK, close the graph and try again.

Alpha =

Beta =

Figure 57 – Damping definition screen shot from Perform 3D

4.3 Results from Non-linear Analyses

The following figures represent the behavior of building 2B under the MCE records and its averages.

4.3.1 Overall Behavior

Table 13 – Summary of Building 2B Behavior under MCE

Shear at grade level	$V_x = 10,732$ kips	$V_y = 10,000$ kips
Core average peak shear at grade level	$V_x = 8,240$ kips	$V_y = 7,150$ kips
Core average peak overturning moment at grade level	$M_y = 952,328$ kip-ft	$M_x = 739,130$ kip-ft
Average maximum story drift from non-linear analyses	$\delta_x = 1.5\%$	$\delta_y = 1.0\%$

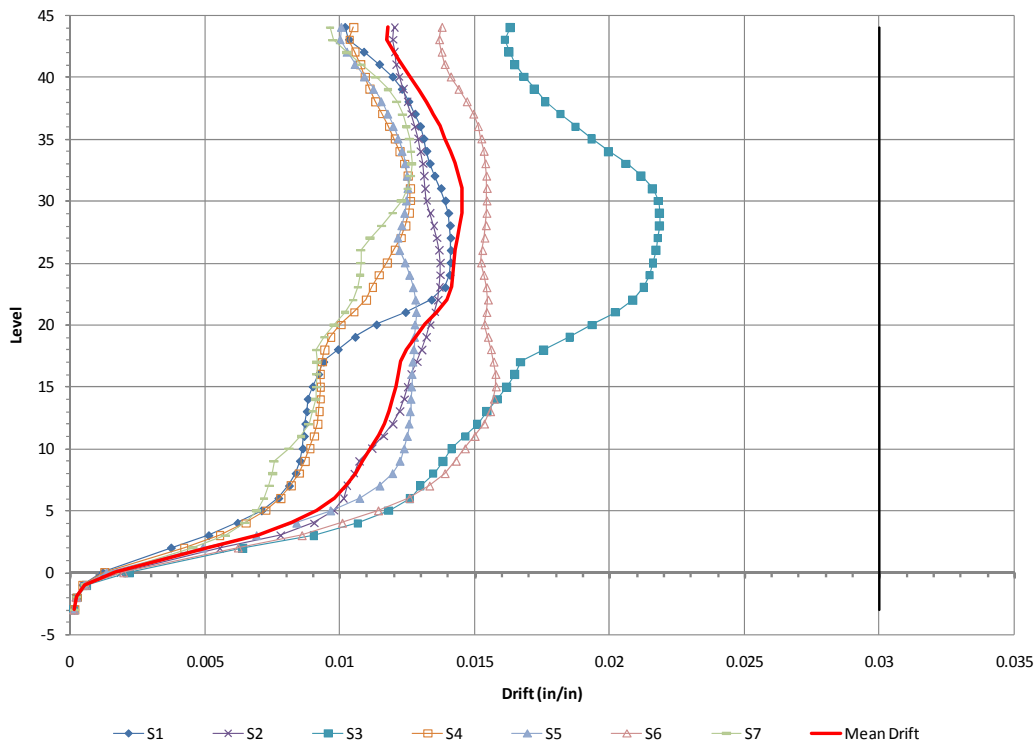

Figure 58 – Peak inter-story drifts on X direction

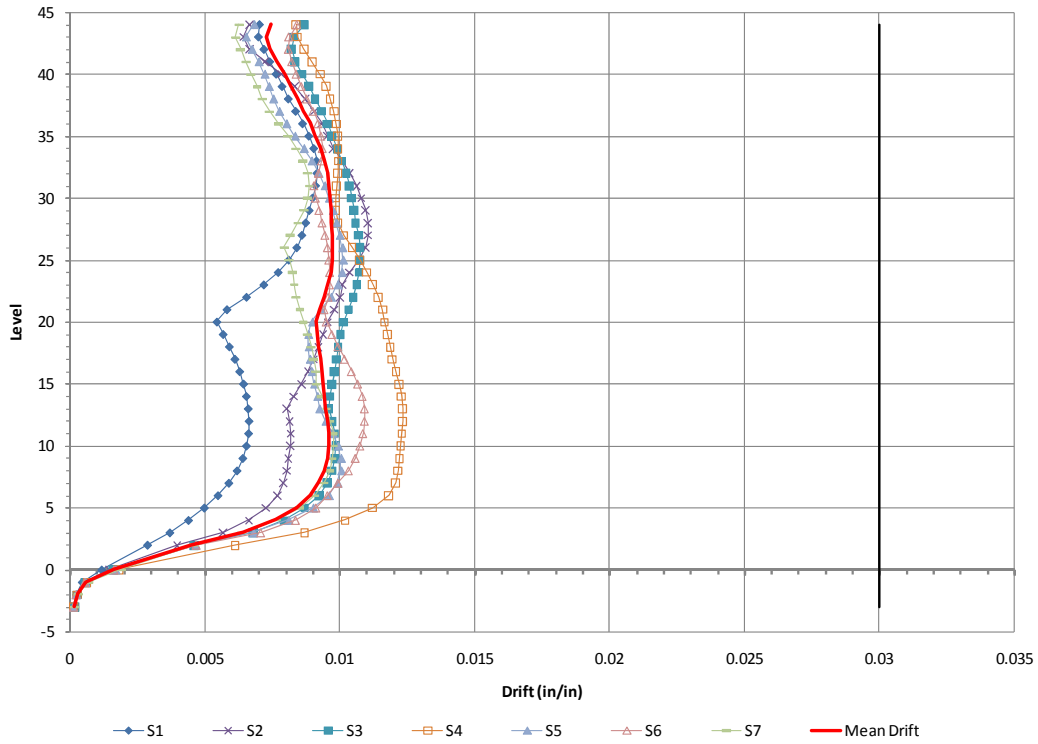

Figure 59 – Peak inter-story drifts on Y direction

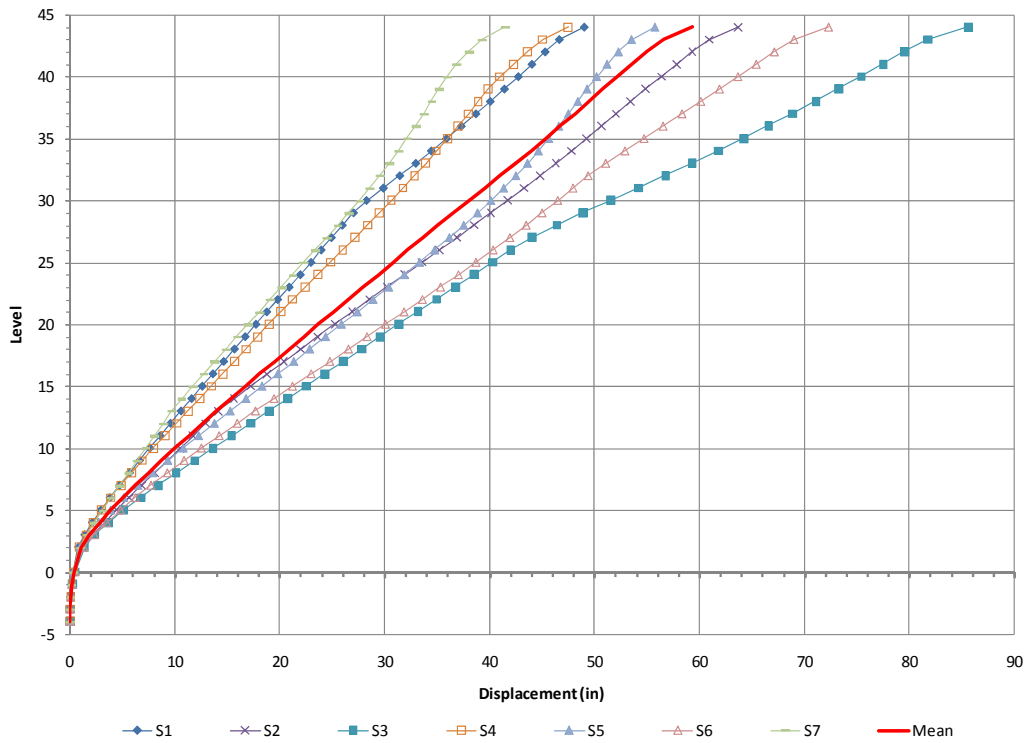

Figure 60 – Peak displacements at center of mass on X direction

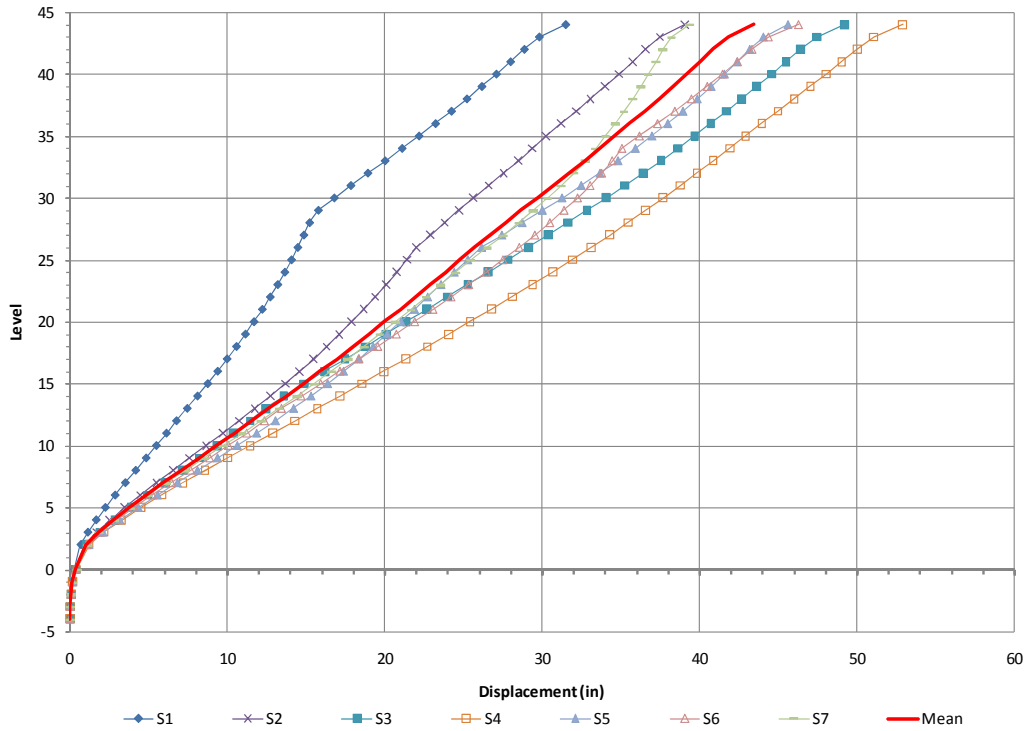

Figure 61 – Peak displacements at center of mass on Y direction

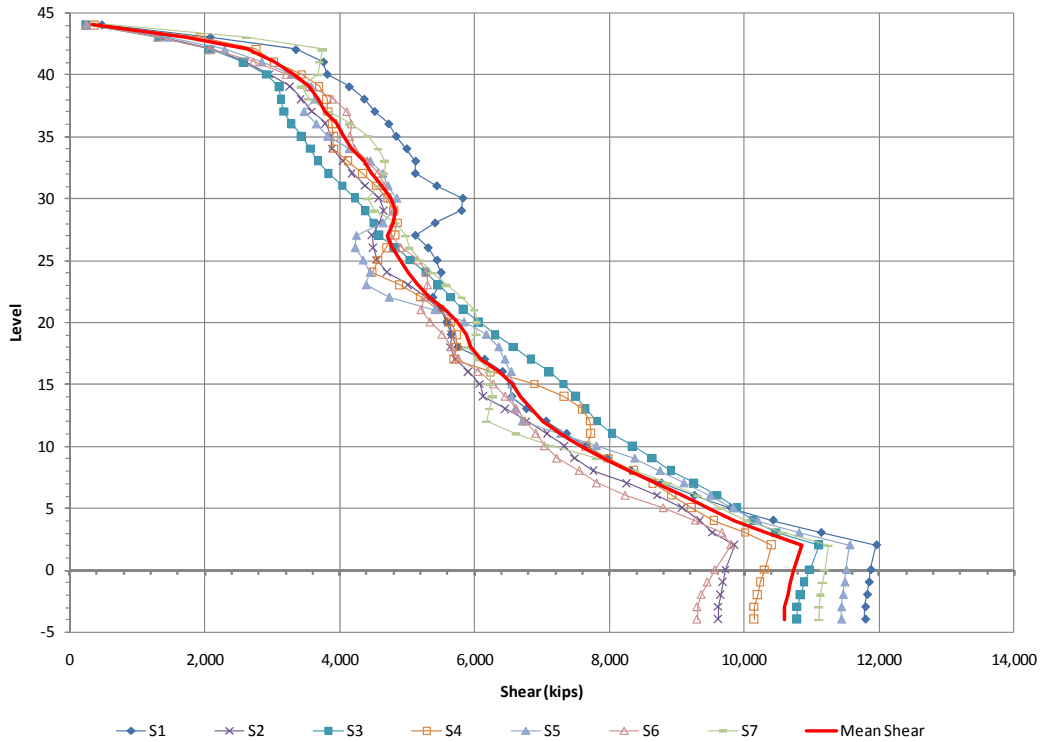

Figure 62 – Peak story shear on X direction

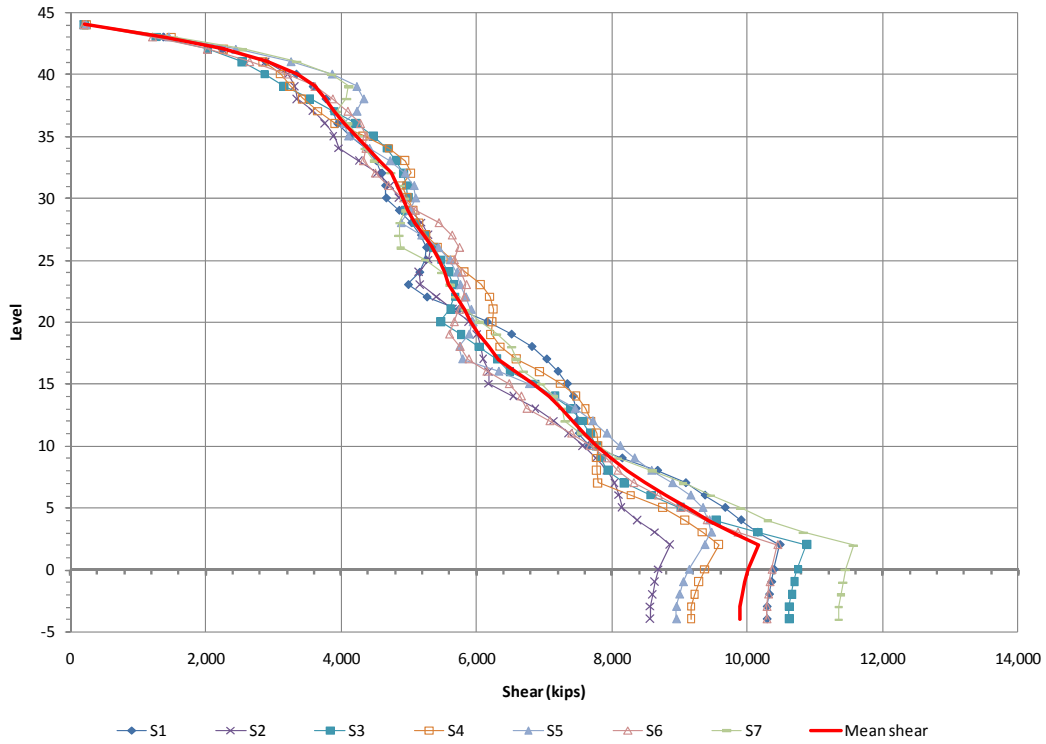

Figure 63 – Peak story shear on Y direction

4.3.2 Core Shear Wall

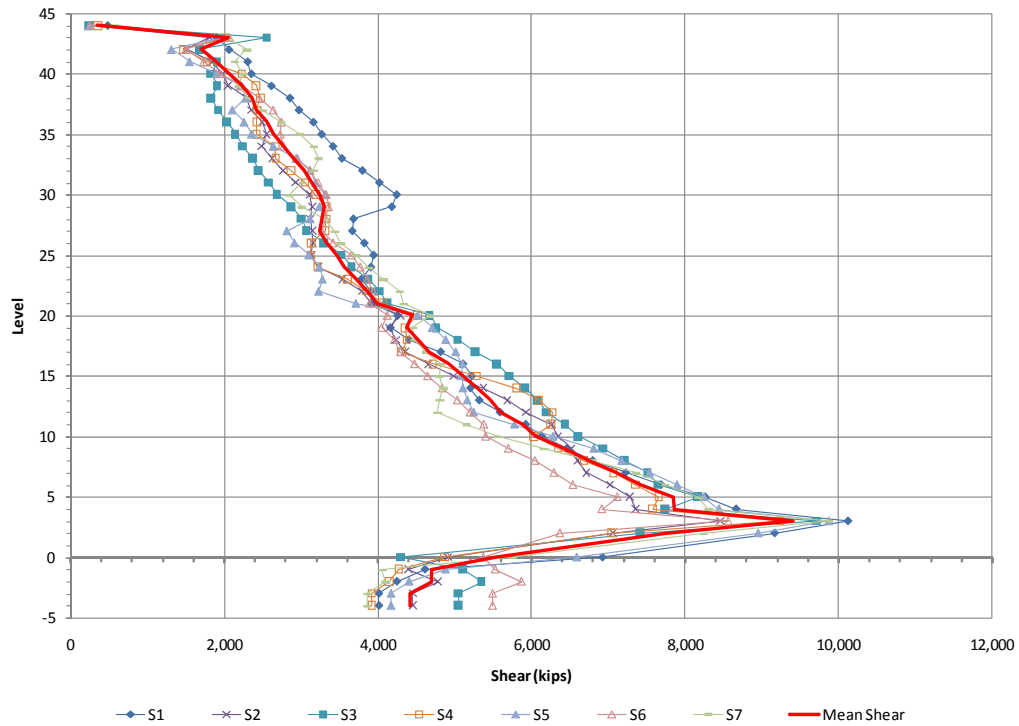

Figure 64 – Building 2B core peak shear on X direction

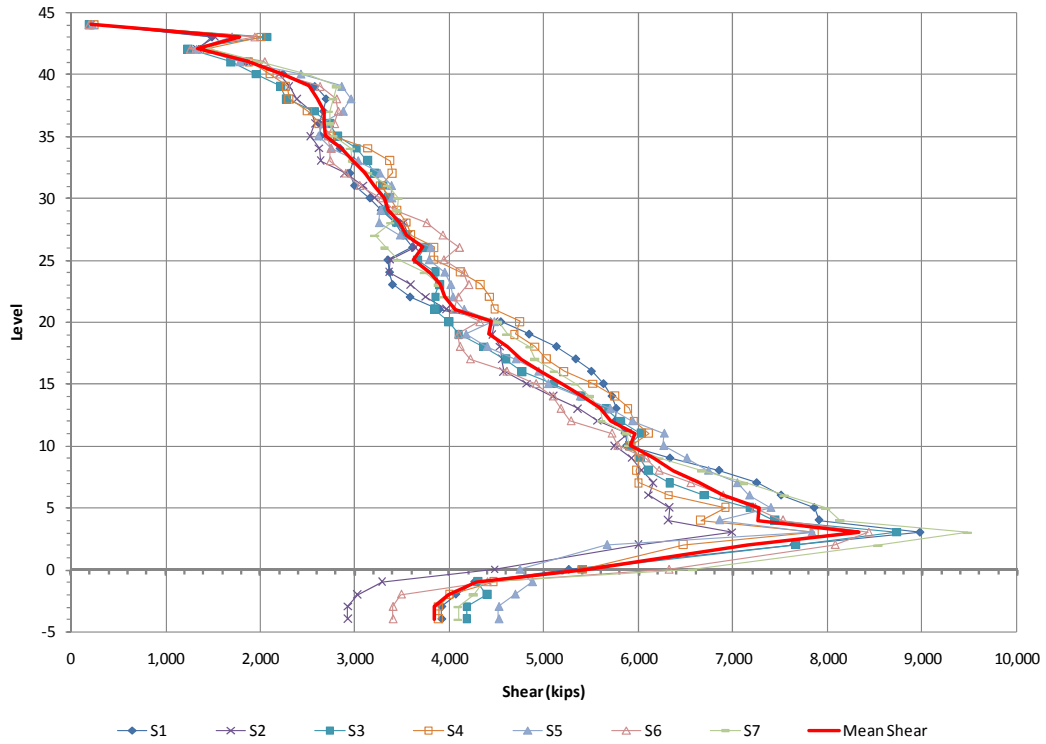

Figure 65 – Building 2B core peak shear on Y direction

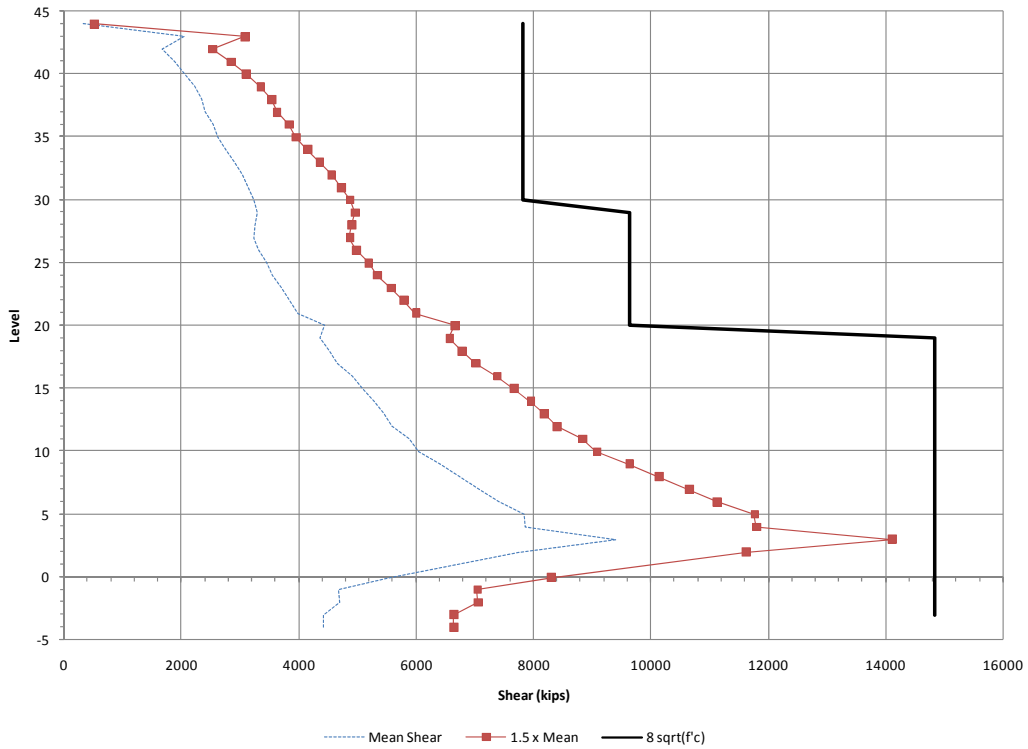

Figure 66 – Building 2B average core peak shear values on X direction

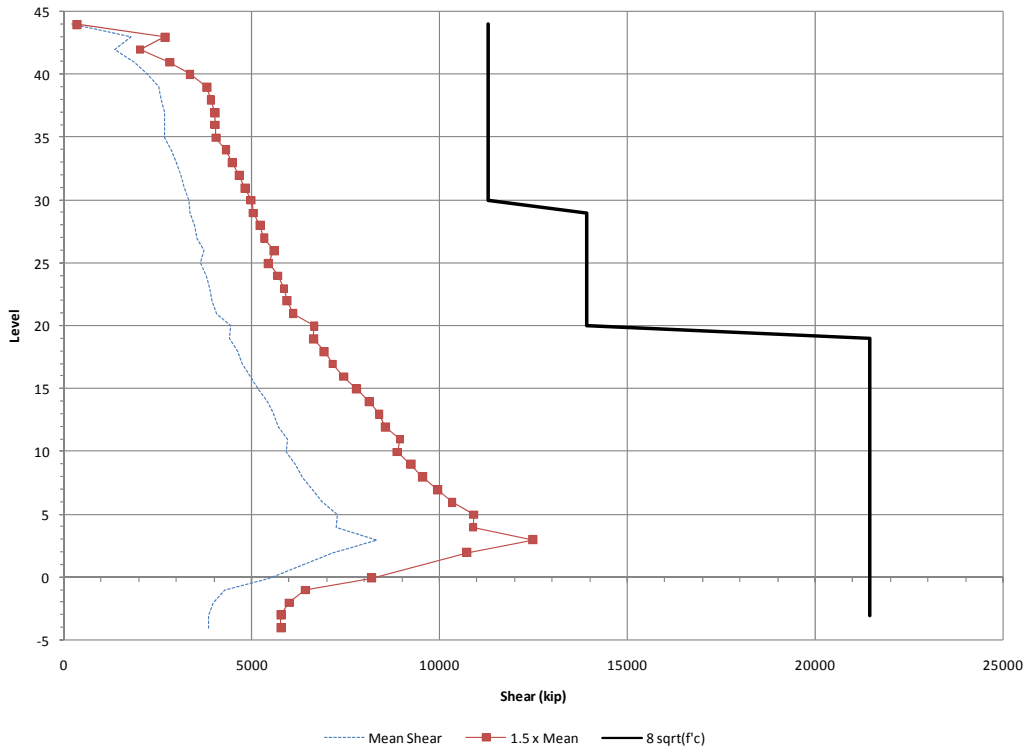

Figure 67 – Building 2B average core peak shear values on Y direction

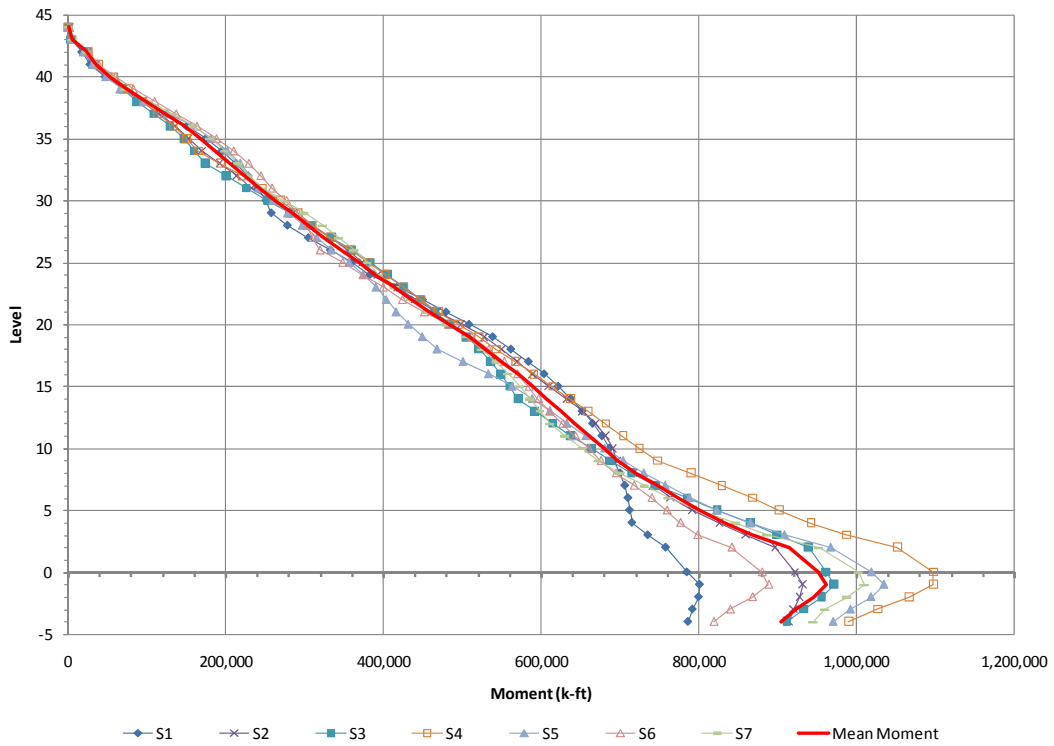

Figure 68 – Building 2B core peak overturning moment over X

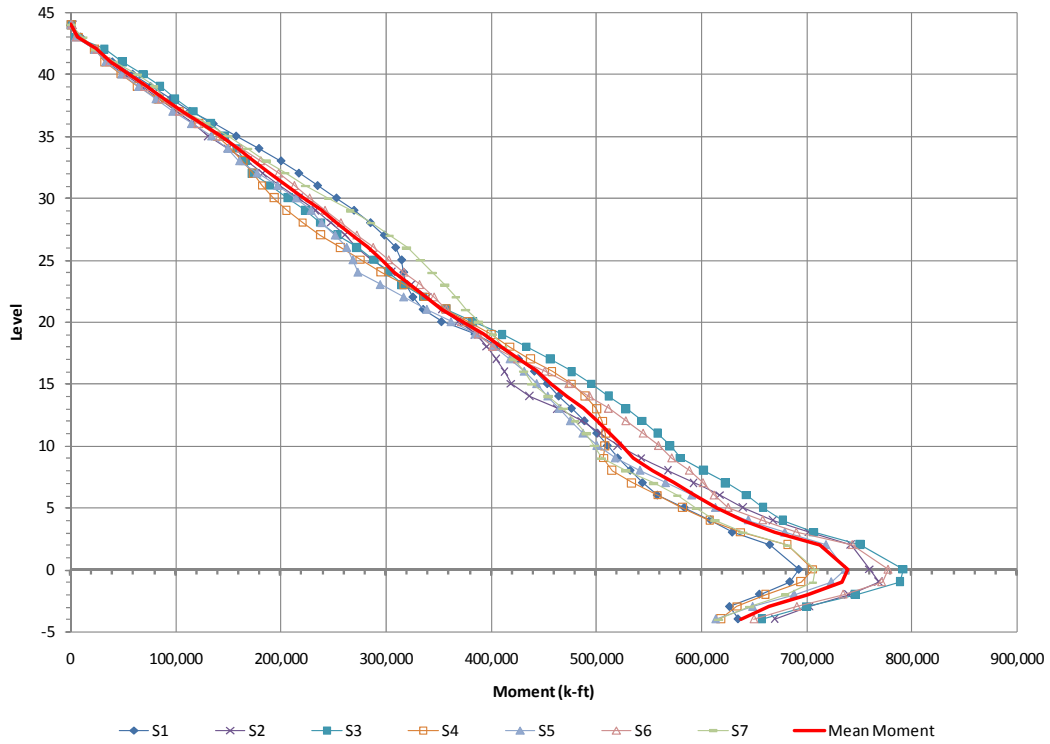

Figure 69 – Building 2B core peak overturning moment over Y

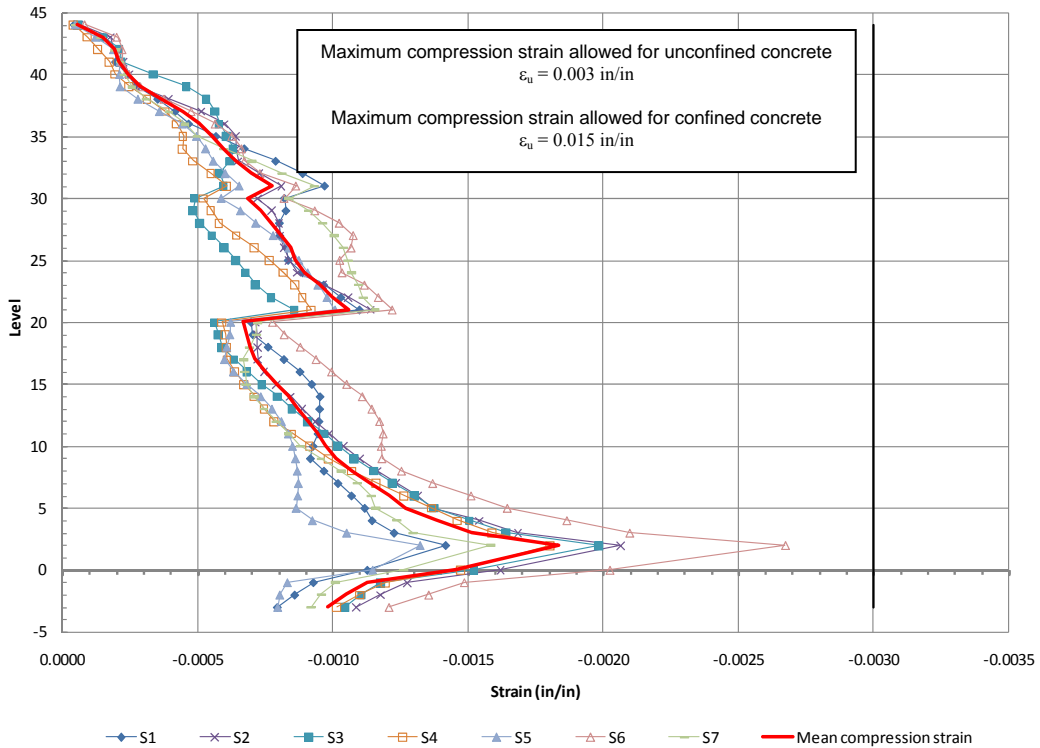

Figure 70 – Building 2B Maximum compression strains at core corner by Pier 1

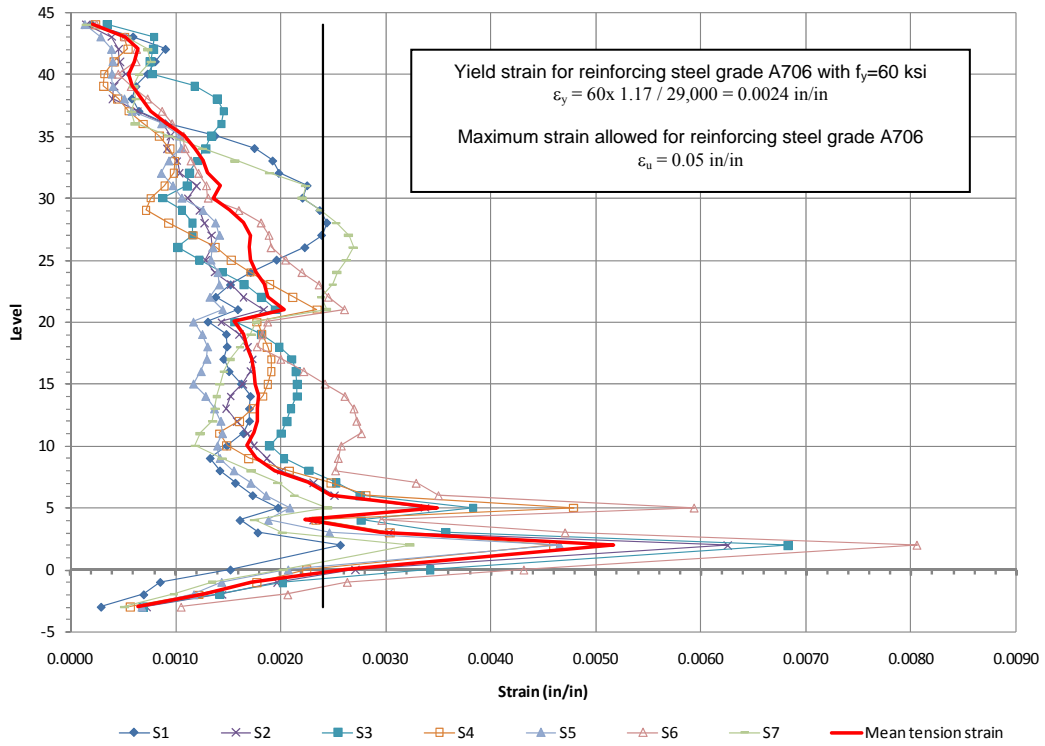

Figure 71 – Building 2B Maximum tension strains at core corner by Pier 1

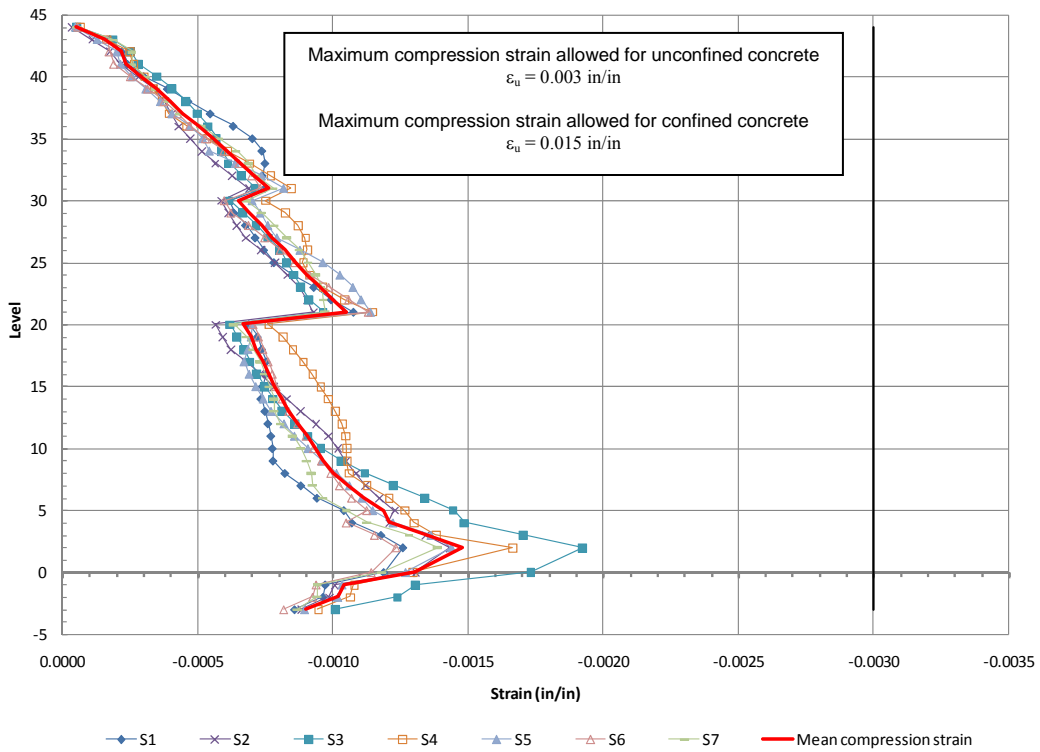

Figure 72 – Building 2B Maximum compression strains at core corner by Pier 2

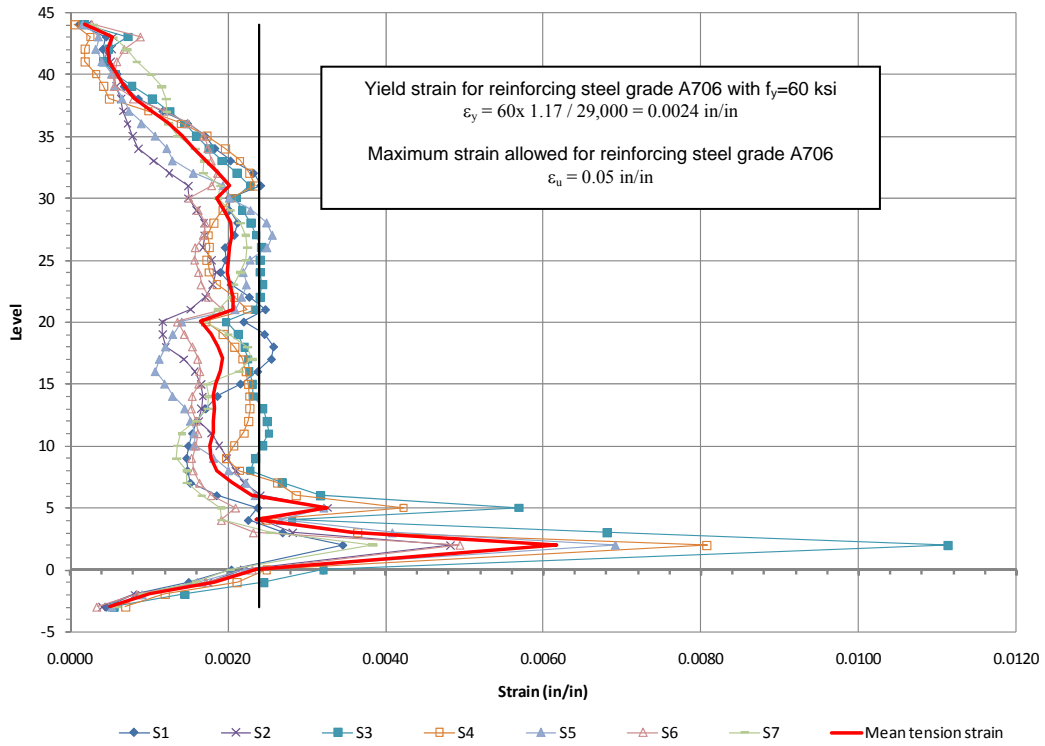

Figure 73 – Building 2B Maximum tension strains at core corner by Pier 2

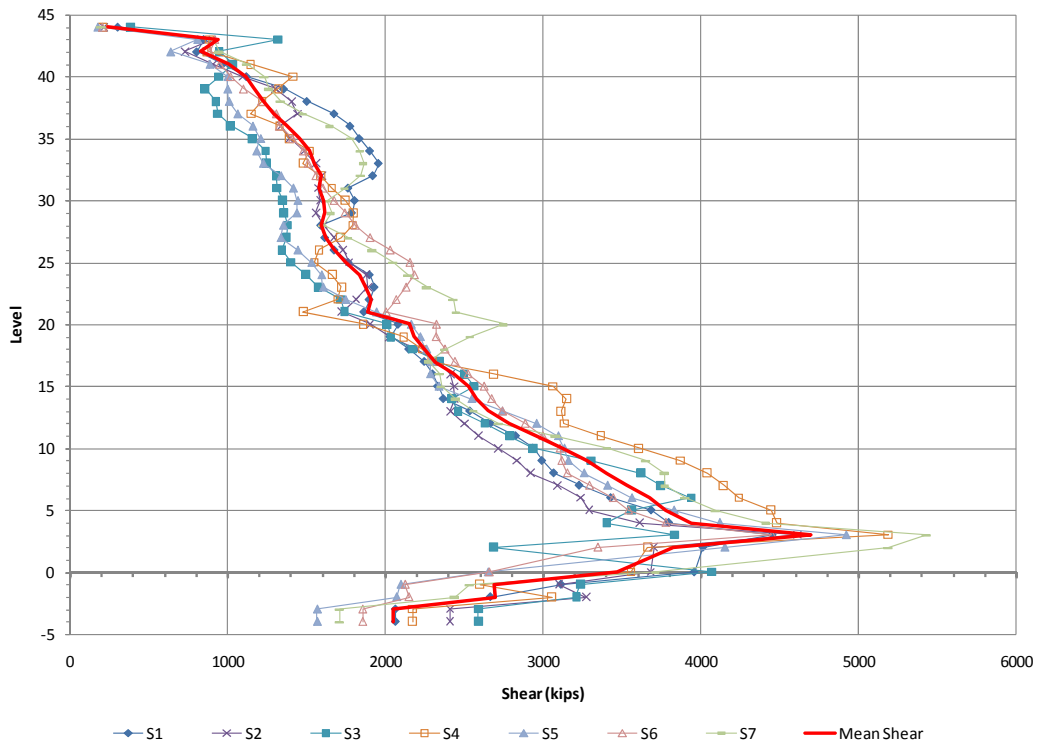

Figure 74 – Building 2B Pier 1 peak shear on X direction

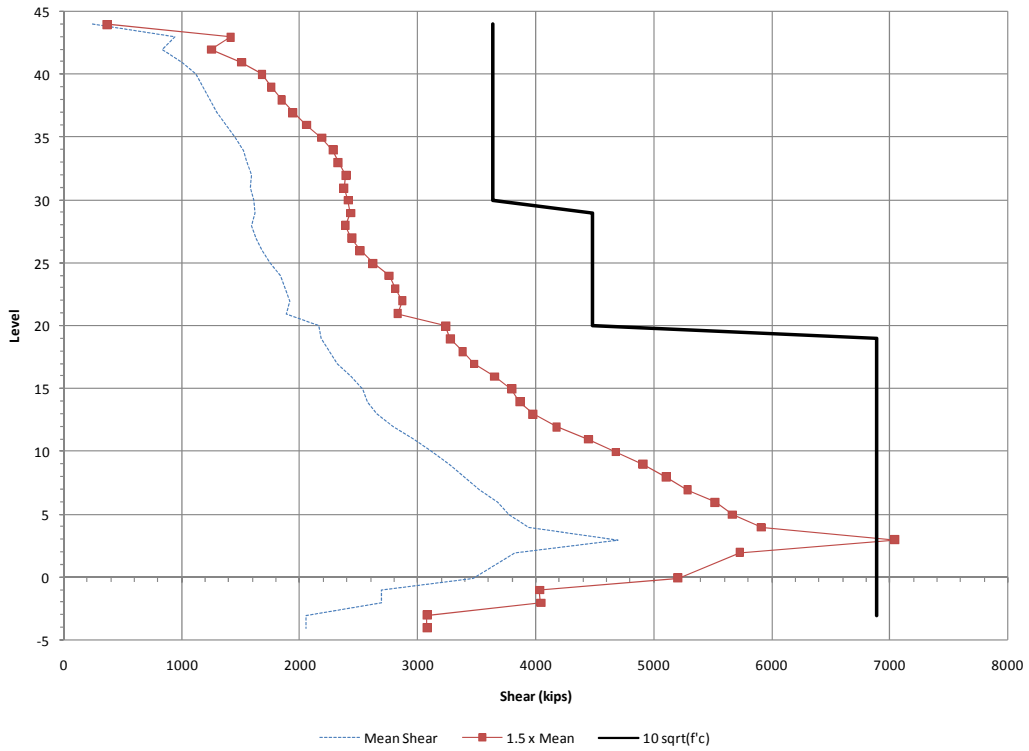

Figure 75 – Building 2B Pier 1 average peak shear on X direction

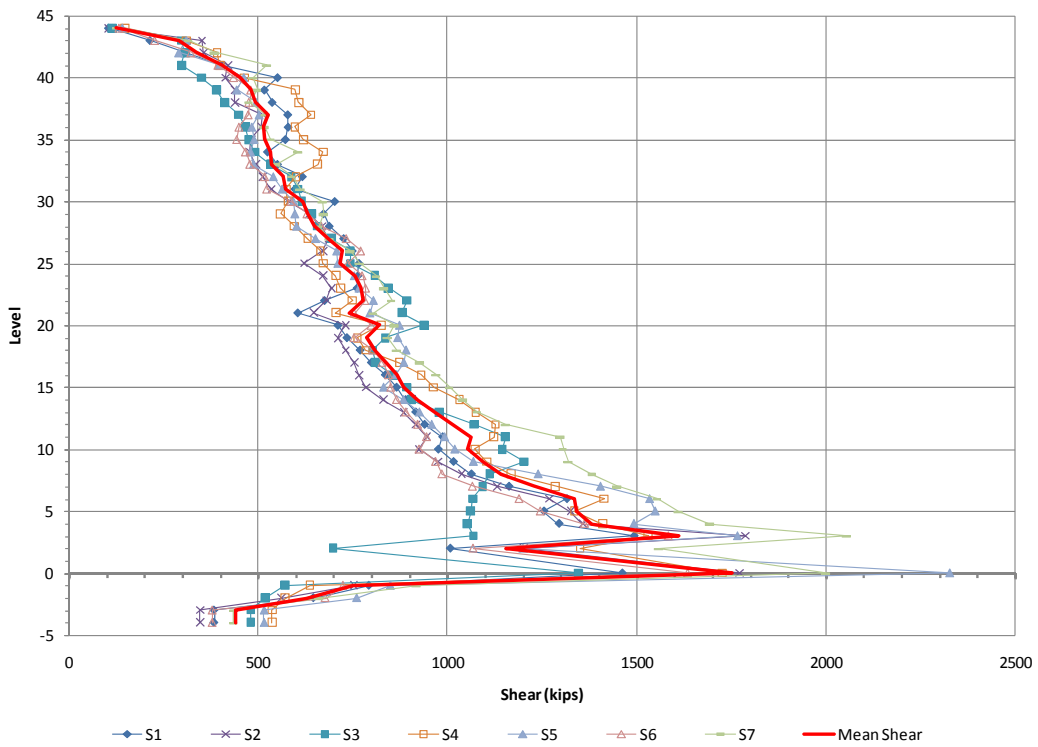

Figure 76 – Building 2B Pier 1 average peak shear on Y direction

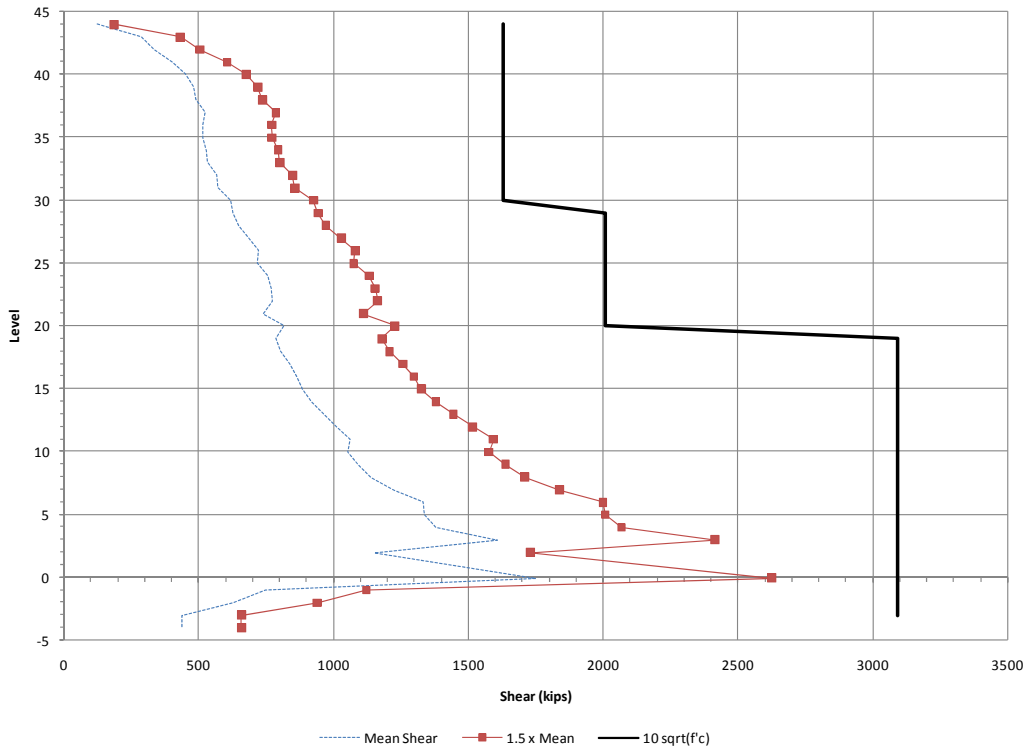

Figure 77 – Building 2B Pier 1 average peak shear on Y direction

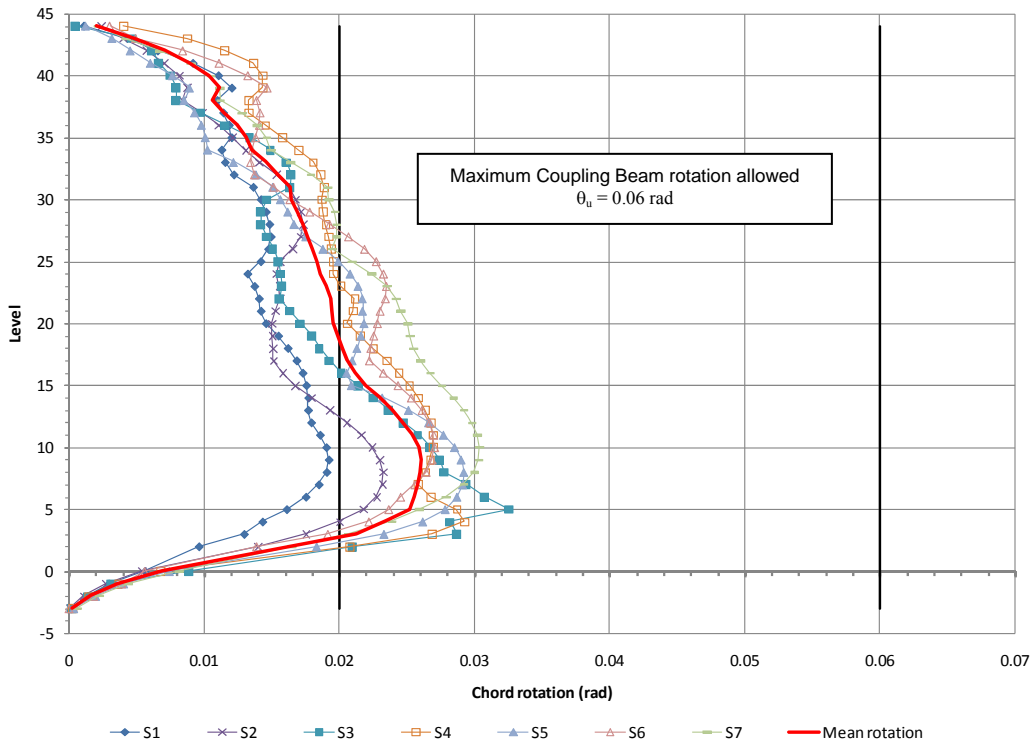

Figure 78 – Building 2B elevation “A” coupling beam peak rotations

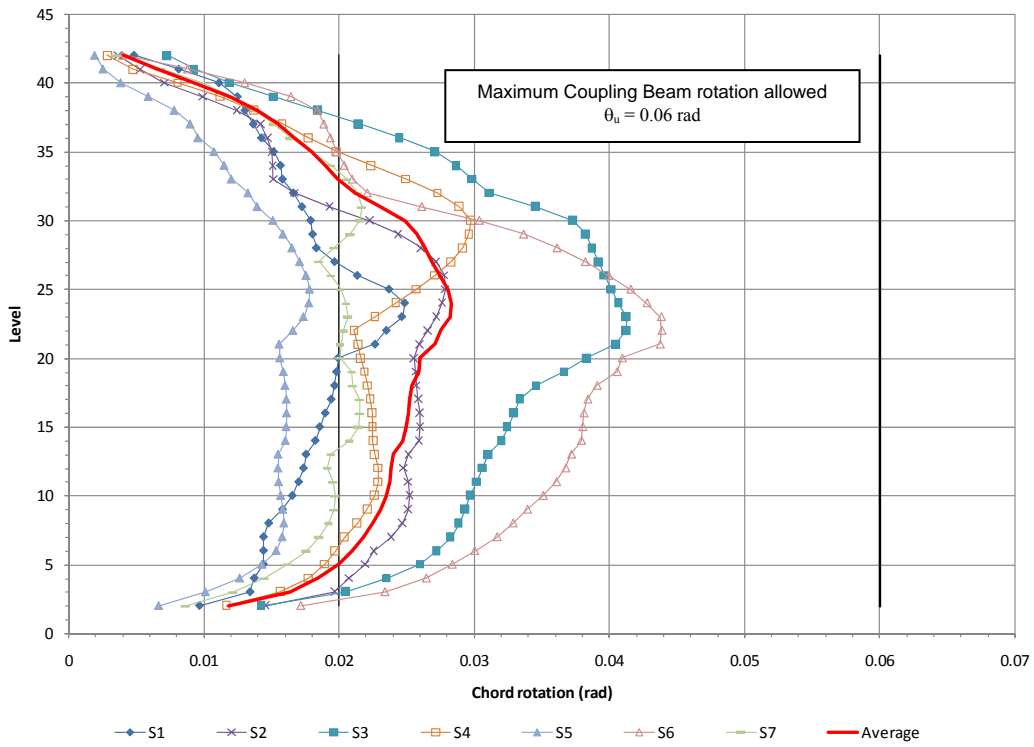

Figure 79 – Building 2B elevation “B” coupling beam peak rotations

4.3.3 Frame Behavior

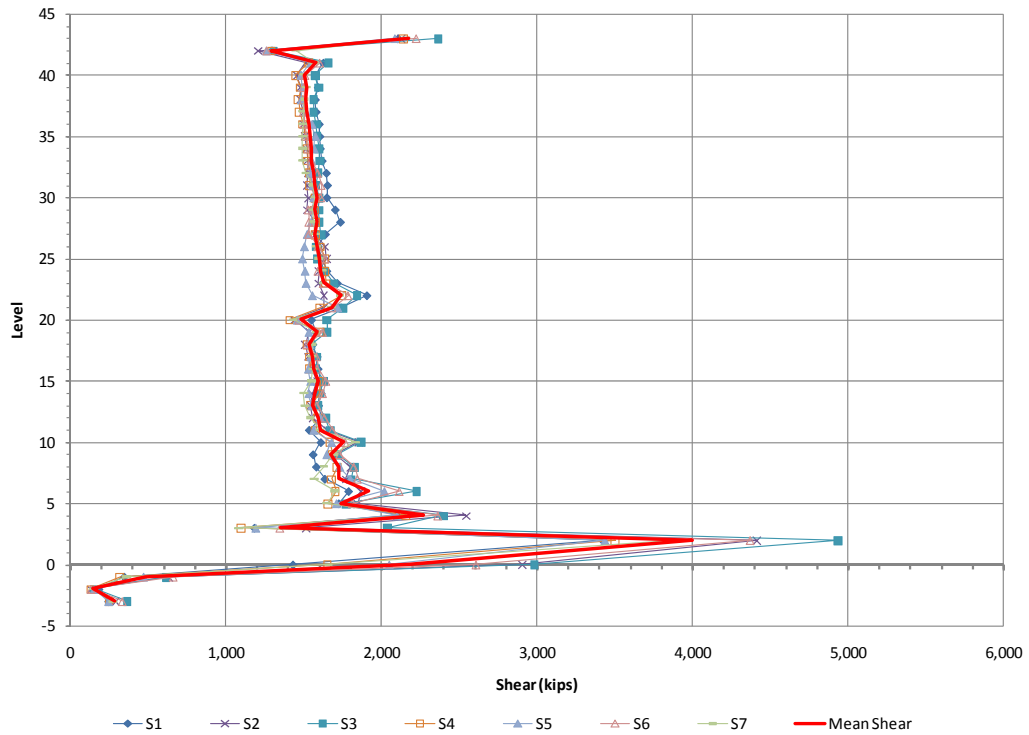

Figure 80 – Peak frame shear on X direction

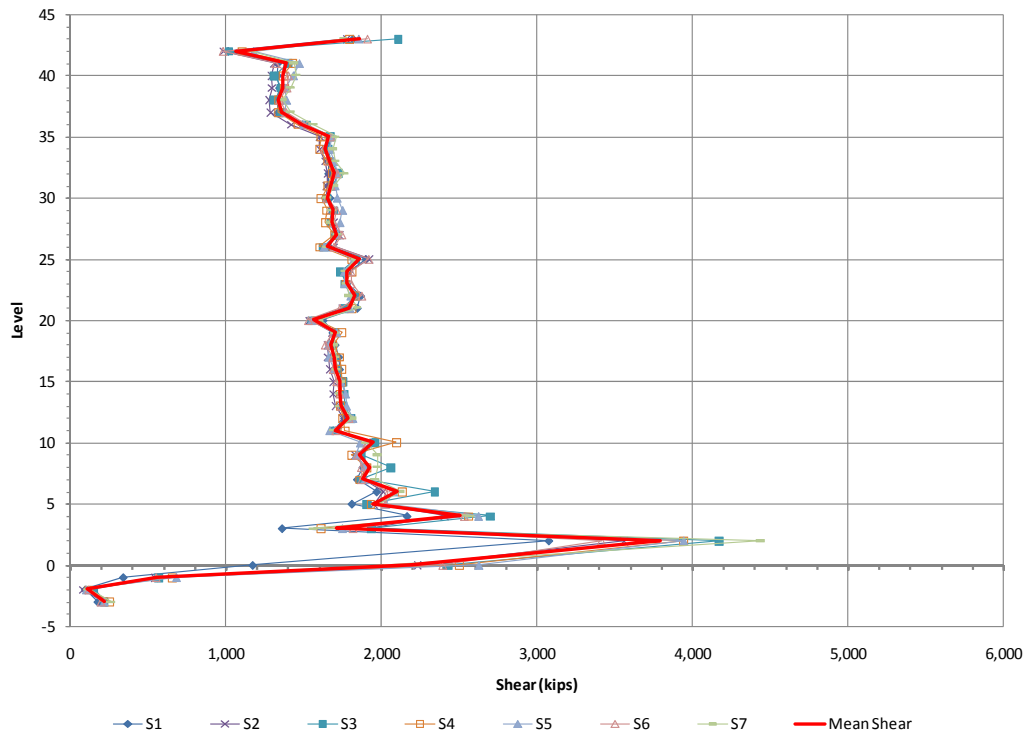

Figure 81 – Peak frame shear on Y direction

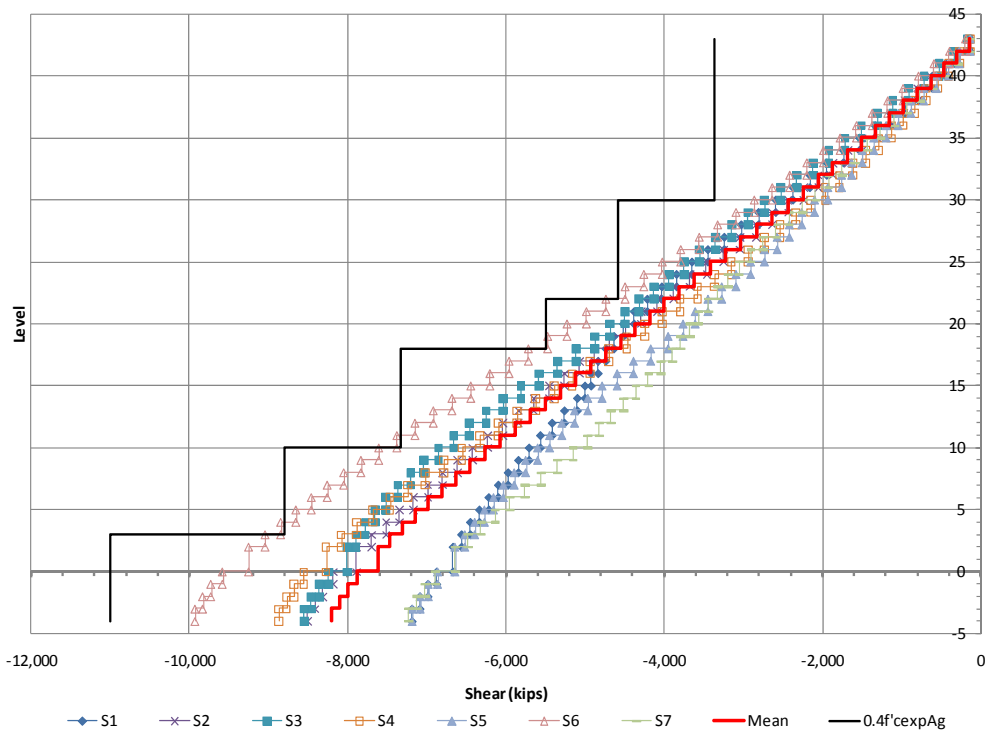

Figure 82 – Corner column peak compression

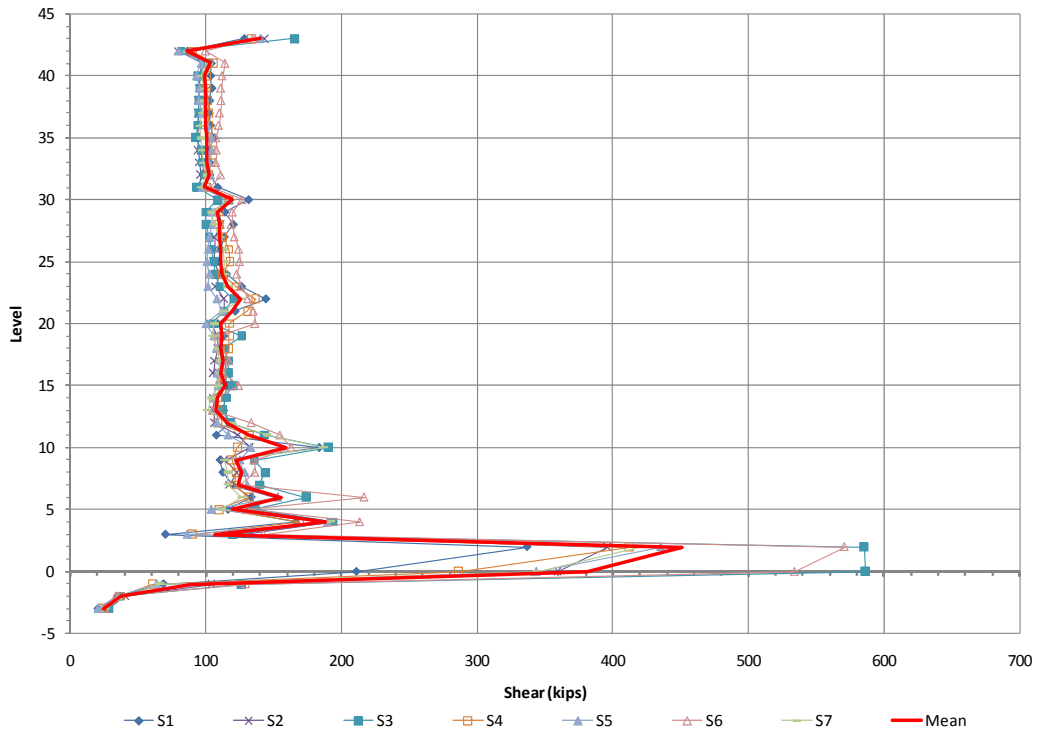

Figure 83 – Maximum shear on X direction at corner column on gridlines A-2

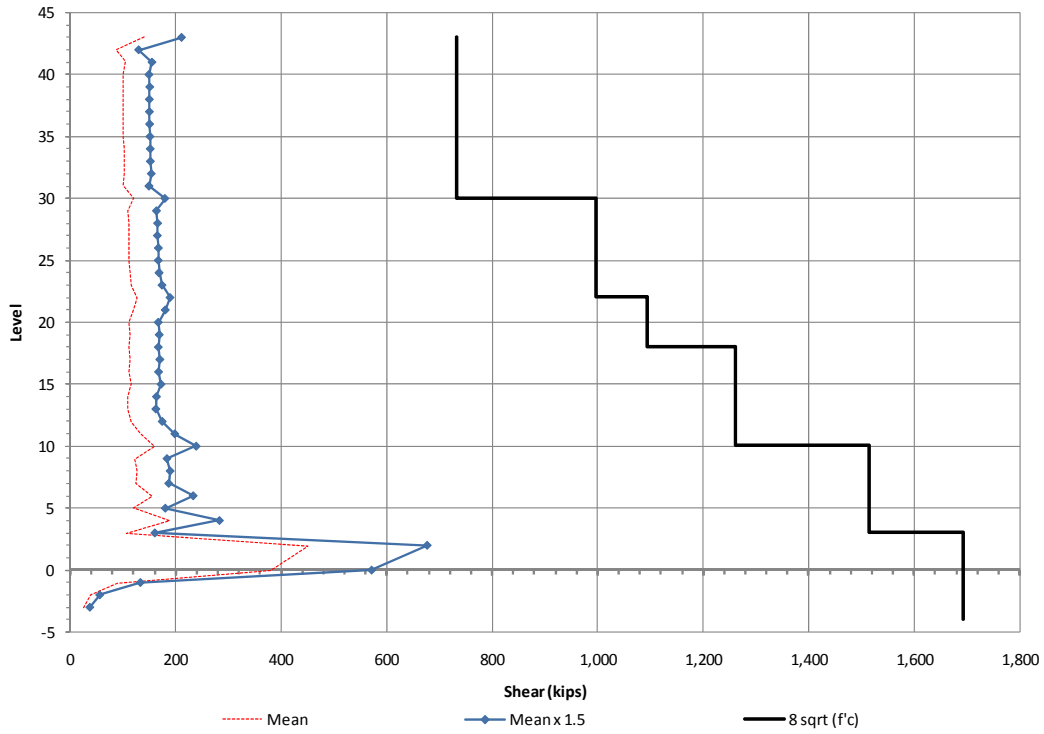

Figure 84 – Mean shear on X direction at corner column on gridlines A-2

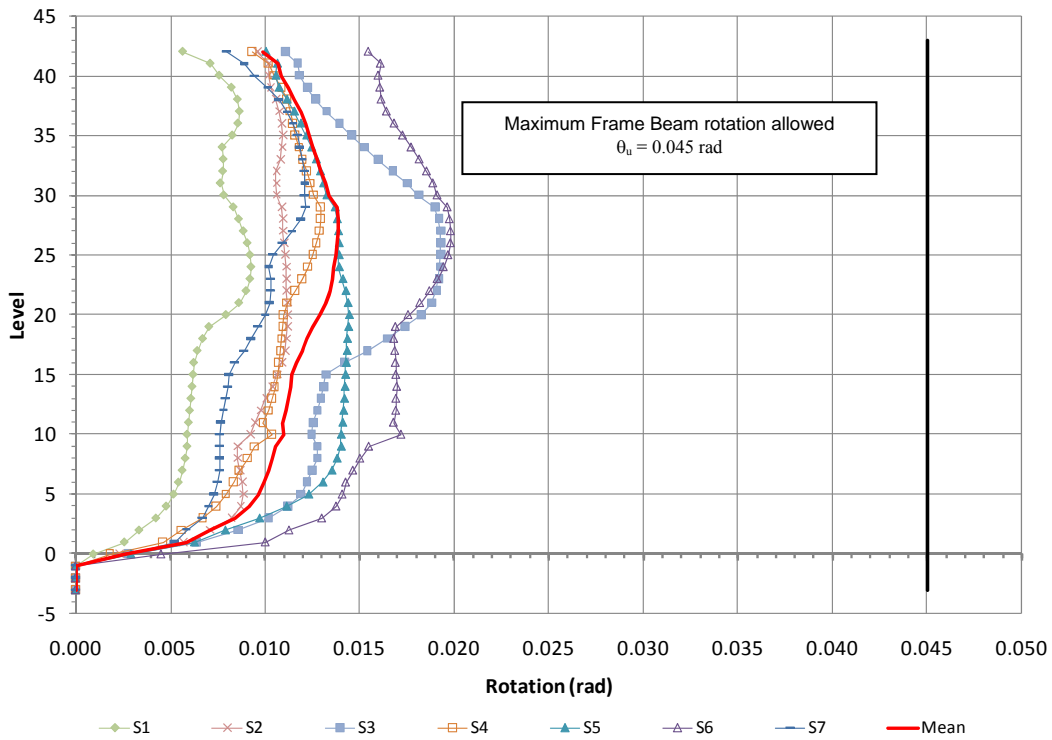

Figure 85 – Frame “A” beam rotation at face of column on gridlines A-2

4.3.4 Basement walls

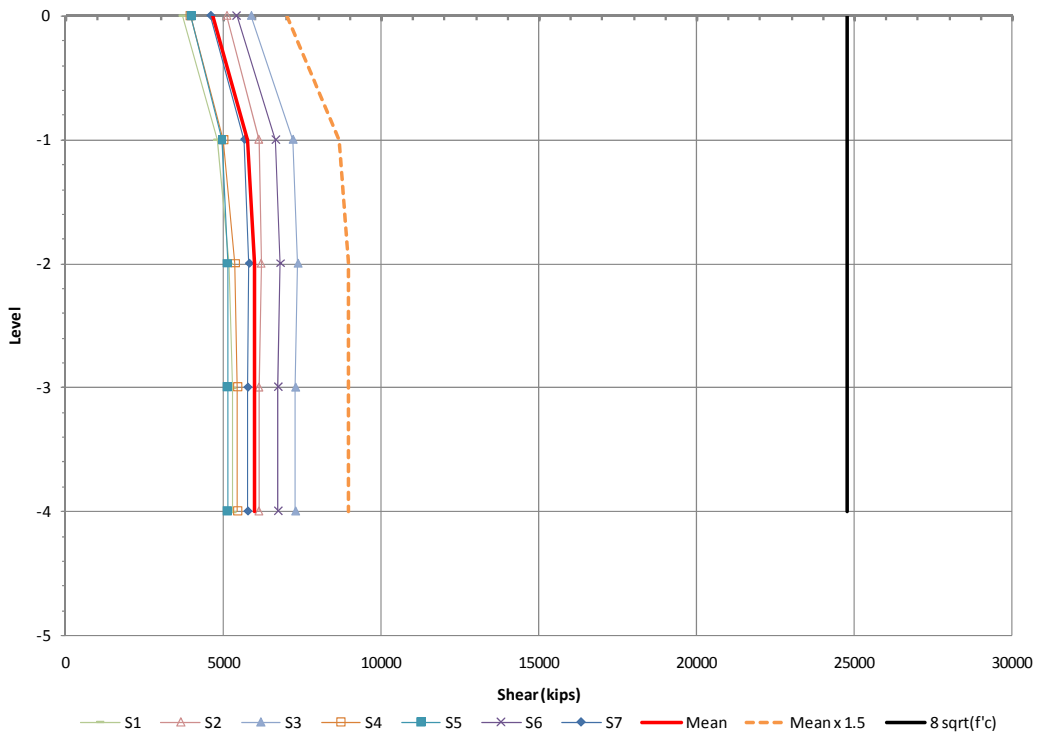

Figure 86 – Peak shear of basement wall on gridline Y1



References

1. ACI Committee 363 (1992). "State-of-the-Art Report on High-Strength Concrete (ACI 363-92)," *ACI Manual of Concrete Practice*, American Concrete Institute, Detroit, 2005.
2. ACI (2008). *ACI 318-08: Building Code Requirements for Structural Concrete with Commentary*, 2008 edition. American Concrete Institute, Farmington Hills, MI.
3. Adebar, P., Mutrie, J., and DeVall, R., (2004). Displacement-Based Design of Concrete Wall Buildings: The 2004 Canadian Code Provisions, *13th World Conference on Earthquake Engineering*, Vancouver, B.C.
4. ASCE (American Society of Civil Engineers) (2006). ASCE 7-05, *Minimum Design Loads for Buildings and Other Structures, Including Supplement No. 1*. American Society of Civil Engineers, Reston, VA.
5. E. P. Popov, V. V. Bertero and H. Krawinkler (1972). *Cyclic Behavior of Three R.C. Flexural Members with High Shear*, Report No. EERC 72-5, Earthquake Engineering Research Center, University of California, Berkeley, CA.
6. Englekirk Robert.E. (2003). *Seismic Design of Reinforced and Precast Concrete Buildings*. John Wiley & Sons, New York, NY.
7. Englekirk, Robert E. and Llovet, Dani (2000). *Cyclic Tests of Cast-in-Place High Strength Beam-Column Joints*, Carpenters/Contractors Cooperation Committee, Inc., *High Strength Concrete Research*, Los Angeles, CA.
8. ETABS Nonlinear Version 9.2.0 (2008). *Extended 3D Analysis of Building Structures*, Computers and Structures, Inc. Berkeley, CA.
9. ICC (International Code Council) (2006). *2006 International Building Code*, International Code Council, Falls Church, VA.
10. Los Angeles Tall Building Design Council (2008). *An Alternative Procedure for Seismic Analysis and Design of Tall Buildings Located in the Los Angeles Region*, Los Angeles, CA.
11. Mander, J.B., Priestley, M.J.N. and Park, R. (1988). "Theoretical Stress-Strain Model for Confined Concrete." *ASCE Journal of Structural Engineering*, 114 (8), 1804-1826.
12. Naish, David, Fry, Andy, Klemencic, Ron and Wallace, John. (2009). *Testing and Modeling of diagonally Reinforced Concrete Coupling Beams*. Paper submitted to ACI structural journal, Los Angeles, CA.
13. Orakcal, Kutay and Wallace, John W., (2006). *Flexural Modeling of Reinforced Concrete Walls – Experimental Verification*, ACI Structural Journal, V. 103, No. 2
14. Orakcal, Kutay, Wallace, John W. and Conte, Joel P., (2004). *Flexural Modeling of Reinforced Concrete Walls – Model Attributes*, ACI Structural Journal, V 101, No. 5
15. Paulay, T., and M.J.N. Priestley (1992). *Seismic Design of Reinforced Concrete and Masonry Buildings*. John Wiley & Sons, New York, NY.
16. Perform 3D Version 4.0.3 (2007). *Nonlinear Analysis and Performance Assessment of 3D Structures*, Computers and Structures, Inc. Berkeley, CA.



17. Powell, Graham H., (2007). *Detailed Example of a Tall Shear Wall Building Using CSI's Perform 3D Nonlinear Dynamic Analysis*, Computers and Structures Inc., Berkeley, CA.
18. SEAOC Seismology Committee (2008). "Reinforced concrete structures," September, 2008, *The SEAOC Blue Book: Seismic Design Recommendations*, Structural Engineers Association of California, Sacramento, CA. Accessible via the world wide web at: <http://www.seaoc.org/bluebook/index.html>
19. Wallace, John W., (2007). *Modeling Issues for Tall Reinforced Concrete Core Wall Buildings*, Published online by Wiley Interscience at: <http://www.interscience.wiley.com>

**Appendix C: Design Report for Building 3 --
Buckling-Restrained Braced Frame
Structural System**

DETAILED DESIGN WRITE-UP FOR BRBF BUILDING

Table of Contents

1.	Introduction	1-1
1.1	Purpose	1-1
1.2	Objective	1-1
1.3	Scope	1-2
1.4	Description of Project.....	1-2
1.5	Information Provided by Others	1-2
2.	Code-based Design	2-1
2.1	Purpose	2-1
2.2	Design Description.....	2-1
2.2.1	Gravity Analysis & Design	2-1
2.2.2	Lateral Analysis.....	2-2
2.2.3	Lateral Force Resisting Member Design	2-9
2.2.4	Story Drifts for Code Design.....	2-12
3.	PERFORMANCE BASED DESIGN.....	3-1
3.1	Service Level Earthquake Evaluation	3-1
3.2	Maximum Considered Earthquake Evaluation	3-3
3.2.1	Modeling of Critical Elements	3-4
3.2.2	Selected Results from Non Linear Analysis.....	3-9
4.	Enhanced PERFORMANCE BASED DESIGN.....	4-1
4.1	Service Level Earthquake Evaluation	4-1
4.1	Maximum Considered Earthquake Evaluation	4-4

LIST OF FIGURES

Figure 1:	Response Spectrum for Code Analysis	2-4
Figure 2:	Plan at Eleventh through Fortieth Floors	2-6

Figure 3: Elevation of Frame Along Line 2 Following Removal of a Brace.....	2-7
Figure 4: Elevation of Frame Along Line D Following Removal of a Brace	2-8
Figure 5: Defining Box Column Section Properties in ETABS	2-11
Figure 6: Response Spectrum for Serviceability Analysis.....	3-2
Figure 7: Presumed Backbone Curve for Buckling Restrained Braces	3-4
Figure 8: BRBF Property Definition in Perform.....	3-5
Figure 9: BRBF Compound Element in Perform.....	3-6
Figure 10: Column Section Definition in Perform.....	3-7
Figure 11: Column Strength Definition in Perform	3-8
Figure 12: Peak Interstory Drifts in the Y Direction.....	3-9
Figure 13: Peak Interstory Drifts in the X Direction.....	3-10
Figure 14: BRBF Core Strain DCRs along Lines 2, 3 and 4	3-11
Figure 15: BRBF Core Strain DCR Along Line D.....	3-12
Figure 16: Seismic Frame Column Axial Flexure Interaction Ratio along Line E	3-13
Figure 17: Accumulated Peak Story Shear in Steel Superstructure in Y Direction.....	3-14
Figure 18: Accumulated Peak Story Shear in Steel Superstructure in X Direction.....	3-15
Figure 19: Response Spectrum for Enhanced PBE.....	4-1
Figure 20: 3D Computer Model used for the Enhanced Performance Based Evaluation	4-2
Figure 21: Peak Interstory Drifts in the Y Direction.....	4-5
Figure 22: Peak Interstory Drifts in the X Direction.....	4-6

1. INTRODUCTION

1.1 Purpose

This report presents the design basis for two alternative designs of a 39-story steel framed office building located at a generic site in Los Angeles, California. One of these designs, termed the code-based design conforms in all respects, except one, with the design criteria contained in the following codes and standards:

- 2007 California Building Code
- ASCE 7.05 Standard for Minimum Design Loads for Buildings and Other Structures
- AISC 360.05 Specification for Steel Buildings
- AISC 341.05 Seismic Specification
- ACUI 318-08 Building Code Requirements for Reinforced Concrete

The one exception to the requirements of these codes and standards is that the design does not have a backup special moment-resisting frame as required by ASCE 7.05 for structures with a height in excess of 160 ft.

The second design has been conducted using a performance-based approach generally based on the criteria contained in a document published by the Los Angeles Tall Buildings Council.

1.2 Objective

Simpson Gumpertz & Heger, Inc. developed the two designs presented in this report on behalf of the Pacific Earthquake Engineering Research Center (PEER) under its Tall Buildings Initiative (TBI). The objective of the TBI is to develop recommended performance-based design criteria for tall buildings as an alternative to the criteria contained in present building codes and standards. These alternative performance-based criteria are intended to provide performance that is at least equivalent to that intended for buildings designed in conformance with the code. The buildings presented in this report, together with designs using other structural systems developed by other designers, will be used by PEER to assess the cost and performance capability of buildings designed using alternative design approaches and criteria. This information will guide the development of the PEER recommendations.

1.3 Scope

Our scope of work included the following:

1. Meet with representatives of PEER and other design consultants engaged in the TBI project to develop the general criteria for the designs.
2. Develop a design, to a schematic level, for an essentially code-conforming steel-framed building
3. Develop a design, to a schematic level, for a performance-based steel framed building, of similar height and footprint, using the procedures contained in design recommendations prepared by the Los Angeles Tall Buildings Council.
4. Prepare schematic level drawings documenting the design
5. Prepare this design report

1.4 Description of Project

Both designs have typical above-grade floors comprised of lightweight concrete fill on metal deck supported by composite steel framing with a foot print of 170 ft by 107 ft. Both designs have four basement levels with a foot print of 227 ft by 220 ft. Both structures have lateral force resisting systems comprised of buckling-restrained braced frames.

1.5 Information Provided by Others

The Pacific Earthquake Engineering Research Center provided geotechnical/seismicity data for the hypothetical site including:

- Code spectral response acceleration coefficients – S_s and S_1
- Site Class
- Ground motion records for use in analysis
- General loading criteria

2. CODE-BASED DESIGN

2.1 Purpose

This section provides a brief overview of the code based design. As discussed in the Design Criteria, we used the International Building Code 2006 to perform this design.

2.2 Design Description

This design was conducted in conformance with all the prescriptive provisions of the International Building Code 2006, and its referenced standards, except for the limitation on the building height. The International Building Code would require that buildings in excess of 160 ft and located on the site selected for this building be provided with a special moment-resisting frame capable of resisting at least 25% of the specified design seismic forces. This design did not incorporate such a frame. Salient features of this design are provided in the following sections.

2.2.1 Gravity Analysis & Design

We designed the building's vertical-load resisting system using gravity loads that consist of a combination of self weight of the elements and additional superimposed loads. Based on the design criteria document provided to us by PEER, we considered the following superimposed loads at various floors in addition to the self weight.

Table 1 – Gravity Loading Criteria

Description/Location	Superimposed Dead	Live Load	Reducability
Roof	28 psf	25 psf	Yes
Mechanical, Electrical at Roof	Total of 100 kips	-	-
Residential including Balconies	28 psf	40 psf	Yes
Corridors, Lobbies and Stairs	28 psf	100 psf	No
Retail	110 psf	100 psf	No
Parking Garage, Ramp	3 psf	40 psf ¹	Yes
Construction Loading	3 psf	30 psf	No
Cladding	15 psf	-	-

1. PEER document showed 50 psf. SGH considered 40 psf in keeping with ASCE 7-05.

We combined the element self weights with the superimposed loading from the above table and performed a gravity-load design using the RAM Structural System software, version 12.1. We have included a complete flat load table in Appendix A (Pages A1 through A4) for reference. In those tables the highlighted cells add up to the superimposed loads shown in Table 1.

2.2.2 Lateral Analysis

Following design of the vertical-load carrying elements, we performed a lateral analysis of the building. We considered both wind and seismic forces and designed each element for the most severe requirements. A brief description of the wind and seismic design is given below.

2.2.2.1 Wind Analysis

We used ASCE 7-05, Method 2 for calculating the wind pressures. Table 2 lists the various parameters used for calculating the wind pressure.

Table 2 – Wind Design Criteria

Parameter	Value
Basic Wind Speed, 3 sec. gust (V)	85 mph
Basic Wind Speed, 3 sec gust (V), for serviceability wind demands based on a 10 year mean recurrence interval	67 mph
Exposure	B
Occupancy Category	II
Importance Factor (I_w)	1.0
Topographic Factor (K_{zt})	1.0
Exposure Classification	Enclosed
Internal Pressure Coefficient (GC_{pi})	± 0.18
Mean Roof Height (h)	544'-6"
Wind Base Shear along Two Orthogonal Directions	1436 kips and 2629 kips

We considered the four cases depicted in Figure 6-9 of ASCE 7-05. Each of these cases includes the direct wind force in each orthogonal direction either alone or in combination with story torsional moment caused by the eccentric application of this load.

We calculated the gust effect factor (G_f) following Section 6.5.8.2 of ASCE 7-05 for flexible or dynamically sensitive structures for 1% damping.

We have included the details of the wind analysis in Appendix A pages A5 through A10. Page A5 shows the calculation of the gust effect factor for the short normal (East West) direction of the building. Page A6 shows the calculation of the wind pressure for the same direction over the height of the building. Page A7 shows the story forces and story moments. Pages A8 through A10 show the identical quantities in the long normal (North South) direction of the building.

2.2.2.2 Seismic Analysis

We used linear response spectrum analysis to calculate seismic forces and displacements. Per ASCE 7-05, Cl 12.9.4, we scaled the forces to 85% of the base shear obtained from the equivalent lateral force procedure of Cl 12.8. Table 3 lists the various parameters that we used for the seismic design.

Table 3 – Seismic Design Parameters

Parameter	Value
Building Latitude/Longitude	Undefined
Occupancy Category	II
Importance Factor (I_e)	1.0
Spectral Response Coefficients	$S_{DS} = 1.145$; $S_{D1} = 0.52$
Seismic Design Category	D
Lateral System	Buckling restrained braced frames, non moment resisting beam column connections
Response Modification Factor (R)	7
Deflection Amplification Factor (C_d)	5.5
System Overstrength Factor (Ω_0)	2.0
Building Period (T) using Cl. 12.8.2	3.16 sec ¹
Seismic Response Coefficient C_s (Eq. 12.8-1)	0.051 W (Governed by C_{s-min} from Eq. 12.8-5)
Scaled Spectral Base Shear	3504 kips (85% of Static Base Shear)
Analysis Procedure	Modal Response Spectral Analysis
1. Actual period from dynamic model: $T_Y = 5.05$ sec; $T_X = 3.62$ sec	

We performed the lateral analysis using the program ETABS, version 9.5.0. Page A11 of the appendix A shows the modal information for the first 50 modes of the code model.

We used the 5% damped, acceleration response spectrum shown in Figure 1. We included sufficient modes to obtain participation of at least 90% of the structure's mass. We scaled the results of the response spectrum analysis such that the base shear immediately above the ground floor matched 85% of the static base shear from the equivalent static force analysis. Page A12 of the appendix shows the distribution of the static lateral force F_x and the diaphragm design force F_{px} . The last columns of the same sheet shows the mass and mass moment of inertia used in the model at various floors. Note that for levels below the ground floor, the mass of the perimeter walls are automatically calculated by the program.

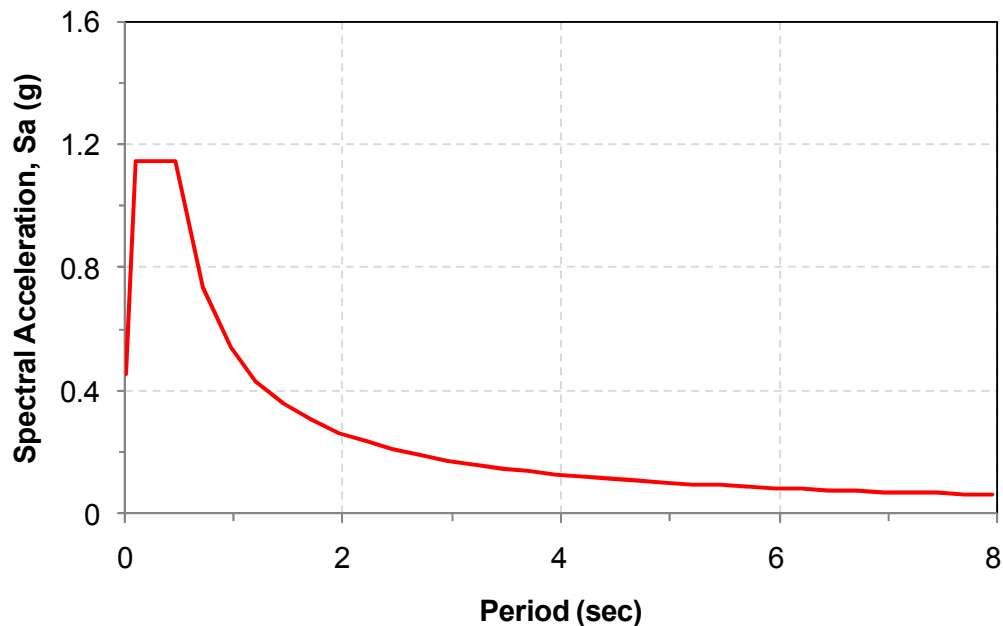

Figure 1: Response Spectrum for Code Analysis

IBC 2006 also requires the designer to calculate the redundancy factor (ρ) for seismic design. We calculated the redundancy factor per 12.3.4.2 of ASCE 7-05. According to that section, a building will qualify for a $\rho = 1$ provided that the removal of an individual brace or connection will not result in more than a 33% reduction in story strength, nor will the resulting system have an extreme torsional irregularity. Extreme torsional irregularity is defined to exist when the maximum story drift computed including accidental torsion, at one end of the structure

transverse to an axis is more than 1.4 times the average story drifts at the two ends of the structure.

In order to calculate the redundancy factor when the seismic forces are acting in the North South direction, we removed a brace from line 2 along the full height of the building. We then subjected the building to the static lateral forces along with the 5% accidental torsion. We term these forces as EQYPL (with the accidental eccentricity towards the positive right) and EQYMN (with the accidental eccentricity towards the negative left). Since the building has at least 6 bays of braced frame in each principal direction, loss of a brace or connection will never reduce the capacity by 33%. We found that that for the North South direction, the largest ratio of maximum story drift over the average drift over the height of the building was 1.39 at Story 13 (see page A12). Since this is less than 1.4, we concluded that the redundancy factor in the North South direction is 1. Figure 2 shows the plan view of the tower and Figure 3 shows the elevation at Line 2 after the removal of the brace.

We also performed a similar analysis in the X (East West direction). In this model we removed a single brace from Line D and subjected the building to static forces EQXPL ((with the accidental eccentricity towards the positive top) and EQXMN (with the accidental eccentricity towards the negative bottom). Figure 4 shows the elevation of the frame along Line D with the brace removed. We then calculated the ratio of maximum to average drifts and obtained ratios ranging from 1.468 to 1.408 from roof to Story 36. However, section 12.3.4.2 stipulates that this ratio should strictly be studied for floors resisting more 33% of the base shear which is numerically equal to 1156 kips. This only happens below Story 35 (see page A13). We found that the ratio of maximum to average drift is only marginally greater than 1.4 at two stories with a maximum value of 1.408 at Story 34 (D/C of 1.008). We arbitrarily declared that this met the requirements of ASCE-7 for a redundancy coefficient, $\rho=1$.

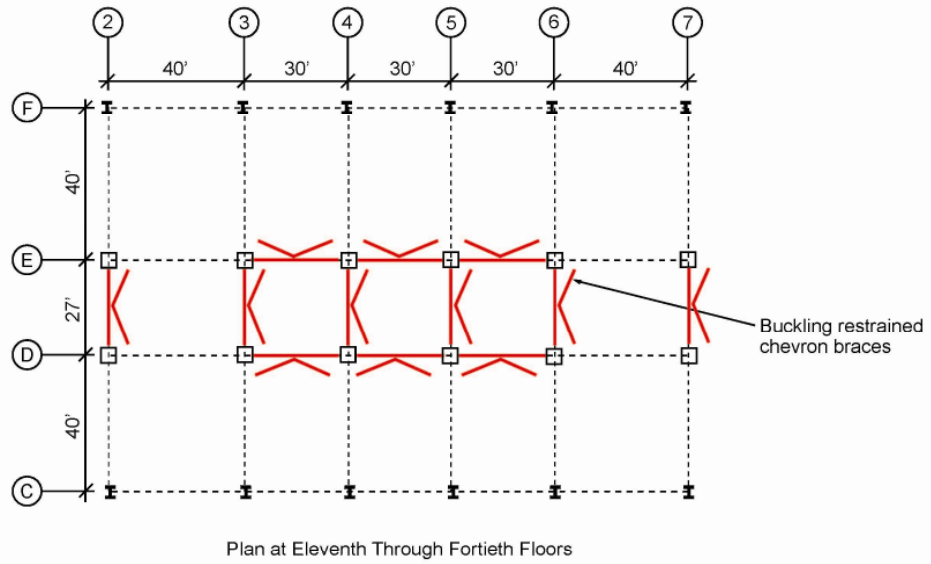

Figure 2: Plan at Eleventh through Fortieth Floors

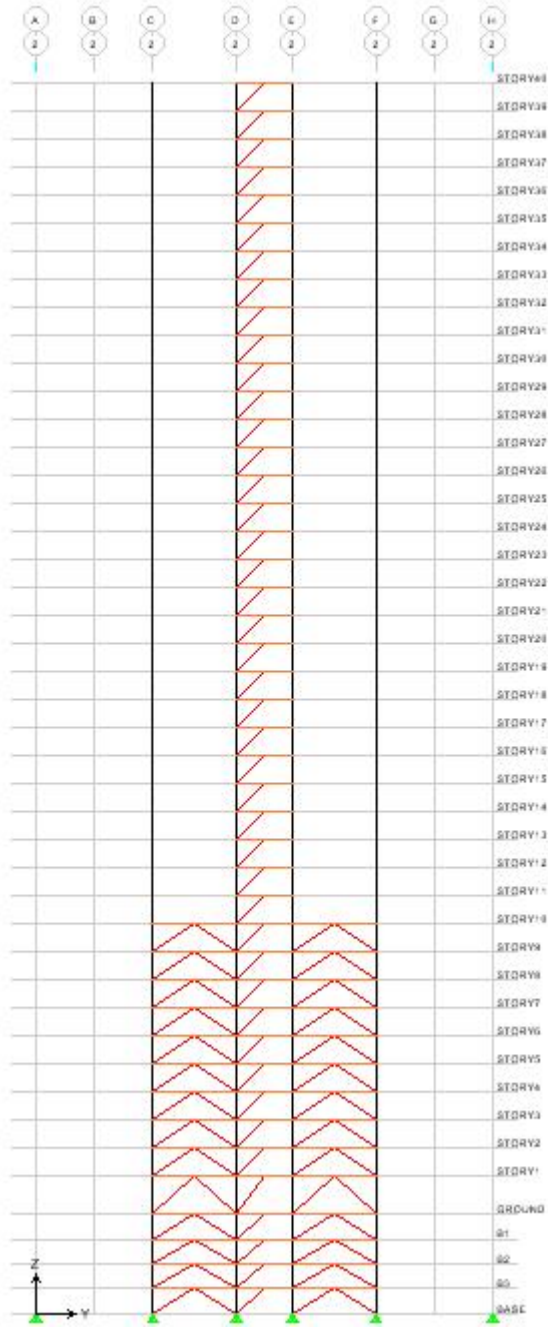

Figure 3: Elevation of Frame Along Line 2 Following Removal of a Brace

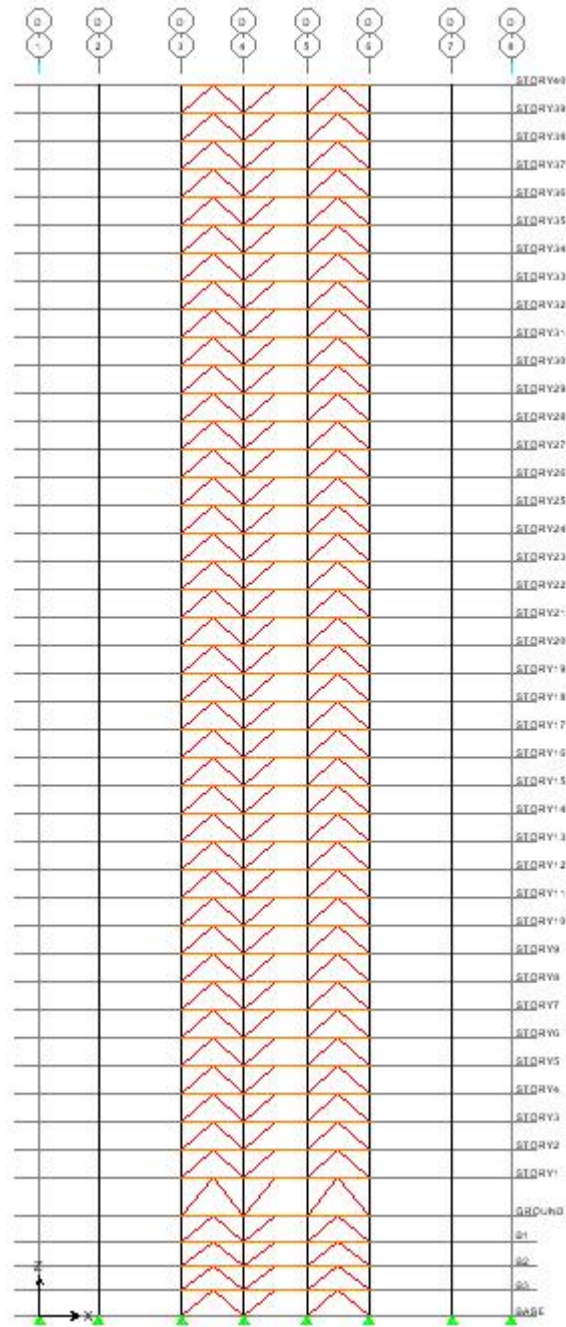

Figure 4: Elevation of Frame Along Line D Following Removal of a Brace

2.2.3 Lateral Force Resisting Member Design

2.2.3.1 Buckling Restrained Brace Design

We designed the buckling restrained braces for the worst of the wind and seismic loads. In almost all cases, seismic loads governed the design. The capacity of the braces in tension and compression was both considered as $\phi A_s F_y$, with $\phi = 0.9$ and $F_y = 38$ ksi. Pages A14 through A37 show the brace design details along lines 2, 3, 4 and D respectively.

2.2.3.2 Braced Frame Column Design

AISC's Seismic Provisions for Structural Steel Buildings (ANSI/AISC 341-05), require columns in buckling restrained braced frames need to be checked for

- Axial load and moment interaction for code level forces
- For axial load only corresponding to the sum of the vertical component of all buckling restrained braces that frame into the column along with tributary gravity loading

We checked the columns for both of the above criterion and found that the latter generally produced larger D/C ratios. Since the current configuration uses columns that form part of lateral framing in two orthogonal directions, we used the 100%-30% combination to calculate the maximum compression from the braces. We established the maximum compression forces from the brace as $R_y \omega \beta A_s F_y$, where $R_y = 1.1$, $\omega = 1.25$ and $\beta = 1.1$.

We used built up square box columns infilled with high strength ($f'_c = 10$ ksi) concrete to resist the large compression force demands. The plate thicknesses of the box columns ranged from 1.5 in. at upper stories to 3 in. at lower ones. The plan dimension of the box columns ranged from 18 in. to 57 in. We calculated the strength, axial area and stiffness of infill columns using the provisions of Chapter I (Design of Composite Members) of the 13th edition LRFD Steel Code. We included this enhancement of axial area and stiffness over the bare steel section properties in the ETABS analysis model as well. We did this by defining a steel box section in ETABS and then using the property modifier to account for the infill concrete. Figure 5 shows the ETABS screen shot of how this is accomplished. Page A38 shows the detailed strength and stiffness calculation for the box columns. Note that the last two columns calculate the axial and inertial modifiers used in ETABS. Additionally pages A39 through A41 show the details of the column design at C/2, D/2 and D/3 respectively.

2.2.3.3 Braced Frame Beam Design

We designed the braced frame beams for the horizontal component of the brace compression along with unbalanced upward component of the buckling restrained brace given by $R_y \omega A_s F_y (\beta - 1) \sin \alpha$ where α is the brace angle. Since BRBs are always stronger in compression than tension, this moment is opposite in direction to the gravity moment. Page A42 shows a sample beam design for the frame along line 2.

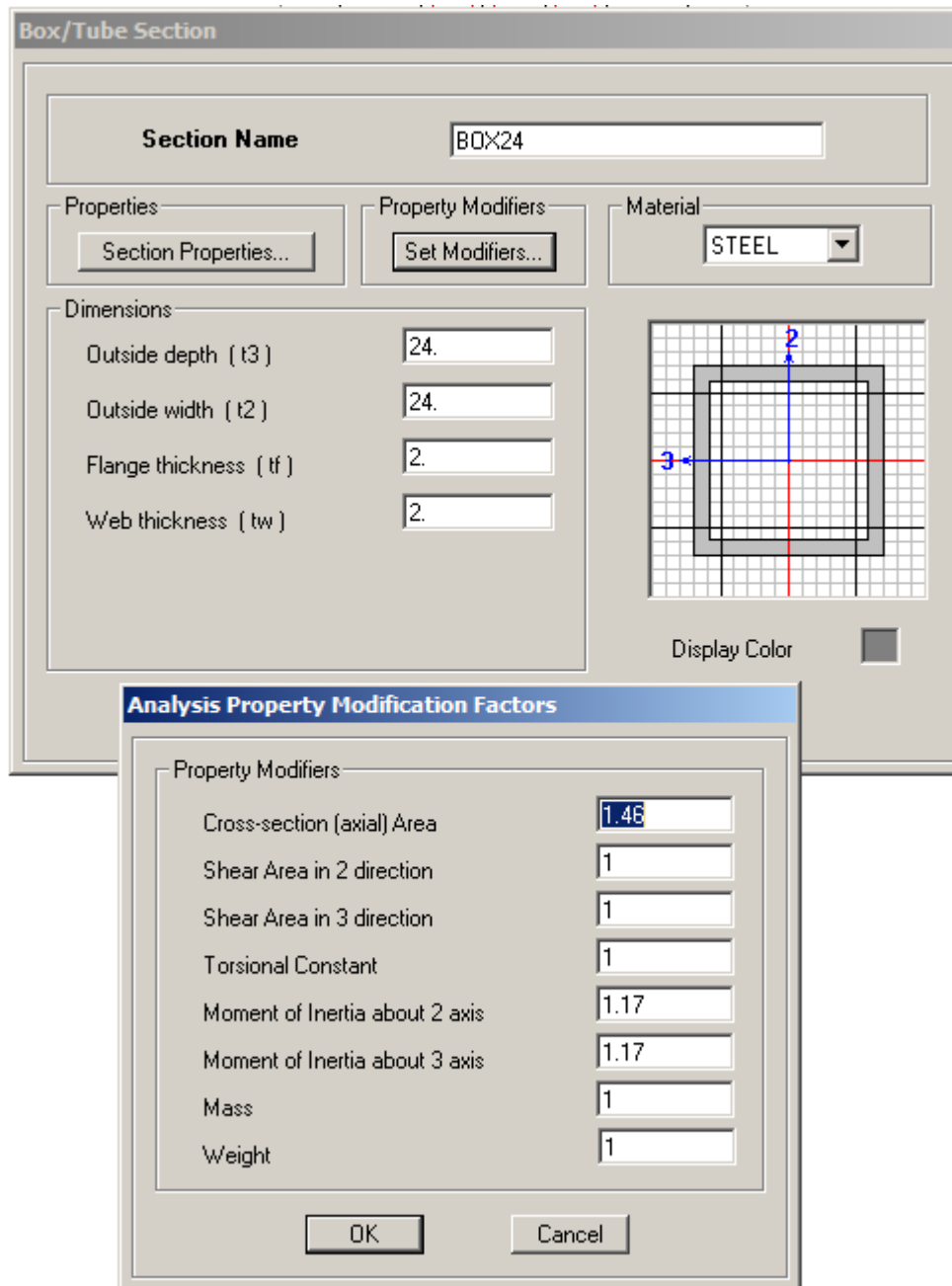

Figure 5: Defining Box Column Section Properties in ETABS

2.2.4 Story Drifts for Code Design

We calculated interstory drifts using the response spectrum analysis. ASCE 7-05 stipulates the use of a response spectrum that is reduced by the response reduction factor, R . It also states that the drifts obtained from this reduced spectral analysis be amplified by C_d to yield the expected inelastic drifts. Table 4 shows the interstory drifts obtained at the various levels both for the X and Y directions. As can be seen, the maximum story drifts are less than the permissible value of 0.02 at all levels.

Table – 4 Story Drifts for Code Design

Story	Y Direction Drifts	X Direction Drifts
Story 40	0.013	0.005
Story 39	0.014	0.006
Story 38	0.014	0.006
Story 37	0.014	0.006
Story 36	0.014	0.006
Story 35	0.014	0.006
Story 34	0.014	0.006
Story 33	0.014	0.006
Story 32	0.014	0.006
Story 31	0.014	0.006
Story 30	0.014	0.006
Story 29	0.014	0.006
Story 28	0.014	0.006
Story 27	0.013	0.006
Story 26	0.013	0.006
Story 25	0.013	0.006
Story 24	0.013	0.006
Story 23	0.012	0.006
Story 22	0.012	0.006
Story 21	0.012	0.006
Story 20	0.012	0.006
Story 19	0.011	0.006
Story 18	0.011	0.006
Story 17	0.011	0.006

Story	Y Direction Drifts	X Direction Drifts
Story 16	0.010	0.006
Story 15	0.010	0.006
Story 14	0.010	0.005
Story 13	0.009	0.005
Story 12	0.008	0.005
Story 11	0.007	0.005
Story 10	0.004	0.004
Story 9	0.004	0.004
Story 8	0.004	0.004
Story 7	0.004	0.004
Story 6	0.004	0.004
Story 5	0.004	0.004
Story 4	0.003	0.004
Story 3	0.003	0.004
Story 2	0.003	0.003
Story 1	0.002	0.002

3. PERFORMANCE BASED DESIGN

We based the seismic design for this alternate on the seismic design criteria (dated 29 April 2008) published by the Los Angeles Tall Building Structural Design Council (LATBSDC). Since this design was not required to meet all of the prescriptive criteria contained in the building code, we were able to reduce the size and number of bays of the buckling restrained frames. Specifically, along lines 2 and 7 the two additional bays below level 10 were omitted and only a single bay of bracing is provided. Table 6 lists the performance objectives we followed for this design:

Table 6 – Seismic Performance Objectives

Level of Earthquake	Earthquake Performance Objectives
Frequent/Service : 25 year return period, 2.5% damping	Serviceability: Essentially elastic performance with minor yielding of brbf-s. Drift limited to 0.5%
Maximum Considered Earthquake (MCE): As defined by ASCE 7-05, Section 21.2, 2.5% damping.	Collapse Prevention: Extensive structural damage, repairs are required and may not be economically feasible. Drift limited to 3%

3.1 Service Level Earthquake Evaluation

We used a response spectrum analysis for this evaluation. We used the response spectrum shown in Figure 6, which was provided by PEER. The damping level was set at 2.5%. We neglected accidental torsion in this analysis.

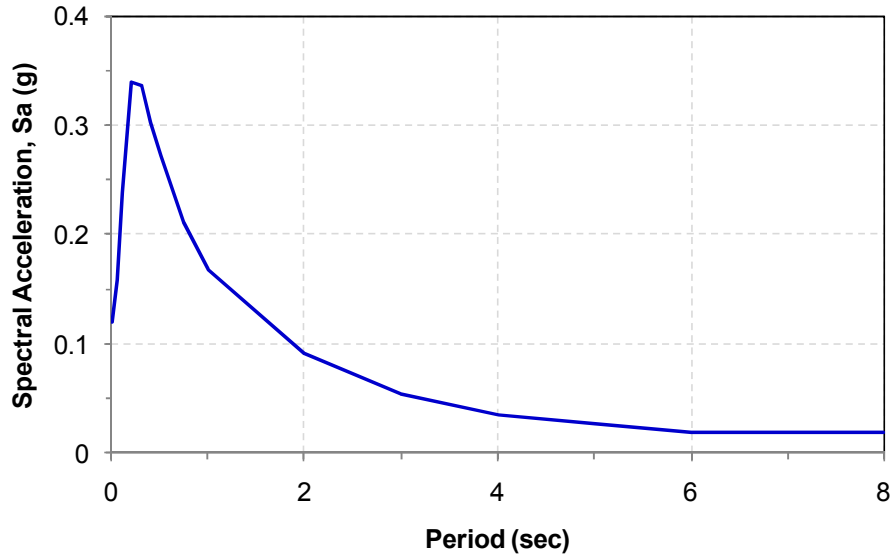

Figure 6: Response Spectrum for Serviceability Analysis

We also evaluated the building for the same wind forces that we used for the code-based design described in the previous section. We found that wind always governed the required brace strength. Pages A43 through A48 show the representative details of the brace design along line 3. The interstory drifts for the service level earthquake is shown in the following table. As can be seen, the drifts are less than 0.5% at all levels.

Table 4 – Story Drifts for Service Level Earthquake

Story	Y Direction Drifts	X Direction Drifts
Story 40	0.0031	0.0014
Story 39	0.0032	0.0015
Story 38	0.0033	0.0016
Story 37	0.0033	0.0017
Story 36	0.0034	0.0017
Story 35	0.0033	0.0018
Story 34	0.0033	0.0018
Story 33	0.0033	0.0018
Story 32	0.0032	0.0018
Story 31	0.0031	0.0018
Story 30	0.0031	0.0018
Story 29	0.0029	0.0018

Story	Y Direction Drifts	X Direction Drifts
Story 28	0.0028	0.0018
Story 27	0.0027	0.0018
Story 26	0.0026	0.0018
Story 25	0.0026	0.0018
Story 24	0.0025	0.0018
Story 23	0.0024	0.0018
Story 22	0.0023	0.0018
Story 21	0.0022	0.0017
Story 20	0.0021	0.0017
Story 19	0.0021	0.0017
Story 18	0.002	0.0017
Story 17	0.002	0.0017
Story 16	0.0019	0.0017
Story 15	0.0019	0.0016
Story 14	0.0018	0.0016
Story 13	0.0018	0.0016
Story 12	0.0017	0.0016
Story 11	0.0017	0.0016
Story 10	0.0016	0.0017
Story 9	0.0016	0.0017
Story 8	0.0016	0.0017
Story 7	0.0015	0.0017
Story 6	0.0015	0.0017
Story 5	0.0015	0.0017
Story 4	0.0014	0.0017
Story 3	0.0014	0.0016
Story 2	0.0012	0.0014
Story 1	0.0008	0.001

3.2 Maximum Considered Earthquake Evaluation

As required by the LATBSDC document, we performed a non linear response history analysis of the building corresponding for maximum considered earthquake shaking as defined by the building code. We used seven pairs of acceleration histories provided to us by PEER for this

purpose. We used the non linear analysis program CSI Perform, version 4.0.1 with a constant modal damping level of 2.5% and 0.1% Rayleigh damping. We explicitly modeled the non linearities in the buckling restrained braces. We modeled columns and beams as elastic elements and later verified that demands on these elements remained within their elastic capacities. Details of the element modeling are discussed below.

3.2.1 Modeling of Critical Elements

3.2.1.1 Modeling of Buckling Restrained Braces

We modeled the buckling restrained braces (brb) using the perform BRB inelastic element in series with an elastic spring that models the end attachment of the braces. The backbone curve of the BRBs were modeled according to Figure 7 with $R_y = 1.1$, $\omega = 1.25$ and $\beta = 1.1$. Figure 8 shows the screen shot of the Perform input form for the BRB definition and Figure 9 shows the form for the compound element definition with the elastic end element in series. Note that the initial stiffness (K_0) of the buckling restrained brace is based on $A_s E/L$ with L equal to 70% of the actual center to center length of the brace.

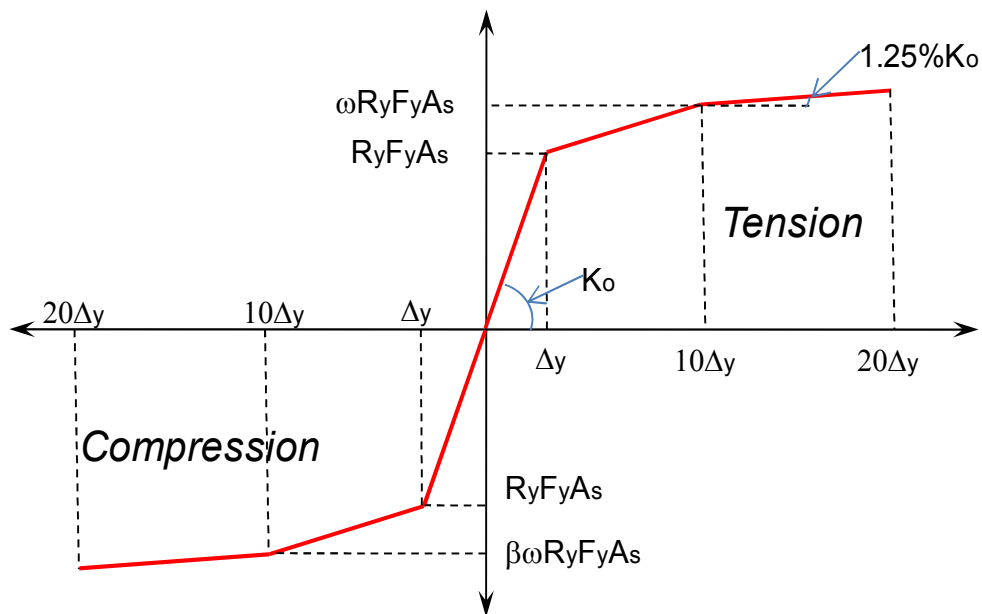

Figure 7: Presumed Backbone Curve for Buckling Restrained Braces

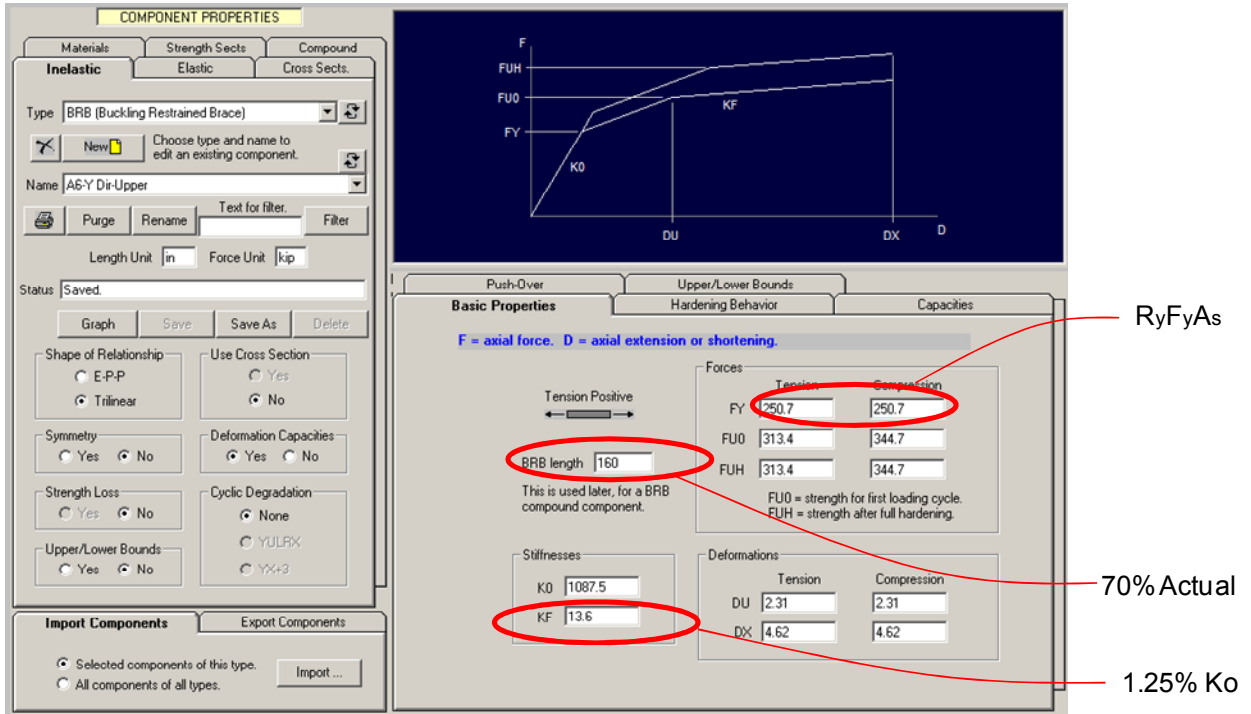

Figure 8: BRBF Property Definition in Perform

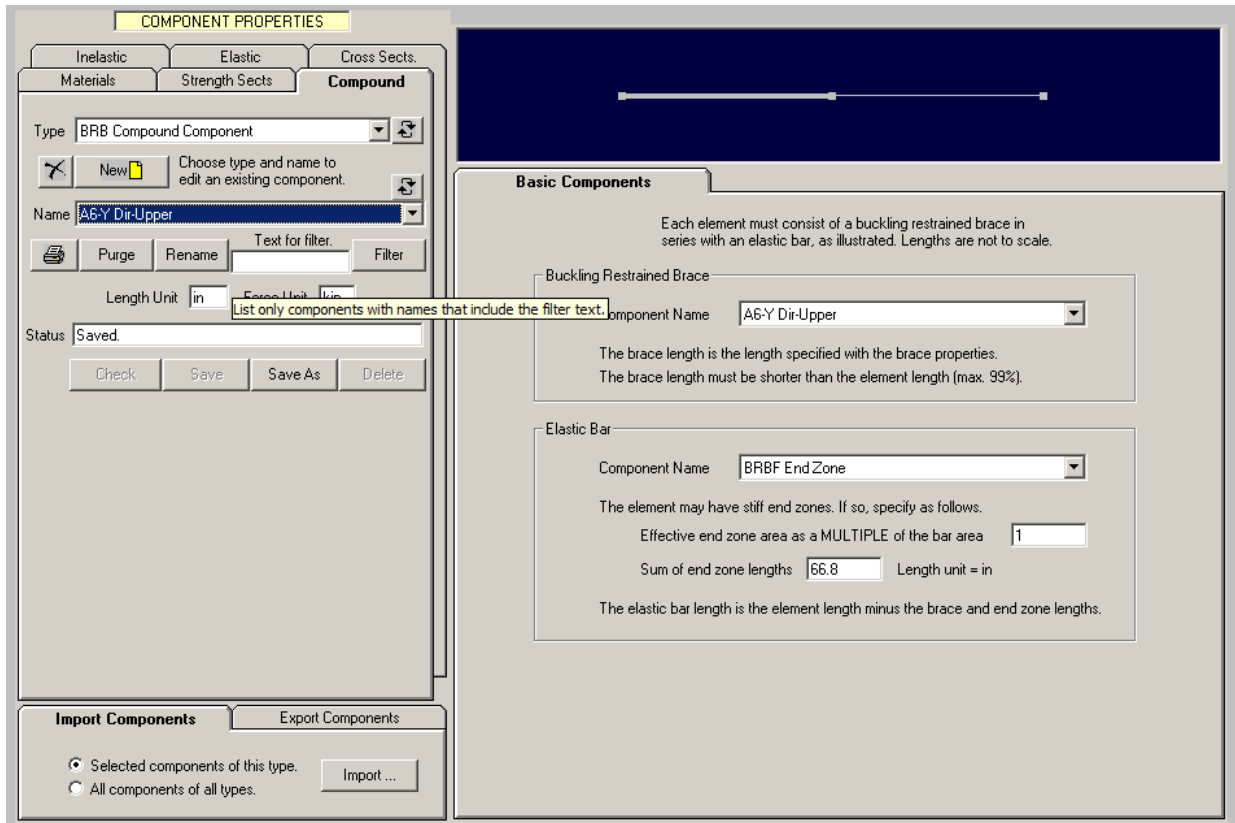

Figure 9: BRBF Compound Element in Perform

3.2.1.2 Modeling of the Columns and Beams

We modeled the columns using the non prismatic steel sections in Perform. The moment of inertia input in the form was adjusted to account for the additional stiffening due to the presence of the infill concrete. Figure 10 shows the stiffness and area definition form for the 48 sq in. box columns with 3 in. plates.

The axial load and moment strength for the same column is shown in Figure 11. The axial and flexural strengths are corresponding to nominal material properties without any strength reduction or ϕ factor.

The compound column element utilizes the cross sectional information and assembles the column element as an elastic element. We have ensured that the column element always stays elastic during the analysis by monitoring the axial flexure interaction ratios so that they are always less than 1.

Beams are modeled in an identical fashion as the columns except that standard *W* sections are used. Similar to the columns, the beams are also modeled as elastic elements.

COMPONENT PROPERTIES

Materials | Strength Sects | Compound

Inelastic | Elastic | **Cross Sects.**

Type: Column, Steel Type, Nonstandard Section

Choose type and name to edit an existing section.

Name: Box 48

Length Unit: in | Force Unit: kip

Status: Saved.

Symmetry: Yes No

Import Components | Export Components

Selected components of this type.

All components of all types.

Stiffness, Dimensions | Inelastic Strength | Elastic Strength

Shape and Dimensions

Section Shape: No specific shape

B: 0 | D: 0

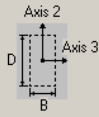

To calculate the section properties for the above dimensions, press this button. If you wish, you can edit the properties after they have been calculated.

Section Stiffness

Axial Area	<input type="text" value="891"/>	Torsional Inertia	<input type="text" value="273375"/>
Shear Area along Axis 2	<input type="text" value="288"/>	Bending Inertia about Axis 2	<input type="text" value="230655.6"/>
Shear Area along Axis 3	<input type="text" value="288"/>	Bending Inertia about Axis 3	<input type="text" value="230655.6"/>

Shear area = 0 means no shear deformation.

Material Stiffness

Young's Modulus	<input type="text" value="29000"/>	Poisson's Ratio	<input type="text" value="0.3"/>	Shear Modulus =	<input type="text" value="11154"/>
-----------------	------------------------------------	-----------------	----------------------------------	-----------------	------------------------------------

Figure 10: Column Section Definition in Perform

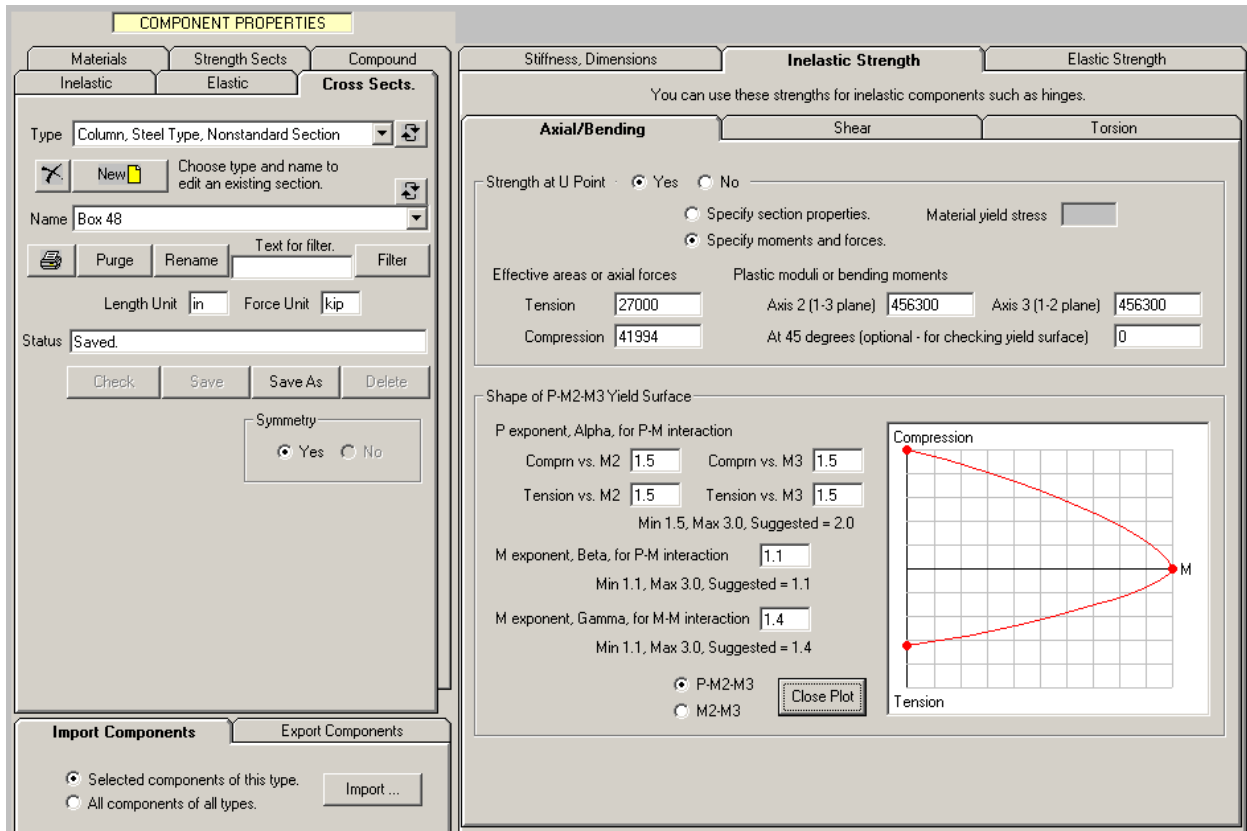

Figure 11: Column Strength Definition in Perform

3.2.1.3 Modeling of the Diaphragms at Upper, Ground and Basement Levels

We modeled the diaphragms at all elevated floors as rigid diaphragms. However, the diaphragms at the ground and all basement floors were modeled with elastic shell elements with 30% of the gross cross section properties. We considered an effective thickness comprising of the total thickness of the topping plus half the rib thickness. Thus the ground floor was modeled as 10.5 in. thick slab as it represents a 9 in. topping and 1.5 in. half rib height. We followed the same approach for the basement slabs except that that the modulus of elasticity also included the λ modifier corresponding to lightweight concrete.

3.2.1.4 Modeling of Perimeter Walls

We modeled the perimeter shear walls as elastic wall elements with cracked stiffness equaling 50% of the gross stiffness. The elastic shear modulus was considered to be 40% of the gross elastic (Young's) modulus per ASCE 41, Supplement #1.

3.2.2 Selected Results from Non Linear Analysis

3.2.2.1 Story Drifts

We present the story drifts from the non linear analysis in Figures 12 and 13. Figure 12 shows the drift in the Y direction whereas Figure 13 shows the corresponding drift in the X direction. The maximum drift in the Y direction is around 2.13% while the maximum in the X direction is at 1.80%. As can be observed from the figures, the drifts are less than the permissible value of 3% in both directions and the mean peak drifts are generally on the order of 1.25% or less.

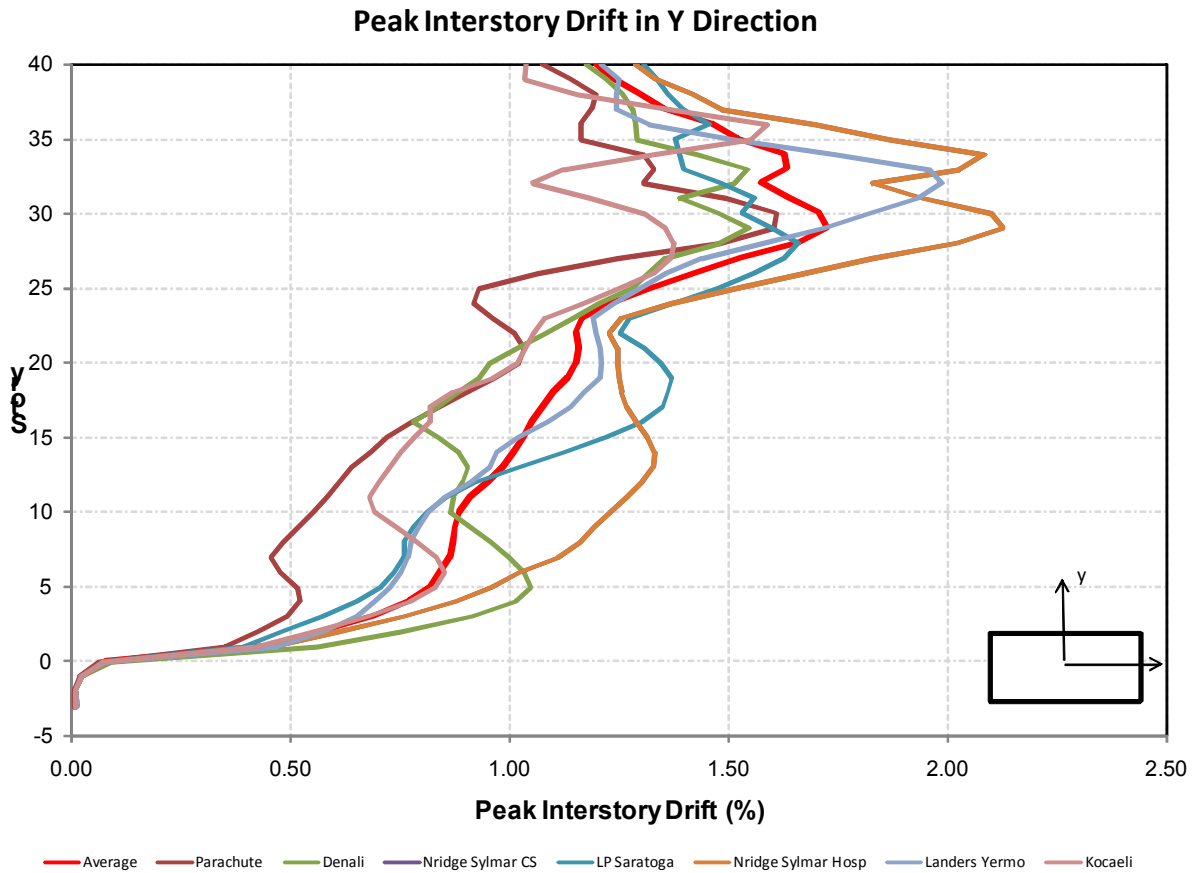

Figure 12: Peak Interstory Drifts in the Y Direction

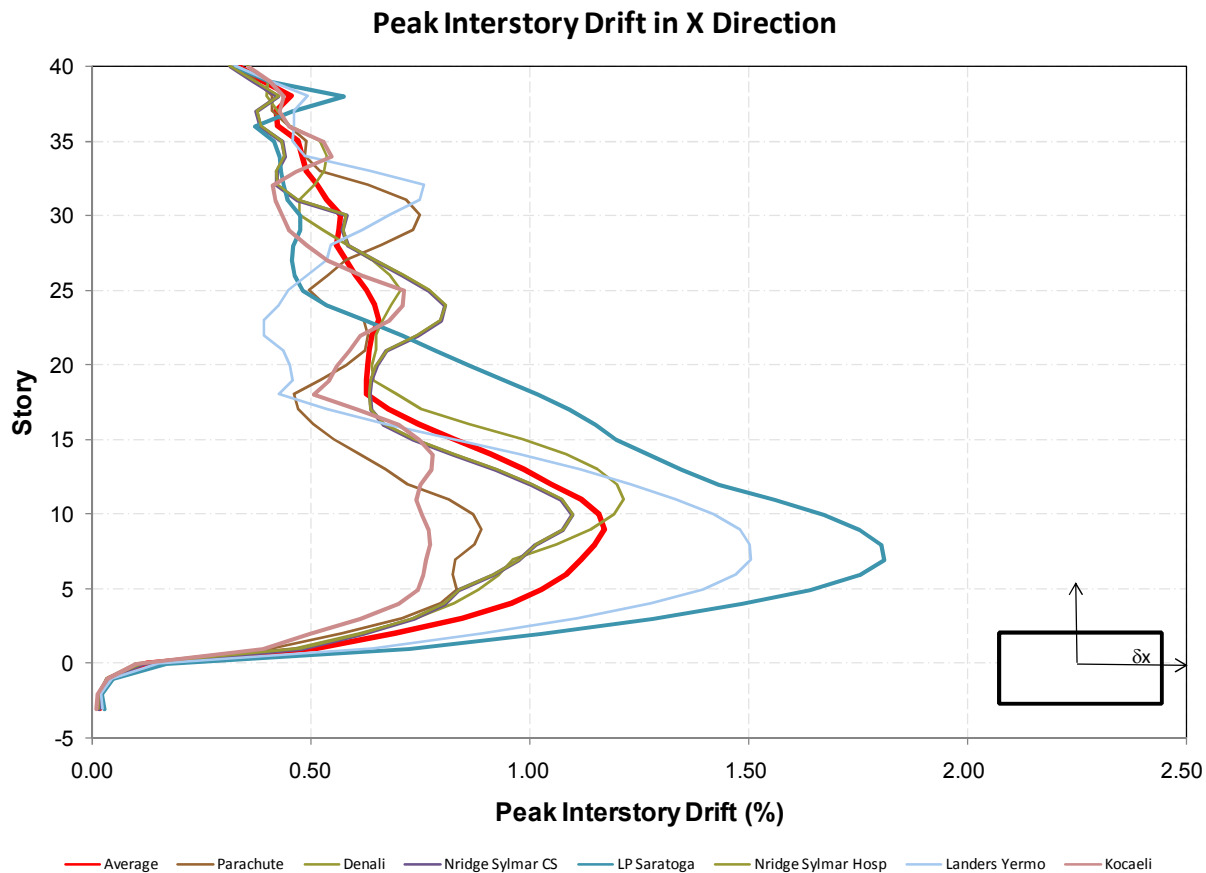

Figure 13: Peak Interstory Drifts in the X Direction

3.2.2.2 Buckling Restrained Brace Core Strain

We also monitored strain in the cores of the buckling restrained braces and ensured that the mean strain is less than of 0.013 ($10\epsilon_y$) obtained from the test results conducted at the University of Utah by Romero and Reavely. Figure 14 shows the buckling restrained brace core strain for lines 2, 3 and 4 respectively. The results are presented as D/C ratio with the capacity being 0.013. Similar information for line D is presented in Figure 15. The ratios are all less than unity implying acceptable performance.

0.0920 0.090
0.126 0.126
0.15 0.155
0.224 0.196
0.303 0.257
0.328 0.28
0.373 0.321
0.376 0.381
0.33 0.404
0.352 0.411
0.408 0.404
0.422 0.388
0.395 0.37
0.36 0.276
0.337 0.287
0.315 0.234
0.281 0.213
0.251 0.187
0.256 0.187
0.272 0.211
0.28 0.218
0.285 0.228
0.286 0.223
0.287 0.226
0.299 0.233
0.308 0.231
0.306 0.238
0.29 0.224
0.285 0.218
0.248 0.208
0.241 0.213
0.247 0.224
0.253 0.234
0.262 0.247
0.253 0.281
0.301 0.27
0.296 0.271
0.273 0.236
0.229 0.221
0.161 0.152
0.038 0.038
0.023 0.023
0.018 0.018
0.01 0.011

Line 2

0.069 0.088
0.103 0.183
0.13 0.151
0.206 0.181
0.291 0.24
0.322 0.287
0.38 0.313
0.405 0.377
0.365 0.428
0.406 0.442
0.464 0.438
0.484 0.408
0.456 0.388
0.408 0.296
0.382 0.275
0.362 0.256
0.33 0.233
0.292 0.216
0.297 0.223
0.316 0.244
0.327 0.256
0.332 0.26
0.332 0.261
0.336 0.268
0.348 0.278
0.356 0.283
0.354 0.28
0.339 0.285
0.316 0.258
0.293 0.253
0.286 0.255
0.292 0.264
0.307 0.271
0.321 0.283
0.328 0.293
0.331 0.296
0.323 0.291
0.295 0.274
0.247 0.236
0.151 0.148
0.052 0.058
0.023 0.023
0.018 0.017
0.013 0.013

Line 3

0.072 0.072
0.107 0.183
0.135 0.136
0.212 0.186
0.293 0.242
0.326 0.27
0.382 0.31
0.411 0.38
0.37 0.432
0.417 0.446
0.478 0.447
0.447 0.411
0.462 0.388
0.415 0.311
0.387 0.282
0.366 0.268
0.332 0.245
0.29 0.224
0.294 0.21
0.311 0.247
0.334 0.234
0.326 0.237
0.325 0.233
0.332 0.288
0.345 0.277
0.354 0.281
0.352 0.272
0.337 0.285
0.311 0.234
0.292 0.247
0.283 0.243
0.287 0.233
0.301 0.287
0.315 0.273
0.321 0.288
0.322 0.283
0.315 0.285
0.29 0.27
0.244 0.232
0.147 0.145
0.053 0.054
0.024 0.023
0.015 0.015
0.013 0.013

Line 4

Figure 14: BRBF Core Strain DCRs along Lines 2, 3 and 4

0.063	0.064	0.073	0.074	0.06	0.06
0.096	0.096	0.107	0.107	0.093	0.094
0.132	0.13	0.14	0.138	0.128	0.128
0.114	0.113	0.122	0.122	0.111	0.113
0.114	0.114	0.129	0.127	0.109	0.112
0.126	0.122	0.152	0.153	0.124	0.127
0.131	0.128	0.161	0.162	0.128	0.133
0.132	0.128	0.168	0.164	0.128	0.132
0.143	0.14	0.181	0.178	0.142	0.142
0.166	0.164	0.201	0.203	0.162	0.167
0.203	0.2	0.236	0.247	0.196	0.204
0.206	0.206	0.239	0.252	0.199	0.21
0.195	0.192	0.228	0.237	0.187	0.197
0.181	0.178	0.227	0.226	0.173	0.182
0.192	0.178	0.244	0.225	0.187	0.181
0.203	0.18	0.261	0.225	0.2	0.185
0.214	0.191	0.272	0.226	0.209	0.2
0.218	0.198	0.275	0.231	0.217	0.207
0.209	0.194	0.284	0.229	0.209	0.198
0.199	0.198	0.258	0.235	0.197	0.197
0.196	0.206	0.257	0.248	0.196	0.204
0.204	0.214	0.256	0.256	0.198	0.211
0.214	0.221	0.271	0.265	0.216	0.218
0.247	0.231	0.3	0.276	0.249	0.228
0.29	0.248	0.339	0.293	0.291	0.257
0.334	0.284	0.385	0.327	0.337	0.295
0.388	0.329	0.436	0.365	0.39	0.334
0.435	0.36	0.481	0.402	0.437	0.37
0.473	0.388	0.516	0.43	0.475	0.398
0.504	0.42	0.545	0.463	0.507	0.424
0.523	0.483	0.562	0.493	0.526	0.456
0.526	0.498	0.562	0.525	0.53	0.491
0.514	0.52	0.548	0.544	0.517	0.518
0.493	0.528	0.525	0.55	0.498	0.521
0.471	0.523	0.5	0.543	0.475	0.516
0.448	0.512	0.47	0.528	0.449	0.506
0.42	0.48	0.44	0.496	0.42	0.476
0.374	0.424	0.391	0.439	0.373	0.421
0.309	0.341	0.324	0.356	0.307	0.34
0.2	0.207	0.205	0.217	0.195	0.209
0.07	0.067	0.073	0.071	0.067	0.067
0.025	0.024	0.028	0.028	0.024	0.025
0.011	0.013	0.011	0.013	0.011	0.013
0.01	0.012	0.01	0.011	0.011	0.012

Figure 15: BRBF Core Strain DCR Along Line D

3.2.2.3 Column Axial Flexure Interaction Ratio

Figure 16 shows the axial load and flexure interaction ratio for the seismic frame columns along line E. As can be seen from the figure, the maximum mean interaction ratio is 0.54. The absolute maximum from the seven analysis is 0.73 signifying elastic behavior of the columns.

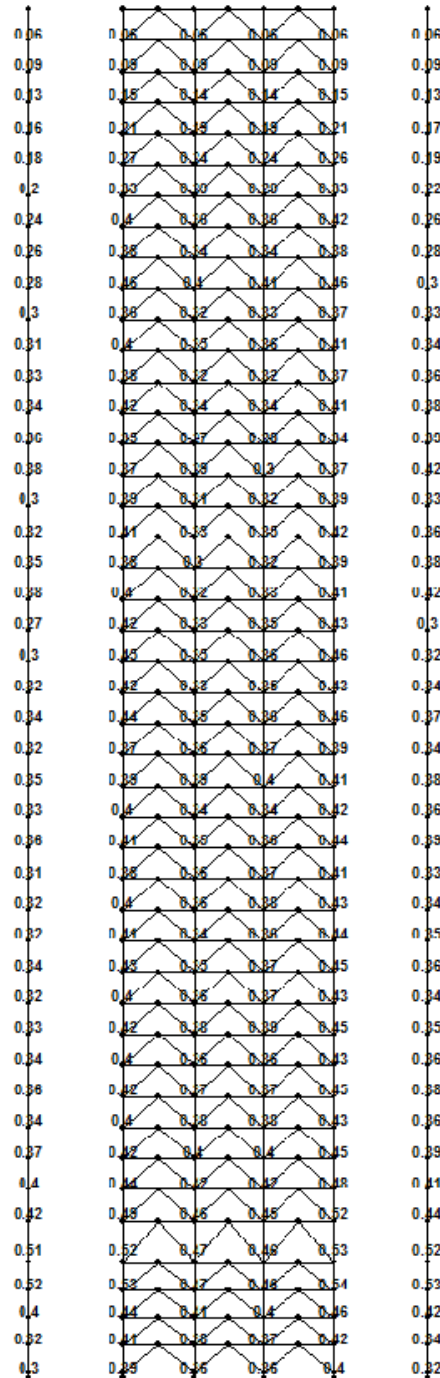

Figure 16: Seismic Frame Column Axial Flexure Interaction Ratio along Line E

3.2.2.4 Story Shears

We also monitored the story shears over the height of the building. Figure 17 and Figure 18 plot the story shears in the Y direction and X direction respectively. The effect of the stiff ground floor diaphragms is easily observable from the plots. We have proportioned the ground floor slab and the collectors so that it is capable of transferring this large reaction.

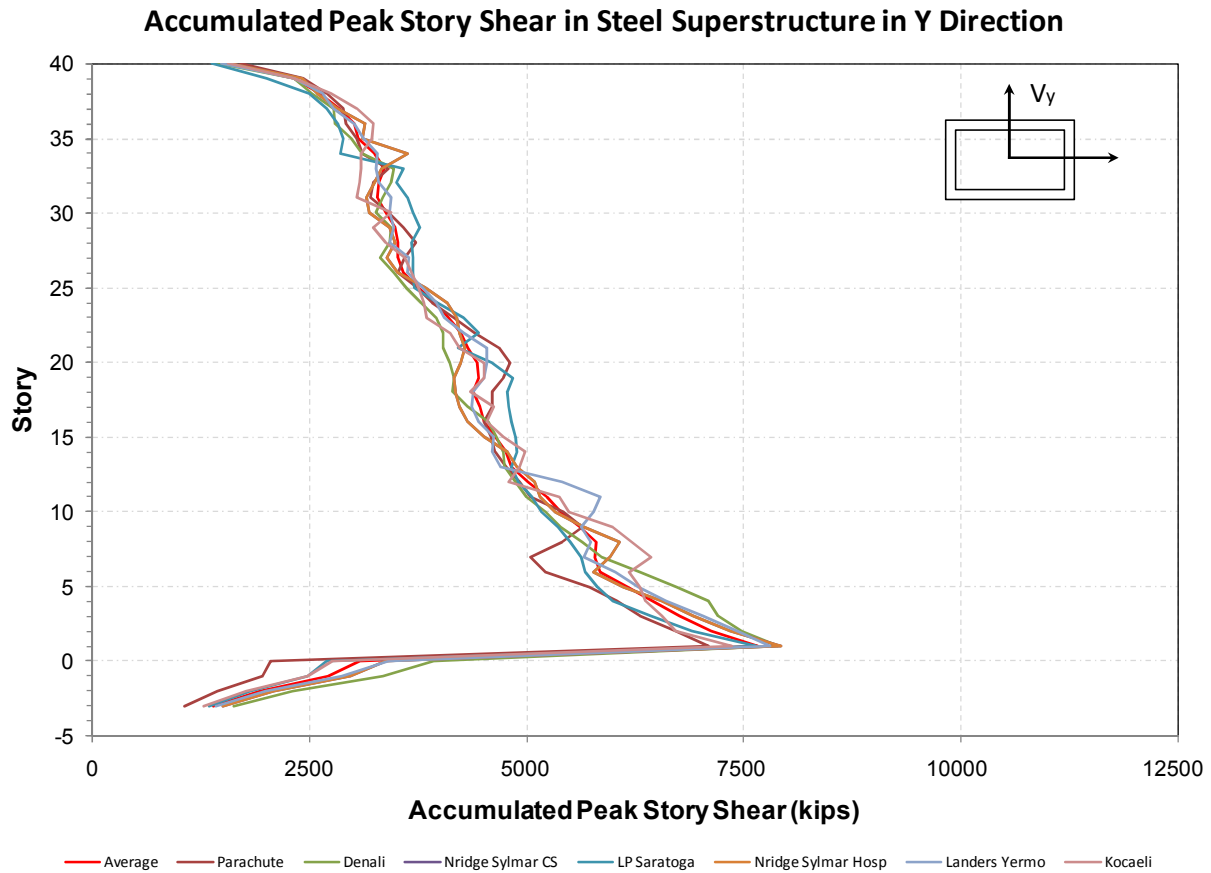

Figure 17: Accumulated Peak Story Shear in Steel Superstructure in Y Direction

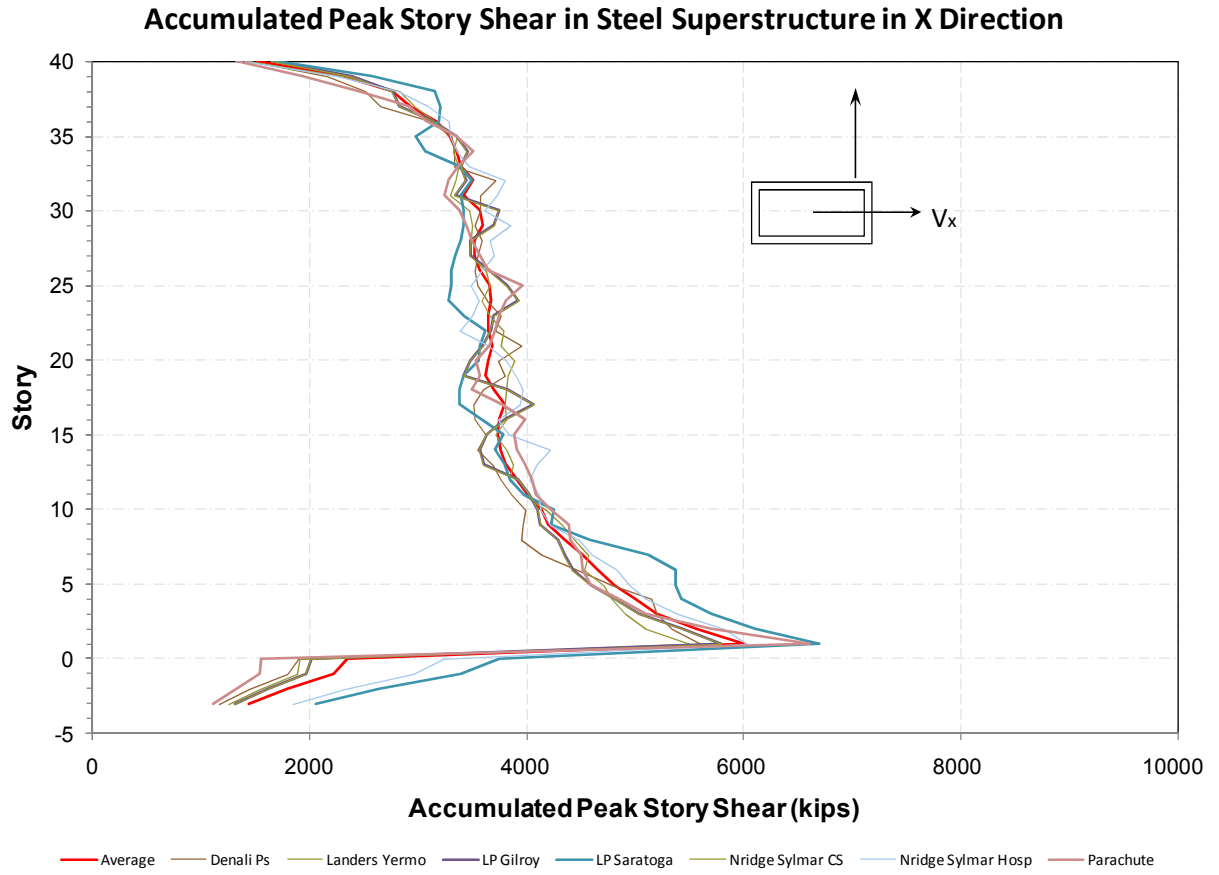

Figure 18: Accumulated Peak Story Shear in Steel Superstructure in X Direction

4. ENHANCED PERFORMANCE BASED DESIGN

We based the seismic design for this alternate on the seismic design criteria provided to us by PEER. The following table shows summary of the criteria for this design.

Table 7 – Seismic Performance Objectives

Level of Earthquake	Earthquake Performance Objectives
Frequent/Service : 43 year return period, 2.5% damping	Serviceability: Drift limited to 0.5%. Demand capacity ratio for buckling restrained braces not to exceed 1.5.
Maximum Considered Earthquake (MCE): As defined by ASCE 7-05, Section 21.2, 2.5% damping.	Collapse Prevention: Extensive structural damage, repairs are required and may not be economically feasible. Drift limited to 3%

4.1 Service Level Earthquake Evaluation

We used a response spectrum provided to us by PEER for this evaluation. We observed that using the BRB sizes from the Performance Based Alternate caused overstress in some of the braces. This was particularly severe along the longitudinal direction of the building. As a result we had to upsize some of the braces. Additionally, we had to use an outrigger that projected out from the core on lines 2 and 7. This outrigger was provided at the roof, the 30th floor and the 20th floor. Figure 19 shows the response spectrum used for the evaluation and Figure 20 shows the 3D view of the computer model along with the outriggers.

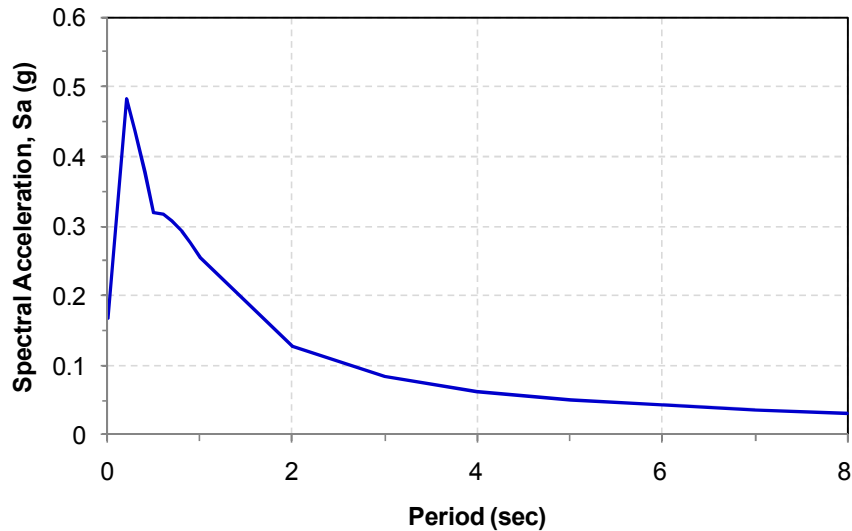

Figure 19: Response Spectrum for Enhanced PBE

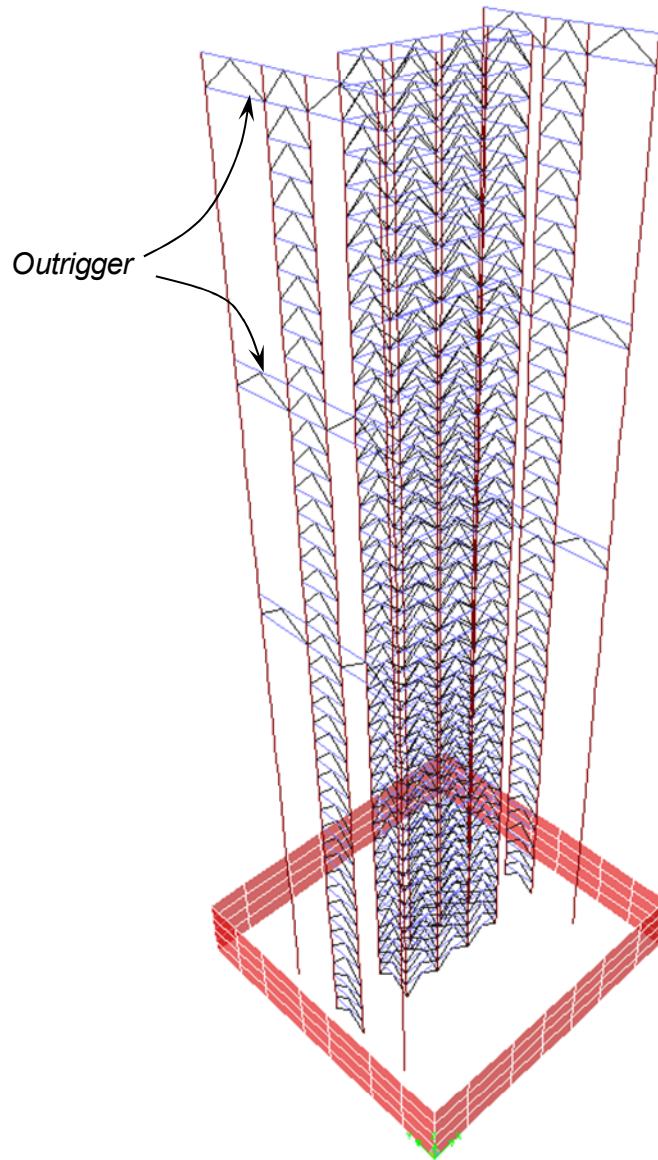

Figure 20: 3D Computer Model used for the Enhanced Performance Based Evaluation

Table 8 shows the drifts from the service level evaluation along the transverse and longitudinal directions of the building. As can be observed, the drifts are all less than the 0.5% limit.

Table 8 – Story Drifts for Service Level Earthquake

Story	Y Direction Drifts	X Direction Drifts
Story 40	0.0031	0.0022
Story 39	0.0042	0.0024
Story 38	0.0047	0.0026
Story 37	0.0048	0.0027
Story 36	0.0049	0.0028
Story 35	0.0049	0.0029
Story 34	0.0049	0.0029
Story 33	0.0049	0.0029
Story 32	0.0049	0.0029
Story 31	0.0046	0.0030
Story 30	0.0034	0.0029
Story 29	0.0045	0.0029
Story 28	0.0047	0.0029
Story 27	0.0046	0.0029
Story 26	0.0046	0.0029
Story 25	0.0045	0.0028
Story 24	0.0044	0.0028
Story 23	0.0043	0.0028
Story 22	0.0041	0.0027
Story 21	0.0037	0.0027
Story 20	0.0029	0.0027
Story 19	0.0035	0.0027
Story 18	0.0037	0.0026

Story	Y Direction Drifts	X Direction Drifts
Story 17	0.0037	0.0026
Story 16	0.0036	0.0026
Story 15	0.0036	0.0026
Story 14	0.0035	0.0025
Story 13	0.0034	0.0025
Story 12	0.0033	0.0025
Story 11	0.0032	0.0025
Story 10	0.0031	0.0025
Story 9	0.0030	0.0025
Story 8	0.0030	0.0025
Story 7	0.0029	0.0025
Story 6	0.0028	0.0025
Story 5	0.0027	0.0025
Story 4	0.0025	0.0024
Story 3	0.0024	0.0023
Story 2	0.0021	0.0021
Story 1	0.0014	0.0014

4.1 Maximum Considered Earthquake Evaluation

We used the same time histories and modeling assumptions as presented earlier in the Performance Based Evaluation section. Figure 21 shows the drift in the Y direction whereas Figure 22 shows the corresponding drift in the X direction. The maximum drift in the Y direction is around 1.33% while the maximum in the X direction is at 1.42%. As can be observed from the figures, the drifts are less than the permissible value of 3% in both directions and the mean peak drifts are generally on the order of 1.0% or less.

Peak Interstory Drift in Y Direction

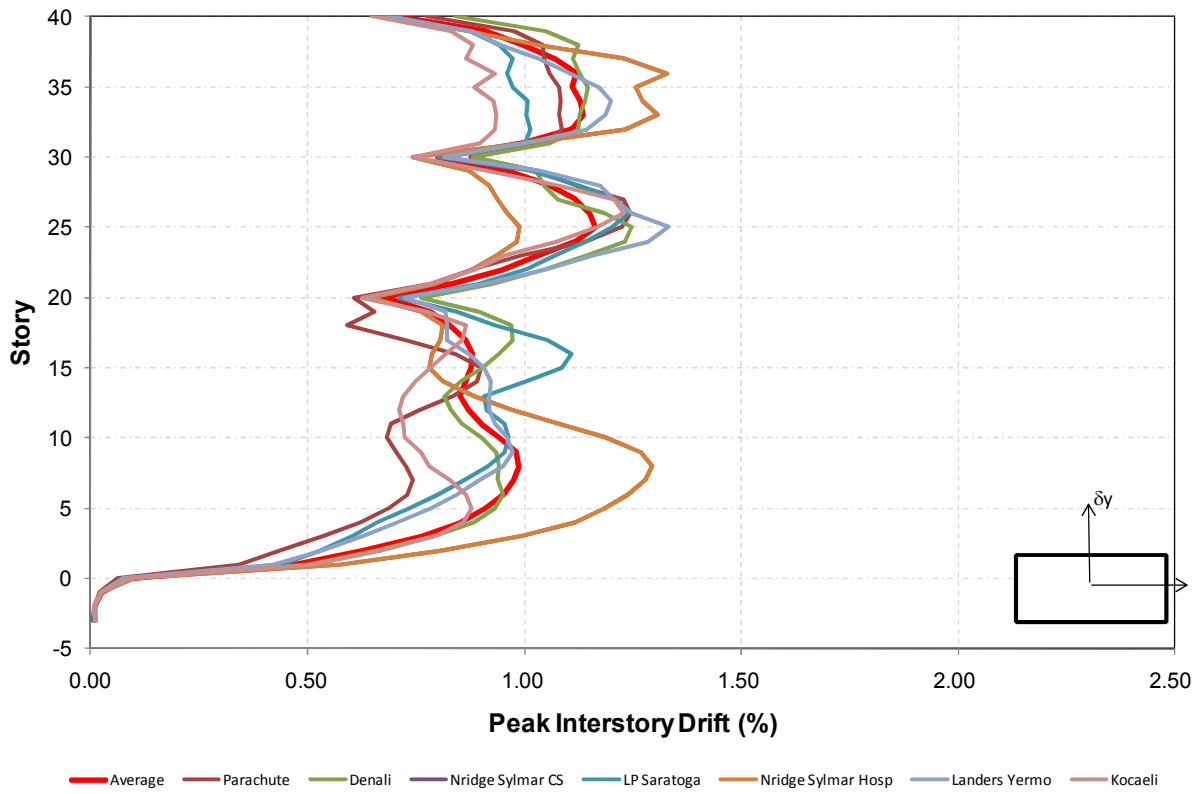

Figure 21: Peak Interstory Drifts in the Y Direction

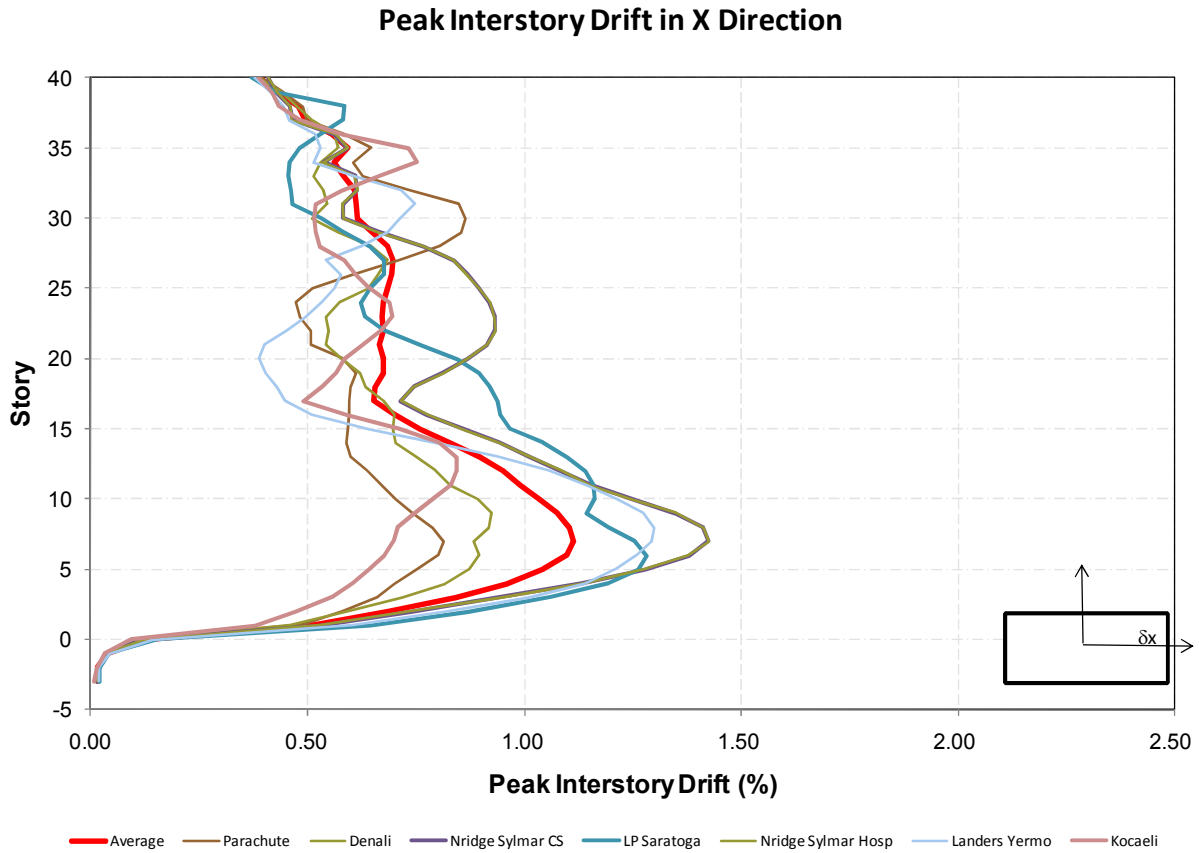

Figure 22: Peak Interstory Drifts in the X Direction

We also examined the strains in the buckling restrained braces and the axial moment interaction in the columns. In general they followed the same trend as the earlier Performance Based Evaluation with the maximum strain demand capacity ratio of 0.58. The maximum demand capacity ratio for the column was around 0.75.

APPENDIX A



CLIENT CSSC
 SUBJECT LA BRBF Building, LA, CA

SHEET NO. _____
 PROJECT NO. 087237_00
 DATE 11/26/08
 BY AD
 CHECKED BY ROH

ROOF FLAT LOADS **ROOF**

Level	Material	Slab (psf)	Beam (psf)	Cols (psf)	Seismic (psf)	Gr. Cols (psf)	Remarks
Roof	Roofing	5.0	5.0	5.0	5.0	5.0	
"	3-1/4" Lwt. conc. over 3" mtl deck	48.5	48.5	48.5	48.5	48.5	
"	20 Ga. Metal deck	3.0	3.0	3.0	3.0	3.0	
"	Struct. Steel framing			5.0	5.0	5.0	Beam weight calculated by RAM
"	Drop ceiling	2.0	2.0	2.0	2.0	2.0	
"	MEP	2.0	2.0	2.0	2.0	2.0	Ceiling mounted
"	Gravity columns				1.5	1.5	
"	Seismic Frame			8.0	8.0		
"	Partitions				5.0		
"	Miscellaneous	19.0	19.0	19.0	14.0	19.0	
	<i>Sum of Dead Loads</i>	79.5	79.5	92.5	94.0	86.0	
	<i>Sum of Live Loads</i>	25.0	25.0	25.0	-	25.0	
	<i>Sum of Dead Plus Live Loads</i>	104.5	104.5	117.5	94.0	111.0	

FLOOR FLAT LOADS **TYPICAL FLOORS 39th THROUGH 33rd**

Level	Material	Slab (psf)	Beam (psf)	Cols (psf)	Seismic (psf)	Gr. Cols (psf)	Remarks
Floor	Partitions	20.0	20.0	20.0	10.0	20.0	
"	Carpet floor finish	2.0	2.0	2.0	2.0	2.0	
"	20 Ga. Metal deck	3.0	3.0	3.0	3.0	3.0	
"	3-1/4" Lwt. conc. over 3" mtl deck	48.5	48.5	48.5	48.5	48.5	
"	Struct. Steel framing			5.0	5.0		Beam weight calculated by RAM
"	Drop ceiling	2.0	2.0	2.0	2.0	2.0	
"	MEP	3.0	3.0	3.0	3.0	3.0	Ceiling mounted
"	Gravity columns				2.0	2.0	
"	Seismic Frames			11.5	11.5		
"	Miscellaneous	1.0	1.0	1.0	1.0	1.0	***
	<i>Sum of Dead Loads</i>	79.5	79.5	96.0	88.0	81.5	
	<i>Sum of Live Loads</i>	40.0	40.0	40.0	-	40.0	
	<i>Sum of Dead Plus Live Loads</i>	119.5	119.5	136.0	88.0	121.5	

FLOOR FLAT LOADS **TYPICAL FLOORS 32nd THROUGH 28th**

Level	Material	Slab (psf)	Beam (psf)	Cols (psf)	Seismic (psf)	Gr. Cols (psf)	Remarks
Floor	Partitions	20.0	20.0	20.0	10.0	20.0	
"	Carpet floor finish	2.0	2.0	2.0	2.0	2.0	
"	20 Ga. Metal deck	3.0	3.0	3.0	3.0	3.0	
"	3-1/4" Lwt. conc. over 3" mtl deck	48.5	48.5	48.5	48.5	48.5	
"	Struct. Steel framing			5.0	5.0		Beam weight calculated by RAM
"	Drop ceiling	2.0	2.0	2.0	2.0	2.0	
"	MEP	3.0	3.0	3.0	3.0	3.0	Ceiling mounted
"	Gravity columns				2.5	2.5	
"	Seismic Frames			15.0	15.0		
"	Miscellaneous	1.0	1.0	1.0	1.0	1.0	***
	<i>Sum of Dead Loads</i>	79.5	79.5	99.5	92.0	82.0	
	<i>Sum of Live Loads</i>	40.0	40.0	40.0	-	40.0	
	<i>Sum of Dead Plus Live Loads</i>	119.5	119.5	139.5	92.0	122.0	



SHEET NO. _____

PROJECT NO. 087237.00

DATE 11/26/08

CLIENT CSSC

BY AD

SUBJECT LA BRBF Building, LA, CA

CHECKED BY ROH

FLOOR FLAT LOADS **TYPICAL FLOORS 27th THROUGH 24th**

Level	Material	Slab (psf)	Beam (psf)	Cols (psf)	Seismic (psf)	Gr. Cols (psf)	Remarks
Floor	Partitions	20.0	20.0	20.0	10.0	20.0	
"	Carpet floor finish	2.0	2.0	2.0	2.0	2.0	
"	20 Ga. Metal deck	3.0	3.0	3.0	3.0	3.0	
"	3-1/4" Lwt. conc. over 3" mtl deck	48.5	48.5	48.5	48.5	48.5	
"	Struct. Steel framing			5.0	5.0		Beam weight calculated by RAM
"	Drop ceiling	2.0	2.0	2.0	2.0	2.0	
"	MEP	3.0	3.0	3.0	3.0	3.0	Ceiling mounted
"	Gravity columns				2.5	2.5	
"	Seismic Frames			19.0	19.0		
"	Miscellaneous	1.0	1.0	1.0	1.0	1.0	...
<i>Sum of Dead Loads</i>		79.5	79.5	103.5	96.0	82.0	
<i>Sum of Live Loads</i>		40.0	40.0	40.0	-	40.0	
<i>Sum of Dead Plus Live Loads</i>		119.5	119.5	143.5	96.0	122.0	

FLOOR FLAT LOADS **TYPICAL FLOORS 23rd THROUGH 20th**

Level	Material	Slab (psf)	Beam (psf)	Cols (psf)	Seismic (psf)	Gr. Cols (psf)	Remarks
Floor	Partitions	20.0	20.0	20.0	10.0	20.0	
"	Carpet floor finish	2.0	2.0	2.0	2.0	2.0	
"	20 Ga. Metal deck	3.0	3.0	3.0	3.0	3.0	
"	3-1/4" Lwt. conc. over 3" mtl deck	48.5	48.5	48.5	48.5	48.5	
"	Struct. Steel framing			5.0	5.0		Beam weight calculated by RAM
"	Drop ceiling	2.0	2.0	2.0	2.0	2.0	
"	MEP	3.0	3.0	3.0	3.0	3.0	Ceiling mounted
"	Gravity columns				3.0		
"	Seismic Frames			24.5	24.5		
"	Miscellaneous	1.0	1.0	1.0	1.0	1.0	...
<i>Sum of Dead Loads</i>		79.5	79.5	109.0	102.0	79.5	
<i>Sum of Live Loads</i>		40.0	40.0	40.0	-	40.0	
<i>Sum of Dead Plus Live Loads</i>		119.5	119.5	149.0	102.0	119.5	

FLOOR FLAT LOADS **TYPICAL FLOORS 19th THROUGH 15th**

Level	Material	Slab (psf)	Beam (psf)	Cols (psf)	Seismic (psf)	Gr. Cols (psf)	Remarks
Floor	Partitions	20.0	20.0	20.0	10.0	20.0	
"	Carpet floor finish	2.0	2.0	2.0	2.0	2.0	
"	20 Ga. Metal deck	3.0	3.0	3.0	3.0	3.0	
"	3-1/4" Lwt. conc. over 3" mtl deck	48.5	48.5	48.5	48.5	48.5	
"	Struct. Steel framing			5.0	5.0		Beam weight calculated by RAM
"	Drop ceiling	2.0	2.0	2.0	2.0	2.0	
"	MEP	3.0	3.0	3.0	3.0	3.0	Ceiling mounted
"	Gravity columns				2.5	2.5	
"	Seismic Frames			30.0	30.0		
"	Miscellaneous	1.0	1.0	1.0	1.0	1.0	...
<i>Sum of Dead Loads</i>		79.5	79.5	114.5	107.0	82.0	
<i>Sum of Live Loads</i>		40.0	40.0	40.0	-	40.0	
<i>Sum of Dead Plus Live Loads</i>		119.5	119.5	154.5	107.0	122.0	



SHEET NO. _____
 PROJECT NO. 087237.00
 DATE 11/26/08
 BY AD

CLIENT CSSC

SUBJECT LA BRBF Building, LA, CA

CHECKED BY ROH

FLOOR FLAT LOADS

TYPICAL FLOORS 14th THROUGH 10th

Level	Material	Slab (psf)	Beam (psf)	Cols (psf)	Seismic (psf)	Gr. Cols (psf)	Remarks
Floor	Partitions	20.0	20.0	20.0	10.0	20.0	
"	Carpet floor finish	2.0	2.0	2.0	2.0	2.0	
"	20 Ga. Metal deck	3.0	3.0	3.0	3.0	3.0	
"	3-1/4" Lwt. conc. over 3" mtl deck	48.5	48.5	48.5	48.5	48.5	
"	Struct. Steel framing			5.0	5.0		Beam weight calculated by RAM
"	Drop ceiling	2.0	2.0	2.0	2.0	2.0	
"	MEP	3.0	3.0	3.0	3.0	3.0	Ceiling mounted
"	Gravity columns				2.5	2.5	
"	Seismic Frames			38.0	38.0		
"	Miscellaneous	1.0	1.0	1.0	1.0	1.0	...
<i>Sum of Dead Loads</i>		79.5	79.5	122.5	115.0	82.0	
<i>Sum of Live Loads</i>		40.0	40.0	40.0	-	40.0	
<i>Sum of Dead Plus Live Loads</i>		119.5	119.5	162.5	115.0	122.0	

FLOOR FLAT LOADS

TYPICAL FLOORS 9th THROUGH 5th

Level	Material	Slab (psf)	Beam (psf)	Cols (psf)	Seismic (psf)	Gr. Cols (psf)	Remarks
Floor	Partitions	20.0	20.0	20.0	10.0	20.0	
"	Carpet floor finish	2.0	2.0	2.0	2.0	2.0	
"	20 Ga. Metal deck	3.0	3.0	3.0	3.0	3.0	
"	3-1/4" Lwt. conc. over 3" mtl deck	48.5	48.5	48.5	48.5	48.5	
"	Struct. Steel framing			5.0	5.0		Beam weight calculated by RAM
"	Drop ceiling	2.0	2.0	2.0	2.0	2.0	
"	MEP	3.0	3.0	3.0	3.0	3.0	Ceiling mounted
"	Gravity columns				2.5	2.5	
"	Seismic Frames			43.0	43.0		
"	Miscellaneous	1.0	1.0	1.0	1.0	1.0	...
<i>Sum of Dead Loads</i>		79.5	79.5	127.5	120.0	82.0	
<i>Sum of Live Loads</i>		55.0	55.0	55.0	-	55.0	Includes 15 psf partition loading
<i>Sum of Dead Plus Live Loads</i>		134.5	134.5	182.5	120.0	137.0	

FLOOR FLAT LOADS

TYPICAL FLOORS 4th THROUGH 2nd

Level	Material	Slab (psf)	Beam (psf)	Cols (psf)	Seismic (psf)	Gr. Cols (psf)	Remarks
Floor	Partitions	20.0	20.0	20.0	10.0	20.0	
"	Carpet floor finish	2.0	2.0	2.0	2.0	2.0	
"	20 Ga. Metal deck	3.0	3.0	3.0	3.0	3.0	
"	3-1/4" Lwt. conc. over 3" mtl deck	48.5	48.5	48.5	48.5	48.5	
"	Struct. Steel framing			5.0	5.0		Beam weight calculated by RAM
"	Drop ceiling	2.0	2.0	2.0	2.0	2.0	
"	MEP	3.0	3.0	3.0	3.0	3.0	Ceiling mounted
"	Gravity columns				2.5	2.5	
"	Seismic Frames			50.0	50.0		
"	Miscellaneous	1.0	1.0	1.0	1.0	1.0	...
<i>Sum of Dead Loads</i>		79.5	79.5	134.5	127.0	82.0	
<i>Sum of Live Loads</i>		40.0	40.0	40.0	-	40.0	
<i>Sum of Dead Plus Live Loads</i>		119.5	119.5	174.5	127.0	122.0	



SHEET NO. _____
 PROJECT NO. 087237.00
 DATE 11/26/08
 BY AD
 CHECKED BY ROH

CLIENT CSSC

SUBJECT LA BRBF Building, LA, CA

FLOOR FLAT LOADS **1ST FLOOR**

Level	Material	Slab (psf)	Beam (psf)	Cols (psf)	Seismic (psf)	Gr. Cols (psf)	Remarks
Floor	Partitions	20.0	20.0	20.0	10.0	20.0	
"	Carpet floor finish	2.0	2.0	2.0	2.0	2.0	
"	20 Ga. Metal deck	3.0	3.0	3.0	3.0	3.0	
"	3-1/4" Lwt. conc. over 3" mtl deck	48.5	48.5	48.5	48.5	48.5	
"	Struct. Steel framing			5.0	5.0		Beam weight calculated by RAM
"	Drop ceiling	2.0	2.0	2.0	2.0	2.0	
"	MEP	3.0	3.0	3.0	3.0	3.0	Ceiling mounted
"	Gravity columns				2.5	2.5	
"	Seismic Frames			60.0	60.0		
"	Miscellaneous	1.0	1.0	1.0	1.0	1.0	...
<i>Sum of Dead Loads</i>		79.5	79.5	144.5	137.0	82.0	
<i>Sum of Live Loads</i>		40.0	40.0	40.0	-	40.0	
<i>Sum of Dead Plus Live Loads</i>		119.5	119.5	184.5	137.0	122.0	

FLOOR FLAT LOADS **GROUND FLOOR INSIDE CORE**

Level	Material	Slab (psf)	Beam (psf)	Cols (psf)	Seismic (psf)	Gr. Cols (psf)	Remarks
Floor	Partitions	20.0	20.0	20.0	10.0	20.0	
"	Carpet floor finish	2.0	2.0	2.0	2.0	2.0	
"	18 Ga. Metal deck	3.0	3.0	3.0	3.0	3.0	
"	9" Nwt. conc. over 3" mtl deck	127.0	127.0	127.0	127.0	127.0	
"	Struct. Steel framing			8.0	8.0		Beam weight calculated by RAM
"	Drop ceiling	2.0	2.0	2.0	2.0	2.0	
"	MEP	3.0	3.0	3.0	3.0	3.0	Ceiling mounted
"	Gravity columns				3.0	3.0	
"	Seismic Frames			27.5	27.5		
"	Miscellaneous	83.0	83.0	83.0	83.0	83.0	
<i>Sum of Dead Loads</i>		220.0	220.0	255.5	258.5	223.0	
<i>Sum of Live Loads</i>		100.0	100.0	100.0	-	100.0	
<i>Sum of Dead Plus Live Loads</i>		320.0	320.0	355.5	258.5	323.0	

FLOOR FLAT LOADS **GROUND FLOOR PLAZA**

Level	Material	Slab (psf)	Beam (psf)	Cols (psf)	Seismic (psf)	Gr. Cols (psf)	Remarks
Floor	Plant beds etc.	347.0	347.0	347.0	347.0	347.0	
"	18 Ga. Metal deck	3.0	3.0	3.0	3.0	3.0	
"	9" Nwt. conc. over 3" mtl deck	127.0	127.0	127.0	127.0	127.0	
"	Struct. Steel framing			8.0	8.0		Beam weight calculated by RAM
"	MEP	3.0	3.0	3.0	3.0	3.0	Ceiling mounted
"	Gravity columns				3.0	3.0	
"	Seismic Frames			27.5	27.5		
"	Miscellaneous	0.0	0.0	0.0	0.0	0.0	
<i>Sum of Dead Loads</i>		480.0	480.0	515.5	518.5	483.0	
<i>Sum of Live Loads</i>		100.0	100.0	100.0	-	100.0	
<i>Sum of Dead Plus Live Loads</i>		580.0	580.0	615.5	518.5	583.0	

FLOOR FLAT LOADS **BASEMENT**

Level	Material	Slab (psf)	Beam (psf)	Cols (psf)	Seismic (psf)	Gr. Cols (psf)	Remarks
Floor	18 Ga. Metal deck	3.0	3.0	3.0	3.0	3.0	
"	3-1/4" Lwt. conc. over 3" mtl deck	48.5	48.5	48.5	48.5	48.5	
"	Struct. Steel framing			6.0	6.0		Beam weight calculated by RAM
"	MEP	3.0	3.0	3.0	3.0	3.0	Ceiling mounted
"	Gravity columns				2.5	2.5	
"	Seismic Frames			23.0	23.0		
"	Miscellaneous						
<i>Sum of Dead Loads</i>		54.5	54.5	83.5	86.0	57.0	
<i>Sum of Live Loads</i>		40.0	40.0	40.0	-	40.0	
<i>Sum of Dead Plus Live Loads</i>		94.5	94.5	123.5	86.0	97.0	

SIMPSON GUMPERTZ & HEGER



Engineering of Structures
and Building Enclosures

CLIENT Pacific Earthquake Engineering Research Center

SUBJECT Gust Effect Factor in Short Normal Dir. for LA BRBF Bldg

SHEET NO. _____

PROJECT NO. 087237.10

DATE 1/23/09

BY AD

CHECKED BY _____

Exposure =	B	Vz-bar =	99.51 ft/s (Eq. 6-14)
Basic Wind Speed (V) =	85.00 mph	Lz-bar =	687.11
h (Mean Roof Height) =	544.50 ft	N1 =	1.73
z-bar =	326.70 ft	η_h =	6.29
α -bar =	0.25 (Table 6-2)	η_B =	1.24
b-bar =	0.45 (Table 6-2)	η_L =	6.58
l =	320.00 ft (Table 6-2)	Rh =	0.15
ε -bar =	0.33 (Table 6-2)	RB =	0.51
n1 =	0.25 Hz	RL =	0.14
B =	107.00 ft	Rn =	0.10
L =	170.00 ft	R =	0.65
β =	0.01 Damping	gR =	3.84
gQ =	3.40 (CI 6.5.8.2)	lz-bar =	0.20
gv =	3.40 (CI 6.5.8.2)	Q =	0.79
c =	0.30 (Table 6-2)	Gf =	0.97



SHEET NO. _____
 PROJECT NO. 087237.10
 DATE 1/23/09
 BY AD
 CHECKED BY _____

CLIENT Pacific Earthquake Engineering Research Center
 SUBJECT Wind Pressures In Short Normal Direction for LA BRBF Bldg

Exposure :	B	Topographic Factor		Parapet Pressure	
Basic Wind Speed (V):	85 mph (Fig 6-1)	K1 =	0 (Fig 6-4)	Kz-parapet=	1.61 (Case 1 Table 6-3)
Importance Factor (I) :	1 (Table 1-1, 6-1)	K2 =	0 (Fig 6-4)	qz=qp =	25.3
zg =	1200 ft (Table 6-2)	K3 =	0 (Fig 6-4)	Pp =	37.9 psf
α =	7 (Table 6-2)	Kzt =	1		
Kd =	0.85 (Table 6-4)	Gf =	0.97		
h (Mean roof Height) =	544.5 ft	qh =	25.2 psf		
Cp(windward) =	0.8 (Fig 6-6)				
GCpi =	0.18 (Fig 6-5 for Encl. Bldg.)				
	-0.18 (Fig 6-5 for Encl. Bldg.)				
Parapet Tip Height =	551 ft				
GCpn =	1.5 (6.5.12.2.4)				

Elevation (z)	Main Wind Force Resisting System							
	B	L	Kz	qz	Windward Pr.	Internal Pressure		Leeward Pr.
						Positive	Negative	
0	107	170	0.5747	9.04	6.98	4.54	-4.54	-9.30
15	107	170	0.57	9.04	6.98	4.54	-4.54	-9.30
20	107	170	0.62	9.81	7.58	4.54	-4.54	-9.30
25	107	170	0.67	10.46	8.08	4.54	-4.54	-9.30
30	107	170	0.70	11.01	8.51	4.54	-4.54	-9.30
40	107	170	0.76	11.96	9.24	4.54	-4.54	-9.30
50	107	170	0.81	12.75	9.84	4.54	-4.54	-9.30
60	107	170	0.85	13.43	10.37	4.54	-4.54	-9.30
70	107	170	0.89	14.03	10.84	4.54	-4.54	-9.30
80	107	170	0.93	14.58	11.26	4.54	-4.54	-9.30
90	107	170	0.96	15.08	11.64	4.54	-4.54	-9.30
100	107	170	0.99	15.54	12.00	4.54	-4.54	-9.30
120	107	170	1.04	16.37	12.64	4.54	-4.54	-9.30
140	107	170	1.09	17.10	13.21	4.54	-4.54	-9.30
160	107	170	1.13	17.77	13.73	4.54	-4.54	-9.30
180	107	170	1.17	18.38	14.19	4.54	-4.54	-9.30
200	107	170	1.20	18.94	14.63	4.54	-4.54	-9.30
250	107	170	1.28	20.19	15.59	4.54	-4.54	-9.30
300	107	170	1.35	21.27	16.43	4.54	-4.54	-9.30
350	107	170	1.41	22.22	17.17	4.54	-4.54	-9.30
400	107	170	1.47	23.09	17.83	4.54	-4.54	-9.30
450	107	170	1.52	23.88	18.44	4.54	-4.54	-9.30
500	107	170	1.57	24.61	19.01	4.54	-4.54	-9.30
550	107	170	1.61	25.29	19.53	4.54	-4.54	-9.30



SHEET NO. _____

PROJECT NO. 087237.10

DATE 1/23/09

CLIENT Pacific Earthquake Engineering Research Center

BY AD

SUBJECT Story Wind Forces in Short Normal Dir. for LA BRBF Bldg

CHECKED BY _____

B_y = 107 ft
e_y = 16.05 ft

Floor	Height	Cum Ht.	Wind Pressure		Story Force (KIPS)	M _T (KIP-IN)
			Windward	Leeward		
Story40	13.5	544.5	19.47	-9.30	41.58	8008.31
Story39	13.5	531	19.33	-9.30	41.37	7967.87
Story38	13.5	517.5	19.19	-9.30	41.17	7929.35
Story37	13.5	504	19.05	-9.30	40.96	7888.90
Story36	13.5	490.5	18.90	-9.30	40.75	7848.45
Story35	13.5	477	18.75	-9.30	40.53	7806.08
Story34	13.5	463.5	18.60	-9.30	40.31	7763.71
Story33	13.5	450	18.44	-9.30	40.09	7721.34
Story32	13.5	436.5	18.28	-9.30	39.85	7675.11
Story31	13.5	423	18.11	-9.30	39.61	7628.89
Story30	13.5	409.5	17.95	-9.30	39.37	7582.67
Story29	13.5	396	17.78	-9.30	39.13	7536.44
Story28	13.5	382.5	17.60	-9.30	38.87	7486.37
Story27	13.5	369	17.42	-9.30	38.61	7436.29
Story26	13.5	355.5	17.24	-9.30	38.35	7386.21
Story25	13.5	342	17.05	-9.30	38.07	7332.29
Story24	13.5	328.5	16.85	-9.30	37.78	7276.43
Story23	13.5	315	16.65	-9.30	37.49	7220.58
Story22	13.5	301.5	16.45	-9.30	37.20	7164.72
Story21	13.5	288	16.23	-9.30	36.88	7103.09
Story20	13.5	274.5	16.00	-9.30	36.56	7041.46
Story19	13.5	261	15.78	-9.30	36.23	6977.90
Story18	13.5	247.5	15.54	-9.30	35.90	6914.34
Story17	13.5	234	15.28	-9.30	35.52	6841.16
Story16	13.5	220.5	15.02	-9.30	35.15	6769.89
Story15	13.5	207	14.76	-9.30	34.77	6696.71
Story14	13.5	193.5	14.49	-9.30	34.37	6619.67
Story13	13.5	180	14.19	-9.30	33.95	6538.77
Story12	13.5	166.5	13.88	-9.30	33.49	6450.18
Story11	13.5	153	13.55	-9.30	33.01	6357.73
Story10	13.5	139.5	13.20	-9.30	32.51	6261.43
Story9	13.5	126	12.81	-9.30	31.95	6153.57
Story8	13.5	112.5	12.40	-9.30	31.36	6039.94
Story7	13.5	99	11.96	-9.30	30.73	5918.60
Story6	13.5	85.5	11.47	-9.30	30.02	5781.86
Story5	13.5	72	10.92	-9.30	29.22	5627.78
Story4	13.5	58.5	10.29	-9.30	28.31	5452.51
Story3	13.5	45	9.54	-9.30	27.23	5244.50
Story2	13.5	31.5	8.62	-9.30	25.89	4986.42
Story1	18	18	7.34	-9.30	32.06	6174.76
Ground	12	0	6.98	-9.30	0.00	0.00
B1	12					
B2	12					
B3	12					
				Σ=	1436.20	

SIMPSON GUMPERTZ & HEGER



Engineering of Structures
and Building Enclosures

CLIENT Pacific Earthquake Engineering Research Center

SUBJECT Gust Effect Factor in Long Normal Dir. for LA BRBF Bldg

SHEET NO. _____

PROJECT NO. 087237.10

DATE 1/23/09

BY AD

CHECKED BY _____

Exposure =	B	Vz-bar =	99.51 ft/s (Eq. 6-14)
Basic Wind Speed (V) =	85.00 mph	Lz-bar =	687.11
h (Mean Roof Height) =	544.50 ft	N1 =	1.38
z-bar =	326.70 ft	η_h =	5.03
α -bar =	0.25 (Table 6-2)	η_B =	1.57
b-bar =	0.45 (Table 6-2)	η_L =	3.31
l =	320.00 ft (Table 6-2)	Rh =	0.18
ε -bar =	0.33 (Table 6-2)	RB =	0.44
n1 =	0.20 Hz	RL =	0.26
B =	170.00 ft	Rn =	0.11
L =	107.00 ft	R =	0.75
β =	0.01 Damping	gR =	3.79
gQ =	3.40 (CI 6.5.8.2)	lz-bar =	0.20
gv =	3.40 (CI 6.5.8.2)	Q =	0.78
c =	0.30 (Table 6-2)	Gf =	1.00



SHEET NO. _____
 PROJECT NO. 087237.10
 DATE 1/23/09
 BY AD
 CHECKED BY _____

CLIENT Pacific Earthquake Engineering Research Center
 SUBJECT Wind Pressures In Long Normal Direction for LA BRBF Bldg

Exposure :	B	Topographic Factor		Parapet Pressure	
Basic Wind Speed (V):	85 mph (Fig 6-1)	K1 =	0 (Fig 6-4)	Kz-parapet=	1.61 (Case 1 Table 6-3)
Importance Factor (I) :	1 (Table 1-1, 6-1)	K2 =	0 (Fig 6-4)	qz=qp =	25.3
zg =	1200 ft (Table 6-2)	K3 =	0 (Fig 6-4)	pp =	37.9 psf
α =	7 (Table 6-2)	Kzt =	1		
Kd =	0.85 (Table 6-4)	Gf =	1.00		
h (Mean roof Height) =	544.4 ft	qh =	25.2 psf		
Cp(windward) =	0.8 (Fig 6-6)				
GCpi =	0.18 (Fig 6-5 for Encl. Bldg.)				
	-0.18 (Fig 6-5 for Encl. Bldg.)				
Parapet Tip Height =	551 ft				
GCpn =	1.5 (6.5.12.2.4)				

Elevation (z)	Main Wind Force Resisting System							
	B	L	Kz	qz	Windward Pr.	Internal Pressure		Leeward Pr.
						Positive	Negative	
0	170	107	0.57	9.04	7.20	4.54	-4.54	-12.56
15	170	107	0.57	9.04	7.20	4.54	-4.54	-12.56
20	170	107	0.62	9.81	7.82	4.54	-4.54	-12.56
25	170	107	0.67	10.46	8.34	4.54	-4.54	-12.56
30	170	107	0.70	11.01	8.78	4.54	-4.54	-12.56
40	170	107	0.76	11.96	9.53	4.54	-4.54	-12.56
50	170	107	0.81	12.75	10.16	4.54	-4.54	-12.56
60	170	107	0.85	13.43	10.70	4.54	-4.54	-12.56
70	170	107	0.89	14.03	11.19	4.54	-4.54	-12.56
80	170	107	0.93	14.58	11.62	4.54	-4.54	-12.56
90	170	107	0.96	15.08	12.02	4.54	-4.54	-12.56
100	170	107	0.99	15.54	12.39	4.54	-4.54	-12.56
120	170	107	1.04	16.37	13.05	4.54	-4.54	-12.56
140	170	107	1.09	17.10	13.64	4.54	-4.54	-12.56
160	170	107	1.13	17.77	14.17	4.54	-4.54	-12.56
180	170	107	1.17	18.38	14.65	4.54	-4.54	-12.56
200	170	107	1.20	18.94	15.10	4.54	-4.54	-12.56
250	170	107	1.28	20.19	16.09	4.54	-4.54	-12.56
300	170	107	1.35	21.27	16.95	4.54	-4.54	-12.56
350	170	107	1.41	22.22	17.72	4.54	-4.54	-12.56
400	170	107	1.47	23.09	18.41	4.54	-4.54	-12.56
450	170	107	1.52	23.88	19.04	4.54	-4.54	-12.56
500	170	107	1.57	24.61	19.62	4.54	-4.54	-12.56
550	170	107	1.61	25.29	20.16	4.54	-4.54	-12.56



SHEET NO. _____

PROJECT NO. 087237.10

DATE 1/23/09

CLIENT Pacific Earthquake Engineering Research Center

BY AD

SUBJECT Story Wind Forces in Long Normal Dir. for LA BRBF Bldg

CHECKED BY _____

B_y = 170 ft

e_y = 25.5 ft

Floor	Height	Cum Ht.	Wind Pressure		Story Force (KIPS)	M _T (KIP-IN)
			Windward	Leeward		
Story40	13.5	544.5	20.10	-12.56	74.96	22937.76
Story39	13.5	531	19.95	-12.56	74.63	22836.78
Story38	13.5	517.5	19.81	-12.56	74.29	22732.74
Story37	13.5	504	19.66	-12.56	73.96	22631.76
Story36	13.5	490.5	19.51	-12.56	73.60	22521.60
Story35	13.5	477	19.35	-12.56	73.24	22411.44
Story34	13.5	463.5	19.19	-12.56	72.88	22301.28
Story33	13.5	450	19.04	-12.56	72.52	22191.12
Story32	13.5	436.5	18.87	-12.56	72.13	22071.78
Story31	13.5	423	18.70	-12.56	71.74	21952.44
Story30	13.5	409.5	18.53	-12.56	71.35	21833.10
Story29	13.5	396	18.35	-12.56	70.95	21710.70
Story28	13.5	382.5	18.16	-12.56	70.52	21579.12
Story27	13.5	369	17.98	-12.56	70.10	21450.60
Story26	13.5	355.5	17.79	-12.56	69.67	21319.02
Story25	13.5	342	17.60	-12.56	69.21	21178.26
Story24	13.5	328.5	17.39	-12.56	68.74	21034.44
Story23	13.5	315	17.18	-12.56	68.27	20890.62
Story22	13.5	301.5	16.98	-12.56	67.80	20746.80
Story21	13.5	288	16.75	-12.56	67.27	20584.62
Story20	13.5	274.5	16.51	-12.56	66.74	20422.44
Story19	13.5	261	16.28	-12.56	66.20	20257.20
Story18	13.5	247.5	16.04	-12.56	65.65	20088.90
Story17	13.5	234	15.78	-12.56	65.04	19902.24
Story16	13.5	220.5	15.51	-12.56	64.42	19712.52
Story15	13.5	207	15.24	-12.56	63.81	19525.86
Story14	13.5	193.5	14.95	-12.56	63.15	19323.90
Story13	13.5	180	14.65	-12.56	62.46	19112.76
Story12	13.5	166.5	14.32	-12.56	61.71	18883.26
Story11	13.5	153	13.98	-12.56	60.92	18641.52
Story10	13.5	139.5	13.62	-12.56	60.10	18390.60
Story9	13.5	126	13.23	-12.56	59.19	18112.14
Story8	13.5	112.5	12.80	-12.56	58.21	17812.26
Story7	13.5	99	12.35	-12.56	57.18	17497.08
Story6	13.5	85.5	11.84	-12.56	56.01	17139.06
Story5	13.5	72	11.27	-12.56	54.71	16741.26
Story4	13.5	58.5	10.62	-12.56	53.21	16282.26
Story3	13.5	45	9.85	-12.56	51.43	15737.58
Story2	13.5	31.5	8.89	-12.56	49.25	15070.50
Story1	18	18	7.57	-12.56	61.62	18855.72
Ground	12	0	7.20	-12.56	0.00	0.00
B1	12					
B2	12					
B3	12					
				Σ=	2628.84	

CLIENT Pacific Earthquake Engineering Research Center

SUBJECT Modal Information for Code Elastic Model of LA BRBF Bldg

SHEET NO. _____

PROJECT NO. 087237.10

DATE 1/23/09

BY AD

CHECKED BY _____

Mode	Period (second)	Participation Factor		Σ Participation Factor	
		Ux	Uy	Ux	Uy
1	5.05	0.00	34.40	0.00	34.40
2	3.62	43.98	0.00	43.98	34.40
3	3.53	0.00	0.00	43.98	34.40
4	1.38	0.00	15.06	43.98	49.46
5	1.19	10.99	0.00	54.96	49.46
6	1.15	0.00	0.00	54.96	49.46
7	0.72	0.00	6.71	54.96	56.17
8	0.65	3.32	0.00	58.28	56.17
9	0.64	0.00	0.00	58.28	56.17
10	0.47	0.00	2.90	58.28	59.07
11	0.44	1.71	0.00	59.99	59.07
12	0.44	0.00	0.00	59.99	59.07
13	0.35	0.00	1.51	59.99	60.58
14	0.34	1.19	0.00	61.18	60.58
15	0.33	0.00	0.00	61.18	60.58
16	0.27	0.89	0.00	62.06	60.58
17	0.27	0.00	1.11	62.06	61.70
18	0.26	0.00	0.00	62.06	61.70
19	0.23	0.79	0.00	62.85	61.70
20	0.23	0.00	1.17	62.85	62.86
21	0.21	0.00	0.00	62.85	62.86
22	0.19	0.74	0.00	63.59	62.86
23	0.19	0.00	1.16	63.59	64.02
24	0.18	0.00	0.00	63.59	64.02
25	0.17	0.85	0.00	64.44	64.02
26	0.17	0.00	1.15	64.44	65.17
27	0.16	0.00	0.00	64.44	65.17
28	0.15	0.00	1.36	64.44	66.53
29	0.15	1.00	0.00	65.45	66.53
30	0.14	0.00	0.00	65.45	66.53
31	0.13	1.43	0.00	66.88	66.53
32	0.13	0.00	1.41	66.88	67.95
33	0.13	0.00	0.00	66.88	67.95
34	0.12	2.55	0.00	69.43	67.95
35	0.12	0.00	3.32	69.43	71.26
36	0.12	0.00	0.00	69.43	71.26
37	0.11	6.45	0.00	75.88	71.26
38	0.11	0.00	7.95	75.88	79.21
39	0.11	0.00	0.00	75.88	79.21
40	0.11	10.94	0.00	86.82	79.21
41	0.11	0.00	9.10	86.82	88.32
42	0.10	5.31	0.00	92.13	88.32
43	0.10	0.00	3.88	92.13	92.20
44	0.10	0.00	0.00	92.13	92.20
45	0.09	1.74	0.00	93.87	92.20
46	0.09	0.00	1.65	93.87	93.85
47	0.09	0.00	0.00	93.87	93.85
48	0.09	0.57	0.00	94.44	93.85
49	0.09	0.00	0.68	94.44	94.53
50	0.08	0.00	0.00	94.44	94.53

V = **0.04335** W₁-----(85% of Static Base Shear)
k = **2**
S_{D5} = **1.145**
S_{D1} = **0.52**

Floor	Height	Cumu Ht	Area	Perimeter	Seismic Flat Load (psf)	Seismic Line Load (kip/ft)	Addl. Loading (kips)	Total Wt.	wi*hi^k	Cvx	Equivalent Force		Diaphragm Design Force			
											Fx (kips)	Vx (kips)	Fpx (kips)	Fpx (kips)	Fpx (kips)	Fpx (kips)
													Eq(12.10-1)	Minimum	Maximum	Adopted
Story40	13.5	544.5	18190	554	94	0.203	100	1922.32	569930507.1	0.0753	263.94	263.94	263.94	440.21	880.42	440.21
Story39	13.5	531	18190	554	88	0.203		1713.18	483050509.9	0.0638	223.71	487.65	229.80	392.32	784.64	392.32
Story38	13.5	517.5	18190	554	88	0.203		1713.18	458800847	0.0606	212.48	700.13	224.25	392.32	784.64	392.32
Story37	13.5	504	18190	554	88	0.203		1713.18	435175638.9	0.0575	201.54	901.66	218.74	392.32	784.64	392.32
Story36	13.5	490.5	18190	554	88	0.203		1713.18	412174885.7	0.0545	190.88	1092.54	213.30	392.32	784.64	392.32
Story35	13.5	477	18190	554	88	0.203		1713.18	389798587.3	0.0515	180.52	1273.07	207.95	392.32	784.64	392.32
Story34	13.5	463.5	18190	554	88	0.203		1713.18	368046743.7	0.0486	170.45	1443.51	202.68	392.32	784.64	392.32
Story33	13.5	450	18190	554	88	0.203		1713.18	346919355	0.0459	160.66	1604.18	197.51	392.32	784.64	392.32
Story32	13.5	436.5	18190	554	92	0.203		1785.94	340279547.6	0.0450	157.59	1761.76	200.40	408.98	817.96	408.98
Story31	13.5	423	18190	554	92	0.203		1785.94	319556816.1	0.0422	147.99	1909.75	195.05	408.98	817.96	408.98
Story30	13.5	409.5	18190	554	92	0.203		1785.94	299485060.5	0.0396	138.70	2048.45	189.83	408.98	817.96	408.98
Story29	13.5	396	18190	554	92	0.203		1785.94	280064280.7	0.0370	129.70	2178.15	184.73	408.98	817.96	408.98
Story28	13.5	382.5	18190	554	92	0.203		1785.94	261294476.7	0.0345	121.01	2299.16	179.75	408.98	817.96	408.98
Story27	13.5	369	18190	554	96	0.203		1858.70	253082723	0.0334	117.21	2416.37	181.81	425.64	851.29	425.64
Story26	13.5	355.5	18190	554	96	0.203		1858.70	234903223.4	0.0310	108.79	2525.15	176.70	425.64	851.29	425.64
Story25	13.5	342	18190	554	96	0.203		1858.70	217401220.7	0.0287	100.68	2625.83	171.73	425.64	851.29	425.64
Story24	13.5	328.5	18190	554	96	0.203		1858.70	200576714.9	0.0265	92.89	2718.72	166.89	425.64	851.29	425.64
Story23	13.5	315	18190	554	102	0.203		1967.84	195259122.5	0.0258	90.43	2809.15	171.43	450.64	901.27	450.64
Story22	13.5	301.5	18190	554	102	0.203		1967.84	178881265.4	0.0236	82.84	2891.99	166.33	450.64	901.27	450.64
Story21	13.5	288	18190	554	102	0.203		1967.84	163220686.8	0.0216	75.59	2967.58	161.40	450.64	901.27	450.64
Story20	13.5	274.5	18190	554	102	0.203		1967.84	148277386.7	0.0196	68.67	3036.25	156.61	450.64	901.27	450.64
Story19	13.5	261	18190	554	107	0.203		2058.79	140246969.8	0.0185	64.95	3101.20	158.79	471.46	942.93	471.46
Story18	13.5	247.5	18190	554	107	0.203		2058.79	126113877.5	0.0167	58.40	3159.61	153.90	471.46	942.93	471.46
Story17	13.5	234	18190	554	107	0.203		2058.79	112731214.8	0.0149	52.21	3211.81	149.17	471.46	942.93	471.46
Story16	13.5	220.5	18190	554	107	0.203		2058.79	100098981.7	0.0132	46.36	3258.17	144.61	471.46	942.93	471.46
Story15	13.5	207	18190	554	107	0.203		2058.79	88217178.41	0.0117	40.85	3299.03	140.20	471.46	942.93	471.46
Story14	13.5	193.5	18190	554	115	0.203		2204.31	82534400.98	0.0109	38.22	3337.25	145.24	504.79	1009.57	504.79
Story13	13.5	180	18190	554	115	0.203		2204.31	71419708.8	0.0094	33.08	3370.32	140.56	504.79	1009.57	504.79
Story12	13.5	166.5	18190	554	115	0.203		2204.31	61108488.34	0.0081	28.30	3398.62	136.07	504.79	1009.57	504.79
Story11	13.5	153	18190	554	115	0.203		2204.31	51600739.61	0.0068	23.90	3422.52	131.75	504.79	1009.57	504.79
Story10	13.5	139.5	18190	554	115	0.203		2204.31	42896462.6	0.0057	19.87	3442.39	127.60	504.79	1009.57	504.79
Story9	13.5	126	18190	554	120	0.203		2295.26	36439579.51	0.0048	16.88	3459.26	128.56	525.61	1051.23	525.61
Story8	13.5	112.5	18190	554	120	0.203		2295.26	29049409.69	0.0038	13.45	3472.72	124.43	525.61	1051.23	525.61
Story7	13.5	99	18190	554	120	0.203		2295.26	22495862.86	0.0030	10.42	3483.13	120.49	525.61	1051.23	525.61
Story6	13.5	85.5	18190	554	120	0.203		2295.26	16778939.04	0.0022	7.77	3490.90	116.72	525.61	1051.23	525.61
Story5	13.5	72	18190	554	120	0.203		2295.26	11898638.21	0.0016	5.51	3496.41	113.12	525.61	1051.23	525.61
Story4	13.5	58.5	18190	554	127	0.203		2422.59	8290715.472	0.0011	3.84	3500.25	115.58	554.77	1109.55	554.77
Story3	13.5	45	18190	554	127	0.203		2422.59	4905748.8	0.0006	2.27	3502.53	111.96	554.77	1109.55	554.77
Story2	13.5	31.5	18190	554	127	0.203		2422.59	2403816.912	0.0003	1.11	3503.64	108.53	554.77	1109.55	554.77
Story1	18	18	18190	554	137	0.233		2621.11	849240.288	0.0001	0.39	3504.03	113.63	600.23	1200.47	600.23
Ground	0	0	49940		506.85			25312.09	0	0.0000	0.00					
B1	0	0	49940		86			4294.84	0	0.0000	0.00					
B2	0	0	49940		86			4294.84	0	0	0.00					
B3	0	0	49940		86			4294.84	0	0.0000	0.00					
								80831.20	7566259573.01			3504.03				

CLIENT Pacific Earthquake Engineering Research Center
 SUBJECT Redundancy Calculation for LA BRBF Bldg

X Direction Motion

Model: **121908Model1Rddn_X**

Case: **EQXPL**

Story	Height	Point	Disp	Drift	Point	Disp	Drift	Max/Avg-Drift	Verdict
Story40	13.5	52	18.981	0.372	54	23.401	0.580	1.218	Tor Irr
Story39	13.5	52	18.608	0.411	54	22.821	0.615	1.199	No Tor Irr
Story38	13.5	52	18.198	0.447	54	22.207	0.648	1.18	No Tor Irr
Story37	13.5	52	17.750	0.457	54	21.559	0.660	1.18	No Tor Irr
Story36	13.5	52	17.293	0.484	54	20.899	0.684	1.17	No Tor Irr
Story35	13.5	52	16.809	0.504	54	20.214	0.705	1.17	No Tor Irr
Story34	13.5	52	16.305	0.486	54	19.509	0.689	1.17	No Tor Irr
Story33	13.5	52	15.819	0.500	54	18.820	0.700	1.17	No Tor Irr
Story32	13.5	52	15.319	0.516	54	18.120	0.713	1.16	No Tor Irr
Story31	13.5	52	14.803	0.524	54	17.408	0.720	1.16	No Tor Irr
Story30	13.5	52	14.279	0.507	54	16.688	0.696	1.16	No Tor Irr
Story29	13.5	52	13.772	0.512	54	15.992	0.696	1.15	No Tor Irr
Story28	13.5	52	13.260	0.521	54	15.296	0.697	1.14	No Tor Irr
Story27	13.5	52	12.739	0.532	54	14.599	0.695	1.13	No Tor Irr
Story26	13.5	52	12.207	0.533	54	13.904	0.689	1.13	No Tor Irr
Story25	13.5	52	11.674	0.517	54	13.215	0.669	1.13	No Tor Irr
Story24	13.5	52	11.158	0.516	54	12.546	0.661	1.12	No Tor Irr
Story23	13.5	52	10.642	0.519	54	11.885	0.655	1.12	No Tor Irr
Story22	13.5	52	10.123	0.520	54	11.230	0.650	1.11	No Tor Irr
Story21	13.5	52	9.603	0.521	54	10.580	0.644	1.11	No Tor Irr
Story20	13.5	52	9.082	0.522	54	9.937	0.637	1.10	No Tor Irr
Story19	13.5	52	8.560	0.521	54	9.300	0.628	1.09	No Tor Irr
Story18	13.5	52	8.039	0.519	54	8.672	0.618	1.09	No Tor Irr
Story17	13.5	52	7.520	0.516	54	8.054	0.608	1.08	No Tor Irr
Story16	13.5	52	7.004	0.511	54	7.447	0.596	1.08	No Tor Irr
Story15	13.5	52	6.493	0.506	54	6.850	0.585	1.07	No Tor Irr
Story14	13.5	52	5.987	0.500	54	6.265	0.573	1.07	No Tor Irr
Story13	13.5	52	5.487	0.494	54	5.692	0.559	1.06	No Tor Irr
Story12	13.5	52	4.993	0.486	54	5.133	0.543	1.05	No Tor Irr
Story11	13.5	52	4.507	0.481	54	4.591	0.523	1.04	No Tor Irr
Story10	13.5	52	4.026	0.481	54	4.068	0.497	1.02	No Tor Irr
Story9	13.5	52	3.545	0.471	54	3.571	0.481	1.01	No Tor Irr
Story8	13.5	52	3.074	0.458	54	3.090	0.466	1.01	No Tor Irr
Story7	13.5	52	2.616	0.443	54	2.624	0.450	1.01	No Tor Irr
Story6	13.5	52	2.172	0.427	54	2.175	0.432	1.01	No Tor Irr
Story5	13.5	52	1.745	0.409	54	1.742	0.412	1.00	No Tor Irr
Story4	13.5	52	1.336	0.385	54	1.330	0.387	1.00	No Tor Irr
Story3	13.5	52	0.951	0.354	54	0.944	0.354	1.00	No Tor Irr
Story2	13.5	52	0.598	0.306	54	0.590	0.305	1.00	No Tor Irr
Story1	18	52	0.291	0.268	54	0.286	0.263	1.01	No Tor Irr
Ground	0	52	0.023	0.023	54	0.023	0.023	1.01	No Tor Irr

Case: **EQXMN**

Story	Height	Point	Disp	Drift	Point	Disp	Drift	Max/Avg-Drift	Verdict
Story40	13.5	52	15.793	0.270	54	28.202	0.740	1.465	Extr Tor Irr
Story39	13.5	52	15.522	0.303	54	27.461	0.781	1.441	Extr Tor Irr
Story38	13.5	52	15.219	0.336	54	26.680	0.820	1.418	Extr Tor Irr
Story37	13.5	52	14.883	0.342	54	25.860	0.837	1.419	Extr Tor Irr
Story36	13.5	52	14.540	0.364	54	25.023	0.866	1.408	Extr Tor Irr
Story35	13.5	52	14.176	0.385	54	24.157	0.887	1.395	Tor Irr
Story34	13.5	52	13.791	0.367	54	23.270	0.873	1.408	Extr Tor Irr
Story33	13.5	52	13.424	0.377	54	22.398	0.885	1.402	Extr Tor Irr
Story32	13.5	52	13.047	0.392	54	21.513	0.899	1.393	Tor Irr
Story31	13.5	52	12.655	0.401	54	20.613	0.904	1.386	Tor Irr
Story30	13.5	52	12.254	0.384	54	19.709	0.879	1.391	Tor Irr
Story29	13.5	52	11.870	0.389	54	18.830	0.877	1.385	Tor Irr
Story28	13.5	52	11.481	0.399	54	17.953	0.877	1.374	Tor Irr
Story27	13.5	52	11.081	0.416	54	17.076	0.867	1.351	Tor Irr
Story26	13.5	52	10.665	0.419	54	16.209	0.858	1.344	Tor Irr
Story25	13.5	52	10.246	0.405	54	15.351	0.835	1.347	Tor Irr
Story24	13.5	52	9.842	0.406	54	14.517	0.822	1.339	Tor Irr
Story23	13.5	52	9.436	0.413	54	13.694	0.811	1.325	Tor Irr
Story22	13.5	52	9.022	0.418	54	12.883	0.801	1.314	Tor Irr
Story21	13.5	52	8.604	0.421	54	12.083	0.790	1.305	Tor Irr
Story20	13.5	52	8.183	0.425	54	11.292	0.778	1.294	Tor Irr
Story19	13.5	52	7.758	0.431	54	10.514	0.761	1.277	Tor Irr
Story18	13.5	52	7.327	0.432	54	9.754	0.745	1.266	Tor Irr
Story17	13.5	52	6.895	0.432	54	9.009	0.729	1.256	Tor Irr
Story16	13.5	52	6.463	0.431	54	8.280	0.712	1.246	Tor Irr
Story15	13.5	52	6.032	0.429	54	7.568	0.695	1.236	Tor Irr
Story14	13.5	52	5.603	0.427	54	6.873	0.677	1.226	Tor Irr
Story13	13.5	52	5.176	0.425	54	6.196	0.657	1.215	Tor Irr
Story12	13.5	52	4.751	0.424	54	5.539	0.631	1.196	No Tor Irr
Story11	13.5	52	4.327	0.433	54	4.908	0.594	1.157	No Tor Irr
Story10	13.5	52	3.894	0.462	54	4.314	0.536	1.074	No Tor Irr
Story9	13.5	52	3.432	0.458	54	3.778	0.511	1.055	No Tor Irr
Story8	13.5	52	2.974	0.445	54	3.267	0.494	1.052	No Tor Irr
Story7	13.5	52	2.529	0.431	54	2.772	0.476	1.049	No Tor Irr
Story6	13.5	52	2.098	0.415	54	2.297	0.457	1.048	No Tor Irr
Story5	13.5	52	1.683	0.396	54	1.840	0.435	1.046	No Tor Irr
Story4	13.5	52	1.287	0.373	54	1.405	0.408	1.045	No Tor Irr
Story3	13.5	52	0.914	0.341	54	0.998	0.373	1.044	No Tor Irr
Story2	13.5	52	0.573	0.295	54	0.625	0.322	1.044	No Tor Irr
Story1	18	52	0.278	0.256	54	0.303	0.280	1.045	No Tor Irr
Ground	0	52	0.023	0.023	54	0.023	0.023	1.011	No Tor Irr

V-target= 3626.26 kips(85% of Static Base Shear) Model: 121908Model1
 V-SPECY= 11595.55 kips Scale-X= 3.20
 V-SPECY= 12103.43 kips Scale-Y= 3.34
 p-V dir = 1
 p-Y dir = 1

0.671	0.671	0.671	0.671	0.671	0.671	0.671	0.671	0.671	0.671
1	0.3	-1	-0.3	0.3	1	-1	-0.3		
0.3	1	0.3	1	-1	-0.3	0.3	1		

Story	ETABS #	Section	Capacity	Dead	Live	WindFX	WindMTX	WindFY	WindMTY	SpecX	SpecY	Maximum Axial Loads									Status		
												Tension	Compression	DCR									
Story40	D21	A6	205	-2.48	0.00	0.00	5.15	-6.82	-14.84	74.07	408.13	58.2	127.6	11.9	113.7	-117.0	-15.2	-61.5	-130.9	127.56	-132.78	0.65	OK
Story39	D21	A6	205	-2.51	0.00	0.00	3.57	-13.70	10.31	47.92	405.05	49.7	124.2	19.7	115.2	-118.5	-23.1	-53.1	-127.5	124.17	-129.44	0.63	OK
Story38	D21	A6	205	-2.54	0.00	0.00	2.42	-19.54	7.00	28.59	439.71	46.8	132.7	28.9	127.4	-130.8	-32.3	-50.2	-136.1	132.72	-138.05	0.67	OK
Story37	D21	A6	205	-2.56	0.00	0.00	1.40	-26.19	-4.08	14.89	432.02	41.8	129.1	32.5	126.3	-129.8	-35.9	-45.2	-132.6	129.11	-134.49	0.66	OK
Story36	D21	A6	205	-2.59	0.00	0.00	-0.06	-31.30	-0.10	8.41	429.79	39.5	127.8	34.3	126.2	-129.7	-37.7	-43.0	-131.3	127.82	-133.26	0.65	OK
Story35	D21	A9	308	-2.73	0.00	0.00	-0.87	-40.30	-2.42	18.88	493.91	48.5	147.9	36.7	144.4	-148.0	-40.3	-52.1	-151.6	147.92	-153.65	0.50	OK
Story34	D21	A9	308	-2.76	0.00	0.00	-1.40	-44.44	-3.94	27.33	479.36	49.8	144.3	32.7	139.2	-142.9	-36.4	-53.5	-148.0	144.33	-150.13	0.49	OK
Story33	D21	A9	308	-2.79	0.00	0.00	-3.00	-50.40	-8.53	50.09	517.73	60.3	157.9	29.0	148.5	-152.3	-32.7	-64.1	-161.7	157.94	-163.80	0.53	OK
Story32	D21	A9	308	-2.82	0.00	0.00	4.56	-54.49	-13.02	73.38	542.35	69.8	167.5	23.9	153.7	-157.5	-27.7	-73.6	-171.3	167.48	-173.40	0.56	OK
Story31	D21	A9	308	-2.85	0.00	0.00	-4.81	-52.05	-13.75	77.99	508.20	68.2	157.7	19.4	143.0	-146.9	-32.2	-72.0	-161.5	157.67	-163.64	0.53	OK
Story30	D21	A9	308	-2.87	0.00	0.00	-5.33	-56.61	-15.25	84.31	524.27	71.6	163.1	18.8	147.2	-151.1	-22.7	-75.4	-166.9	163.06	-169.09	0.55	OK
Story29	D21	A9	308	-2.90	0.00	0.00	-6.83	-62.85	-19.55	106.06	572.16	82.6	179.4	16.3	159.5	-163.4	-20.2	-86.5	-183.3	179.43	-185.52	0.60	OK
Story28	D21	A9	308	-2.93	0.00	0.00	-8.03	-67.47	-23.01	123.81	601.21	90.8	189.8	13.4	166.5	-170.5	-17.3	-94.7	-193.7	189.78	-195.93	0.64	OK
Story27	D21	A15.5	530	-2.94	0.00	0.00	-12.25	-110.39	-35.16	187.73	916.40	139.1	290.2	21.7	255.0	-258.9	-25.6	-143.0	-294.1	290.20	-296.37	0.56	OK
Story26	D21	A15.5	530	-2.96	0.00	0.00	-13.58	-116.82	-38.99	206.87	939.73	147.2	299.0	17.8	260.2	-264.1	-21.8	-151.1	-302.9	298.97	-305.19	0.58	OK
Story25	D21	A15.5	530	-2.99	0.00	0.00	-14.75	-126.40	-42.38	224.11	977.13	155.9	311.8	15.7	269.7	-273.7	-19.7	-159.9	-315.8	311.77	-318.06	0.60	OK
Story24	D21	A15.5	530	-3.02	0.00	0.00	-16.41	-135.74	-47.16	248.37	1022.60	167.6	327.7	12.2	281.0	-285.1	-16.3	-171.6	-331.7	327.65	-333.99	0.63	OK
Story23	D21	A15.5	633	-2.99	0.00	0.00	-19.97	-165.11	-57.42	301.79	1206.44	200.8	387.8	12.1	331.1	-335.1	-16.1	-204.8	-391.8	387.76	-394.04	0.62	OK
Story22	D21	A18.5	633	-3.02	0.00	0.00	-22.03	-176.00	-63.39	333.64	1266.12	216.1	408.6	7.4	346.0	-350.1	-11.5	-220.2	-412.7	408.61	-414.95	0.66	OK
Story21	D21	A18.5	633	-2.93	0.00	0.00	-23.92	-184.25	-68.85	362.35	1320.93	230.1	427.8	3.4	359.8	-363.7	-7.4	-234.0	-431.7	427.79	-433.94	0.69	OK
Story20	D21	A18.5	633	-2.95	0.00	0.00	-25.21	-191.83	-72.60	382.17	1354.99	239.3	439.8	0.3	368.1	-372.1	-4.3	-243.3	-443.8	439.84	-446.04	0.70	OK
Story19	D21	A25	855	-2.95	0.00	0.00	-31.75	-250.74	-91.48	482.88	1724.45	304.0	560.0	2.0	469.4	-473.3	-6.0	-308.0	-563.9	559.98	-566.17	0.66	OK
Story18	D21	A25	855	-2.98	0.00	0.00	-33.30	-258.09	-96.00	508.21	1781.60	317.1	579.5	-0.8	484.1	-488.1	-3.2	-321.1	-583.5	579.46	-585.71	0.69	OK
Story17	D21	A25	855	-2.94	0.00	0.00	-35.55	-269.41	-102.51	543.60	1875.35	336.6	610.9	-3.4	508.9	-512.8	-0.5	-340.5	-614.8	610.90	-617.06	0.72	OK
Story16	D21	A25	855	-2.96	0.00	0.00	-38.35	-286.04	-110.63	587.66	1995.09	361.1	650.9	-6.4	540.6	-544.6	2.5	-365.1	-654.9	650.89	-657.10	0.77	OK
Story15	D21	A25	855	-2.89	0.00	0.00	-40.48	-297.65	-116.84	621.36	2097.27	380.9	684.7	-7.8	568.1	-572.0	3.9	-384.8	-688.6	684.71	-690.78	0.81	OK
Story14	D21	A25	855	-2.92	0.00	0.00	-43.13	-313.02	-124.55	663.87	2224.06	405.6	726.7	-9.7	602.1	-606.0	5.8	-409.5	-730.6	726.67	-732.79	0.86	OK
Story13	D21	A25	855	-2.94	0.00	0.00	-45.20	-323.11	-130.58	698.01	2331.22	425.8	762.0	-10.7	631.0	-634.9	6.8	-429.8	-765.9	761.96	-768.14	0.90	OK
Story12	D21	A25	855	-2.97	0.00	0.00	-44.04	-312.55	-127.31	682.78	2314.95	419.6	755.6	-7.4	627.5	-631.5	3.5	-423.6	-759.6	755.64	-761.87	0.89	OK
Story11	D21	A25	855	-2.93	0.00	0.00	-30.69	-238.17	-88.89	478.83	1853.52	314.4	598.3	14.9	508.4	-512.4	-18.8	-318.3	-602.2	598.28	-604.44	0.71	OK
Story10	D21	A15.5	530	-2.88	0.00	0.00	4.31	-33.28	12.18	62.57	608.73	72.3	186.3	33.2	174.6	-178.4	-37.1	-76.2	-190.2	186.31	-192.37	0.36	OK
Story9	D21	A15.5	530	-2.84	0.00	0.00	5.86	-17.60	16.64	85.33	666.67	84.7	205.8	31.3	189.8	-193.6	-35.1	-88.5	-209.6	205.84	-211.80	0.40	OK
Story8	D21	A15.5	530	-2.86	0.00	0.00	2.62	-33.18	7.27	34.11	610.41	63.6	184.2	42.3	177.8	-181.6	-46.1	-67.5	-188.0	184.16	-190.17	0.36	OK
Story7	D21	A15.5	530	-2.82	0.00	0.00	-0.08	-46.56	0.06	6.15	586.59	52.8	174.4	48.9	173.3	-177.1	-52.7	-56.5	-178.2	174.43	-180.35	0.34	OK
Story6	D21	A15.5	530	-2.84	0.00	0.00	-2.71	-42.17	-8.16	50.60	686.70	75.6	208.6	44.0	199.1	-202.9	-47.8	-79.5	-212.4	208.58	-214.55	0.40	OK
Story5	D21	A15.5	530	-2.86	0.00	0.00	-5.36	-76.94	-15.82	92.92	782.03	97.4	241.1	39.3	223.7	-227.5	-43.2	-101.3	-244.9	241.10	-247.11	0.47	OK
Story4	D21	A15.5	530	-2.89	0.00	0.00	-7.73	-89.32	-22.67	130.69	862.58	116.5	268.8	34.7	244.2	-248.1	-38.6	-120.3	-272.6	268.76	-274.82	0.52	OK
Story3	D21	A15.5	530	-2.85	0.00	0.00	-9.60	-97.13	-28.08	160.69	917.31	130.8	288.0	30.3	257.8	-261.7	-34.1	-134.6	-291.8	288.00	-293.98	0.55	OK
Story2	D21	A15.5	530	-2.87	0.00	0.00	-10.94	-98.63	-31.97	182.24	931.67	138.8	294.3	24.8	260.1	-264.0	-28.7	-142.7	-298.2	294.31	-300.33	0.57	OK
Story1	D21	A15.5	530	-2.74	0.00	0.00	-8.70	-70.14	-25.44	145.17	703.64	106.8	222.6	16.0	195.4	-199.0	-19.7	-110.5	-226.3	222.60	-228.34	0.43	OK
Ground	D21	A15.5	530	-3.03	0.00	0.00	4.98	-32.99	14.34	75.51	240.00	43.2	77.0	-4.1	62.8	-66.9	0.0	-47.2	-81.0	76.96	-83.32	0.16	OK
B1	D21	A15.5	530	-2.99	0.00	0.00	3.32	-22.92	9.56	49.69	166.48	28.5	52.5	-2.6	43.2	-47.2	-1.4	-32.5	-56.5	52.54	-58.81	0.11	OK
B2	D21	A15.5	530	-3.01	0.00	0.00	1.61	-9.90	-4.64	23.49	89.54	13.4	27.0	-1.3	22.6	-26.6	-2.7	-17.4	-31.1	27.01	-33.34	0.06	OK
B3	D21	A15.5	530	-3.04	0.00	0.00	-0.13	-4.43	-0.37	3.48	43.53	3.0	11.3	0.8	10.7	-14.8	-4.9	-7.0	-15.4	11.33	-17.71	0.03	OK

Story	ETABS #	Section	Capacity	Dead	Live	WindFX	WindMTX	WindFY	WindMTY	SpecX	SpecY	Maximum Axial Loads									Status		
												Tension	Compression	DCR									
Story40	D22	A6	205	-2.48	0.00	0.00	5.15	-6.82	-14.84	74.07	408.13	58.2	127.6	11.9	113.7	-117.0	-15.2	-61.5	-130.9	127.56	-132.78	0.65	OK
Story39	D22	A6	205	-2.51	0.00	0.00	-3.57	-13.70	-10.31	47.92	405.05	49.7	124.2	19.7	115.2	-118.5	-23.1	-53.1	-127.5	124.17	-129.44	0.63	OK
Story38	D22	A6	205	-2.54	0.00	0.00	2.42	-19.54	7.00	28.59	439.71	46.8	132.7	28.9	127.4	-130.8	-32.3	-50.2	-136.1	132.72	-138.05	0.67	OK
Story37	D22	A6	205	-2.56	0.00	0.00	-1.40	-26.19	-4.08	14.89	432.02	41.8	129.1	32.5	126.3	-129.8	-35.9	-45.2	-132.6	129.11	-134.49	0.66	OK
Story36	D22	A6	205	-2.59	0.00	0.00	0.06	-31.30	0.10	8.41	429.79	39.5	127.8	34.3	126.2	-129.7	-37.7	-43.0	-131.3	127.82	-133.26	0.65	OK
Story35	D22	A9	308																				

Story	ETABS #	Section	Capacity	Dead	Live	WindFX	WindMTX	WindFY	WindMTY	SpecX	SpecY	Maximum Axial Loads							Status				
												Tension	Compression	DCR	Tension	Compression	DCR	Tension		Compression	DCR		
Story10	D26	A25	855	13.78	0.00	0.00	46.04	-462.24	132.87	712.85	2516.92	458.4	830.2	12.5	696.5	-678.0	6.0	-439.9	-811.7	840.66	-811.71	0.98	OK
Story9	D26	A25	855	11.63	0.00	0.00	35.36	-370.11	102.12	549.78	2000.87	359.6	658.9	15.7	555.7	-540.1	-0.1	-344.0	-643.2	667.67	-643.25	0.78	OK
Story8	D26	A25	855	9.91	0.00	0.00	33.10	-336.27	95.64	516.59	1871.75	336.4	615.9	13.3	519.0	-505.7	0.0	-323.1	-602.6	623.42	-602.60	0.73	OK
Story7	D26	A27	923	9.48	0.00	0.00	33.60	-335.13	97.14	526.47	1916.35	343.2	629.9	14.0	531.1	-518.4	-1.2	-330.5	-617.2	637.09	-617.18	0.69	OK
Story6	D26	A27	923	8.12	0.00	0.00	32.79	-318.99	94.87	516.33	1887.55	336.6	619.4	13.6	522.5	-511.6	-2.7	-325.7	-608.5	625.57	-608.51	0.68	OK
Story5	D26	A27	923	6.69	0.00	0.00	32.27	-305.57	93.41	510.53	1878.25	333.0	615.1	13.7	519.3	-510.3	-4.7	-324.0	-606.1	620.20	-606.14	0.67	OK
Story4	D26	A27	923	5.47	0.00	0.00	32.01	-294.73	92.73	508.84	1882.96	332.0	615.6	13.8	520.1	-512.7	-6.4	-324.7	-608.2	619.70	-608.21	0.67	OK
Story3	D26	A27	923	4.18	0.00	0.00	31.55	-280.93	91.49	504.04	1868.15	328.3	609.8	13.1	515.2	-509.6	-7.5	-322.7	-604.2	612.97	-604.19	0.66	OK
Story2	D26	A27	923	2.99	0.00	0.00	30.76	-261.35	89.28	493.74	1875.51	319.6	592.3	10.8	499.6	-495.6	-8.8	-315.6	-588.3	594.54	-588.25	0.64	OK
Story1	D26	A27	923	1.96	0.00	0.00	25.36	-202.06	73.68	408.85	1483.35	262.5	484.1	6.8	407.4	-404.7	-4.2	-299.9	-481.5	485.59	-481.46	0.53	OK
Ground	D26	A18.5	633	-2.64	0.00	0.00	-0.95	1.03	-2.77	14.21	64.52	8.5	18.9	-0.4	16.2	-19.8	-3.1	-12.0	-22.4	18.89	-24.44	0.04	OK
B1	D26	A18.5	633	-3.59	0.00	0.00	-0.66	1.94	-1.93	9.25	59.65	5.8	16.3	0.1	14.6	-19.4	-4.9	-10.7	-21.2	16.33	-23.87	0.04	OK
B2	D26	A18.5	633	-4.58	0.00	0.00	-0.32	-0.36	-0.92	3.74	42.45	1.9	10.0	-0.4	9.3	-15.4	-5.7	-8.1	-16.1	10.00	-19.62	0.03	OK
B3	D26	A18.5	633	-5.55	0.00	0.00	0.07	-4.13	0.22	2.73	43.91	1.1	9.7	-0.6	9.2	-16.6	-6.8	-8.5	-17.1	9.69	-21.34	0.03	OK

Story	ETABS #	Section	Capacity	Dead	Live	WindFX	WindMTX	WindFY	WindMTY	SpecX	SpecY	Maximum Axial Loads							Status				
												Tension	Compression	DCR	Tension	Compression	DCR	Tension		Compression	DCR		
Story10	D27	A25	855	13.78	0.00	0.00	-46.04	462.24	-132.87	712.85	2516.92	458.4	830.2	12.5	696.5	-678.0	6.0	-439.9	-811.7	840.66	-811.71	0.98	OK
Story9	D27	A25	855	11.63	0.00	0.00	-35.36	370.11	-102.12	549.78	2000.87	359.6	658.9	15.7	555.7	-540.1	-0.1	-344.0	-643.2	667.67	-643.25	0.78	OK
Story8	D27	A25	855	9.91	0.00	0.00	-33.10	336.27	-95.64	516.59	1871.75	336.4	615.9	13.3	519.0	-505.7	0.0	-323.1	-602.6	623.42	-602.60	0.73	OK
Story7	D27	A27	923	9.48	0.00	0.00	-33.60	335.13	-97.14	526.47	1916.35	343.2	629.9	14.0	531.1	-518.4	-1.2	-330.5	-617.2	637.09	-617.18	0.69	OK
Story6	D27	A27	923	8.12	0.00	0.00	-32.79	318.99	-94.87	516.33	1887.55	336.6	619.4	13.6	522.5	-511.6	-2.7	-325.7	-608.5	625.57	-608.51	0.68	OK
Story5	D27	A27	923	6.69	0.00	0.00	-32.27	305.57	-93.41	510.53	1878.25	333.0	615.1	13.7	519.3	-510.3	-4.7	-324.0	-606.1	620.20	-606.14	0.67	OK
Story4	D27	A27	923	5.47	0.00	0.00	-32.01	294.73	-92.73	508.84	1882.96	332.0	615.6	13.8	520.1	-512.7	-6.4	-324.7	-608.2	619.70	-608.21	0.67	OK
Story3	D27	A27	923	4.18	0.00	0.00	-31.55	280.93	-91.49	504.04	1868.15	328.3	609.8	13.1	515.2	-509.6	-7.5	-322.7	-604.2	612.97	-604.19	0.66	OK
Story2	D27	A27	923	2.99	0.00	0.00	-30.76	261.35	-89.28	493.74	1875.51	319.6	592.3	10.8	499.6	-495.6	-8.8	-315.6	-588.3	594.54	-588.25	0.64	OK
Story1	D27	A27	923	1.96	0.00	0.00	-25.36	202.06	-73.68	408.85	1483.35	262.5	484.1	6.8	407.4	-404.7	-4.2	-299.9	-481.5	485.59	-481.46	0.53	OK
Ground	D27	A18.5	633	-2.64	0.00	0.00	0.95	-1.03	2.77	14.21	64.52	8.5	18.9	-0.4	16.2	-19.8	-3.1	-12.0	-22.4	18.89	-24.44	0.04	OK
B1	D27	A18.5	633	-3.59	0.00	0.00	0.66	-1.94	1.93	9.25	59.65	5.8	16.3	0.1	14.6	-19.4	-4.9	-10.7	-21.2	16.33	-23.87	0.04	OK
B2	D27	A18.5	633	-4.58	0.00	0.00	0.32	0.36	0.92	3.74	42.45	1.9	10.0	-0.4	9.3	-15.4	-5.7	-8.1	-16.1	10.00	-19.62	0.03	OK
B3	D27	A18.5	633	-5.55	0.00	0.00	-0.07	4.13	-0.22	2.73	43.91	1.1	9.7	-0.6	9.2	-16.6	-6.8	-8.5	-17.1	9.69	-21.34	0.03	OK

Story	ETABS #	Section	Capacity	Dead	Live	WindFX	WindMTX	WindFY	WindMTY	SpecX	SpecY	Maximum Axial Loads							Status				
												Tension	Compression	DCR	Tension	Compression	DCR	Tension		Compression	DCR		
Story10	D28	A25	855	-24.39	0.00	0.00	46.26	-464.01	133.49	716.18	2527.20	434.8	808.0	-13.2	673.6	-706.3	-19.5	-467.5	-840.7	807.99	-859.21	1.00	Say OK
Story9	D28	A25	855	-22.22	0.00	0.00	35.54	-371.82	102.65	552.63	2010.14	338.6	639.2	-7.1	535.5	-565.3	-22.8	-368.4	-669.0	639.18	-685.86	0.80	OK
Story8	D28	A25	855	-20.54	0.00	0.00	33.30	-338.26	96.23	519.73	1881.96	317.9	598.8	-7.2	501.3	-528.9	-20.4	-345.5	-626.4	598.83	-641.96	0.75	OK
Story7	D28	A27	923	-20.05	0.00	0.00	33.78	-336.90	97.68	529.39	1925.87	325.2	613.2	-5.9	513.9	-540.8	-21.0	-352.1	-640.1	612.20	-655.30	0.71	OK
Story6	D28	A27	923	-18.72	0.00	0.00	32.99	-320.87	95.45	519.43	1897.58	320.4	604.7	-4.4	507.2	-532.4	-20.7	-345.6	-629.8	604.70	-644.00	0.70	OK
Story5	D28	A27	923	-17.26	0.00	0.00	32.46	-307.38	93.97	513.55	1887.89	318.7	602.2	-2.5	505.9	-529.0	-20.7	-341.9	-625.4	602.22	-638.46	0.69	OK
Story4	D28	A27	923	-16.06	0.00	0.00	32.21	-296.63	93.32	512.03	1893.13	319.5	604.5	-0.7	508.4	-529.9	-20.8	-341.1	-626.0	604.46	-638.18	0.69	OK
Story3	D28	A27	923	-14.68	0.00	0.00	31.74	-282.65	92.02	506.94	1877.38	317.4	602.2	-0.4	505.1	-524.8	-20.1	-337.1	-619.9	600.19	-631.01	0.68	OK
Story2	D28	A27	923	-13.51	0.00	0.00	30.96	-263.12	89.84	496.77	1825.15	310.3	584.4	-0.4	491.2	-509.3	-17.8	-328.5	-602.5	584.36	-612.74	0.66	OK
Story1	D28	A27	923	-10.82	0.00	0.00	25.54	-203.71	74.20	411.69	1482.10	255.6	478.4	-1.9	401.2	-415.7	-12.6	-278.1	-492.9	478.41	-501.12	0.54	OK
Ground	D28	A18.5	633	-8.53	0.00	0.00	-0.80	-0.36	-2.33	11.81	59.84	3.4	13.3	-4.0	11.1	-22.5	-7.4	-14.8	-24.8	13.32	-31.22	0.05	OK
B1	D28	A18.5	633	-7.48	0.00	0.00	-0.54	0.80	-1.57	7.31	55.86	2.3	12.4	-2.3	11.0	-21.1	-7.8	-12.3	-22.4	12.41	-28.11	0.04	OK
B2	D28	A18.5	633	-6.51	0.00	0.00	-0.19	-1.49	-0.56	1.83	39.45	-0.2	7.6	-1.4	7.3	-16.0	-7.3	-8.5	-16.4	7.63	-21.29	0.03	OK
B3	D28	A18.5	633	-5.55	0.00	0.00	0.20	-5.26	0.57	4.65	48.45	2.1	11.2	-0.8	10.4	-17.8	-6.6	-9.5	-18.7	11.23	-22.89	0.04	OK

V target= 3626.76 kips(85% of Static Base Shear)
V-SPECY= 11595.55 kips Scale-X= 3.20
V-SPECY= 12103.43 kips Scale-Y= 3.34
SDS = 1.145
p-X dir = 1
p-Y dir = 1

Model: 121908Model1

Table with columns for Dead, Live, WindFX, WindFY, WindMTX, WindMTY, SpecX, SpecY. Values range from -3.2 to 1.2.

Main table with columns: Story, ETABS #, Section, Capacity, Dead, Live, WindFX, WindMTX, WindFY, WindMTY, SpecX, SpecY. Rows include Story40, Story39, Story38, Story37, Story36, Story35, Story34, Story33, Story32, Story31, Story30, Story29, Story28, Story27, Story26, Story25, Story24, Story23, Story22, Story21, Story20, Story19, Story18, Story17, Story16, Story15, Story14, Story13, Story12, Story11, Story10, Story9, Story8, Story7, Story6, Story5, Story4, Story3, Story2, Story1, Ground, B1, B2, B3.

Main table with columns: Story, ETABS #, Section, Capacity, Dead, Live, WindFX, WindMTX, WindFY, WindMTY, SpecX, SpecY. Rows include Story40, Story39, Story38, Story37, Story36, Story35, Story34, Story33, Story32, Story31, Story30, Story29, Story28, Story27, Story26, Story25, Story24, Story23, Story22, Story21, Story20, Story19, Story18, Story17, Story16, Story15, Story14, Story13, Story12, Story11, Story10, Story9, Story8, Story7, Story6, Story5, Story4, Story3, Story2, Story1, Ground, B1, B2, B3.

CLIENT Pacific Earthquake Engineering Research Center
 SUBJECT BRB Strength Check along Line 3 for LA BRBF Bldg

V-target= 3636.26 kips(85% of Static Base Shear) Model 121908Model1
 V-SPECK= 11595.55 kips Scale-X= 3.20
 V-SPECY= 12103.43 kips Scale-Y= 3.34
 SDS = 1.145
 p-X dir = 1
 p-Y dir = 1

	0.9	1.429	1.429	1.429	1.429	1.429	1.429	1.429	1.429	1.429	0.671	0.671	0.671	0.671	0.671	0.671	0.671	0.671	0.671
		0.5	0.5	0.5	0.5	0.5	0.5	0.5	0.5	0.5									
-0.9008																			
0.9008																			
-0.9008																			
0.9008																			
	1	0.3	-1	-0.3	0.3	1	-1	-1	-0.3	1	0.3	-1	-0.3	0.3	1	-1	-1	-0.3	-0.3
	0.3	1	0.3	1	-1	-0.3	-0.3	-1	0.3	1	0.3	1	0.3	1	-1	-0.3	-0.3	-1	-1

Story	ETABS #	Section	Capacity	Dead	Live	WindFX	WindMTX	WindFY	WindMTY											Maximum Axial Loads			Status							
										Tension	Compression	DCR																		
Story0	D13	A7	239	-2.57	0.00	0.00	5.98	-10.93	17.19	28.4	68.8	144.8	7.4	126.4	-133.7	-14.8	-76.1	-152.1	70.7	146.7	9.4	128.3	-131.8	-12.8	-74.2	-150.2	146.72	-152.12	0.64	OK
Story9	D13	A7	239	-2.62	0.00	0.01	6.95	-19.09	19.96	39.1	79.9	166.3	8.2	144.8	-152.3	-15.7	-87.4	-173.8	81.9	168.3	10.1	146.8	-150.3	-13.7	-85.4	-171.8	168.29	-173.80	0.73	OK
Story38	D13	A9	308	-2.74	0.00	0.03	9.82	-33.74	28.19	62.1	119.2	252.2	17.5	221.7	-229.5	-25.3	-127.1	-260.1	121.3	254.3	19.5	223.8	-227.5	-23.2	-125.0	-258.0	254.31	-260.06	0.84	OK
Story37	D13	A9	308	-2.79	0.00	0.07	10.65	-44.73	30.56	74.8	127.4	268.4	18.2	235.7	-243.7	-26.2	-135.4	-276.4	129.5	270.6	20.3	237.8	-241.5	-24.1	-133.3	-274.3	270.56	-274.43	0.90	OK
Story26	D13	A9	308	-2.85	0.00	0.11	11.83	-54.14	33.97	87.4	139.4	289.6	17.7	253.1	-261.2	-25.9	-147.5	-297.7	141.5	291.7	19.9	255.2	-259.1	-23.7	-145.3	-295.5	291.72	-297.70	0.97	OK
Story25	D13	A9	308	-2.90	0.00	0.16	-15.02	61.30	-44.63	115.1	162.4	312.1	6.4	261.7	-270.1	-14.8	-166.8	-315.7	160.6	309.5	8.6	264.0	-267.9	-12.6	-164.6	-313.5	309.55	-315.74	0.84	OK
Story34	D13	A11	376	-3.00	0.00	0.22	-15.54	70.77	-44.63	129.1	172.2	327.8	3.4	277.1	-285.6	-11.9	-180.6	-336.2	174.4	330.0	5.6	279.4	-283.3	-9.6	-178.4	-334.0	330.00	-336.21	0.89	OK
Story33	D13	A11	376	-3.01	0.00	0.31	-17.98	91.08	-51.65	147.7	180.7	338.4	0.1	284.2	-292.8	-8.7	-189.3	-347.0	183.0	340.7	2.4	286.5	-290.5	-6.4	-187.0	-344.7	340.69	-347.00	0.92	OK
Story32	D13	A11	376	-3.01	0.00	0.31	-17.98	91.08	-51.65	147.7	180.7	338.4	0.1	284.2	-292.8	-8.7	-189.3	-347.0	183.0	340.7	2.4	286.5	-290.5	-6.4	-187.0	-344.7	340.69	-347.00	0.92	OK
Story31	D13	A13.5	462	-2.95	0.00	0.28	-22.47	109.86	-64.54	180.3	218.8	399.0	-5.4	331.8	-340.2	-3.0	-227.2	-407.5	221.0	401.3	-3.2	334.0	-338.0	-0.8	-225.0	-405.2	401.26	-407.45	0.88	OK
Story30	D13	A13.5	462	-2.99	0.00	0.34	-23.20	119.52	-66.64	185.6	224.0	407.1	-6.5	338.0	-346.5	-2.1	-232.6	-415.7	226.3	409.4	-4.2	340.2	-344.3	0.2	-230.3	-413.4	409.40	-415.68	0.90	OK
Story29	D13	A13.5	462	-2.95	0.00	0.36	-24.60	129.82	-70.70	205.8	234.7	423.5	-8.4	350.6	-359.0	-0.1	-243.1	-431.9	236.9	425.7	-6.1	352.8	-356.8	2.2	-240.9	-429.7	425.71	-431.91	0.94	OK
Story28	D13	A13.5	462	-2.99	0.00	0.43	-25.74	138.37	-73.99	217.6	243.0	435.2	-10.7	359.1	-367.6	2.2	-251.6	-443.8	245.3	437.5	-8.4	361.4	-365.4	4.4	-249.3	-441.5	437.47	-443.76	0.96	OK
Story27	D13	A13.5	462	-2.91	0.00	0.40	-25.16	136.19	-72.34	217.0	239.2	423.1	-14.0	341.1	-349.4	4.6	-242.3	-423.5	236.2	417.4	-10.8	343.3	-347.2	6.9	-240.1	-421.3	417.36	-423.47	0.92	OK
Story26	D13	A13.5	462	-2.95	0.00	0.46	-25.84	144.19	-74.30	223.2	239.2	423.1	-14.0	341.1	-349.4	4.6	-242.3	-423.5	236.2	417.4	-10.8	343.3	-347.2	6.9	-240.1	-421.3	417.36	-423.47	0.92	OK
Story25	D13	A13.5	462	-2.91	0.00	0.47	-26.28	151.63	-75.58	225.3	243.1	430.4	-13.8	353.4	-361.7	5.5	-251.4	-438.8	245.3	432.6	-11.6	355.6	-359.5	7.7	-249.2	-436.6	432.64	-438.76	0.95	OK
Story24	D13	A13.5	462	-2.95	0.00	0.54	-26.79	157.93	-77.09	229.0	247.1	436.9	-14.5	358.4	-366.8	6.0	-255.6	-445.3	249.4	439.1	-12.2	360.7	-364.6	8.3	-253.3	-443.1	439.13	-443.32	0.96	OK
Story23	D13	A13.5	462	-2.91	0.00	0.54	-26.63	158.59	-76.64	228.2	244.8	432.1	-14.8	354.2	-362.5	6.4	-253.1	-440.4	247.0	434.3	-12.6	356.4	-360.3	8.7	-250.9	-438.2	434.28	-440.39	0.95	OK
Story22	D13	A13.5	462	-2.95	0.00	0.61	-26.95	163.47	-77.58	244.6	247.9	437.4	-15.0	358.6	-367.0	6.5	-254.3	-445.8	250.1	439.6	-12.7	360.8	-364.7	8.8	-254.0	-443.6	439.63	-445.81	0.97	OK
Story21	D13	A13.5	462	-2.87	0.00	0.56	-27.21	167.15	-78.36	248.8	250.4	442.9	-14.3	363.5	-371.7	6.1	-258.6	-451.1	252.6	445.1	-12.1	365.7	-369.5	8.2	-256.5	-448.9	445.06	-451.10	0.98	OK
Story20	D13	A13.5	462	-2.91	0.00	0.62	-27.10	169.08	-78.05	249.8	249.8	442.4	-14.0	363.2	-371.5	5.7	-258.1	-450.7	252.0	444.6	-11.8	365.4	-369.3	7.9	-255.9	-448.5	444.56	-450.66	0.98	OK
Story19	D13	A13.5	462	-2.94	0.00	0.69	-25.87	163.29	-74.52	240.8	239.4	424.8	-13.1	349.1	-357.5	4.7	-247.8	-433.2	241.6	427.1	-10.9	351.3	-355.3	6.9	-245.6	-431.0	427.07	-433.24	0.94	OK
Story18	D13	A13.5	462	-2.97	0.00	0.75	-25.56	164.13	-73.66	233.9	238.0	423.9	-12.1	348.9	-357.4	3.6	-246.4	-432.4	240.2	426.1	-9.8	351.1	-355.1	5.8	-244.2	-430.1	426.12	-432.36	0.94	OK
Story17	D13	A13.5	462	-2.93	0.00	0.75	-25.40	164.22	-73.20	241.9	237.9	425.9	-10.6	354.4	-359.7	2.2	-246.3	-434.3	240.1	428.1	-8.3	353.6	-357.5	4.4	-244.0	-432.0	428.11	-434.26	0.94	OK
Story16	D13	A13.5	462	-2.96	0.00	0.82	-25.22	169.30	-72.69	244.1	237.7	427.5	-9.4	353.4	-361.9	0.9	-245.2	-436.0	240.0	429.8	-7.1	355.7	-359.6	3.1	-243.9	-433.8	429.79	-436.01	0.94	OK
Story15	D13	A13.5	462	-2.92	0.00	0.82	-24.95	171.59	-71.96	245.2	237.0	428.6	-7.6	355.2	-363.6	-0.7	-245.3	-436.9	239.2	430.8	-5.4	357.4	-361.4	1.5	-243.1	-434.7	430.82	-436.95	0.95	OK
Story14	D13	A13.5	462	-2.95	0.00	0.88	-24.68	174.25	-71.20	246.8	236.2	429.3	-6.3	356.6	-365.0	-2.1	-244.6	-437.7	238.4	431.5	-4.1	358.8	-362.8	0.1	-242.4	-435.5	431.55	-437.74	0.95	OK
Story13	D13	A13.5	462	-2.98	0.00	0.95	-24.07	172.28	-69.46	243.0	232.3	424.3	-5.0	353.1	-361.6	-3.5	-240.8	-432.8	234.5	426.5	-2.8	355.4	-359.4	-1.2	-238.5	-430.5	426.54	-432.79	0.94	OK
Story12	D13	A13.5	462	-3.01	0.00	1.02	-22.36	157.24	-64.55	223.6	218.0	400.9	-3.4	334.5	-343.1	-5.2	-226.6	-409.5	220.3	403.2	-1.2	336.8	-340.8	-2.9	-224.4	-407.2	403.21	-409.53	0.89	OK
Story11	D13	A13.5	462	-2.96	0.00	1.01	-17.16	-107.38	49.58	153.3	172.8	355.6	1.2	274.2	-282.6	-9.7	-181.3	-334.1	175.0	327.9	3.5	276.4	-280.4	-7.5	-179.0	-331.9	327.89	-334.11	0.72	OK
Story10	D13	A13.5	462	-2.99	0.00	1.08	-4.90	-3.32	-14.24	-17.9	73.6	173.9	19.9	156.8	-166.3	-28.5	-82.2	-182.4	75.9	176.2	22.2	160.1	-164.1	-26.2	-79.9	-180.2	176.16	-182.44	0.40	OK
Story9	D13	A13.5	462	-2.95	0.00	1.08	-3.02	-23.82	-8.81	7.2	60.9	158.7	25.2	148.0	-156.4	-33.6	-69.3	-167.1	63.1	160.9	27.4	150.2	-154.2	-31.4	-67.1	-164.9	160.94	-167.13	0.36	OK
Story8	D13	A13.5	462	-2.98	0.00	1.15	-3.47	-14.92	-10.12	-2.5	64.9	164.8	24.3	152.6	-161.1	-32.8	-73.5	-173.3	67.2	167.1	26.6	154.9	-158.9	-30.6	-71.2	-171.1	167.07	-173.32	0.38	OK
Story7	D13	A13.5	462	-3.00	0.00	1.22	-3.88	-3.29	-11.32	-14.5	68.4	169.6	23.3	156.1	-164.7	-31.9	-77.0	-178.2	70.7	171.9	25.6	158.4	-162.4	-29.6	-74.7	-175.9	171.91	-178.22	0.39	OK
Story6	D13	A13.5	462	-3.03	0.00	1.29	4.51	-11.94	13.13	-30.5	74.0	178.2	22.2	162.7	-171.4	-30.9	-82.7	-186.9	76.3	180.5	24.5	165.0	-169.1	-28.6	-80.4	-184.6	180.54	-186.91	0.40	OK
Story5	D13	A13.5	462	-2.99	0.00	1.29	5.08	-25.72	14.80	-18.7	79.6	187.8	21.9	170.5	-179.0	-30.5	-88.1	-196.3	81.8	190.0	24.2	172.8	-176.8	-28.2	-85.8	-194.1	190.05	-196.32	0.43	OK
Story4	D13	A13.5	462	-3.01	0.00	1.36	-5.60	38.86	-16.32	-58.7	84.7	196.4	21.4	177.4	-186.1	-30.0	-93.3	-205.0	87.0	198.7	23.7	179.7</								

V-target= 3626.26 kips(85% of Static Base Shear)
V-SPECX= 11595.55 kips Scale-X= 3.20
V-SPECY= 12103.43 kips Scale-Y= 3.34
SDS = 1.145
p-X dir = 1
p-Y dir = 1

Model: 121908Model1

Table with 28 columns and 4 rows of numerical data, likely representing structural analysis results for different cases (Case 1, Case 2, Case 3, Case 4).

Main structural analysis table with columns: Story, ETABS #, Section, Capacity, Dead, Live, WindFX, WindMTX, WindFY, WindMTY. Rows include Story40 through Story13 and Ground level.

Main structural analysis table with columns: Story, ETABS #, Section, Capacity, Dead, Live, WindFX, WindMTX, WindFY, WindMTY. Rows include Story40 through Story13 and Ground level.

Story	ETABS #	Section	Capacity	Dead	Live	WindFX	WindMTX	WindFY	WindMTY												Maximum Axial Loads			Status							
																					Tension	Compression	DCR								
Story0	D2	A7	239	-0.20	0.00	-4.11	-9.15	-0.01	-26.30	19.0	-28.4	148.7	113.1	-109.0	37.2	37.8	103.4	-149.3	113.6	148.9	113.2	-103.9	37.4	37.7	103.6	-149.1	-113.5	148.85	-149.27	0.62	OK
Story9	D2	A7	239	-0.27	0.00	-8.38	-9.49	-0.27	-27.27	23.3	-25.8	159.3	118.9	-112.9	37.3	38.6	112.2	-160.0	-119.7	148.9	119.1	-114.5	37.5	37.8	112.4	-159.8	-119.5	159.45	-160.01	0.62	OK
Story8	D2	A7	239	-0.33	0.00	-12.63	-9.79	-0.65	-28.13	27.7	-25.1	192.5	131.2	-144.8	30.0	31.0	143.8	-132.2	-187.3	131.5	-144.5	30.3	30.7	144.1	-152.2	-131.9	192.73	-151.93	0.61	OK	
Story7	D2	A8	274	-0.04	0.00	-16.08	-11.52	0.02	-33.09	33.9	-25.8	211.8	150.1	-154.8	40.1	-40.2	154.7	-212.0	-150.2	211.9	150.2	-154.8	40.2	-40.2	154.8	-211.9	-150.2	211.87	-211.96	0.77	OK
Story6	D2	A8	274	0.11	0.00	-20.02	-11.93	0.12	-34.27	38.0	-23.6	227.3	157.5	-168.6	38.8	-39.1	168.3	-227.6	-157.9	227.4	157.6	-168.5	38.9	-39.0	168.4	-227.5	-157.8	227.60	-227.60	0.83	OK
Story5	D2	A8	274	-0.16	0.00	-23.55	-12.12	-0.42	-34.82	41.1	-20.8	235.4	166.1	-176.5	36.9	-37.4	176.0	-235.8	-166.9	235.5	166.6	-176.4	37.0	-37.3	176.1	-235.7	-166.8	235.49	-235.83	0.86	OK
Story4	D2	A10	342	0.53	0.00	-27.33	-15.30	-1.01	-43.97	50.0	-27.4	266.6	193.4	-190.7	56.2	-54.4	192.2	-265.1	-191.9	266.2	193.0	-191.1	56.8	-56.1	191.8	-265.5	-192.3	266.60	-265.50	0.81	OK
Story3	D2	A10	342	0.59	0.00	-30.57	-15.58	-1.49	-44.79	53.0	-25.0	275.1	197.4	-198.1	55.4	-53.7	199.8	-273.4	-195.7	274.6	196.9	-198.5	55.0	-54.2	199.3	-273.9	-196.1	275.10	-273.86	0.80	OK
Story2	D2	A10	342	0.60	0.00	-34.42	-15.80	-1.98	-45.41	56.4	-21.8	280.3	200.4	-202.3	55.6	-53.9	204.0	-278.6	-198.6	279.9	199.9	-202.8	55.1	-54.3	203.6	-279.1	-199.1	280.31	-279.05	0.82	OK
Story1	D2	A10	342	0.73	0.00	-37.24	-15.75	-2.59	-45.26	58.5	-18.4	282.4	200.7	-204.3	54.7	-52.4	206.4	-286.4	-198.6	281.8	200.1	-204.2	54.1	-53.3	205.9	-280.9	-199.2	282.40	-280.86	0.83	OK
Story0	D2	A13.5	462	2.15	0.00	-41.30	-21.11	-1.46	-60.69	76.4	-25.1	356.1	263.8	-247.9	62.4	-60.4	260.0	-350.0	-264.5	354.5	261.1	-244.4	60.9	-59.6	261.4	-351.6	-259.2	356.11	-351.61	0.71	OK
Story9	D2	A13.5	462	2.32	0.00	-50.40	-21.21	-5.41	-60.98	81.4	-21.7	357.6	265.6	-248.1	81.9	-77.3	254.7	-351.0	-259.0	355.8	263.8	-249.9	82.1	-79.0	253.0	-352.7	-260.7	357.59	-352.71	0.77	OK
Story8	D2	A13.5	462	2.48	0.00	-54.64	-21.19	-6.51	-60.94	84.4	-16.7	353.3	268.0	-252.9	81.2	-76.1	264.0	-356.2	-260.9	351.4	266.1	-254.8	81.3	-79.0	258.1	-358.1	-262.8	363.26	-358.05	0.79	OK
Story7	D2	A13.5	462	2.73	0.00	-58.75	-20.69	-7.76	-61.82	87.4	9.9	365.9	265.5	-255.5	81.6	-78.8	263.1	-358.1	-267.7	358.8	264.5	-258.6	77.7	-74.1	262.3	-360.2	-260.8	365.89	-360.15	0.79	OK
Story6	D2	A13.5	462	2.93	0.00	-61.38	-20.53	-9.10	-59.05	84.4	-5.6	365.1	266.3	-255.2	80.3	-71.9	263.6	-356.7	-258.0	362.8	264.1	-257.4	78.0	-74.1	261.4	-358.9	-260.2	365.05	-358.90	0.79	OK
Story5	D2	A15.5	530	3.75	0.00	-67.81	-23.30	-11.09	-67.04	93.9	-6.9	399.4	296.5	-273.4	96.6	-85.9	284.1	-388.7	-287.7	396.6	296.6	-276.2	93.8	-88.7	281.3	-391.5	-290.6	399.42	-391.54	0.75	OK
Story4	D2	A15.5	530	3.68	0.00	-70.49	-23.02	-11.77	-66.25	95.1	-3.0	397.5	296.0	-272.9	94.9	-84.4	283.4	-387.0	-285.5	394.7	293.2	-275.7	92.1	-87.1	280.6	-389.8	-288.3	397.53	-389.79	0.75	OK
Story3	D2	A15.5	530	3.28	0.00	-74.29	-22.55	-11.22	-64.89	97.9	1.2	396.7	291.0	-278.1	89.1	-79.8	285.5	-387.4	-281.6	394.2	288.5	-278.6	88.6	-82.3	283.0	-389.8	-284.1	396.71	-389.84	0.75	OK
Story2	D2	A15.5	530	2.85	0.00	-78.25	-22.20	-10.68	-63.90	101.0	5.1	397.0	287.3	-279.9	84.2	-76.1	288.0	-388.9	-279.1	394.9	285.1	-282.0	82.1	-78.2	285.9	-391.1	-281.3	397.91	-391.05	0.75	OK
Story1	D2	A15.5	530	2.37	0.00	-81.96	-21.89	-9.61	-63.01	104.3	8.1	397.9	283.7	-284.4	79.0	-72.2	291.2	-391.2	-276.9	396.2	281.9	-289.2	77.2	-74.0	289.4	-393.0	-278.7	397.95	-392.97	0.75	OK
Story0	D2	A15.5	530	1.82	0.00	-85.63	-21.41	-8.30	-61.65	107.5	11.4	397.4	278.5	-288.3	72.8	-67.6	293.5	-392.2	-273.3	396.0	277.1	-289.7	71.4	-69.0	292.2	-393.6	-274.7	397.39	-393.57	0.75	OK
Story9	D2	A15.5	530	1.26	0.00	-89.34	-20.51	-6.87	-59.08	110.2	16.1	394.5	269.9	-291.7	64.1	-60.5	295.4	-390.9	-266.3	393.5	269.0	-292.7	63.1	-61.4	294.4	-391.8	-267.3	394.46	-391.82	0.74	OK
Story8	D2	A15.5	530	0.71	0.00	-93.11	-19.90	-5.31	-57.31	113.4	19.7	394.2	264.4	-296.3	57.2	-55.2	298.4	-392.2	-262.4	393.7	263.8	-296.9	56.7	-55.7	297.8	-392.7	-262.9	394.22	-392.74	0.74	OK
Story7	D2	A15.5	530	0.34	0.00	-96.78	-19.34	-4.18	-55.72	116.6	23.6	394.9	260.1	-300.8	51.4	-50.4	301.7	-393.9	-259.1	394.6	259.8	-301.0	51.1	-50.7	301.5	-394.2	-259.4	394.88	-394.16	0.74	OK
Story6	D2	A15.5	530	-0.11	0.00	-100.52	-18.74	-2.74	-54.01	119.7	27.4	395.3	255.5	-305.2	45.4	-45.7	304.9	-395.6	-255.8	395.4	255.6	-305.1	45.4	-45.6	305.0	-395.5	-255.7	395.36	-395.58	0.75	OK
Story5	D2	A15.5	530	-0.68	0.00	-104.31	-18.11	-1.26	-52.31	122.8	31.1	397.1	251.6	-309.9	39.6	-39.8	309.7	-397.3	-251.9	397.1	251.7	-309.8	39.6	-39.7	309.7	-397.3	-251.8	397.15	-397.33	0.75	OK
Story4	D2	A15.5	530	-1.16	0.00	-108.12	-17.45	-0.29	-50.30	124.4	38.6	398.8	247.4	-315.0	33.7	-33.7	314.5	-399.2	-247.9	399.0	247.5	-314.8	33.4	-33.6	314.6	-399.2	-247.7	398.96	-399.30	0.75	OK
Story3	D2	A15.5	530	-0.26	0.00	-111.97	-16.63	-2.42	-47.95	126.7	44.6	399.8	241.8	-320.0	25.8	-26.6	319.3	-400.5	-242.5	400.0	241.9	-319.8	26.0	-26.4	319.5	-400.3	-242.3	399.46	-400.51	0.75	OK
Story2	D2	A15.5	530	-0.38	0.00	-115.87	-15.39	-2.05	-44.39	128.3	52.0	398.0	232.3	-324.4	15.6	-16.7	323.3	-399.1	-233.4	398.3	232.6	-324.1	15.9	-16.4	323.6	-398.8	-233.1	398.33	-399.13	0.75	OK
Story1	D2	A15.5	530	-0.95	0.00	-119.82	-14.38	-1.19	-41.82	129.1	60.2	398.1	223.2	-328.9	7.9	-8.4	327.1	-398.2	-213.3	398.4	213.0	-325.5	11.2	-12.2	325.0	-398.9	-213.0	398.38	-399.18	0.72	OK
Story0	D2	A15.5	530	-0.49	0.00	-123.49	-8.12	-1.73	-32.46	123.1	83.9	360.7	169.4	-321.4	-35.2	33.8	320.0	-362.1	-170.8	361.1	169.8	-321.1	-34.9	34.2	320.4	-361.7	-170.4	361.09	-362.12	0.68	OK
Story9	D2	A15.5	530	-0.95	0.00	-126.97	-6.91	-0.32	-19.97	119.8	89.6	359.3	159.8	-327.1	-46.1	43.4	324.0	-362.1	-160.6	360.1	160.6	-326.4	-45.4	44.1	325.1	-361.3	-161.8	360.05	-362.05	0.68	OK
Story8	D2	A15.5	530	-1.48	0.00	-130.39	-4.52	1.07	-18.83	128.2	92.3	364.5	158.2	-335.5	-31.8	47.6	331.3	-368.7	-162.4	365.6	159.3	-334.4	-50.7	48.7	332.4	-361.6	-161.3	365.59	-368.69	0.70	OK
Story7	D2	A15.5	530	-1.93	0.00	-133.95	-4.63	1.96	-17.48	136.8	104.8	364.2	154.8	-343.8	-19.8	51.4	339.8	-376.2	-161.1	372.0	159.9	-343.0	-64.6	64.5	341.0	-374.0	-160.0	364.51	-374.01	0.71	OK
Story6	D2	A15.5	530	-1.65	0.00	-137.32	-5.75	0.74	-16.62	137.2	107.4	367.9	151.1	-353.4	-43.3	58.6	348.6	-386.2	-160.8	370.2	157.3	-352.1	-42.0	42.0	349.9	-381.4	-159.6	370.16	-382.63	0.72	OK
Story5	D2	A15.5	530	-2.15	0.00	-139.44	-5.45	1.72	-15.78	138.5	103.0	383.1	155.1	-361.3	-68.2	62.0	355.2	-389.3	-161.3	384.7	156.8	-389.7	-66.6	63.7	356.8	-387.6	-159.7	384.75	-389.27	0.73	OK
Story4	D2	A15.5	530	-2.72	0.00	-139.84	-5.14	2.78	-14.89	134.6	102.8	383.6	152.7	-364.7	-71.8	64.0	357.0	-391.4	-160.5	385.6	154.8	-382.7	-69.7	66.1	359.0	-389.3	-158.4	385.64	-391.35	0.74	OK
Story3	D2	A15.5	530	-3.15	0.00	-138.86	-4.83	3.44	-13.42	141.5	99.4	374.2	147.5	-372.9	-83.2	68.5	348.9	-383.2	-156.5	386.5	149.8	-385.5	-84.8	84.8	351.3	-388.8	-154.1	385.84	-388.17	0.72	OK
Story2	D2	A15.5	530	-3.69	0.00	-124.02	-4.46	4.48	-12.92	120.1	88.7	343.7	135.5	-330.4	-66.7	56.2	319.9	-354.2	-146.0	346.5	138.3	-327.6	-64.0	59.0	322.7	-351.4	-143.2	346.49	-354.23	0.67	OK
Story1	D2	A15.5	530	-3.57	0.00	-82.47	-																								

Story	ETABS #	Section	Capacity	Dead	Live	WindFX	WindMTX	WindFY	WindMY	Maximum Axial Loads														Status							
										Tension	Compression	DCR	Tension	Compression	DCR	Tension	Compression	DCR	Tension	Compression	DCR	Tension	Compression		DCR						
Story0	D41	A7	239	-3.09	0.00	-6.79	-10.17	0.00	-29.22	20.5	-32.1	160.8	119.2	-120.8	34.7	-43.5	112.0	-169.7	-128.0	162.2	121.6	-118.5	37.0	-41.2	114.4	-163.3	-126.7	162.18	-169.66	0.71	OK
Story9	D41	A7	239	-3.13	0.00	-11.11	-10.47	0.00	-30.08	24.9	-29.4	173.6	125.4	-122.5	31.8	-42.7	123.1	-181.4	-134.4	175.9	127.6	-129.7	36.2	-40.4	125.4	-180.1	-132.0	175.94	-181.27	0.76	OK
Story38	D41	A7	239	-3.17	0.00	-15.41	-10.69	0.06	-30.71	29.1	-26.3	204.7	136.4	-162.2	26.3	-35.4	153.2	-213.8	-145.5	201.1	138.8	-159.8	28.7	-33.0	155.6	-211.4	-143.1	207.12	-213.77	0.89	OK
Story7	D41	A10	342	-3.30	0.00	-24.09	-15.53	0.12	-44.62	45.0	-35.6	281.3	194.4	-216.0	45.0	-35.6	206.6	-290.7	-203.8	288.8	196.9	-213.5	47.7	-52.1	209.1	-288.2	-201.3	283.79	-290.72	0.85	OK
Story36	D41	A10	342	-3.34	0.00	-29.16	-15.95	0.19	-45.85	50.4	-32.6	299.0	202.9	-221.7	43.7	-33.2	222.2	-308.6	-212.4	301.5	205.4	-229.2	46.2	-50.7	224.7	-306.0	-209.9	301.54	-308.56	0.89	OK
Story25	D41	A10	342	-3.38	0.00	-33.81	-16.18	0.26	-46.49	55.0	-29.3	308.5	209.9	-230.5	42.2	-31.7	239.8	-318.1	-216.8	311.0	209.5	-237.7	41.8	-49.1	233.4	-315.6	-214.0	311.02	-318.12	0.93	OK
Story24	D41	A13.5	462	-3.49	0.00	-43.20	-22.04	0.41	-63.36	73.4	-41.5	378.1	270.0	-282.6	71.8	-48.1	272.6	-388.1	-280.0	388.8	272.6	-280.0	74.4	-79.1	275.3	-385.5	-277.3	388.79	-388.11	0.84	OK
Story33	D41	A13.5	462	-3.44	0.00	-48.24	-22.57	0.46	-64.88	78.9	-38.8	390.8	277.1	-293.0	72.0	-48.1	283.2	-400.7	-287.0	392.4	279.7	-290.4	74.6	-79.2	285.8	-398.1	-284.3	393.45	-400.67	0.87	OK
Story32	D41	A13.5	462	-3.47	0.00	-54.47	-23.14	0.59	-66.53	85.5	-35.3	402.4	284.6	-302.0	73.2	-48.1	292.1	-416.4	-294.5	405.2	287.2	-299.4	75.8	-80.5	294.8	-409.7	-291.9	405.08	-408.36	0.89	OK
Story21	D41	A13.5	462	-3.39	0.00	-59.24	-23.37	0.53	-67.19	90.3	-31.7	416.1	288.1	-308.7	72.4	-48.1	281.6	-431.7	-297.1	409.6	304.4	-302.4	75.0	-79.5	301.6	-412.2	-295.2	412.68	-416.79	0.91	OK
Story0	D41	A13.5	462	-3.42	0.00	-57.57	-23.67	0.66	-68.05	89.4	-34.4	390.7	284.1	-288.2	80.4	-90.2	278.4	-405.5	-293.8	393.3	286.7	-285.6	83.0	-87.6	281.0	-397.9	-291.3	393.28	-400.46	0.87	OK
Story29	D41	A13.5	462	-3.37	0.00	-61.60	-24.07	0.68	-69.21	93.7	-32.2	396.6	288.3	-292.4	81.6	-91.3	282.7	-406.2	-298.0	399.2	290.9	-289.8	84.2	-88.7	285.3	-403.7	-295.4	399.17	-406.25	0.88	OK
Story28	D41	A13.5	462	-3.40	0.00	-66.84	-24.29	0.80	-69.86	98.7	-28.6	405.2	292.3	-301.7	80.7	-90.2	296.4	-414.9	-300.0	407.8	294.8	-297.6	83.2	-87.8	293.0	-412.3	-299.4	407.79	-414.92	0.90	OK
Story27	D41	A13.5	462	-3.32	0.00	-71.16	-23.95	0.73	-68.89	102.3	-23.2	408.9	290.5	-305.5	82.2	-85.7	296.0	-418.4	-300.0	411.4	293.0	-303.0	83.7	-83.2	296.5	-415.8	-297.5	411.38	-418.36	0.91	OK
Story26	D41	A13.5	462	-3.35	0.00	-74.10	-23.91	0.82	-68.79	104.9	-20.5	408.6	289.9	-305.6	75.7	-85.3	296.0	-418.1	-299.5	410.1	292.5	-303.0	78.2	-82.7	298.5	-415.6	-297.0	411.10	-418.13	0.91	OK
Story25	D41	A15.5	530	-3.40	0.00	-83.01	-27.27	0.93	-78.47	118.7	-24.4	451.0	326.2	-332.6	91.1	-100.8	322.9	-460.8	-335.9	453.6	328.8	-330.1	93.7	-98.3	325.5	-458.2	-333.4	453.62	-460.75	0.87	OK
Story24	D41	A15.5	530	-3.42	0.00	-88.24	-27.05	1.01	-77.88	123.3	-20.8	458.4	324.3	-333.2	89.2	-99.0	323.4	-460.1	-334.0	453.0	328.9	-330.6	91.8	-96.4	326.0	-457.6	-331.4	452.96	-460.15	0.87	OK
Story23	D41	A15.5	530	-3.44	0.00	-90.97	-26.56	1.13	-76.45	124.8	-15.0	452.3	321.2	-337.5	84.3	-94.2	327.6	-462.1	-331.1	454.9	323.9	-334.9	86.9	-91.6	330.2	-459.5	-328.5	454.07	-462.10	0.87	OK
Story22	D41	A15.5	530	-3.47	0.00	-95.85	-26.17	1.24	-75.34	128.6	-9.3	454.9	319.2	-342.1	80.1	-90.0	332.2	-464.8	-329.1	457.6	321.8	-339.5	82.7	-87.4	334.8	-462.2	-326.5	457.56	-464.84	0.88	OK
Story21	D41	A15.5	530	-3.42	0.00	-100.55	-25.78	1.21	-74.22	132.2	-3.7	458.3	317.2	-347.3	75.6	-85.3	337.5	-468.0	-327.0	460.8	319.8	-344.7	78.2	-82.7	340.1	-465.4	-324.4	460.05	-468.03	0.88	OK
Story20	D41	A15.5	530	-3.44	0.00	-105.24	-25.19	1.32	-72.54	135.5	2.3	460.0	315.6	-351.8	70.0	-79.9	342.0	-469.8	-322.4	463.6	316.2	-349.2	72.8	-77.3	344.6	-463.2	-320.8	462.59	-469.82	0.89	OK
Story19	D41	A15.5	530	-3.47	0.00	-109.95	-24.15	1.43	-69.55	138.1	10.2	459.0	306.0	-355.6	61.6	-71.5	345.7	-468.9	-315.9	461.6	308.6	-353.0	64.3	-68.9	348.3	-466.3	-313.3	461.61	-468.89	0.88	OK
Story18	D41	A15.5	530	-3.49	0.00	-114.69	-23.36	1.54	-67.29	141.1	17.1	460.3	300.6	-360.6	54.6	-64.6	350.6	-470.2	-310.9	462.6	302.5	-357.9	57.3	-62.0	352.2	-467.6	-308.2	462.90	-470.23	0.89	OK
Story17	D41	A15.5	530	-3.44	0.00	-119.06	-22.64	1.48	-65.22	143.9	23.7	461.6	296.2	-365.2	48.1	-58.0	355.3	-471.4	-306.0	464.2	298.8	-362.6	50.7	-55.4	357.9	-468.8	-303.4	464.17	-471.39	0.89	OK
Story16	D41	A15.5	530	-3.46	0.00	-123.51	-21.85	1.59	-62.95	146.6	30.3	462.5	290.9	-369.7	41.2	-51.1	359.9	-472.3	-300.8	465.1	292.5	-367.1	43.8	-48.5	362.5	-469.7	-298.2	465.38	-472.35	0.89	OK
Story15	D41	A15.5	530	-3.38	0.00	-127.28	-21.08	1.41	-60.76	148.6	36.6	463.0	285.6	-373.7	34.5	-44.2	364.1	-472.7	-295.2	465.6	288.1	-371.2	37.1	-41.6	366.6	-470.1	-292.7	465.56	-472.66	0.89	OK
Story14	D41	A15.5	530	-3.40	0.00	-131.03	-20.25	1.51	-58.37	150.7	42.8	463.4	279.9	-378.0	27.5	-37.2	368.2	-473.1	-289.6	466.0	282.5	-375.4	30.1	-34.7	370.8	-470.5	-287.1	465.98	-473.12	0.89	OK
Story13	D41	A15.5	530	-3.43	0.00	-134.71	-19.24	1.60	-56.47	152.3	49.5	462.7	272.7	-381.9	19.3	-29.1	372.1	-472.5	-282.5	465.3	275.3	-379.3	21.9	-26.5	374.7	-469.9	-279.9	465.28	-472.47	0.89	OK
Story12	D41	A15.5	530	-3.45	0.00	-138.33	-18.17	1.69	-54.28	153.7	55.7	459.2	267.5	-385.9	11.8	-21.0	375.8	-471.8	-275.9	464.6	269.2	-383.3	14.0	-18.9	377.7	-469.2	-283.8	465.18	-472.81	0.88	OK
Story11	D41	A15.5	530	-3.40	0.00	-141.58	-15.17	1.63	-43.77	151.7	69.9	446.6	239.5	-384.5	-9.9	0.1	374.8	-454.3	-249.2	449.2	242.1	-382.0	-7.3	2.7	377.4	-453.8	-246.6	449.20	-454.35	0.86	OK
Story10	D41	A15.5	530	-3.43	0.00	-144.84	-10.10	1.68	-29.17	148.1	90.5	416.7	194.8	-378.2	-43.7	-33.9	368.4	-426.5	-204.6	449.3	197.4	-375.6	-41.1	36.5	371.0	-423.9	-202.0	449.30	-426.50	0.80	OK
Story9	D41	A15.5	530	-3.45	0.00	-148.13	-8.65	1.68	-24.97	146.5	98.5	413.6	183.6	-382.0	-55.1	-45.2	372.1	-423.5	-193.5	445.3	186.2	-379.4	-52.5	47.9	374.7	-420.9	-190.8	446.25	-423.50	0.80	OK
Story8	D41	A15.5	530	-3.47	0.00	-151.30	-6.92	1.66	-21.30	143.9	103.6	416.9	170.1	-383.3	-61.4	-51.5	378.3	-426.9	-180.1	449.4	187.8	-385.6	-58.8	54.1	381.2	-424.2	-187.4	449.18	-424.20	0.80	OK
Story7	D41	A15.5	530	-3.42	0.00	-153.73	-7.43	1.53	-17.48	149.4	108.0	419.9	167.9	-389.9	-67.2	-57.4	384.1	-429.7	-166.7	452.5	189.5	-391.3	-64.6	60.0	386.7	-427.1	-184.1	422.53	-429.72	0.81	OK
Story6	D41	A15.5	530	-3.45	0.00	-156.74	-6.94	1.52	-15.06	150.4	111.5	423.2	174.4	-399.4	-73.2	-62.5	389.6	-433.0	-154.3	458.8	177.1	-396.8	-69.7	65.1	392.2	-430.4	-181.7	425.79	-433.03	0.82	OK
Story5	D41	A15.5	530	-3.47	0.00	-156.91	-4.46	1.53	-11.88	150.6	116.0	425.2	177.7	-401.8	-77.0	-67.1	393.9	-435.2	-141.6	457.9	174.3	-401.1	-74.4	69.7	396.5	-432.5	-179.0	427.87	-435.15	0.82	OK
Story4	D41	A15.5	530	-3.49	0.00	-156.02	-3.96	1.54	-9.25	149.4	121.2	427.7	181.5	-403.3	-80.3	-71.0	397.1	-437.2	-127.3	459.1	169.9	-405.0	-77.7	73.0	396.8	-429.6	-174.6	429.47	-435.20	0.82	OK
Story3	D41	A15.5	530	-3.44	0.00	-150.87	-5.48	1.45	-15.88	143.5	112.3	408.8	159.9	-391.8	-80.3	-70.4	382.0	-418.7	-160.8	441.5	162.5	-389.2	-77.7	73.0	384.6	-416.1	-167.2	411.46	-418.69	0.79	OK
Story2	D41	A15.5	530	-3.47	0.00	-137.49	-4.93	1.48	-14.30	133.5	102.1	373.9	145.6	-399.5	-74.4	-64.5	349.6	-383.8	-155.5	376.6	148.2	-356.9	-71.8	67.2	352.2	-381.2	-152.9	376.56	-383.84	0.72	OK
Story1	D41	A15.5	530	-3.16	0.00	-92.81	-3.64	1.44	-10.56	88.5	66.5	257.0	1																		

Story	ETABS #	Section	Capacity	Dead	Live	WindX	WindMTX	WindFY	WindMTY	Maximum Axial Loads													Status								
										Tension	Compression	DCR																			
Story0	D6	A7	239	-5.97	0.00	-4.11	9.15	0.01	-36.30	13.8	-33.6	140.5	104.8	-112.3	29.0	-46.1	95.2	-157.5	-121.9	145.0	109.3	-107.7	33.5	41.5	99.7	-153.0	-117.3	144.98	-157.52	0.66	OK
Story9	D6	A7	239	-5.98	0.00	-4.11	9.15	0.01	-36.30	13.8	-33.6	140.5	104.8	-112.3	29.0	-46.1	95.2	-157.5	-121.9	145.0	109.3	-107.7	33.5	41.5	99.7	-153.0	-117.3	144.98	-157.52	0.66	OK
Story10	D6	A7	239	-4.00	0.00	-12.67	6.80	0.07	-28.16	22.6	-28.2	184.5	122.7	-153.3	21.4	-38.5	104.2	-148.3	-127.7	155.7	115.2	-116.8	33.4	-41.5	108.7	-163.8	-123.2	155.73	-168.29	0.70	OK
Story7	D6	A8	274	-4.45	0.00	-16.14	-11.52	0.23	-33.11	28.4	-31.7	202.9	140.1	-164.8	29.8	-48.2	146.4	-221.3	-158.5	207.8	145.0	-159.9	34.7	-43.3	151.3	-216.4	-153.6	207.75	-221.29	0.81	OK
Story36	D6	A8	274	-4.46	0.00	-16.14	-11.93	0.54	-34.29	32.9	-29.8	218.5	147.2	-179.0	27.9	-46.4	160.5	-237.0	-165.6	222.4	152.0	-174.1	32.8	-41.5	165.4	-232.1	-160.7	223.44	-237.01	0.87	OK
Story35	D6	A8	274	-4.49	0.00	-22.72	-12.13	1.04	-34.85	36.9	-27.7	226.9	150.2	-187.1	26.0	-44.5	168.5	-245.5	-168.7	231.9	155.1	-182.2	30.9	-39.6	173.5	-249.6	-163.8	231.87	-245.50	0.90	OK
Story34	D6	A10	342	-7.37	0.00	-27.57	-15.80	1.90	-43.98	45.1	-36.9	256.4	181.5	-203.6	43.5	-44.4	182.5	-277.5	-202.6	262.0	187.1	-198.0	49.1	-59.0	188.1	-277.9	-197.0	261.96	-277.47	0.81	OK
Story33	D6	A10	342	-7.34	0.00	-30.84	-15.59	2.46	-44.80	49.7	-35.4	265.1	186.5	-210.7	43.8	-44.7	189.7	-286.1	-207.5	270.7	192.1	-205.2	49.3	-59.2	195.3	-280.5	-201.9	270.69	-286.11	0.84	OK
Story32	D6	A10	342	-7.42	0.00	-34.77	-15.80	3.23	-45.42	54.2	-33.4	270.8	190.4	-215.1	44.6	-45.8	193.9	-292.0	-211.6	276.4	196.0	-209.5	50.2	-60.2	199.5	-286.4	-206.0	276.41	-292.00	0.85	OK
Story31	D6	A10	342	-7.59	0.00	-37.56	-15.75	3.71	-45.26	57.1	-31.1	272.6	190.8	-218.9	44.0	-45.1	195.8	-293.7	-211.9	278.2	196.4	-208.1	49.6	-59.5	201.4	-288.1	-206.3	278.15	-293.67	0.86	OK
Story30	D6	A13.5	462	-8.99	0.00	-47.70	-21.10	5.87	-60.41	75.8	-44.1	342.3	250.2	-264.8	68.1	-58.2	239.1	-368.0	-275.9	349.1	257.0	-258.0	74.9	-86.9	245.9	-363.2	-269.1	349.13	-368.07	0.80	OK
Story29	D6	A13.5	462	-9.08	0.00	-50.80	-21.20	6.88	-60.95	79.6	-42.6	343.3	251.8	-265.2	69.2	-55.2	239.2	-369.3	-277.7	350.2	258.7	-258.1	76.1	-88.3	246.1	-362.4	-270.8	350.21	-369.28	0.80	OK
Story28	D6	A13.5	462	-9.29	0.00	-55.11	-21.17	8.26	-60.88	84.5	-40.1	348.7	254.0	-270.6	68.3	-54.8	244.0	-375.2	-280.6	355.7	261.1	-263.5	75.3	-87.8	251.1	-368.2	-273.6	355.71	-375.23	0.81	OK
Story27	D6	A13.5	462	-9.40	0.00	-58.17	-20.67	9.35	-61.45	89.2	-36.8	350.4	251.7	-271.5	64.2	-51.1	247.6	-377.3	-278.6	357.6	258.8	-267.3	71.3	-84.0	254.7	-370.2	-271.4	357.56	-377.30	0.82	OK
Story26	D6	A13.5	462	-9.65	0.00	-61.86	-20.49	10.90	-58.96	91.5	-34.4	349.1	251.1	-273.8	64.2	-51.8	246.2	-376.7	-275.7	356.4	258.4	-266.5	71.5	-84.5	253.6	-369.4	-271.3	356.41	-376.69	0.82	OK
Story25	D6	A15.5	530	-10.51	0.00	-68.28	-23.25	13.02	-66.90	103.1	-40.9	380.8	280.6	-294.2	78.1	-108.2	264.2	-410.9	-310.7	388.8	288.6	-286.3	86.1	-100.2	272.2	-402.9	-302.7	388.80	-410.88	0.78	OK
Story24	D6	A15.5	530	-10.49	0.00	-71.02	-22.97	13.93	-66.09	105.9	-38.3	379.2	278.4	-293.7	76.6	-106.6	263.7	-409.2	-308.4	387.1	286.4	-285.7	84.5	-98.6	271.6	-401.2	-300.5	387.14	-409.17	0.77	OK
Story23	D6	A15.5	530	-10.07	0.00	-74.79	-22.48	13.49	-64.71	108.5	-32.4	378.3	274.4	-295.6	71.9	-100.7	268.8	-408.1	-303.2	386.9	282.0	-287.9	79.5	-93.1	274.4	-400.4	-295.5	386.94	-408.08	0.77	OK
Story22	D6	A15.5	530	-9.70	0.00	-78.81	-22.13	13.17	-63.69	111.6	-26.9	380.8	271.8	-298.2	68.1	-95.8	270.5	-408.5	-299.6	388.2	279.2	-290.9	75.5	-88.5	277.9	-401.2	-292.2	388.18	-408.54	0.77	OK
Story21	D6	A15.5	530	-9.10	0.00	-82.48	-21.82	11.97	-62.81	113.8	-20.9	383.0	269.4	-301.1	64.1	-90.1	275.1	-409.0	-295.4	389.9	276.3	-294.2	71.0	-83.2	282.0	-402.1	-288.5	389.88	-408.99	0.77	OK
Story20	D6	A15.5	530	-8.60	0.00	-86.20	-21.34	10.86	-61.44	115.8	-14.4	384.0	265.6	-303.7	59.3	-83.9	279.1	-408.5	-290.1	390.5	272.1	-297.2	65.8	-77.3	285.6	-402.0	-283.6	390.47	-408.52	0.77	OK
Story19	D6	A15.5	530	-8.09	0.00	-89.97	-20.43	9.65	-58.85	117.1	-8.3	382.5	258.3	-305.7	51.8	-74.9	282.6	-405.7	-281.4	388.7	264.4	-299.6	58.0	-68.8	288.7	-399.5	-275.3	388.66	-405.66	0.77	OK
Story18	D6	A15.5	530	-7.58	0.00	-93.80	-19.81	8.31	-57.06	118.7	0.9	383.7	253.8	-308.9	46.0	-67.7	287.5	-405.4	-275.5	389.5	259.6	-303.2	51.8	-61.9	293.0	-399.6	-269.7	389.47	-405.39	0.76	OK
Story17	D6	A15.5	530	-7.12	0.00	-97.46	-19.25	7.09	-55.47	120.4	7.7	385.3	250.2	-311.1	41.1	-61.2	291.9	-405.7	-270.5	390.7	256.6	-306.3	46.3	-55.8	297.3	-400.3	-265.1	390.70	-405.66	0.77	OK
Story16	D6	A15.5	530	-6.72	0.00	-101.25	-18.65	5.85	-53.75	122.0	14.7	386.8	246.3	-315.7	35.5	-54.7	296.5	-406.0	-265.5	391.9	251.3	-310.6	40.6	-49.6	301.6	-400.9	-260.4	391.89	-406.00	0.77	OK
Story15	D6	A15.5	530	-6.42	0.00	-105.01	-18.03	4.76	-51.95	124.4	20.4	388.6	242.5	-320.1	29.9	-48.8	301.2	-407.6	-261.5	393.6	247.6	-315.1	34.9	-43.8	306.2	-402.5	-254.4	393.64	-407.55	0.77	OK
Story14	D6	A15.5	530	-6.59	0.00	-108.88	-17.35	3.77	-50.03	126.8	26.3	390.6	238.5	-325.1	23.8	-42.7	306.2	-409.4	-257.4	395.6	243.5	-320.1	28.8	-37.7	311.2	-404.4	-252.4	395.60	-409.44	0.77	OK
Story13	D6	A15.5	530	-6.54	0.00	-112.79	-16.53	2.89	-47.66	128.9	32.8	391.8	233.2	-329.9	16.6	-35.3	311.3	-410.5	-251.9	396.8	238.1	-325.0	21.6	-30.4	316.2	-405.5	-246.9	396.76	-410.49	0.77	OK
Story12	D6	A15.5	530	-6.47	0.00	-116.75	-15.28	2.49	-44.08	130.2	40.9	390.4	224.0	-334.1	6.7	-25.2	315.6	-409.9	-242.5	395.3	229.0	-329.2	11.6	-20.3	320.5	-404.0	-237.6	395.31	-408.89	0.77	OK
Story11	D6	A15.5	530	-6.26	0.00	-120.48	-12.87	1.99	-40.35	129.4	53.0	389.6	204.1	-335.2	-10.6	-7.6	317.0	-398.7	-222.3	385.4	209.0	-330.4	5.8	-2.8	321.9	-392.9	-217.5	385.38	-398.74	0.75	OK
Story10	D6	A15.5	530	-6.31	0.00	-124.41	-8.02	1.16	-32.16	124.7	73.6	353.5	161.7	-330.7	-43.6	-25.5	312.7	-371.6	-179.7	358.3	166.5	-325.9	-38.8	30.3	317.5	-366.8	-175.0	358.31	-371.56	0.70	OK
Story9	D6	A15.5	530	-5.83	0.00	-127.81	-6.82	0.84	-19.69	124.8	82.7	353.1	152.8	-335.0	-53.6	-36.9	318.4	-369.8	-169.5	357.5	157.3	-330.6	-49.2	41.4	322.8	-365.4	-165.1	357.55	-369.78	0.70	OK
Story8	D6	A15.5	530	-5.25	0.00	-131.29	-4.42	2.22	-18.56	126.4	88.9	359.6	152.0	-342.3	-58.6	-43.3	327.0	-374.9	-167.3	362.6	156.0	-338.2	-54.5	47.4	331.0	-370.8	-163.2	362.63	-374.86	0.71	OK
Story7	D6	A15.5	530	-5.26	0.00	-134.96	-4.00	2.77	-17.26	129.1	93.7	364.5	151.1	-350.9	-64.1	-49.1	335.9	-381.5	-166.1	370.4	155.1	-344.8	-60.3	53.1	339.8	-377.5	-162.1	370.44	-381.49	0.72	OK
Story6	D6	A15.5	530	-5.19	0.00	-138.30	-5.66	2.40	-16.38	131.8	98.0	374.0	150.9	-359.8	-69.2	-54.4	340.6	-388.8	-165.8	377.9	154.9	-355.9	-65.3	58.3	348.9	-384.8	-161.8	377.89	-388.78	0.73	OK
Story5	D6	A15.5	530	-4.67	0.00	-140.41	-5.37	1.34	-15.54	132.6	102.2	380.2	150.8	-366.2	-73.1	-59.8	352.9	-393.6	-164.2	383.8	154.4	-362.7	-69.6	63.3	356.4	-390.0	-160.6	383.76	-393.57	0.74	OK
Story4	D6	A15.5	530	-4.15	0.00	-140.67	-5.06	0.30	-14.65	131.9	105.0	382.1	149.4	-368.3	-75.7	-63.9	356.5	-394.0	-161.3	385.3	152.6	-365.2	-72.6	67.0	359.6	-390.8	-158.1	385.28	-393.98	0.74	OK
Story3	D6	A15.5	530	-3.62	0.00	-136.87	-4.75	-0.62	-13.77	127.6	103.9	373.9	145.1	-362.2	-75.1	-64.7	349.6	-384.3	-155.5	378.7	147.9	-357.4	-72.4	67.5	352.6	-381.5	-152.7	376.68	-384.30	0.72	OK
Story2	D6	A15.5	530	-3.13	0.00	-125.09	-4.38	-1.52	-12.70	116.0	95.9	344.9	134.2	-331.5	-68.7	-59.7	322.6	-353.9	-143.2	347.3	136.6	-329.1	-66.3	62.1	324.9	-357.5	-140.8	347.28	-353.86	0.67	OK
Story1	D6	A15.5	530	-2.72	0.00	-83.92	-3.26	-1.07	-9.46	77.8	62.7	236.8</																			



SHEET NO. _____

PROJECT NO. 087237.10

DATE 1/23/09

CLIENT Pacific Earthquake Engineering Research Center

BY AD

SUBJECT Infilled Column Strength & Stiffness Evaluation

CHECKED BY _____

Fy = 50 ksi
 fc = 10 ksi
 wc = 150 lb/ft3
 C2 = 0.85
 ws = 490 lb/ft3

Ec = 5809.47502 ksi

1	2	3	4	5	6	7	8	9	10	11	12	13	14	15	16	17	18	19	20	21	22	23
Col Type	B	D	Reinforcing	Quantity Each Direction	Pl. Thk	Ar	t-wall	Ac	As	As/A-total	b/t	Status	C3	Ic	Eieff	φc Po	φt Po	Wt/Ft	Ibox	I mult	Aeff	Amult
Box18	18	18				0	1.5	225	99	30.6%	10.0	OK	0.9	4.22E+03	1.53E+08	5146.9	4455	571.3	4.53E+03	1.17	4.18E+06	1.46
Box21	21	21				0	1.5	324	117	26.5%	12.0	OK	0.9	8.75E+03	2.62E+08	6453.0	5265	735.6	7.46E+03	1.21	5.29E+06	1.55
Box24	24	24				0	2.0	400	176	30.6%	10.0	OK	0.9	1.33E+04	4.85E+08	9150.0	7920	1015.6	1.43E+04	1.17	7.43E+06	1.46
Box27	27	27				0	2.0	529	200	27.4%	11.5	OK	0.9	2.33E+04	7.30E+08	10872.4	9000	1231.6	2.10E+04	1.20	8.87E+06	1.53
Box30	30	30				0	2.5	625	275	30.6%	10.0	OK	0.9	3.26E+04	1.18E+09	14296.9	12375	1586.8	3.49E+04	1.17	1.16E+07	1.46
Box33	33	33				0	2.5	784	305	28.0%	11.2	OK	0.9	5.12E+04	1.65E+09	16435.5	13725	1854.5	4.76E+04	1.19	1.34E+07	1.51
Box36	36	36				0	2.5	961	335	25.8%	12.4	OK	0.9	7.70E+04	2.23E+09	18688.9	15075	2141.0	6.30E+04	1.22	1.53E+07	1.57
Box39	39	39				0	3.0	1089	432	28.4%	11.0	OK	0.9	9.88E+04	3.24E+09	23142.4	19440	2604.4	9.40E+04	1.19	1.89E+07	1.50
Box42	42	42				0	3.0	1296	468	26.5%	12.0	OK	0.9	1.40E+05	4.19E+09	25812.0	21060	2942.5	1.19E+05	1.21	2.11E+07	1.55
Box45	45	45				0	3.0	1521	504	24.9%	13.0	OK	0.9	1.93E+05	5.33E+09	28596.4	22680	3299.4	1.49E+05	1.23	2.35E+07	1.60
Box48	48	48				0	3.0	1764	540	23.4%	14.0	OK	0.9	2.59E+05	6.66E+09	31495.5	24300	3675.0	1.83E+05	1.26	2.59E+07	1.65
Box51	51	51				0	3.0	2025	576	22.1%	15.0	OK	0.9	3.42E+05	8.23E+09	34509.4	25920	4069.4	2.22E+05	1.28	2.85E+07	1.70
Box54	54	54				0	3.0	2304	612	21.0%	16.0	OK	0.9	4.42E+05	1.00E+10	37638.0	27540	4482.5	2.66E+05	1.30	3.11E+07	1.75
Box57	57	57				0	3.0	2601	648	19.9%	17.0	OK	0.9	5.64E+05	1.21E+10	40881.4	29160	4914.4	3.16E+05	1.32	3.39E+07	1.80
Box60	60	60				0	3.0	2916	684	19.0%	18.0	OK	0.9	7.09E+05	1.45E+10	44239.5	30780	5365.0	3.71E+05	1.34	3.68E+07	1.85

S_{DS} = 1.145
F_y Column = 50 ksi

Floor	Height	Trib Area	Cum Area	LL Red Fact	Dead Load	Reducible	Unreducible	Dead Load	Live Load	Brace @ Left					Brace @ Right					Net Brace C	Net Brace T	Pu-Comp	Pu-Tension	Col Type	φc Po	φt Po	Comp DCR	Ten DCR	Status		
										ETABS Br #	Bay Length	Brace Type	Brace Comprsn	Brace Tension	Brace C Vert Comp	Brace T Vert Cor	ETABS Br #	Bay Length	Brace Type											Br. Comprsn	Brace Tension
						Live Load	Live Load																								
Story40	13.5	400	670		95			38	0.0												0.00	0.00	54.3	25.5							
Story39	13.5	400	400	0.8	97	40		76.8	12.8												0.00	0.00	116.1	51.5							
Story38	13.5	400	800	0.48	97	40		115.6	20.5												0.00	0.00	175.4	77.6							
Story37	13.5	400	1200	0.4	97	40		154.4	26.9												0.00	0.00	234.1	103.6							
Story36	13.5	400	1600	0.4	97	40		193.2	33.3												0.00	0.00	292.7	129.6							
Story35	13.5	400	2000	0.4	97	40		232	39.7												0.00	0.00	351.4	155.7							
Story34	13.5	400	2400	0.4	97	40		270.8	46.1												0.00	0.00	410.0	181.7							
Story33	13.5	400	2800	0.4	97	40		309.6	52.5												0.00	0.00	468.7	207.7							
Story32	13.5	400	3200	0.4	102	40		350.4	58.9												0.00	0.00	530.2	235.1							
Story31	13.5	400	3600	0.4	102	40		391.2	65.3												0.00	0.00	591.7	262.5							
Story30	13.5	400	4000	0.4	102	40		432	71.7												0.00	0.00	653.2	289.9							
Story29	13.5	400	4400	0.4	102	40		472.8	78.1												0.00	0.00	714.7	317.2							
Story28	13.5	400	4800	0.4	102	40		513.6	84.5												0.00	0.00	776.2	344.6							
Story27	13.5	400	5200	0.4	107	40		556.4	90.9												0.00	0.00	840.5	373.3							
Story26	13.5	400	5600	0.4	107	40		599.2	97.3												0.00	0.00	904.9	402.1							
Story25	13.5	400	6000	0.4	107	40		642	103.7												0.00	0.00	969.3	430.8							
Story24	13.5	400	6400	0.4	107	40		684.8	110.1												0.00	0.00	1033.6	459.5							
Story23	13.5	400	6800	0.4	112	40		729.6	116.5												0.00	0.00	1100.8	489.6							
Story22	13.5	400	7200	0.4	112	40		774.4	122.9												0.00	0.00	1168.1	519.6							
Story21	13.5	400	7600	0.4	112	40		819.2	129.3												0.00	0.00	1235.3	549.7							
Story20	13.5	400	8000	0.4	112	40		864	135.7												0.00	0.00	1302.5	579.7							
Story19	13.5	400	8400	0.4	117	40		910.8	142.1												0.00	0.00	1372.6	611.1							
Story18	13.5	400	8800	0.4	117	40		957.6	148.5												0.00	0.00	1442.7	642.5							
Story17	13.5	400	9200	0.4	117	40		1004.4	154.9												0.00	0.00	1512.7	674.0							
Story16	13.5	400	9600	0.4	117	40		1051.2	161.3												0.00	0.00	1582.8	705.4							
Story15	13.5	400	10000	0.4	117	40		1098	167.7												0.00	0.00	1652.9	736.8							
Story14	13.5	400	10400	0.4	127	40		1148.8	174.1												0.00	0.00	1728.7	770.8							
Story13	13.5	400	10800	0.4	127	40		1199.6	180.5												0.00	0.00	1804.5	804.9							
Story12	13.5	400	11200	0.4	127	40		1250.4	186.9												0.00	0.00	1880.3	839.0							
Story11	13.5	400	11600	0.4	127	40		1301.2	193.3												0.00	0.00	1956.1	873.1							
Story10	13.5	400	12000	0.4	127	40		1352	199.7					D25	27	A25	1436.9	-1306.3	1016.02	-923.66	1016.02	-923.66	3047.9	-16.5	Box21	6453.0	5265	0.472	0.003	OK	
Story9	13.5	400	12400	0.4	140	40		1408	206.1					D25	27	A25	1436.9	-1306.3	1016.02	-923.66	1016.02	-923.66	4147.1	-902.5	Box21	6453.0	5265	0.643	0.171	OK	
Story8	13.5	400	12800	0.4	140	40		1464	212.5					D25	27	A25	1436.9	-1306.3	1016.02	-923.66	1016.02	-923.66	5246.4	-1788.6	Box21	6453.0	5265	0.813	0.340	OK	
Story7	13.5	400	13200	0.4	140	40		1520	218.9					D25	27	A27	1551.8	-1410.8	1097.31	-997.55	1097.31	-997.55	6426.9	-2748.6	Box24	9150.0	7920	0.702	0.347	OK	
Story6	13.5	400	13600	0.4	140	40		1576	225.3					D25	27	A27	1551.8	-1410.8	1097.31	-997.55	1097.31	-997.55	7607.4	-3708.6	Box24	9150.0	7920	0.831	0.468	OK	
Story5	13.5	400	14000	0.4	140	40		1632	231.7					D25	27	A27	1551.8	-1410.8	1097.31	-997.55	1097.31	-997.55	8788.0	-4668.6	Box27	10872.4	9000	0.808	0.519	OK	
Story4	13.5	400	14400	0.4	142	40		1688.8	238.1					D25	27	A27	1551.8	-1410.8	1097.31	-997.55	1097.31	-997.55	9969.6	-5628.0	Box27	10872.4	9000	0.917	0.625	OK	
Story3	13.5	400	14800	0.4	142	40		1745.6	244.5					D25	27	A27	1551.8	-1410.8	1097.31	-997.55	1097.31	-997.55	11151.3	-6587.4	Box30	14296.9	12375	0.780	0.532	OK	
Story2	13.5	400	15200	0.4	142	40		1802.4	250.9					D25	27	A27	1551.8	-1410.8	1097.31	-997.55	1097.31	-997.55	12333.0	-7546.9	Box30	14296.9	12375	0.863	0.610	OK	
Story1	18	400	15600	0.4	150	40		1862.4	257.3					D25	27	A27	1551.8	-1410.8	1241.46	-1128.60	1241.46	-1128.60	13663.4	-8635.2	Box36	18688.9	15075	0.731	0.573	OK	
Ground	12	1168.8		1	515.5	100		2464.9164	374.2					D25	27	A18.5	1063.3	-966.6	706.41	-642.19	706.41	-642.19	15289.2	-8873.1	Box36	18688.9	15075	0.818	0.589	OK	
B1	12	1168.8		1	85.5	40		2564.8488	420.9					D25	27	A18.5	1063.3	-966.6	706.41	-642.19	706.41	-642.19	16161.8	-9448.2	Box39	23142.4	19440	0.698	0.486	OK	
B2	12	1168.8		1	85.5	40		2664.7812	467.7					D25	27	A18.5	1063.3	-966.6	706.41	-642.19	706.41	-642.19	17034.4	-10023.4	Box39	23142.4	19440	0.736	0.516	OK	
B3	12	1168.8		1	85.5	40		2764.7136	514.4					D25	27	A18.5	1063.3	-966.6	706.41	-642.19	706.41	-642.19	17907.0	-10598.5	Box39	23142.4	19440	0.774	0.545	OK	

CLIENT Pacific Earthquake Engineering Research Center
 SUBJECT Col D/2 Strength Check for LA BRBF Bldg

S_{DS} = 1.145
 F_y Column = 50 ksi

Floor	Height	Trib Area	Cum Area	LL Red Fact	Dead Load	Reducible	Unreducible	Dead Load	Live Load	Brace @ Left					Brace @ Right					Net Brace C	Net Brace T	Pu-Comp	Pu-Tension	Col Type	φc Po	φt Po	Comp DCR	Ten DCR	Status				
										ETABS Br #	Bay Length	Brace Type	Brace Comprsn	Brace Tension	Brace C Vert Comp	Brace T Vert Cor	ETABS Br #	Bay Length	Brace Type											Br. Comprsn	Brace Tension	Brace C Vert Comp	Brace T Vert Comp
Story40	13.5	670	670		95			63.65	0.0							D21	27	A6	344.9	-313.5	243.85	-221.68	243.85	-221.68	334.8	-179.0	Box21	6453.0	5265	0.052	0.034	OK	
Story39	13.5	670	670	0.584	97	40		128.64	15.7							D21	27	A6	344.9	-313.5	243.85	-221.68	243.85	-221.68	679.3	-357.0	Box21	6453.0	5265	0.105	0.068	OK	
Story38	13.5	670	1340	0.4	97	40		193.63	26.4							D21	27	A6	344.9	-313.5	243.85	-221.68	243.85	-221.68	1021.4	-535.1	Box21	6453.0	5265	0.158	0.102	OK	
Story37	13.5	670	2010	0.4	97	40		258.62	37.1							D21	27	A6	344.9	-313.5	243.85	-221.68	243.85	-221.68	1363.5	-713.2	Box21	6453.0	5265	0.211	0.135	OK	
Story36	13.5	670	2680	0.4	97	40		323.61	47.8							D21	27	A6	344.9	-313.5	243.85	-221.68	243.85	-221.68	1705.6	-891.2	Box21	6453.0	5265	0.264	0.169	OK	
Story35	13.5	670	3350	0.4	97	40		388.6	58.5							D21	27	A9	517.3	-470.3	365.77	-332.52	365.77	-332.52	2169.6	-1180.2	Box21	6453.0	5265	0.336	0.224	OK	
Story34	13.5	670	4020	0.4	97	40		453.59	69.3							D21	27	A9	517.3	-470.3	365.77	-332.52	365.77	-332.52	2633.6	-1469.1	Box21	6453.0	5265	0.408	0.279	OK	
Story33	13.5	670	4690	0.4	97	40		518.58	80.0							D21	27	A9	517.3	-470.3	365.77	-332.52	365.77	-332.52	3097.6	-1758.0	Box21	6453.0	5265	0.480	0.334	OK	
Story32	13.5	670	5360	0.4	102	40		586.92	90.7							D21	27	A9	517.3	-470.3	365.77	-332.52	365.77	-332.52	3566.4	-2044.6	Box21	6453.0	5265	0.553	0.388	OK	
Story31	13.5	670	6030	0.4	102	40		655.26	101.4							D21	27	A9	517.3	-470.3	365.77	-332.52	365.77	-332.52	4035.1	-2331.3	Box21	6453.0	5265	0.625	0.443	OK	
Story30	13.5	670	6700	0.4	102	40		723.6	112.1							D21	27	A9	517.3	-470.3	365.77	-332.52	365.77	-332.52	4503.9	-2618.0	Box21	6453.0	5265	0.698	0.497	OK	
Story29	13.5	670	7370	0.4	102	40		791.94	122.9							D21	27	A9	517.3	-470.3	365.77	-332.52	365.77	-332.52	4972.7	-2904.6	Box21	6453.0	5265	0.771	0.552	OK	
Story28	13.5	670	8040	0.4	102	40		860.28	133.6							D21	27	A9	517.3	-470.3	365.77	-332.52	365.77	-332.52	5441.5	-3191.3	Box21	6453.0	5265	0.843	0.606	OK	
Story27	13.5	670	8710	0.4	107	40		931.97	144.3							D21	27	A15.5	890.9	-809.9	629.93	-572.67	629.93	-572.67	6179.2	-3715.8	Box24	9150.0	7920	0.675	0.469	OK	
Story26	13.5	670	9380	0.4	107	40		1003.66	155.0							D21	27	A15.5	890.9	-809.9	629.93	-572.67	629.93	-572.67	6917.0	-4240.4	Box24	9150.0	7920	0.756	0.535	OK	
Story25	13.5	670	10050	0.4	107	40		1075.35	165.7							D21	27	A15.5	890.9	-809.9	629.93	-572.67	629.93	-572.67	7654.7	-4765.0	Box24	9150.0	7920	0.837	0.602	OK	
Story24	13.5	670	10720	0.4	107	40		1147.04	176.5							D21	27	A15.5	890.9	-809.9	629.93	-572.67	629.93	-572.67	8392.5	-5289.5	Box24	9150.0	7920	0.917	0.668	OK	
Story23	13.5	670	11390	0.4	112	40		1222.08	187.2							D21	27	A18.5	1063.3	-966.6	751.86	-683.51	751.86	-683.51	9256.9	-5922.7	Box27	10872.4	9000	0.851	0.658	OK	
Story22	13.5	670	12060	0.4	112	40		1297.12	197.9							D21	27	A18.5	1063.3	-966.6	751.86	-683.51	751.86	-683.51	10121.4	-6555.8	Box27	10872.4	9000	0.931	0.728	OK	
Story21	13.5	670	12730	0.4	112	40		1372.16	208.6							D21	27	A18.5	1063.3	-966.6	751.86	-683.51	751.86	-683.51	10985.8	-7189.0	Box30	14296.9	12375	0.768	0.581	OK	
Story20	13.5	670	13400	0.4	112	40		1447.2	219.3							D21	27	A18.5	1063.3	-966.6	751.86	-683.51	751.86	-683.51	11850.3	-7822.2	Box30	14296.9	12375	0.829	0.632	OK	
Story19	13.5	670	14070	0.4	117	40		1525.59	230.1							D21	27	A25	1436.9	-1306.3	1016.02	-923.66	1016.02	-923.66	12983.7	-8693.2	Box33	16435.5	13725	0.790	0.633	OK	
Story18	13.5	670	14740	0.4	117	40		1603.98	240.8							D21	27	A25	1436.9	-1306.3	1016.02	-923.66	1016.02	-923.66	14117.1	-9564.3	Box33	16435.5	13725	0.859	0.697	OK	
Story17	13.5	670	15410	0.4	117	40		1682.37	251.5							D21	27	A25	1436.9	-1306.3	1016.02	-923.66	1016.02	-923.66	15250.5	-10435.3	Box36	18688.9	15075	0.816	0.692	OK	
Story16	13.5	670	16080	0.4	117	40		1760.76	262.2							D21	27	A25	1436.9	-1306.3	1016.02	-923.66	1016.02	-923.66	16383.9	-11306.4	Box36	18688.9	15075	0.877	0.750	OK	
Story15	13.5	670	16750	0.4	117	40		1839.15	272.9							D21	27	A25	1436.9	-1306.3	1016.02	-923.66	1016.02	-923.66	17517.3	-12177.4	Box39	23142.4	19440	0.757	0.626	OK	
Story14	13.5	670	17420	0.4	127	40		1924.24	283.7							D21	27	A25	1436.9	-1306.3	1016.02	-923.66	1016.02	-923.66	18660.3	-13044.0	Box39	23142.4	19440	0.806	0.671	OK	
Story13	13.5	670	18090	0.4	127	40		2009.33	294.4							D21	27	A25	1436.9	-1306.3	1016.02	-923.66	1016.02	-923.66	19803.2	-13910.6	Box39	23142.4	19440	0.856	0.716	OK	
Story12	13.5	670	18760	0.4	127	40		2094.42	305.1							D21	27	A25	1436.9	-1306.3	1016.02	-923.66	1016.02	-923.66	20946.2	-14777.1	Box39	23142.4	19440	0.905	0.760	OK	
Story11	13.5	670	19430	0.4	127	40		2179.51	315.8							D21	27	A25	1436.9	-1306.3	1016.02	-923.66	1016.02	-923.66	22089.2	-15643.7	Box42	25812.0	21060	0.856	0.743	OK	
Story10	13.5	670	20100	0.4	127	40		2264.6	326.5	D26	40.0	A25	1436.9	-1306.3	803.89	-730.81	D21	27	A15.5	890.9	-809.9	629.93	-572.67	231.22	-100.88	22447.4	-15687.5	Box42	25812.0	21060	0.870	0.745	OK
Story9	13.5	670	20770	0.4	140	40		2358.4	337.3	D26	40.0	A25	1436.9	-1306.3	803.89	-730.81	D21	27	A15.5	890.9	-809.9	629.93	-572.67	231.22	-100.88	22818.0	-15725.4	Box45	28596.4	22680	0.798	0.693	OK
Story8	13.5	670	21440	0.4	140	40		2452.2	348.0	D26	40.0	A25	1436.9	-1306.3	803.89	-730.81	D21	27	A15.5	890.9	-809.9	629.93	-572.67	231.22	-100.88	23188.6	-15763.4	Box45	28596.4	22680	0.811	0.695	OK
Story7	13.5	670	22110	0.4	140	40		2546	358.7	D26	40.0	A27	1551.8	-1410.8	868.20	-789.28	D21	27	A15.5	890.9	-809.9	629.93	-572.67	295.54	-159.34	23623.6	-15859.8	Box48	31495.5	24300	0.750	0.653	OK
Story6	13.5	670	22780	0.4	140	40		2639.8	369.4	D26	40.0	A27	1551.8	-1410.8	868.20	-789.28	D21	27	A15.5	890.9	-809.9	629.93	-572.67	295.54	-159.34	24058.5	-15956.2	Box48	31495.5	24300	0.764	0.657	OK
Story5	13.5	670	23450	0.4	140	40		2733.6	380.1	D26	40.0	A27	1551.8	-1410.8	868.20	-789.28	D21	27	A15.5	890.9	-809.9	629.93	-572.67	295.54	-159.34	24493.4	-16052.6	Box48	31495.5	24300	0.778	0.661	OK
Story4	13.5	670	24120	0.4	142	40		2828.74	390.9	D26	40.0	A27	1551.8	-1410.8	868.20</																		

S_{DS} = 1.145
F_y Beam = 50 ksi

Floor	Height (ft)	Beam Span (ft)	Brace Label	Brace Sec.	Comp Cap (kips)	Tens Cap (kips)	Brace Angle (radians)	Unb. Up F (kips)	Unb Moment (kip-ft)	Dead Load (psf)	Trib Width (ft)	Addl Dead Line (kips/ft)	Total Moment (kip-ft)	Beam Comp. (kips)	Collector	Beam	bf/2f	h/tw	Ca	Seismically Compact	φMn (kip-ft)	φPcr (kips)	Interaction	Comment
Story40	13.5	27	D21	A6	344.85	-313.5	0.7854	22.17	149.6	80	5	0.25	109.89	232.76	CT1	W14X53	6.11	30.9	0.332	Yes	310.6	417.1	0.872	OK
Story39	13.5	27	D21	A6	344.85	-313.5	0.7854	22.17	149.6	79.5	5	0.25	110.04	232.76	CT1	W14X53	6.11	30.9	0.332	Yes	310.6	417.1	0.873	OK
Story38	13.5	27	D21	A6	344.85	-313.5	0.7854	22.17	149.6	79.5	5	0.25	110.04	232.76	CT1	W14X53	6.11	30.9	0.332	Yes	310.6	417.1	0.873	OK
Story37	13.5	27	D21	A6	344.85	-313.5	0.7854	22.17	149.6	79.5	5	0.25	110.04	232.76	CT1	W14X53	6.11	30.9	0.332	Yes	310.6	417.1	0.873	OK
Story36	13.5	27	D21	A6	344.85	-313.5	0.7854	22.17	149.6	79.5	5	0.25	110.04	232.76	CT1	W14X53	6.11	30.9	0.332	Yes	310.6	417.1	0.873	OK
Story35	13.5	27	D21	A9	517.275	-470.25	0.7854	33.25	224.4	79.5	5	0.25	184.86	349.14	CT2	W14X68	6.97	27.5	0.388	Yes	442.3	655.4	0.904	OK
Story34	13.5	27	D21	A9	517.275	-470.25	0.7854	33.25	224.4	79.5	5	0.25	184.86	349.14	CT2	W14X68	6.97	27.5	0.388	Yes	442.3	655.4	0.904	OK
Story33	13.5	27	D21	A9	517.275	-470.25	0.7854	33.25	224.4	79.5	5	0.25	184.86	349.14	CT2	W14X68	6.97	27.5	0.388	Yes	442.3	655.4	0.904	OK
Story32	13.5	27	D21	A9	517.275	-470.25	0.7854	33.25	224.4	79.5	5	0.25	184.86	349.14	CT2	W14X68	6.97	27.5	0.388	Yes	442.3	655.4	0.904	OK
Story31	13.5	27	D21	A9	517.275	-470.25	0.7854	33.25	224.4	79.5	5	0.25	184.86	349.14	CT2	W14X68	6.97	27.5	0.388	Yes	442.3	655.4	0.904	OK
Story30	13.5	27	D21	A9	517.275	-470.25	0.7854	33.25	224.4	79.5	5	0.25	184.86	349.14	CT2	W14X68	6.97	27.5	0.388	Yes	442.3	655.4	0.904	OK
Story29	13.5	27	D21	A9	517.275	-470.25	0.7854	33.25	224.4	79.5	5	0.25	184.86	349.14	CT2	W14X68	6.97	27.5	0.388	Yes	442.3	655.4	0.904	OK
Story28	13.5	27	D21	A9	517.275	-470.25	0.7854	33.25	224.4	79.5	5	0.25	184.86	349.14	CT2	W14X68	6.97	27.5	0.388	Yes	442.3	655.4	0.904	OK
Story27	13.5	27	D21	A15.5	890.8625	-809.875	0.7854	57.27	386.6	79.5	5	0.25	346.96	601.30	CT3	W16X100	5.29	23.2	0.450	Yes	778.7	983.2	1.008	Say OK
Story26	13.5	27	D21	A15.5	890.8625	-809.875	0.7854	57.27	386.6	79.5	5	0.25	346.96	601.30	CT3	W16X100	5.29	23.2	0.450	Yes	778.7	983.2	1.008	Say OK
Story25	13.5	27	D21	A15.5	890.8625	-809.875	0.7854	57.27	386.6	79.5	5	0.25	346.96	601.30	CT3	W16X100	5.29	23.2	0.450	Yes	778.7	983.2	1.008	Say OK
Story24	13.5	27	D21	A15.5	890.8625	-809.875	0.7854	57.27	386.6	79.5	5	0.25	346.96	601.30	CT3	W16X100	5.29	23.2	0.450	Yes	778.7	983.2	1.008	Say OK
Story23	13.5	27	D21	A18.5	1063.2875	-966.625	0.7854	68.35	461.4	79.5	5	0.25	421.78	717.68	CT4	W14X132	7.15	17.7	0.411	Yes	973.4	1524.4	0.856	OK
Story22	13.5	27	D21	A18.5	1063.2875	-966.625	0.7854	68.35	461.4	79.5	5	0.25	421.78	717.68	CT4	W14X132	7.15	17.7	0.411	Yes	973.4	1524.4	0.856	OK
Story21	13.5	27	D21	A18.5	1063.2875	-966.625	0.7854	68.35	461.4	79.5	5	0.25	421.78	717.68	CT4	W14X132	7.15	17.7	0.411	Yes	973.4	1524.4	0.856	OK
Story20	13.5	27	D21	A18.5	1063.2875	-966.625	0.7854	68.35	461.4	79.5	5	0.25	421.78	717.68	CT4	W14X132	7.15	17.7	0.411	Yes	973.4	1524.4	0.856	OK
Story19	13.5	27	D21	A25	1436.875	-1306.25	0.7854	92.37	623.5	79.5	5	0.25	583.88	969.84	CT5	W14X159	6.54	15.3	0.461	Yes	1195.8	1864.0	0.954	OK
Story18	13.5	27	D21	A25	1436.875	-1306.25	0.7854	92.37	623.5	79.5	5	0.25	583.88	969.84	CT5	W14X159	6.54	15.3	0.461	Yes	1195.8	1864.0	0.954	OK
Story17	13.5	27	D21	A25	1436.875	-1306.25	0.7854	92.37	623.5	79.5	5	0.25	583.88	969.84	CT5	W14X159	6.54	15.3	0.461	Yes	1195.8	1864.0	0.954	OK
Story16	13.5	27	D21	A25	1436.875	-1306.25	0.7854	92.37	623.5	79.5	5	0.25	583.88	969.84	CT5	W14X159	6.54	15.3	0.461	Yes	1195.8	1864.0	0.954	OK
Story15	13.5	27	D21	A25	1436.875	-1306.25	0.7854	92.37	623.5	79.5	5	0.25	583.88	969.84	CT5	W14X159	6.54	15.3	0.461	Yes	1195.8	1864.0	0.954	OK
Story14	13.5	27	D21	A25	1436.875	-1306.25	0.7854	92.37	623.5	79.5	5	0.25	583.88	969.84	CT5	W14X159	6.54	15.3	0.461	Yes	1195.8	1864.0	0.954	OK
Story13	13.5	27	D21	A25	1436.875	-1306.25	0.7854	92.37	623.5	79.5	5	0.25	583.88	969.84	CT5	W14X159	6.54	15.3	0.461	Yes	1195.8	1864.0	0.954	OK
Story12	13.5	27	D21	A25	1436.875	-1306.25	0.7854	92.37	623.5	79.5	5	0.25	583.88	969.84	CT5	W14X159	6.54	15.3	0.461	Yes	1195.8	1864.0	0.954	OK
Story11	13.5	27	D21	A25	1436.875	-1306.25	0.7854	92.37	623.5	79.5	5	0.25	583.88	969.84	CT5	W14X159	6.54	15.3	0.461	Yes	1195.8	1864.0	0.954	OK
Story10	13.5	27	D21	A15.5	890.8625	-809.875	0.7854	57.27	386.6	79.5	5	0.25	346.96	601.30	CT3	W16X100	5.29	23.2	0.450	Yes	778.7	983.2	1.008	Say OK
Story9	13.5	27	D21	A15.5	890.8625	-809.875	0.7854	57.27	386.6	79.5	5	0.25	346.96	601.30	CT3	W16X100	5.29	23.2	0.450	Yes	778.7	983.2	1.008	Say OK
Story8	13.5	27	D21	A15.5	890.8625	-809.875	0.7854	57.27	386.6	79.5	5	0.25	346.96	601.30	CT3	W16X100	5.29	23.2	0.450	Yes	778.7	983.2	1.008	Say OK
Story7	13.5	27	D21	A15.5	890.8625	-809.875	0.7854	57.27	386.6	79.5	5	0.25	346.96	601.30	CT3	W16X100	5.29	23.2	0.450	Yes	778.7	983.2	1.008	Say OK
Story6	13.5	27	D21	A15.5	890.8625	-809.875	0.7854	57.27	386.6	79.5	5	0.25	346.96	601.30	CT3	W16X100	5.29	23.2	0.450	Yes	778.7	983.2	1.008	Say OK
Story5	13.5	27	D21	A15.5	890.8625	-809.875	0.7854	57.27	386.6	79.5	5	0.25	346.96	601.30	CT3	W16X100	5.29	23.2	0.450	Yes	778.7	983.2	1.008	Say OK
Story4	13.5	27	D21	A15.5	890.8625	-809.875	0.7854	57.27	386.6	79.5	5	0.25	346.96	601.30	CT3	W16X100	5.29	23.2	0.450	Yes	778.7	983.2	1.008	Say OK
Story3	13.5	27	D21	A15.5	890.8625	-809.875	0.7854	57.27	386.6	79.5	5	0.25	346.96	601.30	CT3	W16X100	5.29	23.2	0.450	Yes	778.7	983.2	1.008	Say OK
Story2	13.5	27	D21	A15.5	890.8625	-809.875	0.7854	57.27	386.6	79.5	5	0.25	346.96	601.30	CT3	W16X100	5.29	23.2	0.450	Yes	778.7	983.2	1.008	Say OK
Story1	18	27	D21	A15.5	890.8625	-809.875	0.9273	64.79	437.3	79.5	5	0.25	397.74	510.22	CT3	W16X100	5.29	23.2	0.382	Yes	778.7	983.2	0.973	OK
Ground	12	27	D21	A15.5	890.8625	-809.875	0.7266	53.81	363.2	480	9.75		77.03	635.57	CT3	W16X100	5.29	23.2	0.476	Yes	778.7	983.2	0.734	OK
B1	12	27	D21	A15.5	890.8625	-809.875	0.7266	53.81	363.2	54.5	9.75		330.69	635.57	CT3	W16X100	5.29	23.2	0.476	Yes	778.7	983.2	1.024	Say OK
B2	12	27	D21	A15.5	890.8625	-809.875	0.7266	53.81	363.2	54.5	9.75		330.69	635.57	CT3	W16X100	5.29	23.2	0.476	Yes	778.7	983.2	1.024	Say OK
B3	12	27	D21	A15.5	890.8625	-809.875	0.7266	53.81	363.2	54.5	9.75		330.69	635.57	CT3	W16X100	5.29	23.2	0.476	Yes	778.7	983.2	1.024	Say OK

Floor	Height (ft)	Beam Span (ft)	Brace Label	Brace Sec.	Comp Cap (kips)	Tens Cap (kips)	Brace Angle (radians)	Unb. Up F (kips)	Unb Moment (kip-ft)	Dead Load (psf)	Trib Width (ft)	Addl Dead Line (kips/ft)	Total Moment (kip-ft)	Beam Comp. (kips)	Collector	Beam	bf/2f	h/tw	Ca	Seismically Compact	φMn (kip-ft)	φPcr (kips)	Interaction	Comment
Story10	13.5	40	D25	A25	1436.875	-1306.25	0.5937	73.08	730.8	80	5	0.25	643.58	1136.82	CT14	W14X176	5.97	13.7	0.488	Yes	1333.3	2184.0	0.950	OK
Story9	13.5	40	D25	A25	1436.875	-1306.25	0.5937	73.08	730.8	79.5	5	0.25	643.92	1136.82	CT14	W14X176	5.97	13.7	0.488	Yes	1333.3	2184.0	0.950	OK
Story8	13.5	40	D25	A25	1436.875	-1306.25	0.5937	73.08	730.8	79.5	5	0.25	643.92	1136.82	CT14	W14X176	5.97	13.7	0.488	Yes	1333.3	2184.0	0.950	OK
Story7	13.5	40	D25	A27	1551.825	-1410.75	0.5937	78.93	789.3	79.5	5	0.25	702.38	1227.76	CT15	W14X193	5.45	12.8	0.480	Yes	1479.2	2397.1	0.934	OK
Story6	13.5	40	D25	A27	1551.825	-1410.75	0.5937	78.93	789.3	79.5	5	0.25	702.38	1227.76	CT15	W14X193	5.45	12.8	0.480</					

Model: 011609PBModel1
Scale-X= 1.00
Scale-Y= 1.00
SDS = 1.145
p-X dir = 1
p-Y dir = 1

0.9	0.9	0.9	0.9	0.9	0.9	0.9	0.9	0.9	0.9	0.9	0.9	0.9	0.9	0.9	0.9	0.9	0.9	0.9	1	1	1	1	1	1	1	1	1	1
0.9008	0.9008	-0.9008	-0.9008	0.9008	0.9008	0.9008	0.9008	-0.9008	-0.9008	0.9008	0.9008	-0.9008	-0.9008	0.9008	0.9008	-0.9008	-0.9008	0.9008	0.25	0.25	0.25	0.25	0.25	0.25	0.25	0.25	0.25	0.25
0.9008	-0.9008	0.9008	0.9008	-0.9008	-0.9008	0.9008	0.9008	0.9008	-0.9008	-0.9008	0.9008	0.9008	-0.9008	-0.9008	0.9008	0.9008	-0.9008	-0.9008	0.9008									
0.9008	0.9008	0.9008	0.9008	-0.9008	-0.9008	0.9008	0.9008	0.9008	-0.9008	-0.9008	0.9008	0.9008	-0.9008	-0.9008	0.9008	0.9008	-0.9008	-0.9008	0.9008									
0.9008	-0.9008	0.9008	0.9008	-0.9008	-0.9008	0.9008	0.9008	0.9008	-0.9008	-0.9008	0.9008	0.9008	-0.9008	-0.9008	0.9008	0.9008	-0.9008	-0.9008	0.9008									
																				1	0.3	-1	-0.3	0.3	1	-1	-0.3	-1
																				0.3	1	0.3	1	-1	-0.3	-0.3	-1	-1

Figure 6-9 Case 4

Story	ETABS #	Section	Capacity	Dead	Live	WindFX	WindMTX	WindFY	WindMTY	Maximum Axial Loads																												Status
										Tension	Compression	DCR	Tension	Compression	DCR	Tension	Compression	DCR	Tension	Compression	DCR	Tension	Compression	DCR	Tension	Compression	DCR	Tension	Compression	DCR	Tension	Compression	DCR	Tension	Compression	DCR		
Story40	D18	A7	239	-2.99	0.00	0.00	7.88	-10.30	22.66	15.5	1.3	15.5	1.3	-25.3	34.1	-6.7	-20.9	-6.7	-20.9	39.5	19.9	-39.5	19.9	-25.3	34.1	16.7	62.5	16.7	62.5	-68.5	-22.6	-22.7	-68.5	62.55	-68.53	0.29	OK	
Story39	D18	A7	239	-3.45	-0.07	0.01	8.82	-18.43	25.36	11.1	4.8	11.1	4.8	-34.6	44.3	-1.4	-17.3	-1.4	-17.3	50.5	28.4	-50.5	28.4	-34.6	44.3	19.9	74.0	19.6	73.9	-80.8	-24.5	-24.8	-80.9	73.99	-80.92	0.34	OK	
Story38	D18	A9	308	-4.00	-0.14	0.02	12.10	-32.87	34.79	9.1	-12.8	9.0	-12.8	9.0	-53.6	68.3	5.6	-16.3	5.6	-16.2	-75.4	46.4	-75.5	46.5	-53.7	68.2	33.0	118.6	32.4	118.4	-126.5	-40.5	-41.1	-126.6	118.57	-126.64	0.41	OK
Story37	D18	A9	308	-4.47	-0.21	0.05	12.98	-43.58	37.29	2.1	-21.3	2.0	-21.4	65.1	80.6	13.4	-10.1	13.3	-10.0	-88.5	57.1	-88.6	57.2	-65.2	80.5	36.0	129.2	35.1	128.9	-137.9	-44.1	-45.1	-138.2	129.18	-138.23	0.45	OK	
Story36	D18	A9	308	-4.94	-0.28	0.09	14.26	-54.09	40.97	-3.3	-29.0	-3.5	-29.2	-77.1	94.1	20.3	-5.6	20.1	-5.4	-102.8	68.3	-103.0	68.4	-77.3	93.9	39.7	141.9	38.3	141.5	-151.5	-48.3	-49.7	-151.9	141.91	-151.92	0.49	OK	
Story35	D18	A9	308	-5.41	-0.35	0.15	15.48	-60.61	44.47	-5.3	-33.2	-5.6	-33.5	-85.4	103.9	23.7	-4.4	23.5	-4.1	-113.3	75.7	-113.6	76.0	-85.7	103.6	38.9	139.4	36.9	138.8	-149.8	-47.9	-49.9	-150.4	139.43	-150.42	0.49	OK	
Story34	D18	A9	308	-5.88	-0.41	0.21	16.35	-70.84	46.97	-11.9	-41.3	-12.3	-41.7	-96.5	115.7	31.1	1.3	30.8	1.7	-125.9	85.9	-126.3	86.3	-96.9	115.4	40.3	144.6	37.8	143.8	-155.8	-49.8	-52.3	-156.6	144.60	-156.56	0.51	OK	
Story33	D18	A9	308	-5.64	-0.40	0.23	17.58	-81.06	50.51	-16.6	-48.2	-17.0	-48.6	-107.5	129.5	38.5	6.4	38.1	6.8	-139.2	97.4	-139.6	97.8	-108.0	129.1	42.0	149.6	39.5	148.8	-160.3	-50.9	-53.5	-161.0	152.81	-165.04	0.54	OK	
Story32	D18	A9	308	-6.05	-0.45	0.30	18.84	-91.74	54.14	-22.1	-56.0	-22.6	-56.6	-119.6	143.2	45.7	11.2	45.1	11.7	-153.6	108.7	-154.1	109.3	-120.1	142.7	42.3	150.8	39.2	149.8	-162.1	-51.6	-54.6	-163.1	169.61	-182.76	0.59	OK	
Story31	D18	A9	308	-5.36	-0.37	0.27	20.12	-101.29	57.82	-25.6	-61.9	-26.1	-62.4	-129.8	156.9	52.7	16.0	52.2	16.5	-166.0	120.1	-166.5	120.6	-130.3	156.4	43.0	152.2	40.4	151.4	-162.3	-51.3	-53.9	-163.1	186.10	-197.73	0.64	OK	
Story30	D18	A9	308	-5.66	-0.41	0.33	21.19	-109.74	60.88	-29.7	-67.9	-30.3	-68.5	-139.4	168.0	58.3	19.5	57.7	20.1	-177.6	129.2	-178.2	129.8	-140.0	167.4	42.0	148.7	38.9	147.8	-159.3	-50.5	-53.5	-160.2	199.65	-211.95	0.69	OK	
Story29	D18	A11	376	-5.56	-0.40	0.35	26.26	-137.17	75.47	-36.6	-83.9	-37.3	-84.6	-172.6	210.5	74.5	26.6	73.9	27.2	-219.9	162.6	-220.5	163.2	-173.2	209.9	48.8	171.4	45.8	170.5	-181.8	-57.1	-60.1	-182.7	250.16	-262.24	0.70	OK	
Story28	D18	A11	376	-5.83	-0.43	0.42	27.18	-144.54	78.15	-40.2	-89.2	-40.9	-89.9	-181.0	220.2	79.4	29.7	78.7	30.4	-230.0	170.5	-230.7	171.2	-181.7	219.5	46.9	164.9	43.5	163.9	-175.8	-55.4	-58.7	-176.8	261.98	-274.67	0.73	OK	
Story27	D18	A11	376	-5.32	-0.37	0.38	27.11	-145.02	77.96	-40.4	-89.3	-41.1	-89.9	-180.9	220.8	80.4	30.9	79.7	31.5	-229.7	171.3	-230.4	172.0	-181.6	220.1	43.0	151.6	40.1	150.7	-161.5	-50.9	-53.8	-162.4	262.79	-274.32	0.73	OK	
Story26	D18	A11	376	-5.54	-0.40	0.45	27.97	-152.23	80.47	-44.0	-94.4	-44.8	-95.2	-189.0	230.2	85.2	34.1	84.4	34.9	-239.4	179.0	-240.2	179.8	-189.8	229.4	42.3	149.1	39.0	148.2	-159.5	-50.3	-53.5	-160.4	274.26	-286.30	0.76	OK	
Story25	D18	A11	376	-5.77	-0.43	0.51	29.02	-161.51	83.50	-48.9	-101.1	-49.8	-102.1	-199.3	242.1	91.7	38.5	90.8	39.4	-251.6	188.9	-252.5	189.8	-200.2	241.2	42.1	148.7	38.6	147.7	-159.4	-50.3	-53.9	-160.5	288.81	-301.36	0.80	OK	
Story24	D18	A11	376	-6.00	-0.46	0.58	29.51	-167.36	84.92	-52.6	-105.7	-53.6	-106.8	-205.6	249.0	96.0	41.8	94.9	42.8	-258.7	194.8	-259.8	195.8	-206.6	241.9	41.2	145.8	37.4	144.7	-156.9	-49.6	-53.4	-158.0	297.34	-310.40	0.82	OK	
Story23	D18	A11	376	-5.82	-0.43	0.58	28.27	-162.21	81.41	-52.0	-103.0	-53.1	-104.0	-198.7	240.2	93.5	41.6	92.5	42.6	-249.6	188.2	-250.7	189.3	-199.8	239.2	38.0	135.1	34.4	134.0	-145.9	-46.2	-49.9	-146.9	287.10	-299.77	0.80	OK	
Story22	D18	A11	376	-6.04	-0.46	0.65	28.48	-166.63	82.03	-55.4	-106.7	-56.6	-107.9	-203.2	244.8	97.0	44.5	95.8	45.7	-254.5	192.3	-255.7	193.5	-204.4	243.6	37.7	134.0	33.8	132.8	-145.1	-46.1	-50.0	-146.3	292.96	-306.11	0.81	OK	
Story21	D18	A11	376	-6.26	-0.49	0.73	29.09	-173.90	83.81	-59.9	-112.3	-61.2	-113.6	-210.9	253.4	102.4	48.7	101.1	50.0	-263.3	199.6	-264.6	201.0	-212.2	252.1	38.3	136.1	34.1	134.9	-147.7	-46.9	-51.0	-148.9	303.62	-317.25	0.84	OK	
Story20	D18	A11	376	-6.48	-0.51	0.81	29.67	-178.34	85.49	-62.0	-115.5	-63.5	-116.9	-216.0	259.3	105.3	50.4	103.8	51.8	-269.5	204.4	-270.9	205.8	-217.5	257.8	38.1	135.7	33.7	134.4	-147.6	-46.9	-51.3	-148.9	310.77	-324.89	0.86	OK	
Story19	D18	A11	376	-6.26	-0.49	0.80	30.12	-184.43	86.80	-65.7	-120.0	-67.2	-121.4	-222.1	266.5	110.2	54.5	108.7	55.9	-276.4	210.8	-277.8	212.3	-223.5	265.1	39.1	138.8	34.9	137.6	-150.3	-47.7	-51.8	-151.6	319.85	-333.47	0.89	OK	
Story18	D18	A11	376	-6.46	-0.51	0.87	30.55	-192.70	88.06	-71.8	-126.8	-73.3	-128.4	-230.4	275.4	116.7	60.1	115.2	61.7	-285.4	218.8	-287.0	220.4	-232.0	273.8	40.4	143.4	36.0	142.0	-155.2	-49.2	-53.6	-156.5	331.09	-345.17	0.92	OK	
Story17	D18	A11	376	-5.95	-0.45	0.80	30.80	-197.43	88.81	-74.7	-130.2	-76.2	-131.7	-234.7	281.0	121.0	64.0	119.5	65.5	-290.2	224.0	-291.7	225.5	-236.2	275.5	42.2	148.8	38.3	147.7	-159.8	-50.4	-54.3	-160.9	338.14	-351.08	0.93	OK	
Story16	D18	A11	376	-6.13	-0.47	0.87	31.06	-202.98	89.61	-78.9	-134.8	-80.4	-136.4	-240.3	286.8	125.4	67.8	123.8	69.4	-298.7	229.3	-299.8	230.8	-241.9	285.2	43.7	154.0	39.6	152.8	-165.3	-52.1	-56.1	-166.5	354.59	-368.92	0.95	OK	
Story15	D18	A11	376	-6.30	-0.49	0.94	31.28	-209.50	90.27	-84.1	-140.4	-85.7	-142.1	-246.7	293.4	130.8	72.7	129.1	74.4	-303.0	235.3	-304.7	237.0	-248.4	291.7	45.4	160.0	41.2	158.7	-171.6	-54.1	-58.2	-172.8	354.05	-367.78	0.98	OK	
Story14	D18	A11	376	-6.49	-0.51	1.01	31.44	-216.10	90.74	-89.5	-146.2	-91.4	-148.0	-253.0	299.8	136.3	77.8	134.5	79.7	-309.7	241.3	-311.5	243.1	-254.8	299.0	47.1	165.9	42.7	164.6	-177.8	-56.0	-60.3	-179.1	362.36	-376.51	1.00	Say OK	
Story13	D18	A11	376	-6.31	-0.48	1.00	31.23	-218.12	90.17	-91.9	-148.2	-93.7	-150.0	-254.3	301.1	138.6	80.5	136.8	82.4	-310.6	243.0	-312.4	244.8	-256.1	299.3	48.5	170.3	44.3	169.0	-181.9	-57.2	-61.3	-183.1	364.26	-377.99			

**APPENDIX D: Program Cost Model for PEER
Tall Buildings Study, Concrete
Option, Los Angeles, California**

Davis Langdon 

**PROGRAM
COST MODEL**

for

**PEER Tall Buildings Study
Concrete Structural Option
Los Angeles, California**

March 8, 2010

CONTENTS

	Page Nos.
Overall Summary	1
Areas and Control Quantities	2
Code Based Component Summary	3
Performance Based Component Summary	14
Performance Based Plus Component Summary	25

OVERALL SUMMARY

	Gross Floor Area	\$ / SF	\$x1,000
Construction Cost (Including Design)			
Code Based	683,748 SF	325.77	222,744
Performance Based	683,748 SF	324.89	222,142
Performance Based Plus	683,748 SF	331.60	226,728
FF&E Cost			
Furniture & Fittings, (residential)	476,716 SF	20.00	9,534
Equipment, including computer systems	476,716 SF	7.00	3,337
Personal Property			
Personal Contents	476,716 SF	10.00	4,767
Cars in parking (Maximum count)	520 EA	25,000.00	13,000

Please refer to the Inclusions and Exclusions sections of this report

AREAS & CONTROL QUANTITIES

Areas

	SF	SF	SF
Enclosed Areas			
Basement Levels B1 - B4	207,024		
Ground Level	11,314		
Levels 2 - 42	463,874		
Penthouse	1,536		
SUBTOTAL, Enclosed Area		683,748	
Covered area			
SUBTOTAL, Covered Area @ ½ Value			
TOTAL GROSS FLOOR AREA		683,748	

Control Quantities

			Ratio to Gross Area
Functional Units	310 Units		
Number of stories (x1,000)	46 EA		0.067
Gross Area	683,748 SF		1.000
Enclosed Area	683,748 SF		1.000
Covered Area	0 SF		0.000
Footprint Area	51,756 SF		0.076
Volume	7,212,004 CF		10.548
Basement Volume	2,070,240 CF		3.028
Gross Wall Area	212,093 SF		0.310
Retaining Wall Area	36,000 SF		0.053
Finished Wall Area	168,413 SF		0.246
Windows or Glazing Area	19.28% 40,883 SF		0.060
Roof Area - Flat	51,756 SF		0.076
Roof Area - Sloping	0 SF		0.000
Roof Area - Total	51,756 SF		0.076
Roof Glazing Area	0 SF		0.000
Interior Partition Length	132,334 LF		0.194
Finished Area	683,748 SF		1.000
Elevators (x10,000)	6 EA		0.088
Plumbing Fixtures (x1,000)	2,914 EA		4.262
Electrical Load	6,000 KW		8.775

CODE BASED COMPONENT SUMMARY

Gross Area: 683,748 SF

		\$/SF	\$x1,000
1. Foundations		16.35	11,178
2. Vertical Structure		17.64	12,060
3. Floor & Roof Structures		30.96	21,167
4. Exterior Cladding		33.35	22,803
5. Roofing, Waterproofing & Skylights		3.95	2,699
Shell (1-5)		102.24	69,907
6. Interior Partitions, Doors & Glazing		24.75	16,922
7. Floor, Wall & Ceiling Finishes		21.25	14,530
Interiors (6-7)		46.00	31,452
8. Function Equipment & Specialties		5.73	3,919
9. Stairs & Vertical Transportation		10.41	7,120
Equipment & Vertical Transportation (8-9)		16.15	11,039
10 Plumbing Systems		19.04	13,015
11 Heating, Ventilating & Air Conditioning		13.86	9,475
12 Electric Lighting, Power & Communications		21.33	14,586
13 Fire Protection Systems		5.37	3,669
Mechanical & Electrical (10-13)		59.59	40,745
Total Building Construction (1-13)		223.98	153,144
14 Site Preparation & Demolition		2.19	1,500
15 Site Paving, Structures & Landscaping		1.76	1,206
16 Utilities on Site		0.73	500
Total Site Construction (14-16)		4.69	3,206
TOTAL BUILDING & SITE (1-16)		228.67	156,351
General Conditions	12.00%	27.44	18,762
Contractor's Overhead & Profit or Fee	6.00%	15.37	10,507
PLANNED CONSTRUCTION COST		March 2010	271.47
Design, Management and Inspection	20.00%	54.29	37,124
Escalation is excluded	0.00%	0.00	0
RECOMMENDED BUDGET		March 2010	325.77
			222,744

<i>Item Description</i>	<i>Quantity</i>	<i>Unit</i>	<i>Rate</i>	<i>Total</i>
1. Foundations				
Basement Excavation				
Excavation	99,173	CY	15.00	1,487,595
Shoring at perimeter	36,400	SF	50.00	1,820,000
Backfill with imported material	14,829	CY	35.00	519,015
Dispose off site	99,173	CY	20.00	1,983,460
Hazardous material remediation				Excluded
Foundations				
Reinforced concrete mat foundation				
Excavation and disposal	10,278	CY	15.00	154,170
Formwork	5,240	SF	18.00	94,320
Reinforcing steel	1,469,135	LBS	1.15	1,689,505
Concrete, f'c= 6ksi	10,278	CY	325.00	3,340,350
Elevator pits	6	EA	15,000.00	90,000
				11,178,415
2. Vertical Structure				
Columns and pilasters				
Concrete columns				
Formwork	99,875	SF	25.00	2,496,875
Reinforcing steel	972,895	LBS	1.25	1,216,119
Concrete, f'c= 8ksi	2,048	CY	350.00	716,800
Concrete retaining walls				
Concrete retaining wall				
Formwork to one side	36,400	SF	15.00	546,000
Reinforcing steel	240,240	LBS	1.25	300,300
Concrete, f'c= 5ksi	1,978	CY	225.00	445,050
Concrete core walls				
Formwork to both sides	157,864	SF	18.00	2,841,552
Reinforcing steel	1,171,663	LBS	1.25	1,464,579
Concrete, f'c= 8ksi	5,808	CY	350.00	2,032,800
				12,060,075

<i>Item Description</i>	<i>Quantity</i>	<i>Unit</i>	<i>Rate</i>	<i>Total</i>
3. Floor and Roof Structure				
Floor at lowest level				
Slab on grade - See foundations (mat slab)				
Suspended floors	21,103			
10" thick reinforced concrete flat slab - basement slabs				
Formwork	155,268	SF	10.00	1,552,680
Reinforcing steel	768,577	LBS	1.25	960,721
Concrete, f'c= 5.5ksi	4,792	CY	225.00	1,078,200
8" thick post tensioned slabs				
Formwork	463,874	SF	10.00	4,638,740
Reinforcing steel	1,122,575	LBS	1.25	1,403,219
Post tension tendons	459,236	LBS	2.00	918,472
Studrails at columns (9 studrais with 9 studs per rail)	1,476	LOC	4,000.00	5,904,000
Concrete, f'c= 5.5ksi	12,599	CY	225.00	2,834,775
Ground level slab/roof				
12" thick reinforced concrete flat slab - ground level				
Formwork	51,756	SF	10.00	517,560
Reinforcing steel	455,453	LBS	1.25	569,316
Concrete, f'c= 5.5ksi	2,109	CY	225.00	474,525
High roof				
10" thick reinforced concrete flat slab				
Formwork	12,850	SF	10.00	128,500
Reinforcing steel	70,675	LBS	1.25	88,344
Concrete, f'c= 5.5ksi	437	CY	225.00	98,325
				21,167,377

4. Exterior Cladding

Wall framing, furring and insulation				
Exterior wall framing	168,413	SF	8.00	1,347,304
Furring to interior face of retaining wall	36,000	SF	4.00	144,000
Insulation and vapor barrier	161,050	SF	1.50	241,575

<i>Item Description</i>	<i>Quantity</i>	<i>Unit</i>	<i>Rate</i>	<i>Total</i>
Applied exterior finishes				
Exterior wall finish - curtain wall with spandrel panels	125,050	SF	120.00	15,006,000
Parapets & edge detailing	400	LF	250.00	100,000
Interior finish to exterior walls				
Gypsum board, taped and sanded	161,050	SF	3.50	563,675
Windows, glazing and louvers				
Exterior wall finish - curtain wall with glazing	40,883	SF	120.00	4,905,960
Exterior doors, frames and hardware				
Glazed Doors & Entrances (allow revolving)	12	EA	35,000.00	420,000
Solid Exterior Doors	8	EA	3,000.00	24,000
Overhead Doors	2	EA	25,000.00	50,000
				22,802,514

5. Roofing, Waterproofing & Skylights

Waterproofing				
Waterproofing at slab on grade	51,756	SF	10.00	517,560
Waterproofing at retaining wall	36,000	SF	10.00	360,000
Waterproofing membrane under plaza	40,442	SF	15.00	606,630
Insulation				
Rigid insulation at roof	11,314	SF	6.00	67,884
Roofing				
Balconies & accessible roofs	40,442	SF	25.00	1,011,050
High roof	11,314	SF	12.00	135,768
				2,698,892

6. Interior Partitions, Doors & Glazing

Partition framing and cores				
CMU partitions at basement levels	1,656	LF	325.00	538,200
Core partitions	11,880	LF	90.00	1,069,200
Standard partitions	118,798	LF	72.00	8,553,456

<i>Item Description</i>	<i>Quantity</i>	<i>Unit</i>	<i>Rate</i>	<i>Total</i>
Doors, frames & hardware				
Unit entrance doors	310	EA	2,250.00	697,500
Standard interior doors	2,680	EA	1,800.00	4,824,000
Closet doors at units - allow bi-fold	1,240	EA	1,000.00	1,240,000
				16,922,356

7. Floor, Wall & Ceiling Finishes

Floors including base				
Lobby flooring	5,000	SF	35.00	175,000
Core circulation - allow carpet	70,530	SF	6.00	423,180
Residential				
Livingrooms - allow wood	141,050	SF	22.00	3,103,100
Bedrooms - allow carpet	164,565	SF	6.00	987,390
Kitchen - allow stone tile	42,315	SF	25.00	1,057,875
Bathrooms - allow porcelain tile	47,020	SF	20.00	940,400
Special use areas	6,236	SF	10.00	62,360
Concrete sealer at basement	207,024	SF	2.00	414,048
Walls				
Lobby	1	EA	75,000.00	75,000
Core circulation	141,060	SF	3.00	423,180
Residential				
Livingrooms	282,100	SF	2.00	564,200
Bedrooms	329,130	SF	1.00	329,130
Kitchen	84,630	SF	10.00	846,300
Bathrooms	94,040	SF	12.00	1,128,480
Special use areas	9,354	SF	12.00	112,248
Paint to concrete and CMU at basement	70,776	SF	1.00	70,776
Ceilings				
Lobby	5,000	SF	25.00	125,000
Core circulation	70,530	SF	12.00	846,360
Residential				
Livingrooms	141,050	SF	6.00	846,300
Bedrooms	164,565	SF	6.00	987,390
Kitchen	42,315	SF	6.00	253,890
Bathrooms	47,020	SF	6.00	282,120
Special use areas	6,236	SF	10.00	62,360
Paint to exposed structure at basement	207,024	SF	2.00	414,048
				14,530,135

<i>Item Description</i>	<i>Quantity</i>	<i>Unit</i>	<i>Rate</i>	<i>Total</i>
8. Function Equipment & Specialties				
Specialties				
Fire extinguisher cabinets	150	EA	450.00	67,500
Trash chute	1	EA	110,000.00	110,000
Parking Garage equipment	1	LS	25,000.00	25,000
Built in Equipment				
Lobby/entry	1	LS	25,000.00	25,000
Core area	70,530	SF	0.75	52,898
Residential				
Livingrooms	141,050	SF	0.05	7,053
Bedrooms	164,565	SF	0.10	16,457
Bathrooms	47,020	SF	1.00	47,020
Kitchen	42,315	EA	6.00	253,890
Special use areas	6,236	SF	2.00	12,472
Residential appliances				
Kitchen appliances				
Refrigerator	310	EA	1,700.00	527,000
Range	310	EA	2,000.00	620,000
Range hood	310	EA	1,000.00	310,000
Double oven	310	EA	800.00	248,000
Dishwasher	310	EA	850.00	263,500
Microwave	310	EA	450.00	139,500
Washing machine	310	EA	1,200.00	372,000
Dryer - electric	310	EA	1,200.00	372,000
Window washing equipment	1	LS	450,000.00	450,000
				3,919,289

9. Stairs & Vertical Transportation

Stairs				
Regular stair flights	88	EA	22,000.00	1,936,000
Elevators				
Passenger Elevators, gearless traction	176	STOP	28,000.00	4,928,000
Freight Elevators, geared traction, 4 stop	8	STOP	32,000.00	256,000
				7,120,000

<i>Item Description</i>	<i>Quantity</i>	<i>Unit</i>	<i>Rate</i>	<i>Total</i>
10. Plumbing Systems				
Sanitary fixtures and connection piping				
Toilets	736	EA	1,600.00	1,177,600
Lavatories	736	EA	1,200.00	883,200
Tub/shower combo	580	EA	1,800.00	1,044,000
Showers	232	EA	350.00	81,200
Kitchen sinks	310	EA	1,700.00	527,000
Washing machine connection	310	EA	350.00	108,500
Hose bibbs	10	EA	500.00	5,000
Domestic water and distribution				
Cold Water Service				
Copper piping incl. fittings >2"	900	LF	50.00	45,000
Copper piping incl. fittings to 2"	58,280	LF	32.00	1,864,960
Hot Water Service				
Copper piping incl. fittings >2"	1,400	LF	50.00	70,000
Copper piping incl. fittings to 2"	65,040	LF	32.00	2,081,280
Insulation	66,440	LF	9.00	597,960
Valves				
Isolation valves to 3/4"	4,772	EA	65.00	310,180
Domestic Water Supply Equipment				
Hot water heating and circulation	310	EA	900.00	279,000
Sanitary waste				
Waste & vent pipework-above ground				
Cast Iron No Hub, >6"	900	LF	75.00	67,500
Cast Iron No Hub, to 3"	58,280	LF	32.00	1,864,960
Sanitary waste, vent and service piping				
Floor Drains	88	EA	1,000.00	88,000
Rain Water Drainage				
Pipe and Fittings	51,583	LF	35.00	1,805,422
Roof/Overflow Drains	86	EA	750.00	64,695
Gas distribution				
Copper piping incl. fittings to 2"	2,000	LF	25.00	50,000
				13,015,457

<i>Item Description</i>	<i>Quantity</i>	<i>Unit</i>	<i>Rate</i>	<i>Total</i>
11. Heating, Ventilation & Air Conditioning				
Heat generating systems				
Heating hot water boilers, high efficiency condensing: Core Area only	3,700	MBTH	25.00	92,500
Heating hot water pumps	2	EA	15,000.00	30,000
Cooling Generating Systems: Core Area only				
Cooling towers	500	TN	250.00	125,000
Chillers, 2 each	500	TN	450.00	225,000
Chilled water pumps	2	EA	10,000.00	20,000
Condenser water pumps	2	EA	5,000.00	10,000
Variable speed drives, vibration isolation, etc.	6	EA	12,000.00	72,000
Distribution systems: Core Area only				
Piping, fittings, valves and insulation				
Chilled water				
Chilled water pipework, fittings	1,400	LF	95.00	133,000
Valves and specialties	1	LS	75,000.00	75,000
Heating hot water				
Heating hot water pipework, fittings, including insulation				
6" - 4"	1,200	LF	85.00	102,000
< = 3"	4,000	LF	30.00	120,000
Valves and specialties	1	LS	25,000.00	25,000
Condenser water				
Condenser water pipework, fittings	1,200	LF	90.00	108,000
Valves and specialties	1	LS	25,000.00	25,000
Connections to Fan Coil Boxes	164	EA	350.00	57,236
Air handling equipment				
Dedicated outside air supply air handler	220,000	CFM	5.00	1,100,000
Individual unit packaged units	310	EA	6,000.00	1,860,000
Fan Coil Units				
Core/Shell	164	EA	1,250.00	204,415
Parking area	207	EA	1,250.00	258,750
Sound attenuation - duct mounted	220,000	CFM	0.25	55,000
Air distribution, return and exhaust				
Galvanized sheet metal ductwork	288,790	LB	8.00	2,310,320
Dryer exhaust duct	9,300	LF	6.00	55,800
Flexible ductwork	3,000	LF	6.00	18,000
Dampers, volume	100	EA	40.00	4,000
Dampers, smoke/fire	80	EA	1,200.00	96,000
Insulation/duct liner	100,000	SF	2.50	250,000

<i>Item Description</i>	<i>Quantity</i>	<i>Unit</i>	<i>Rate</i>	<i>Total</i>
Diffusers, registers and grilles				
Ceiling				
Core/Shell	818	EA	200.00	163,532
Tenant areas, 1 per 150 USF	2,633	EA	150.00	394,950
Parking area				
Terminal & Package Units				
Exhaust fans at toilet rooms	736	EA	350.00	257,600
Controls and instrumentation				
DDC Control system	288,790	SF	3.00	866,370
Test and balance				
Test and balance	288,790	SF	1.25	360,988
				9,475,461

12. Electrical Lighting, Power & Communication

Primary Service, Medium voltage				
Switchgear 13.8KV including (2) tie breakers, (2) feeder breakers, and customer metering	6,000	KVA	60.00	360,000
Transformer substation 13.8KV/110-208V, double-ended including secondary distribution	6,000	KVA	150.00	900,000
Distribution switchboards - 110-208V	18,600	AMP	25.00	465,000
Distribution panelboards - 208V	310	EA	1,500.00	465,000
Feeder conduit and wire - 600V	45,000	LF	80.00	3,600,000
Emergency and Uninterrupted Power				
Emergency Generator	1,500	KVA	350.00	525,000
Automatic transfer switch	1,500	AMP	45.00	67,500
Distribution panelboards	1,500	AMP	25.00	37,500
General Purpose Lighting				
Panelboards	46	EA	2,500.00	115,000
Lighting				
Core Area	81,766	SF	12.00	981,192
Tenant Area	394,950	SF	2.00	789,900
Parking area	207,024	SF	4.00	828,096

<i>Item Description</i>	<i>Quantity</i>	<i>Unit</i>	<i>Rate</i>	<i>Total</i>
Machine and Equipment Power				
Connections and switches including conduit and wire				
Elevators	16	EA	1,000.00	16,000
Cooling towers	2	EA	5,000.00	10,000
Chillers	2	EA	12,000.00	24,000
Pumps	6	EA	2,000.00	12,000
Miscellaneous connections	683,748	SF	0.75	512,811
User Convenience Power				
Panelboards	46	EA	2,500.00	115,000
Receptacles				
Core/Shell	81,766	SF	3.00	245,298
Tenant Area	394,950	SF	3.00	1,184,850
Parking area	207,024	SF	2.00	414,048
Communications				
Telephone and communications				
Core Area, panels and backbone only	1	LS	75,000.00	75,000
Tenant Units	310	EA	800.00	248,000
Security Systems				
Main Security System	683,748	SF	0.10	68,375
Tenant Units	310	EA	900.00	279,000
Fire Alarm Systems				
Main Fire Alarm Systems	683,748	SF	3.00	2,051,244
Other Electrical Systems				
Grounding Systems	683,748	SF	0.25	170,937
Lightning protection	1	LS	25,000.00	25,000
				14,585,751

13. Fire Protection Systems

Sprinkler and Standpipe Systems				
Fire Protection Sprinkler Systems	683,748	SF	4.00	2,734,992
Standpipe and Hose Systems	683,748	SF	1.00	683,748
Specialties and Other Systems				
Smoke Evacuation	1	LS	250,000.00	250,000
				3,668,740

<i>Item Description</i>	<i>Quantity</i>	<i>Unit</i>	<i>Rate</i>	<i>Total</i>
<u>14. Site Preparation & Building Demolition</u>				
Site Preparation	100,000	SF	15.00	1,500,000
				<hr/>
				1,500,000
<u>15. Site Paving, Structures & Landscaping</u>				
Site Development	48,244	SF	25.00	1,206,100
				<hr/>
				1,206,100
<u>16. Utilities on Site</u>				
Site Utilities	1	LS	500,000.00	500,000
				<hr/>
				500,000

PERFORMANCE BASED COMPONENT SUMMARY

Gross Area: 683,748 SF			
		\$/SF	\$x1,000
1. Foundations		18.23	12,462
2. Vertical Structure		19.54	13,362
3. Floor & Roof Structures		26.81	18,333
4. Exterior Cladding		33.35	22,803
5. Roofing, Waterproofing & Skylights		3.69	2,526
<i>Shell (1-5)</i>		101.62	69,486
6. Interior Partitions, Doors & Glazing		24.75	16,922
7. Floor, Wall & Ceiling Finishes		21.25	14,530
<i>Interiors (6-7)</i>		46.00	31,452
8. Function Equipment & Specialties		5.73	3,919
9. Stairs & Vertical Transportation		10.41	7,120
<i>Equipment & Vertical Transportation (8-9)</i>		16.15	11,039
10. Plumbing Systems		19.04	13,015
11. Heating, Ventilating & Air Conditioning		13.86	9,475
12. Electric Lighting, Power & Communications		21.33	14,586
13. Fire Protection Systems		5.37	3,669
<i>Mechanical & Electrical (10-13)</i>		59.59	40,745
Total Building Construction (1-13)		223.36	152,723
14. Site Preparation & Demolition		2.19	1,500
15. Site Paving, Structures & Landscaping		1.76	1,206
16. Utilities on Site		0.73	500
Total Site Construction (14-16)		4.69	3,206
TOTAL BUILDING & SITE (1-16)		228.05	155,929
General Conditions	12.00%	27.37	18,711
Contractor's Overhead & Profit or Fee	6.00%	15.32	10,478
PLANNED CONSTRUCTION COST		March 2010	270.74
Design, Management and Inspection	20.00%	54.15	37,024
Escalation is excluded	0.00%	0.00	0
RECOMMENDED BUDGET		March 2010	324.89
		222,142	

<i>Item Description</i>	<i>Quantity</i>	<i>Unit</i>	<i>Rate</i>	<i>Total</i>
1. Foundations				
Basement Excavation				
Excavation	99,173	CY	15.00	1,487,595
Shoring at perimeter	36,400	SF	50.00	1,820,000
Backfill with imported material	14,829	CY	35.00	519,015
Dispose off site	99,173	CY	20.00	1,983,460
Hazardous material remediation				Excluded
Foundations				
Reinforced concrete Mat foundation				
Excavation and disposal	12,583	CY	15.00	188,745
Forwork	7,240	SF	18.00	130,320
Reinforcing steel	1,872,457	LBS	1.15	2,153,326
Concrete, f'c= 6ksi	12,583	CY	325.00	4,089,475
Elevator pits	6	EA	15,000.00	90,000
				12,461,936

2. Vertical Structure

Columns and pilasters				
Concrete columns				
Forwork	99,875	SF	25.00	2,496,875
Reinforcing steel	972,895	LBS	1.25	1,216,119
Concrete, f'c= 8ksi	2,048	CY	350.00	716,800
Concrete retaining walls				
Concrete retaining wall				
Formwork to one side	36,400	SF	15.00	546,000
Reinforcing steel	240,240	LBS	1.25	300,300
Concrete, f'c= 5ksi	1,978	CY	225.00	445,050
Concrete core walls				
Formwork to both sides	157,864	SF	18.00	2,841,552
Reinforcing steel	1,961,782	LBS	1.25	2,452,228
Concrete, f'c= 8ksi	6,706	CY	350.00	2,347,100
				13,362,023

<i>Item Description</i>	<i>Quantity</i>	<i>Unit</i>	<i>Rate</i>	<i>Total</i>
3. Floor and Roof Structure				
Floor at lowest level				
Slab on grade - See foundations (mat slab)				
Suspended floors				
10" thick reinforced concrete flat slab - basement slabs				
Formwork	155,268	SF	10.00	1,552,680
Reinforcing steel	768,577	LBS	1.25	960,721
Concrete, f'c= 5.5ksi	4,792	CY	225.00	1,078,200
8" thick post tensioned slabs				
Formwork	463,874	SF	10.00	4,638,740
Reinforcing steel	1,122,575	LBS	1.25	1,403,219
Post tension tendons	459,236	LBS	2.00	918,472
Studrails at columns (9 studrais with 9 studs per rail)	1,476	LOC	4,000.00	5,904,000
Concrete, f'c= 5.5ksi	3	CY	225.00	675
Ground level slab/roof				
12" thick reinforced concrete flat slab - ground level				
Formwork	51,756	SF	10.00	517,560
Reinforcing steel	455,453	LBS	1.25	569,316
Concrete, f'c= 5.5ksi	2,109	CY	225.00	474,525
High roof				
10" thick reinforced concrete flat slab				
Formwork	12,850	SF	10.00	128,500
Reinforcing steel	70,675	LBS	1.25	88,344
Concrete, f'c= 5.5ksi	437	CY	225.00	98,325
				18,333,277
4. Exterior Cladding				
Wall framing, furring and insulation				
Exterior wall framing	168,413	SF	8.00	1,347,304
Furring to interior face of retaining wall	36,000	SF	4.00	144,000
Insulation and vapor barrier	161,050	SF	1.50	241,575

<i>Item Description</i>	<i>Quantity</i>	<i>Unit</i>	<i>Rate</i>	<i>Total</i>
Applied exterior finishes				
Exterior wall finish - curtain wall with spandrel panels	125,050	SF	120.00	15,006,000
Parapets & edge detailing	400	LF	250.00	100,000
Interior finish to exterior walls				
Gypsum board, taped and sanded	161,050	SF	3.50	563,675
Windows, glazing and louvers				
Exterior wall finish - curtain wall with glazing	40,883	SF	120.00	4,905,960
Exterior doors, frames and hardware				
Glazed Doors & Entrances (allow revolving)	12	EA	35,000.00	420,000
Solid Exterior Doors	8	EA	3,000.00	24,000
Overhead Doors	2	EA	25,000.00	50,000
				22,802,514

5. Roofing, Waterproofing & Skylights

Waterproofing				
Waterproofing at slab on grade	49,940	SF	10.00	499,400
Waterproofing at retaining wall	42,912	SF	10.00	429,120
Waterproofing membrane under plaza	31,750	SF	15.00	476,250
Insulation				
Rigid insulation at roof	18,190	SF	6.00	109,140
Roofing				
Balconies & accessible roofs	31,750	SF	25.00	793,750
High roof	18,190	SF	12.00	218,280
				2,525,940

6. Interior Partitions, Doors & Glazing

Partition framing and cores				
CMU partitions at basement levels	1,656	LF	325.00	538,200
Core partitions	11,880	LF	90.00	1,069,200
Standard partitions	118,798	LF	72.00	8,553,456

<i>Item Description</i>	<i>Quantity</i>	<i>Unit</i>	<i>Rate</i>	<i>Total</i>
Doors, frames & hardware				
Unit entrance doors	310	EA	2,250.00	697,500
Standard interior doors	2,680	EA	1,800.00	4,824,000
Closet doors at units - allow bi-fold	1,240	EA	1,000.00	1,240,000
				16,922,356

7. Floor, Wall & Ceiling Finishes

Floors including base				
Lobby flooring	5,000	SF	35.00	175,000
Core circulation - allow carpet	70,530	SF	6.00	423,180
Residential				
Livingrooms - allow wood	141,050	SF	22.00	3,103,100
Bedrooms - allow carpet	164,565	SF	6.00	987,390
Kitchen - allow stone tile	42,315	SF	25.00	1,057,875
Bathrooms - allow ceramic tile	47,020	SF	20.00	940,400
Special use areas	6,236	SF	10.00	62,360
Concrete sealer at basement	207,024	SF	2.00	414,048
Walls				
Lobby	1	EA	75,000.00	75,000
Core circulation	141,060	SF	3.00	423,180
Residential				
Livingrooms	282,100	SF	2.00	564,200
Bedrooms	329,130	SF	1.00	329,130
Kitchen	84,630	SF	10.00	846,300
Bathrooms	94,040	SF	12.00	1,128,480
Special use areas	9,354	SF	12.00	112,248
Paint to concrete and CMU at basement	70,776	SF	1.00	70,776
Ceilings				
Lobby	5,000	SF	25.00	125,000
Core circulation	70,530	SF	12.00	846,360
Residential				
Livingrooms	141,050	SF	6.00	846,300
Bedrooms	164,565	SF	6.00	987,390
Kitchen	42,315	SF	6.00	253,890
Bathrooms	47,020	SF	6.00	282,120
Special use areas	6,236	SF	10.00	62,360
Paint to exposed structure at basement	207,024	SF	2.00	414,048
				14,530,135

<i>Item Description</i>	<i>Quantity</i>	<i>Unit</i>	<i>Rate</i>	<i>Total</i>
8. Function Equipment & Specialties				
Specialties				
Fire extinguisher cabinets	150	EA	450.00	67,500
Trash chute	1	EA	110,000.00	110,000
Parking Garage equipment	1	LS	25,000.00	25,000
Built in Equipment				
Lobby/entry	1	LS	25,000.00	25,000
Core area	70,530	SF	0.75	52,898
Residential				
Livingrooms	141,050	SF	0.05	7,053
Bedrooms	164,565	SF	0.10	16,457
Bathrooms	47,020	SF	1.00	47,020
Kitchen	42,315	EA	6.00	253,890
Special use areas	6,236	SF	2.00	12,472
Residential appliances				
Kitchen appliances				
Refrigerator	310	EA	1,700.00	527,000
Range	310	EA	2,000.00	620,000
Range hood	310	EA	1,000.00	310,000
Double oven	310	EA	800.00	248,000
Dishwasher	310	EA	850.00	263,500
Microwave	310	EA	450.00	139,500
Washing machine	310	EA	1,200.00	372,000
Dryer - electric	310	EA	1,200.00	372,000
Window washing equipment	1	LS	450,000.00	450,000
				3,919,289

9. Stairs & Vertical Transportation

Stairs				
Regular stair flights	88	EA	22,000.00	1,936,000
Elevators				
Passenger Elevators, gearless traction	176	STOP	28,000.00	4,928,000
Freight Elevators, geared traction, 4 stop	8	STOP	32,000.00	256,000
				7,120,000

<i>Item Description</i>	<i>Quantity</i>	<i>Unit</i>	<i>Rate</i>	<i>Total</i>
10. Plumbing Systems				
Sanitary fixtures and connection piping				
Toilets	736	EA	1,600.00	1,177,600
Lavatories	736	EA	1,200.00	883,200
Tub/shower combo	580	EA	1,800.00	1,044,000
Showers	232	EA	350.00	81,200
Kitchen sinks	310	EA	1,700.00	527,000
Washing machine connection	310	EA	350.00	108,500
Hose bibbs	10	EA	500.00	5,000
Domestic water and distribution				
Cold Water Service				
Copper piping incl. fittings >2"	900	LF	50.00	45,000
Copper piping incl. fittings to 2"	58,280	LF	32.00	1,864,960
Hot Water Service				
Copper piping incl. fittings >2"	1,400	LF	50.00	70,000
Copper piping incl. fittings to 2"	65,040	LF	32.00	2,081,280
Insulation	66,440	LF	9.00	597,960
Valves				
Isolation valves to 3/4"	4,772	EA	65.00	310,180
Domestic Water Supply Equipment				
Hot water heating and circulation	310	EA	900.00	279,000
Sanitary waste				
Waste & vent pipework-above ground				
Cast Iron No Hub, >6"	900	LF	75.00	67,500
Cast Iron No Hub, to 3"	58,280	LF	32.00	1,864,960
Sanitary waste, vent and service piping				
Floor Drains	88	EA	1,000.00	88,000
Rain Water Drainage				
Pipe and Fittings	51,583	LF	35.00	1,805,422
Roof/Overflow Drains	86	EA	750.00	64,695
Gas distribution				
Copper piping incl. fittings to 2"	2,000	LF	25.00	50,000
				13,015,457

<i>Item Description</i>	<i>Quantity</i>	<i>Unit</i>	<i>Rate</i>	<i>Total</i>
11. Heating, Ventilation & Air Conditioning				
Heat generating systems				
Heating hot water boilers, high efficiency condensing: Core Area only	3,700	MBTH	25.00	92,500
Heating hot water pumps	2	EA	15,000.00	30,000
Cooling Generating Systems: Core Area only				
Cooling towers	500	TN	250.00	125,000
Chillers, 2 each	500	TN	450.00	225,000
Chilled water pumps	2	EA	10,000.00	20,000
Condenser water pumps	2	EA	5,000.00	10,000
Variable speed drives, vibration isolation, etc.	6	EA	12,000.00	72,000
Distribution systems: Core Area only				
Piping, fittings, valves and insulation				
Chilled water				
Chilled water pipework, fittings	1,400	LF	95.00	133,000
Valves and specialties	1	LS	75,000.00	75,000
Heating hot water				
Heating hot water pipework, fittings, including insulation				
6" - 4"	1,200	LF	85.00	102,000
< = 3"	4,000	LF	30.00	120,000
Valves and specialties	1	LS	25,000.00	25,000
Condenser water				
Condenser water pipework, fittings	1,200	LF	90.00	108,000
Valves and specialties	1	LS	25,000.00	25,000
Connections to Fan Coil Boxes	164	EA	350.00	57,236
Air handling equipment				
Dedicated outside air supply air handler	220,000	CFM	5.00	1,100,000
Individual unit packaged units	310	EA	6,000.00	1,860,000
Fan Coil Units				
Core/Shell	164	EA	1,250.00	204,415
Parking area	207	EA	1,250.00	258,750
Sound attenuation - duct mounted	220,000	CFM	0.25	55,000
Air distribution, return and exhaust				
Galvanized sheet metal ductwork	288,790	LB	8.00	2,310,320
Dryer exhaust duct	9,300	LF	6.00	55,800
Flexible ductwork	3,000	LF	6.00	18,000
Dampers, volume	100	EA	40.00	4,000
Dampers, smoke/fire	80	EA	1,200.00	96,000
Insulation/duct liner	100,000	SF	2.50	250,000

<i>Item Description</i>	<i>Quantity</i>	<i>Unit</i>	<i>Rate</i>	<i>Total</i>
Diffusers, registers and grilles				
Ceiling				
Core/Shell	818	EA	200.00	163,532
Tenant areas, 1 per 150 USF	2,633	EA	150.00	394,950
Parking area				
Terminal & Package Units				
Exhaust fans at toilet rooms	736	EA	350.00	257,600
Controls and instrumentation				
DDC Control system	288,790	SF	3.00	866,370
Test and balance				
Test and balance	288,790	SF	1.25	360,988
				9,475,461

12. Electrical Lighting, Power & Communication

Primary Service, Medium voltage				
Switchgear 13.8KV including (2) tie breakers, (2) feeder breakers, and customer metering	6,000	KVA	60.00	360,000
Transformer substation 13.8KV/110-208V, double-ended including secondary distribution	6,000	KVA	150.00	900,000
Distribution switchboards - 110-208V	18,600	AMP	25.00	465,000
Distribution panelboards - 208V	310	EA	1,500.00	465,000
Feeder conduit and wire - 600V	45,000	LF	80.00	3,600,000
Emergency and Uninterrupted Power				
Emergency Generator	1,500	KVA	350.00	525,000
Automatic transfer switch	1,500	AMP	45.00	67,500
Distribution panelboards	1,500	AMP	25.00	37,500
General Purpose Lighting				
Panelboards	46	EA	2,500.00	115,000
Lighting				
Core Area	81,766	SF	12.00	981,192
Tenant Area	394,950	SF	2.00	789,900
Parking area	207,024	SF	4.00	828,096

<i>Item Description</i>	<i>Quantity</i>	<i>Unit</i>	<i>Rate</i>	<i>Total</i>
Machine and Equipment Power				
Connections and switches including conduit and wire				
Elevators	16	EA	1,000.00	16,000
Cooling towers	2	EA	5,000.00	10,000
Chillers	2	EA	12,000.00	24,000
Pumps	6	EA	2,000.00	12,000
Miscellaneous connections	683,748	SF	0.75	512,811
User Convenience Power				
Panelboards	46	EA	2,500.00	115,000
Receptacles				
Core/Shell	81,766	SF	3.00	245,298
Tenant Area	394,950	SF	3.00	1,184,850
Parking area	207,024	SF	2.00	414,048
Communications				
Telephone and communications				
Core Area, panels and backbone only	1	LS	75,000.00	75,000
Tenant Units	310	EA	800.00	248,000
Security Systems				
Main Security System	683,748	SF	0.10	68,375
Tenant Units	310	EA	900.00	279,000
Fire Alarm Systems				
Main Fire Alarm Systems	683,748	SF	3.00	2,051,244
Other Electrical Systems				
Grounding Systems	683,748	SF	0.25	170,937
Lightning protection	1	LS	25,000.00	25,000
				14,585,751

13. Fire Protection Systems

Sprinkler and Standpipe Systems				
Fire Protection Sprinkler Systems	683,748	SF	4.00	2,734,992
Standpipe and Hose Systems	683,748	SF	1.00	683,748
Specialties and Other Systems				
Smoke Evacuation	1	LS	250,000.00	250,000
				3,668,740

<i>Item Description</i>	<i>Quantity</i>	<i>Unit</i>	<i>Rate</i>	<i>Total</i>
<u>14. Site Preparation & Building Demolition</u>				
Site Preparation	100,000	SF	15.00	1,500,000
				<hr/>
				1,500,000
<u>15. Site Paving, Structures & Landscaping</u>				
Site Development	48,244	SF	25.00	1,206,100
				<hr/>
				1,206,100
<u>16. Utilities on Site</u>				
Site Utilities	1	LS	500,000.00	500,000
				<hr/>
				500,000

PERFORMANCE BASED PLUS COMPONENT SUMMARY

		Gross Area: 683,748 SF	
		\$/SF	\$x1,000
1. Foundations		18.60	12,719
2. Vertical Structure		19.73	13,489
3. Floor & Roof Structures		30.96	21,167
4. Exterior Cladding		33.35	22,803
5. Roofing, Waterproofing & Skylights		3.69	2,526
Shell (1-5)		106.33	72,704
6. Interior Partitions, Doors & Glazing		24.75	16,922
7. Floor, Wall & Ceiling Finishes		21.25	14,530
Interiors (6-7)		46.00	31,452
8. Function Equipment & Specialties		5.73	3,919
9. Stairs & Vertical Transportation		10.41	7,120
Equipment & Vertical Transportation (8-9)		16.15	11,039
10. Plumbing Systems		19.04	13,015
11. Heating, Ventilating & Air Conditioning		13.86	9,475
12. Electric Lighting, Power & Communications		21.33	14,586
13. Fire Protection Systems		5.37	3,669
Mechanical & Electrical (10-13)		59.59	40,745
Total Building Construction (1-13)		228.07	155,941
14. Site Preparation & Demolition		2.19	1,500
15. Site Paving, Structures & Landscaping		1.76	1,206
16. Utilities on Site		0.73	500
Total Site Construction (14-16)		4.69	3,206
TOTAL BUILDING & SITE (1-16)		232.76	159,147
General Conditions	12.00%	27.93	19,098
Contractor's Overhead & Profit or Fee	6.00%	15.64	10,695
PLANNED CONSTRUCTION COST		March 2010	276.33
Design, Management and Inspection	20.00%	55.27	37,788
Escalation is excluded	0.00%	0.00	0
RECOMMENDED BUDGET		March 2010	331.60
			226,728

<i>Item Description</i>	<i>Quantity</i>	<i>Unit</i>	<i>Rate</i>	<i>Total</i>
1. Foundations				
Basement Excavation				
Excavation	99,173	CY	15.00	1,487,595
Shoring at perimeter	36,400	SF	50.00	1,820,000
Backfill with imported material	14,829	CY	35.00	519,015
Dispose off site	99,173	CY	20.00	1,983,460
Hazardous material remediation				
Foundations				
Reinforced concrete Mat foundation				
Excavation and disposal	13,044	CY	15.00	195,660
Formwork	7,640	SF	18.00	137,520
Reinforcing steel	1,953,123	LBS	1.15	2,246,091
Concrete, f'c= 6ksi	13,044	CY	325.00	4,239,300
Elevator pits	6	EA	15,000.00	90,000
				12,718,641
2. Vertical Structure				
Columns and pilasters				
Concrete columns				
Forwork	99,875	SF	25.00	2,496,875
Reinforcing steel	972,895	LBS	1.25	1,216,119
Concrete, f'c= 8ksi	2,048	CY	350.00	716,800
Concrete retaining walls				
Concrete retaining wall				
Formwork to one side	36,400	SF	15.00	546,000
Reinforcing steel	240,240	LBS	1.25	300,300
Concrete, f'c= 5ksi	1,978	CY	225.00	445,050
Concrete core walls				
Formwork to both sides	157,864	SF	18.00	2,841,552
Reinforcing steel	1,961,782	LBS	1.25	2,452,228
Concrete, f'c= 8ksi	7,069	CY	350.00	2,474,150
				13,489,073

<i>Item Description</i>	<i>Quantity</i>	<i>Unit</i>	<i>Rate</i>	<i>Total</i>
3. Floor and Roof Structure				
Floor at lowest level				
Slab on grade - See foundations (mat slab)				
Suspended floors				
10" thick reinforced concrete flat slab - basement slabs				
Formwork	155,268	SF	10.00	1,552,680
Reinforcing steel	768,577	LBS	1.25	960,721
Concrete, f'c= 5.5ksi	4,792	CY	225.00	1,078,200
8" thick post tensioned slabs				
Formwork	463,874	SF	10.00	4,638,740
Reinforcing steel	1,122,575	LBS	1.25	1,403,219
Post tension tendons	459,236	LBS	2.00	918,472
Studrails at columns (9 studrais with 9 studs per rail)	1,476	LOC	4,000.00	5,904,000
Concrete, f'c= 5.5ksi	12,599	CY	225.00	2,834,775
Ground level slab/roof				
12" thick reinforced concrete flat slab - ground level				
Formwork	51,756	SF	10.00	517,560
Reinforcing steel	455,453	LBS	1.25	569,316
Concrete, f'c= 5.5ksi	2,109	CY	225.00	474,525
High roof				
10" thick reinforced concrete flat slab				
Formwork	12,850	SF	10.00	128,500
Reinforcing steel	70,675	LBS	1.25	88,344
Concrete, f'c= 5.5ksi	437	CY	225.00	98,325
				21,167,377

4. Exterior Cladding

Wall framing, furring and insulation				
Exterior wall framing	168,413	SF	8.00	1,347,304
Furring to interior face of retaining wall	36,000	SF	4.00	144,000
Insulation and vapor barrier	161,050	SF	1.50	241,575
Applied exterior finishes				
Exterior wall finish - curtain wall with spandrel panels	125,050	SF	120.00	15,006,000
Parapets & edge detailing	400	LF	250.00	100,000

<i>Item Description</i>	<i>Quantity</i>	<i>Unit</i>	<i>Rate</i>	<i>Total</i>
Interior finish to exterior walls Gypsum board, taped and sanded	161,050	SF	3.50	563,675
Windows, glazing and louvers Exterior wall finish - curtain wall with glazing	40,883	SF	120.00	4,905,960
Exterior doors, frames and hardware Glazed Doors & Entrances (allow revolving)	12	EA	35,000.00	420,000
Solid Exterior Doors	8	EA	3,000.00	24,000
Overhead Doors	2	EA	25,000.00	50,000
				22,802,514

5. Roofing, Waterproofing & Skylights

Waterproofing Waterproofing at slab on grade	49,940	SF	10.00	499,400
Waterproofing at retaining wall	42,912	SF	10.00	429,120
Waterproofing membrane under plaza	31,750	SF	15.00	476,250
Insulation Rigid insulation at roof	18,190	SF	6.00	109,140
Roofing Balconies & accessible roofs	31,750	SF	25.00	793,750
High roof	18,190	SF	12.00	218,280
				2,525,940

6. Interior Partitions, Doors & Glazing

Partition framing and cores CMU partitions at basement levels	1,656	LF	325.00	538,200
Core partitions	11,880	LF	90.00	1,069,200
Standard partitions	118,798	LF	72.00	8,553,456
Doors, frames & hardware Unit entrance doors	310	EA	2,250.00	697,500
Standard interior doors	2,680	EA	1,800.00	4,824,000
Closet doors at units - allow bi-fold	1,240	EA	1,000.00	1,240,000
				16,922,356

<i>Item Description</i>	<i>Quantity</i>	<i>Unit</i>	<i>Rate</i>	<i>Total</i>
7. Floor, Wall & Ceiling Finishes				
Floors including base				
Lobby flooring	5,000	SF	35.00	175,000
Core circulation - allow carpet	70,530	SF	6.00	423,180
Residential				
Livingrooms - allow wood	141,050	SF	22.00	3,103,100
Bedrooms - allow carpet	164,565	SF	6.00	987,390
Kitchen - allow stone tile	42,315	SF	25.00	1,057,875
Bathrooms - allow ceramic tile	47,020	SF	20.00	940,400
Special use areas	6,236	SF	10.00	62,360
Concrete sealer at basement	207,024	SF	2.00	414,048
Walls				
Lobby	1	EA	75,000.00	75,000
Core circulation	141,060	SF	3.00	423,180
Residential				
Livingrooms	282,100	SF	2.00	564,200
Bedrooms	329,130	SF	1.00	329,130
Kitchen	84,630	SF	10.00	846,300
Bathrooms	94,040	SF	12.00	1,128,480
Special use areas	9,354	SF	12.00	112,248
Paint to concrete and CMU at basement	70,776	SF	1.00	70,776
Ceilings				
Lobby	5,000	SF	25.00	125,000
Core circulation	70,530	SF	12.00	846,360
Residential				
Livingrooms	141,050	SF	6.00	846,300
Bedrooms	164,565	SF	6.00	987,390
Kitchen	42,315	SF	6.00	253,890
Bathrooms	47,020	SF	6.00	282,120
Special use areas	6,236	SF	10.00	62,360
Paint to exposed structure at basement	207,024	SF	2.00	414,048
				14,530,135

8. Function Equipment & Specialties

Specialties				
Fire extinguisher cabinets	150	EA	450.00	67,500
Trash chute	1	EA	110,000.00	110,000
Parking Garage equipment	1	LS	25,000.00	25,000

<i>Item Description</i>	<i>Quantity</i>	<i>Unit</i>	<i>Rate</i>	<i>Total</i>
Built in Equipment				
Lobby/entry	1	LS	25,000.00	25,000
Core area	70,530	SF	0.75	52,898
Residential				
Livingrooms	141,050	SF	0.05	7,053
Bedrooms	164,565	SF	0.10	16,457
Bathrooms	47,020	SF	1.00	47,020
Kitchen	42,315	EA	6.00	253,890
Special use areas	6,236	SF	2.00	12,472
Residential appliances				
Kitchen appliances				
Refrigerator	310	EA	1,700.00	527,000
Range	310	EA	2,000.00	620,000
Range hood	310	EA	1,000.00	310,000
Double oven	310	EA	800.00	248,000
Dishwasher	310	EA	850.00	263,500
Microwave	310	EA	450.00	139,500
Washing machine	310	EA	1,200.00	372,000
Dryer - electric	310	EA	1,200.00	372,000
Window washing equipment	1	LS	450,000.00	450,000
				3,919,289

9. Stairs & Vertical Transportation

Stairs				
Regular stair flights	88	EA	22,000.00	1,936,000
Elevators				
Passenger Elevators, gearless traction	176	STOP	28,000.00	4,928,000
Freight Elevators, geared traction, 4 stop	8	STOP	32,000.00	256,000
				7,120,000

<i>Item Description</i>	<i>Quantity</i>	<i>Unit</i>	<i>Rate</i>	<i>Total</i>
10. Plumbing Systems				
Sanitary fixtures and connection piping				
Toilets	736	EA	1,600.00	1,177,600
Lavatories	736	EA	1,200.00	883,200
Tub/shower combo	580	EA	1,800.00	1,044,000
Showers	232	EA	350.00	81,200
Kitchen sinks	310	EA	1,700.00	527,000
Washing machine connection	310	EA	350.00	108,500
Hose bibbs	10	EA	500.00	5,000
Domestic water and distribution				
Cold Water Service				
Copper piping incl. fittings >2"	900	LF	50.00	45,000
Copper piping incl. fittings to 2"	58,280	LF	32.00	1,864,960
Hot Water Service				
Copper piping incl. fittings >2"	1,400	LF	50.00	70,000
Copper piping incl. fittings to 2"	65,040	LF	32.00	2,081,280
Insulation	66,440	LF	9.00	597,960
Valves				
Isolation valves to 3/4"	4,772	EA	65.00	310,180
Domestic Water Supply Equipment				
Hot water heating and circulation	310	EA	900.00	279,000
Sanitary waste				
Waste & vent pipework-above ground				
Cast Iron No Hub, >6"	900	LF	75.00	67,500
Cast Iron No Hub, to 3"	58,280	LF	32.00	1,864,960
Sanitary waste, vent and service piping				
Floor Drains	88	EA	1,000.00	88,000
Rain Water Drainage				
Pipe and Fittings	51,583	LF	35.00	1,805,422
Roof/Overflow Drains	86	EA	750.00	64,695
Gas distribution				
Copper piping incl. fittings to 2"	2,000	LF	25.00	50,000
				13,015,457

<i>Item Description</i>	<i>Quantity</i>	<i>Unit</i>	<i>Rate</i>	<i>Total</i>
11. Heating, Ventilation & Air Conditioning				
Heat generating systems				
Heating hot water boilers, high efficiency condensing: Core Area only	3,700	MBTH	25.00	92,500
Heating hot water pumps	2	EA	15,000.00	30,000
Cooling Generating Systems: Core Area only				
Cooling towers	500	TN	250.00	125,000
Chillers, 2 each	500	TN	450.00	225,000
Chilled water pumps	2	EA	10,000.00	20,000
Condenser water pumps	2	EA	5,000.00	10,000
Variable speed drives, vibration isolation, etc.	6	EA	12,000.00	72,000
Distribution systems: Core Area only				
Piping, fittings, valves and insulation				
Chilled water				
Chilled water pipework, fittings	1,400	LF	95.00	133,000
Valves and specialties	1	LS	75,000.00	75,000
Heating hot water				
Heating hot water pipework, fittings, including insulation				
6" - 4"	1,200	LF	85.00	102,000
< = 3"	4,000	LF	30.00	120,000
Valves and specialties	1	LS	25,000.00	25,000
Condenser water				
Condenser water pipework, fittings	1,200	LF	90.00	108,000
Valves and specialties	1	LS	25,000.00	25,000
Connections to Fan Coil Boxes	164	EA	350.00	57,236
Air handling equipment				
Dedicated outside air supply air handler	220,000	CFM	5.00	1,100,000
Individual unit packaged units	310	EA	6,000.00	1,860,000
Fan Coil Units				
Core/Shell	164	EA	1,250.00	204,415
Parking area	207	EA	1,250.00	258,750
Sound attenuation - duct mounted	220,000	CFM	0.25	55,000
Air distribution, return and exhaust				
Galvanized sheet metal ductwork	288,790	LB	8.00	2,310,320
Dryer exhaust duct	9,300	LF	6.00	55,800
Flexible ductwork	3,000	LF	6.00	18,000
Dampers, volume	100	EA	40.00	4,000
Dampers, smoke/fire	80	EA	1,200.00	96,000
Insulation/duct liner	100,000	SF	2.50	250,000

<i>Item Description</i>	<i>Quantity</i>	<i>Unit</i>	<i>Rate</i>	<i>Total</i>
Diffusers, registers and grilles				
Ceiling				
Core/Shell	818	EA	200.00	163,532
Tenant areas, 1 per 150 USF	2,633	EA	150.00	394,950
Parking area				
Terminal & Package Units				
Exhaust fans at toilet rooms	736	EA	350.00	257,600
Controls and instrumentation				
DDC Control system	288,790	SF	3.00	866,370
Test and balance				
Test and balance	288,790	SF	1.25	360,988
				9,475,461

12. Electrical Lighting, Power & Communication

Primary Service, Medium voltage				
Switchgear 13.8KV including (2) tie breakers, (2) feeder breakers, and customer metering	6,000	KVA	60.00	360,000
Transformer substation 13.8KV/110-208V, double-ended including secondary distribution	6,000	KVA	150.00	900,000
Distribution switchboards - 110-208V	18,600	AMP	25.00	465,000
Distribution panelboards - 208V	310	EA	1,500.00	465,000
Feeder conduit and wire - 600V	45,000	LF	80.00	3,600,000
Emergency and Uninterrupted Power				
Emergency Generator	1,500	KVA	350.00	525,000
Automatic transfer switch	1,500	AMP	45.00	67,500
Distribution panelboards	1,500	AMP	25.00	37,500
General Purpose Lighting				
Panelboards	46	EA	2,500.00	115,000
Lighting				
Core Area	81,766	SF	12.00	981,192
Tenant Area	394,950	SF	2.00	789,900
Parking area	207,024	SF	4.00	828,096

<i>Item Description</i>	<i>Quantity</i>	<i>Unit</i>	<i>Rate</i>	<i>Total</i>
Machine and Equipment Power				
Connections and switches including conduit and wire				
Elevators	16	EA	1,000.00	16,000
Cooling towers	2	EA	5,000.00	10,000
Chillers	2	EA	12,000.00	24,000
Pumps	6	EA	2,000.00	12,000
Miscellaneous connections	683,748	SF	0.75	512,811
User Convenience Power				
Panelboards	46	EA	2,500.00	115,000
Receptacles				
Core/Shell	81,766	SF	3.00	245,298
Tenant Area	394,950	SF	3.00	1,184,850
Parking area	207,024	SF	2.00	414,048
Communications				
Telephone and communications				
Core Area, panels and backbone only	1	LS	75,000.00	75,000
Tenant Units	310	EA	800.00	248,000
Security Systems				
Main Security System	683,748	SF	0.10	68,375
Tenant Units	310	EA	900.00	279,000
Fire Alarm Systems				
Main Fire Alarm Systems	683,748	SF	3.00	2,051,244
Other Electrical Systems				
Grounding Systems	683,748	SF	0.25	170,937
Lightning protection	1	LS	25,000.00	25,000
				14,585,751

13. Fire Protection Systems

Sprinkler and Standpipe Systems				
Fire Protection Sprinkler Systems	683,748	SF	4.00	2,734,992
Standpipe and Hose Systems	683,748	SF	1.00	683,748
Specialties and Other Systems				
Smoke Evacuation	1	LS	250,000.00	250,000
				3,668,740

<i>Item Description</i>	<i>Quantity</i>	<i>Unit</i>	<i>Rate</i>	<i>Total</i>
<u>14. Site Preparation & Building Demolition</u>				
Site Preparation	100,000	SF	15.00	1,500,000
				<hr/>
				1,500,000
<u>15. Site Paving, Structures & Landscaping</u>				
Site Development	48,244	SF	25.00	1,206,100
				<hr/>
				1,206,100
<u>16. Utilities on Site</u>				
Site Utilities	1	LS	500,000.00	500,000
				<hr/>
				500,000



**PROGRAM
COST MODEL**

for

**PEER Tall Buildings Study
Concrete Dual System Structural Option
Los Angeles, California**

March 8, 2010

CONTENTS

	Page Nos.
Overall Summary	1
Areas and Control Quantities	2
Code Based Component Summary	3
Performance Based Component Summary	15

OVERALL SUMMARY

	Gross Floor Area	\$ / SF	\$x1,000
Construction Cost (Including Design)			
Code Based	683,748 SF	347.36	237,508
Performance Based	683,748 SF	411.33	281,245
Performance Based Plus	683,748 SF	411.33	281,245
FF&E Cost			
Furniture & Fittings, (residential)	476,716 SF	20.00	9,534
Equipment, including computer systems	476,716 SF	7.00	3,337
Personal Property			
Personal Contents	476,716 SF	10.00	4,767
Cars in parking (Maximum count)	520 EA	25,000.00	13,000

Please refer to the Inclusions and Exclusions sections of this report

AREAS & CONTROL QUANTITIES

Areas

	SF	SF	SF
Enclosed Areas			
Basement Levels B1 - B4	207,024		
Ground Level	11,314		
Levels 2 - 42	463,874		
Penthouse	1,536		
SUBTOTAL, Enclosed Area		683,748	
Covered area			
SUBTOTAL, Covered Area @ ½ Value			
TOTAL GROSS FLOOR AREA			683,748

Control Quantities

			Ratio to Gross Area
Functional Units	310 Units		0.453
Number of stories (x1,000)	46 EA		0.067
Gross Area	683,748 SF		1.000
Enclosed Area	683,748 SF		1.000
Covered Area	0 SF		0.000
Footprint Area	51,756 SF		0.076
Volume	7,212,004 CF		10.548
Basement Volume	0 CF		0.000
Gross Wall Area	212,093 SF		0.310
Retaining Wall Area	38,220 SF		0.056
Finished Wall Area	135,600 SF		0.198
Windows or Glazing Area	20.93% 44,400 SF		0.065
Roof Area - Flat	51,756 SF		0.076
Roof Area - Sloping	0 SF		0.000
Roof Area - Total	51,756 SF		0.076
Roof Glazing Area	0 SF		0.000
Interior Partition Length	132,334 LF		0.194
Finished Area	683,748 SF		1.000
Elevators (x10,000)	6 EA		0.088
Plumbing Fixtures (x1,000)	2,914 EA		4.262
Electrical Load	6,000 KW		8.775

CODE BASED COMPONENT SUMMARY

Gross Area: 683,748 SF

		\$/SF	\$x1,000
1. Foundations		16.35	11,178
2. Vertical Structure		21.86	14,949
3. Floor & Roof Structures		39.07	26,717
4. Exterior Cladding		36.15	24,720
5. Roofing, Waterproofing & Skylights		3.98	2,721
<i>Shell (1-5)</i>		117.42	80,286
6. Interior Partitions, Doors & Glazing		24.75	16,922
7. Floor, Wall & Ceiling Finishes		21.23	14,515
<i>Interiors (6-7)</i>		45.98	31,437
8. Function Equipment & Specialties		5.73	3,919
9. Stairs & Vertical Transportation		10.41	7,120
<i>Equipment & Vertical Transportation (8-9)</i>		16.15	11,039
10 Plumbing Systems		19.04	13,015
11 Heating, Ventilating & Air Conditioning		13.86	9,475
12 Electric Lighting, Power & Communications		21.33	14,586
13 Fire Protection Systems		5.37	3,669
<i>Mechanical & Electrical (10-13)</i>		59.59	40,745
Total Building Construction (1-13)		239.13	163,508
14 Site Preparation & Demolition		2.19	1,500
15 Site Paving, Structures & Landscaping		1.76	1,206
16 Utilities on Site		0.73	500
Total Site Construction (14-16)		4.69	3,206
TOTAL BUILDING & SITE (1-16)		243.82	166,714
General Conditions	12.00%	29.26	20,006
Contractor's Overhead & Profit or Fee	6.00%	16.38	11,203
PLANNED CONSTRUCTION COST		March 2010	289.47
Design, Management and Inspection	20.00%	57.89	39,585
Escalation is excluded	0.00%	0.00	0
RECOMMENDED BUDGET		March 2010	347.36
			237,508

<i>Item Description</i>	<i>Quantity</i>	<i>Unit</i>	<i>Rate</i>	<i>Total</i>
1. Foundations				
Basement Excavation				
Excavation	99,173	CY	15.00	1,487,595
Shoring at perimeter	36,400	SF	50.00	1,820,000
Backfill with imported material	14,829	CY	35.00	519,015
Dispose off site	99,173	CY	20.00	1,983,460
Hazardous material remediation				Excluded
Foundations				
Reinforced concrete Mat foundation				
Excavation and disposal	10,278	CY	15.00	154,170
Forwork	5,240	SF	18.00	94,320
Reinforcing steel	1,469,135	LBS	1.15	1,689,505
Concrete, f'c= 6ksi	10,278	CY	325.00	3,340,350
Elevator pits	6	EA	15,000.00	90,000
				11,178,415
2. Vertical Structure				
Columns and pilasters				
Concrete columns - moment frames				
Formwork	100,415	SF	25.00	2,510,375
Reinforcing steel	1,311,700	LBS	1.25	1,639,625
Concrete				
f'c= 10ksi	288	CY	450.00	129,600
f'c= 8ksi	670	CY	350.00	234,500
f'c= 6ksi	350	CY	325.00	113,750
f'c= 5ksi	1,918	CY	225.00	431,550
Concrete columns - standard				
Forwork	36,277	SF	25.00	906,925
Reinforcing steel	343,701	LBS	1.25	429,626
Concrete, f'c= 8ksi	658	CY	350.00	230,300
Concrete retaining walls				
Concrete retaining wall				
Formwork to one side	38,220	SF	25.00	955,500
Reinforcing steel	252,252	LBS	1.25	315,315
Concrete, f'c= 5ksi	2,076	CY	225.00	467,100

<i>Item Description</i>	<i>Quantity</i>	<i>Unit</i>	<i>Rate</i>	<i>Total</i>
Concrete core walls				
Formwork to both sides	170,841	SF	25.00	4,271,025
Reinforcing steel	474,699	LBS	1.25	593,374
Concrete				
f'c= 6ksi	3,496	CY	325.00	1,136,200
f'c= 5ksi	2,598	CY	225.00	584,550
				14,949,315

3. Floor and Roof Structure

Floor at lowest level
 Slab on grade - See foundations (mat slab)

Suspended floors

10" thick reinforced concrete flat slab -
basement slabs

Formwork	155,268	SF	10.00	1,552,680
Reinforcing steel	768,577	LBS	1.25	960,721
Concrete, f'c= 5.5ksi	5,271	CY	225.00	1,185,975

8" thick post tensioned slabs

Formwork	463,874	SF	10.00	4,638,740
Reinforcing steel	1,122,575	LBS	1.25	1,403,219
Post tension tendons	459,236	LBS	2.00	918,472
Studrails at columns (9 studrais with 9 studs per rail)	1,476	LOC	4,000.00	5,904,000
Concrete, f'c= 5.5ksi	12,599	CY	225.00	2,834,775

Special moment resisting frame reinforced
concrete beam

Formwork	137,632	SF	15.00	2,064,480
Reinforcing steel	1,639,660	LBS	1.25	2,049,575
Concrete, f'c= 5ksi	4,948	CY	225.00	1,113,300

Ground level slab/roof

12" thick reinforced concrete flat slab -
ground level

Formwork	51,756	SF	10.00	517,560
Reinforcing steel	455,453	LBS	1.25	569,316
Concrete, f'c= 5.5ksi	2,109	CY	225.00	474,525

Special moment resisting frame reinforced
concrete beam

Formwork	3,128	SF	10.00	31,280
Reinforcing steel	35,754	LBS	1.25	44,693
Concrete, f'c= 5ksi	112	CY	225.00	25,200

<i>Item Description</i>	<i>Quantity</i>	<i>Unit</i>	<i>Rate</i>	<i>Total</i>
High roof				
10" thick reinforced concrete flat slab				
Formwork	12,850	SF	10.00	128,500
Reinforcing steel	70,675	LBS	1.25	88,344
Concrete, f'c= 5.5ksi	437	CY	225.00	98,325
Special moment resisting frame reinforced concrete beam				
Formwork	3,128	SF	15.00	46,920
Reinforcing steel	33,109	LBS	1.25	41,386
Concrete, f'c= 5ksi	112	CY	225.00	25,200
				26,717,186

4. Exterior Cladding

Wall framing, furring and insulation				
Exterior wall framing	182,947	SF	8.00	1,463,576
Furring to interior face of retaining wall	38,220	SF	4.00	152,880
Insulation and vapor barrier	173,820	SF	1.50	260,730
Applied exterior finishes				
Exterior wall finish - curtain wall with spandrel panels	135,600	SF	120.00	16,272,000
Parapets & edge detailing	560	LF	250.00	140,000
Interior finish to exterior walls				
Gypsum board, taped and sanded	173,820	SF	3.50	608,370
Windows, glazing and louvers				
Exterior wall finish - curtain wall with glazing	44,400	SF	120.00	5,328,000
Exterior doors, frames and hardware				
Glazed Doors & Entrances (allow revolving)	12	EA	35,000.00	420,000
Solid Exterior Doors	8	EA	3,000.00	24,000
Overhead Doors	2	EA	25,000.00	50,000
				24,719,556

<i>Item Description</i>	<i>Quantity</i>	<i>Unit</i>	<i>Rate</i>	<i>Total</i>
5. Roofing, Waterproofing & Skylights				
Waterproofing				
Waterproofing at slab on grade	51,756	SF	10.00	517,560
Waterproofing at retaining wall	38,220	SF	10.00	382,200
Waterproofing membrane under plaza	40,442	SF	15.00	606,630
Insulation				
Rigid insulation at roof	11,314	SF	6.00	67,884
Roofing				
Balconies & accessible roofs	40,442	SF	25.00	1,011,050
High roof	11,314	SF	12.00	135,768
				2,721,092

6. Interior Partitions, Doors & Glazing

Partition framing and cores				
CMU partitions at basement levels	1,656	LF	325.00	538,200
Core partitions	11,880	LF	90.00	1,069,200
Standard partitions	118,798	LF	72.00	8,553,456
Doors, frames & hardware				
Unit entrance doors	310	EA	2,250.00	697,500
Standard interior doors	2,680	EA	1,800.00	4,824,000
Closet doors at units - allow bi-fold	1,240	EA	1,000.00	1,240,000
				16,922,356

7. Floor, Wall & Ceiling Finishes

Floors including base				
Lobby flooring	5,000	SF	35.00	175,000
Core circulation - allow carpet	70,530	SF	6.00	423,180
Residential				
Livingrooms - allow wood	141,050	SF	22.00	3,103,100
Bedrooms - allow carpet	164,565	SF	6.00	987,390
Kitchen - allow stone tile	42,315	SF	25.00	1,057,875
Bathrooms - allow ceramic tile	47,020	SF	20.00	940,400
Special use areas	6,236	SF	10.00	62,360
Concrete sealer at basement	207,024	SF	2.00	414,048

<i>Item Description</i>	<i>Quantity</i>	<i>Unit</i>	<i>Rate</i>	<i>Total</i>
Walls				
Lobby	1	EA	75,000.00	75,000
Core circulation	141,060	SF	3.00	423,180
Residential				
Livingrooms	282,100	SF	2.00	564,200
Bedrooms	329,130	SF	1.00	329,130
Kitchen	84,630	SF	10.00	846,300
Bathrooms	94,040	SF	12.00	1,128,480
Special use areas	9,354	SF	12.00	112,248
Paint to concrete and CMU at basement	55,608	SF	1.00	55,608
Ceilings				
Lobby	5,000	SF	25.00	125,000
Core circulation	70,530	SF	12.00	846,360
Residential				
Livingrooms	141,050	SF	6.00	846,300
Bedrooms	164,565	SF	6.00	987,390
Kitchen	42,315	SF	6.00	253,890
Bathrooms	47,020	SF	6.00	282,120
Special use areas	6,236	SF	10.00	62,360
Paint to exposed structure at basement	207,024	SF	2.00	414,048
				14,514,967

8. Function Equipment & Specialties

Specialties				
Fire extinguisher cabinets	150	EA	450.00	67,500
Trash chute	1	EA	110,000.00	110,000
Parking Garage equipment	1	LS	25,000.00	25,000
Built in Equipment				
Lobby/entry	1	LS	25,000.00	25,000
Core area	70,530	SF	0.75	52,898
Residential				
Livingrooms	141,050	SF	0.05	7,053
Bedrooms	164,565	SF	0.10	16,457
Kitchens	42,315	EA	6.00	253,890
Bathrooms	47,020	SF	1.00	47,020
Special use areas	6,236	SF	2.00	12,472

<i>Item Description</i>	<i>Quantity</i>	<i>Unit</i>	<i>Rate</i>	<i>Total</i>
Residential appliances				
Kitchen appliances				
Refrigerator	310	EA	1,700.00	527,000
Range	310	EA	2,000.00	620,000
Range hood	310	EA	1,000.00	310,000
Double oven	310	EA	800.00	248,000
Dishwasher	310	EA	850.00	263,500
Microwave	310	EA	450.00	139,500
Washing machine	310	EA	1,200.00	372,000
Dryer - electric	310	EA	1,200.00	372,000
Window washing equipment	1	LS	450,000.00	450,000
				3,919,289

9. Stairs & Vertical Transportation

Stairs				
Regular stair flights	88	EA	22,000.00	1,936,000
Elevators				
Passenger Elevators, gearless traction	176	STOP	28,000.00	4,928,000
Freight Elevators, geared traction, 4 stop	8	STOP	32,000.00	256,000
				7,120,000

10. Plumbing Systems

Sanitary fixtures and connection piping				
Toilets	736	EA	1,600.00	1,177,600
Lavatories	736	EA	1,200.00	883,200
Tub/shower combo	580	EA	1,800.00	1,044,000
Showers	232	EA	350.00	81,200
Kitchen sinks	310	EA	1,700.00	527,000
Washing machine connection	310	EA	350.00	108,500
Hose bibbs	10	EA	500.00	5,000

<i>Item Description</i>	<i>Quantity</i>	<i>Unit</i>	<i>Rate</i>	<i>Total</i>
Domestic water and distribution				
Cold Water Service				
Copper piping incl. fittings >2"	900	LF	50.00	45,000
Copper piping incl. fittings to 2"	58,280	LF	32.00	1,864,960
Hot Water Service				
Copper piping incl. fittings >2"	1,400	LF	50.00	70,000
Copper piping incl. fittings to 2"	65,040	LF	32.00	2,081,280
Insulation	66,440	LF	9.00	597,960
Valves				
Isolation valves to 3/4"	4,772	EA	65.00	310,180
Domestic Water Supply Equipment				
Hot water heating and circulation	310	EA	900.00	279,000
Sanitary waste				
Waste & vent pipework-above ground				
Cast Iron No Hub, >6"	900	LF	75.00	67,500
Cast Iron No Hub, to 3"	58,280	LF	32.00	1,864,960
Sanitary waste, vent and service piping				
Floor Drains	88	EA	1,000.00	88,000
Rain Water Drainage				
Pipe and Fittings	51,583	LF	35.00	1,805,422
Roof/Overflow Drains	86	EA	750.00	64,695
Gas distribution				
Copper piping incl. fittings to 2"	2,000	LF	25.00	50,000
				13,015,457

11. Heating, Ventilation & Air Conditioning

Heat generating systems				
Heating hot water boilers, high efficiency condensing: Core Area only				
	3,700	MBTH	25.00	92,500
Heating hot water pumps				
	2	EA	15,000.00	30,000
Cooling Generating Systems: Core Area only				
Cooling towers				
	500	TN	250.00	125,000
Chillers, 2 each				
	500	TN	450.00	225,000
Chilled water pumps				
	2	EA	10,000.00	20,000
Condenser water pumps				
	2	EA	5,000.00	10,000
Variable speed drives, vibration isolation, etc.				
	6	EA	12,000.00	72,000

<i>Item Description</i>	<i>Quantity</i>	<i>Unit</i>	<i>Rate</i>	<i>Total</i>
Distribution systems: Core Area only				
Piping, fittings, valves and insulation				
Chilled water				
Chilled water pipework, fittings	1,400	LF	95.00	133,000
Valves and specialties	1	LS	75,000.00	75,000
Heating hot water				
Heating hot water pipework, fittings, including insulation				
6" - 4"	1,200	LF	85.00	102,000
< = 3"	4,000	LF	30.00	120,000
Valves and specialties	1	LS	25,000.00	25,000
Condenser water				
Condenser water pipework, fittings	1,200	LF	90.00	108,000
Valves and specialties	1	LS	25,000.00	25,000
Connections to Fan Coil Boxes	164	EA	350.00	57,236
Air handling equipment				
Dedicated outside air supply air handler	220,000	CFM	5.00	1,100,000
Individual unit packaged units	310	EA	6,000.00	1,860,000
Fan Coil Units				
Core/Shell	164	EA	1,250.00	204,415
Parking area	207	EA	1,250.00	258,750
Sound attenuation - duct mounted	220,000	CFM	0.25	55,000
Air distribution, return and exhaust				
Galvanized sheet metal ductwork	288,790	LB	8.00	2,310,320
Dryer exhaust duct	9,300	LF	6.00	55,800
Flexible ductwork	3,000	LF	6.00	18,000
Dampers, volume	100	EA	40.00	4,000
Dampers, smoke/fire	80	EA	1,200.00	96,000
Insulation/duct liner	100,000	SF	2.50	250,000
Diffusers, registers and grilles				
Ceiling				
Core/Shell	818	EA	200.00	163,532
Tenant areas, 1 per 150 USF	2,633	EA	150.00	394,950
Parking area				
Terminal & Package Units				
Exhaust fans at toilet rooms	736	EA	350.00	257,600
Controls and instrumentation				
DDC Control system	288,790	SF	3.00	866,370

Item Description	Quantity	Unit	Rate	Total
Test and balance				
Test and balance	288,790	SF	1.25	360,988
				9,475,461

12. Electrical Lighting, Power & Communication

Primary Service, Medium voltage				
Switchgear 13.8KV including (2) tie breakers, (2) feeder breakers, and customer metering	6,000	KVA	60.00	360,000
Transformer substation 13.8KV/110-208V, double-ended including secondary distribution	6,000	KVA	150.00	900,000
Distribution switchboards - 110-208V	18,600	AMP	25.00	465,000
Distribution panelboards - 208V	310	EA	1,500.00	465,000
Feeder conduit and wire - 600V	45,000	LF	80.00	3,600,000
Emergency and Uninterrupted Power				
Emergency Generator	1,500	KVA	350.00	525,000
Automatic transfer switch	1,500	AMP	45.00	67,500
Distribution panelboards	1,500	AMP	25.00	37,500
General Purpose Lighting				
Panelboards	46	EA	2,500.00	115,000
Lighting				
Core Area	81,766	SF	12.00	981,192
Tenant Area	394,950	SF	2.00	789,900
Parking area	207,024	SF	4.00	828,096
Machine and Equipment Power				
Connections and switches including conduit and wire				
Elevators	16	EA	1,000.00	16,000
Cooling towers	2	EA	5,000.00	10,000
Chillers	2	EA	12,000.00	24,000
Pumps	6	EA	2,000.00	12,000
Miscellaneous connections	683,748	SF	0.75	512,811
User Convenience Power				
Panelboards	46	EA	2,500.00	115,000
Receptacles				
Core/Shell	81,766	SF	3.00	245,298
Tenant Area	394,950	SF	3.00	1,184,850
Parking area	207,024	SF	2.00	414,048

<i>Item Description</i>	<i>Quantity</i>	<i>Unit</i>	<i>Rate</i>	<i>Total</i>
Communications				
Telephone and communications				
Core Area, panels and backbone only	1	LS	75,000.00	75,000
Tenant Units	310	EA	800.00	248,000
Security Systems				
Main Security System	683,748	SF	0.10	68,375
Tenant Units	310	EA	900.00	279,000
Fire Alarm Systems				
Main Fire Alarm Systems	683,748	SF	3.00	2,051,244
Other Electrical Systems				
Grounding Systems	683,748	SF	0.25	170,937
Lightning protection	1	LS	25,000.00	25,000
				14,585,751

13. Fire Protection Systems

Sprinkler and Standpipe Systems				
Fire Protection Sprinkler Systems	683,748	SF	4.00	2,734,992
Standpipe and Hose Systems	683,748	SF	1.00	683,748
Specialties and Other Systems				
Smoke Evacuation	1	LS	250,000.00	250,000
				3,668,740

14. Site Preparation & Building Demolition

Site Preparation	100,000	SF	15.00	1,500,000
				1,500,000

15. Site Paving, Structures & Landscaping

Site Development	48,244	SF	25.00	1,206,100
				1,206,100

<i>Item Description</i>	<i>Quantity</i>	<i>Unit</i>	<i>Rate</i>	<i>Total</i>
16. Utilities on Site				
Site Utilities	1	LS	500,000.00	500,000
				<hr/> 500,000

PERFORMANCE BASED COMPONENT SUMMARY

		Gross Area: 683,748 SF	
		\$/SF	\$x1,000
1.	Foundations	16.35	11,178
2.	Vertical Structure	22.08	15,097
3.	Floor & Roof Structures	83.76	57,271
4.	Exterior Cladding	36.15	24,720
5.	Roofing, Waterproofing & Skylights	3.98	2,721
Shell (1-5)		162.32	110,987
6.	Interior Partitions, Doors & Glazing	24.75	16,922
7.	Floor, Wall & Ceiling Finishes	21.23	14,515
Interiors (6-7)		45.98	31,437
8.	Function Equipment & Specialties	5.73	3,919
9.	Stairs & Vertical Transportation	10.41	7,120
Equipment & Vertical Transportation (8-9)		16.15	11,039
10.	Plumbing Systems	19.04	13,015
11.	Heating, Ventilating & Air Conditioning	13.86	9,475
12.	Electric Lighting, Power & Communications	21.33	14,586
13.	Fire Protection Systems	5.37	3,669
Mechanical & Electrical (10-13)		59.59	40,745
Total Building Construction (1-13)		284.04	194,209
14.	Site Preparation & Demolition	2.19	1,500
15.	Site Paving, Structures & Landscaping	1.76	1,206
16.	Utilities on Site	0.73	500
Total Site Construction (14-16)		4.69	3,206
TOTAL BUILDING & SITE (1-16)		288.73	197,415
	General Conditions	12.00%	34.65
	Contractor's Overhead & Profit or Fee	6.00%	19.40
PLANNED CONSTRUCTION COST		March 2010	342.77
	Design, Management and Inspection	20.00%	68.55
	Escalation is excluded	0.00%	0
RECOMMENDED BUDGET		March 2010	411.33

<i>Item Description</i>	<i>Quantity</i>	<i>Unit</i>	<i>Rate</i>	<i>Total</i>
1. Foundations				
Basement Excavation				
Excavation	99,173	CY	15.00	1,487,595
Shoring at perimeter	36,400	SF	50.00	1,820,000
Backfill with imported material	14,829	CY	35.00	519,015
Dispose off site	99,173	CY	20.00	1,983,460
Hazardous material remediation				Excluded
Foundations				
Reinforced concrete Mat foundation				
Excavation and disposal	10,278	CY	15.00	154,170
Forwork	5,240	SF	18.00	94,320
Reinforcing steel	1,469,135	LBS	1.15	1,689,505
Concrete, f'c= 6ksi	10,278	CY	325.00	3,340,350
Elevator pits	6	EA	15,000.00	90,000
				11,178,415
2. Vertical Structure				
Columns and pilasters				
Concrete columns - moment frames				
Formwork	100,247	SF	25.00	2,506,175
Reinforcing steel	1,315,178	LBS	1.25	1,643,973
Concrete				
f'c= 10ksi	371	CY	450.00	166,950
f'c= 8ksi	890	CY	350.00	311,500
f'c= 6ksi	318	CY	325.00	103,350
f'c= 5ksi	1,535	CY	225.00	345,375
Concrete columns - standard				
Forwork	36,277	SF	25.00	906,925
Reinforcing steel	343,701	LBS	1.25	429,626
Concrete, f'c= 8ksi	658	CY	350.00	230,300
Concrete retaining walls				
Concrete retaining wall				
Formwork to one side	38,220	SF	25.00	955,500
Reinforcing steel	252,252	LBS	1.25	315,315
Concrete, f'c= 5ksi	2,076	CY	225.00	467,100

<i>Item Description</i>	<i>Quantity</i>	<i>Unit</i>	<i>Rate</i>	<i>Total</i>
Concrete core walls				
Formwork to both sides	170,841	SF	25.00	4,271,025
Reinforcing steel	447,823	LBS	1.25	559,779
Concrete				
f'c= 8ksi	3,496	CY	350.00	1,223,600
f'c= 6ksi	1,125	CY	325.00	365,625
f'c= 5ksi	1,310	CY	225.00	294,750
				15,096,868

3. Floor and Roof Structure

Floor at lowest level
 Slab on grade - See foundations (mat slab)

Suspended floors

10" thick reinforced concrete flat slab -
 basement slabs

Formwork	155,268	SF	10.00	1,552,680
Reinforcing steel	768,577	LBS	1.25	960,721
Concrete, f'c= 5.5ksi	142,329	CY	225.00	32,024,025

8" thick post tensioned slabs

Formwork	463,874	SF	10.00	4,638,740
Reinforcing steel	1,122,575	LBS	1.25	1,403,219
Post tension tendons	459,236	LBS	2.00	918,472
Studrails at columns (9 studrais with 9 studs per rail)	1,476	LOC	4,000.00	5,904,000
Concrete, f'c= 5.5ksi	12,599	CY	225.00	2,834,775

Special moment resisting frame reinforced
 concrete beam

Formwork	137,632	SF	15.00	2,064,480
Reinforcing steel	1,420,802	LBS	1.25	1,776,003
Concrete, f'c= 5ksi	4,948	CY	225.00	1,113,300

Ground level slab/roof

12" thick reinforced concrete flat slab -
 ground level

Formwork	51,756	SF	10.00	517,560
Reinforcing steel	455,453	LBS	1.25	569,316
Concrete, f'c= 5.5ksi	2,109	CY	225.00	474,525

Special moment resisting frame reinforced
 concrete beam

Formwork	3,128	SF	10.00	31,280
Reinforcing steel	30,635	LBS	1.25	38,294
Concrete, f'c= 5ksi	112	CY	225.00	25,200

<i>Item Description</i>	<i>Quantity</i>	<i>Unit</i>	<i>Rate</i>	<i>Total</i>
High roof				
10" thick reinforced concrete flat slab				
Formwork	12,850	SF	10.00	128,500
Reinforcing steel	70,675	LBS	1.25	88,344
Concrete, f'c= 5.5ksi	437	CY	225.00	98,325
Special moment resisting frame reinforced concrete beam				
Formwork	3,128	SF	15.00	46,920
Reinforcing steel	29,994	LBS	1.25	37,493
Concrete, f'c= 5ksi	112	CY	225.00	25,200
				57,271,371

4. Exterior Cladding

Wall framing, furring and insulation				
Exterior wall framing	182,947	SF	8.00	1,463,576
Furring to interior face of retaining wall	38,220	SF	4.00	152,880
Insulation and vapor barrier	173,820	SF	1.50	260,730
Applied exterior finishes				
Exterior wall finish - curtain wall with spandrel panels	135,600	SF	120.00	16,272,000
Parapets & edge detailing	560	LF	250.00	140,000
Interior finish to exterior walls				
Gypsum board, taped and sanded	173,820	SF	3.50	608,370
Windows, glazing and louvers				
Exterior wall finish - curtain wall with glazing	44,400	SF	120.00	5,328,000
Exterior doors, frames and hardware				
Glazed Doors & Entrances (allow revolving)	12	EA	35,000.00	420,000
Solid Exterior Doors	8	EA	3,000.00	24,000
Overhead Doors	2	EA	25,000.00	50,000
				24,719,556

<i>Item Description</i>	<i>Quantity</i>	<i>Unit</i>	<i>Rate</i>	<i>Total</i>
5. Roofing, Waterproofing & Skylights				
Waterproofing				
Waterproofing at slab on grade	51,756	SF	10.00	517,560
Waterproofing at retaining wall	38,220	SF	10.00	382,200
Waterproofing membrane under plaza	40,442	SF	15.00	606,630
Insulation				
Rigid insulation at roof	11,314	SF	6.00	67,884
Roofing				
Balconies & accessible roofs	40,442	SF	25.00	1,011,050
High roof	11,314	SF	12.00	135,768
				2,721,092

6. Interior Partitions, Doors & Glazing

Partition framing and cores				
CMU partitions at basement levels	1,656	LF	325.00	538,200
Core partitions	11,880	LF	90.00	1,069,200
Standard partitions	118,798	LF	72.00	8,553,456
Doors, frames & hardware				
Unit entrance doors	310	EA	2,250.00	697,500
Standard interior doors	2,680	EA	1,800.00	4,824,000
Closet doors at units - allow bi-fold	1,240	EA	1,000.00	1,240,000
				16,922,356

7. Floor, Wall & Ceiling Finishes

Floors including base				
Lobby flooring	5,000	SF	35.00	175,000
Core circulation - allow carpet	70,530	SF	6.00	423,180
Residential				
Livingrooms - allow wood	141,050	SF	22.00	3,103,100
Bedrooms - allow carpet	164,565	SF	6.00	987,390
Kitchen - allow stone tile	42,315	SF	25.00	1,057,875
Bathrooms - allow ceramic tile	47,020	SF	20.00	940,400
Special use areas	6,236	SF	10.00	62,360
Concrete sealer at basement	207,024	SF	2.00	414,048

<i>Item Description</i>	<i>Quantity</i>	<i>Unit</i>	<i>Rate</i>	<i>Total</i>
Walls				
Lobby	1	EA	75,000.00	75,000
Core circulation	141,060	SF	3.00	423,180
Residential				
Livingrooms	282,100	SF	2.00	564,200
Bedrooms	329,130	SF	1.00	329,130
Kitchen	84,630	SF	10.00	846,300
Bathrooms	94,040	SF	12.00	1,128,480
Special use areas	9,354	SF	12.00	112,248
Paint to concrete and CMU at basement	55,608	SF	1.00	55,608
Ceilings				
Lobby	5,000	SF	25.00	125,000
Core circulation	70,530	SF	12.00	846,360
Residential				
Livingrooms	141,050	SF	6.00	846,300
Bedrooms	164,565	SF	6.00	987,390
Kitchen	42,315	SF	6.00	253,890
Bathrooms	47,020	SF	6.00	282,120
Special use areas	6,236	SF	10.00	62,360
Paint to exposed structure at basement	207,024	SF	2.00	414,048
				14,514,967

8. Function Equipment & Specialties

Specialties				
Fire extinguisher cabinets	150	EA	450.00	67,500
Trash chute	1	EA	110,000.00	110,000
Parking Garage equipment	1	LS	25,000.00	25,000
Built in Equipment				
Lobby/entry	1	LS	25,000.00	25,000
Core area	70,530	SF	0.75	52,898
Residential				
Livingrooms	141,050	SF	0.05	7,053
Bedrooms	164,565	SF	0.10	16,457
Kitchens	42,315	EA	6.00	253,890
Bathrooms	47,020	SF	1.00	47,020
Special use areas	6,236	SF	2.00	12,472

<i>Item Description</i>	<i>Quantity</i>	<i>Unit</i>	<i>Rate</i>	<i>Total</i>
Residential appliances				
Kitchen appliances				
Refrigerator	310	EA	1,700.00	527,000
Range	310	EA	2,000.00	620,000
Range hood	310	EA	1,000.00	310,000
Double oven	310	EA	800.00	248,000
Dishwasher	310	EA	850.00	263,500
Microwave	310	EA	450.00	139,500
Washing machine	310	EA	1,200.00	372,000
Dryer - electric	310	EA	1,200.00	372,000
Window washing equipment	1	LS	450,000.00	450,000
				3,919,289

9. Stairs & Vertical Transportation

Stairs				
Regular stair flights	88	EA	22,000.00	1,936,000
Elevators				
Passenger Elevators, gearless traction	176	STOP	28,000.00	4,928,000
Freight Elevators, geared traction, 4 stop	8	STOP	32,000.00	256,000
				7,120,000

10. Plumbing Systems

Sanitary fixtures and connection piping				
Toilets	736	EA	1,600.00	1,177,600
Lavatories	736	EA	1,200.00	883,200
Tub/shower combo	580	EA	1,800.00	1,044,000
Showers	232	EA	350.00	81,200
Kitchen sinks	310	EA	1,700.00	527,000
Washing machine connection	310	EA	350.00	108,500
Hose bibbs	10	EA	500.00	5,000

<i>Item Description</i>	<i>Quantity</i>	<i>Unit</i>	<i>Rate</i>	<i>Total</i>
Domestic water and distribution				
Cold Water Service				
Copper piping incl. fittings >2"	900	LF	50.00	45,000
Copper piping incl. fittings to 2"	58,280	LF	32.00	1,864,960
Hot Water Service				
Copper piping incl. fittings >2"	1,400	LF	50.00	70,000
Copper piping incl. fittings to 2"	65,040	LF	32.00	2,081,280
Insulation	66,440	LF	9.00	597,960
Valves				
Isolation valves to 3/4"	4,772	EA	65.00	310,180
Domestic Water Supply Equipment				
Hot water heating and circulation	310	EA	900.00	279,000
Sanitary waste				
Waste & vent pipework-above ground				
Cast Iron No Hub, >6"	900	LF	75.00	67,500
Cast Iron No Hub, to 3"	58,280	LF	32.00	1,864,960
Sanitary waste, vent and service piping				
Floor Drains	88	EA	1,000.00	88,000
Rain Water Drainage				
Pipe and Fittings	51,583	LF	35.00	1,805,422
Roof/Overflow Drains	86	EA	750.00	64,695
Gas distribution				
Copper piping incl. fittings to 2"	2,000	LF	25.00	50,000
				13,015,457

11. Heating, Ventilation & Air Conditioning

Heat generating systems				
Heating hot water boilers, high efficiency condensing: Core Area only				
	3,700	MBTH	25.00	92,500
Heating hot water pumps				
	2	EA	15,000.00	30,000
Cooling Generating Systems: Core Area only				
Cooling towers				
	500	TN	250.00	125,000
Chillers, 2 each				
	500	TN	450.00	225,000
Chilled water pumps				
	2	EA	10,000.00	20,000
Condenser water pumps				
	2	EA	5,000.00	10,000
Variable speed drives, vibration isolation, etc.				
	6	EA	12,000.00	72,000

<i>Item Description</i>	<i>Quantity</i>	<i>Unit</i>	<i>Rate</i>	<i>Total</i>
Distribution systems: Core Area only				
Piping, fittings, valves and insulation				
Chilled water				
Chilled water pipework, fittings	1,400	LF	95.00	133,000
Valves and specialties	1	LS	75,000.00	75,000
Heating hot water				
Heating hot water pipework, fittings, including insulation				
6" - 4"	1,200	LF	85.00	102,000
< = 3"	4,000	LF	30.00	120,000
Valves and specialties	1	LS	25,000.00	25,000
Condenser water				
Condenser water pipework, fittings	1,200	LF	90.00	108,000
Valves and specialties	1	LS	25,000.00	25,000
Connections to Fan Coil Boxes	164	EA	350.00	57,236
Air handling equipment				
Dedicated outside air supply air handler	220,000	CFM	5.00	1,100,000
Individual unit packaged units	310	EA	6,000.00	1,860,000
Fan Coil Units				
Core/Shell	164	EA	1,250.00	204,415
Parking area	207	EA	1,250.00	258,750
Sound attenuation - duct mounted	220,000	CFM	0.25	55,000
Air distribution, return and exhaust				
Galvanized sheet metal ductwork	288,790	LB	8.00	2,310,320
Dryer exhaust duct	9,300	LF	6.00	55,800
Flexible ductwork	3,000	LF	6.00	18,000
Dampers, volume	100	EA	40.00	4,000
Dampers, smoke/fire	80	EA	1,200.00	96,000
Insulation/duct liner	100,000	SF	2.50	250,000
Diffusers, registers and grilles				
Ceiling				
Core/Shell	818	EA	200.00	163,532
Tenant areas, 1 per 150 USF	2,633	EA	150.00	394,950
Parking area				
Terminal & Package Units				
Exhaust fans at toilet rooms	736	EA	350.00	257,600
Controls and instrumentation				
DDC Control system	288,790	SF	3.00	866,370

<i>Item Description</i>	<i>Quantity</i>	<i>Unit</i>	<i>Rate</i>	<i>Total</i>
Test and balance Test and balance	288,790	SF	1.25	360,988
				9,475,461

12. Electrical Lighting, Power & Communication

Primary Service, Medium voltage				
Switchgear 13.8KV including (2) tie breakers, (2) feeder breakers, and customer metering	6,000	KVA	60.00	360,000
Transformer substation 13.8KV/110-208V, double-ended including secondary distribution	6,000	KVA	150.00	900,000
Distribution switchboards - 110-208V	18,600	AMP	25.00	465,000
Distribution panelboards - 208V	310	EA	1,500.00	465,000
Feeder conduit and wire - 600V	45,000	LF	80.00	3,600,000
Emergency and Uninterrupted Power				
Emergency Generator	1,500	KVA	350.00	525,000
Automatic transfer switch	1,500	AMP	45.00	67,500
Distribution panelboards	1,500	AMP	25.00	37,500
General Purpose Lighting				
Panelboards	46	EA	2,500.00	115,000
Lighting				
Core Area	81,766	SF	12.00	981,192
Tenant Area	394,950	SF	2.00	789,900
Parking area	207,024	SF	4.00	828,096
Machine and Equipment Power				
Connections and switches including conduit and wire				
Elevators	16	EA	1,000.00	16,000
Cooling towers	2	EA	5,000.00	10,000
Chillers	2	EA	12,000.00	24,000
Pumps	6	EA	2,000.00	12,000
Miscellaneous connections	683,748	SF	0.75	512,811
User Convenience Power				
Panelboards	46	EA	2,500.00	115,000
Receptacles				
Core/Shell	81,766	SF	3.00	245,298
Tenant Area	394,950	SF	3.00	1,184,850
Parking area	207,024	SF	2.00	414,048

<i>Item Description</i>	<i>Quantity</i>	<i>Unit</i>	<i>Rate</i>	<i>Total</i>
Communications				
Telephone and communications				
Core Area, panels and backbone only	1	LS	75,000.00	75,000
Tenant Units	310	EA	800.00	248,000
Security Systems				
Main Security System	683,748	SF	0.10	68,375
Tenant Units	310	EA	900.00	279,000
Fire Alarm Systems				
Main Fire Alarm Systems	683,748	SF	3.00	2,051,244
Other Electrical Systems				
Grounding Systems	683,748	SF	0.25	170,937
Lightning protection	1	LS	25,000.00	25,000
				14,585,751

13. Fire Protection Systems

Sprinkler and Standpipe Systems				
Fire Protection Sprinkler Systems	683,748	SF	4.00	2,734,992
Standpipe and Hose Systems	683,748	SF	1.00	683,748
Specialties and Other Systems				
Smoke Evacuation	1	LS	250,000.00	250,000
				3,668,740

14. Site Preparation & Building Demolition

Site Preparation	100,000	SF	15.00	1,500,000
				1,500,000

15. Site Paving, Structures & Landscaping

Site Development	48,244	SF	25.00	1,206,100
				1,206,100

<i>Item Description</i>	<i>Quantity</i>	<i>Unit</i>	<i>Rate</i>	<i>Total</i>
16. Utilities on Site				
Site Utilities	1	LS	500,000.00	500,000
				<hr/> 500,000



**PROGRAM
COST MODEL**

for

**PEER Tall Buildings Study
Steel Structural Option
Los Angeles, California**

March 8, 2010

CONTENTS

	Page Nos.
Overall Summary	1
Areas and Control Quantities	2
Code Based Component Summary	3
Performance Based Component Summary	13
Performance Based Plus Component Summary	23

OVERALL SUMMARY

	Gross Floor Area	\$ / SF	\$x1,000
Construction Cost (Including Design)			
Code Based	959,110 SF	369.76	354,636
Performance Based	959,110 SF	354.02	339,546
Performance Based Plus	959,110 SF	359.97	345,251
FF&E Cost			
Furniture & Fittings, including system furniture	763,350 SF	50.00	38,168
Equipment, including computer systems	763,350 SF	35.00	26,717
Personal Property			
Personal Contents	763,350 SF	2.00	1,527
Cars in parking (Maximum count)	490 EA	25,000.00	12,250

Please refer to the Inclusions and Exclusions sections of this report

AREAS & CONTROL QUANTITIES

Areas

	SF	SF	SF
Enclosed Areas			
Basement Levels B1 - B4	199,760		
Ground Level	49,940		
Levels 1 - 10	181,900		
Levels 11 - 39	527,510		
SUBTOTAL, Enclosed Area		959,110	
Covered area			
SUBTOTAL, Covered Area @ ½ Value			
TOTAL GROSS FLOOR AREA			959,110

Control Quantities

			Ratio to Gross Area
Number of stories (x1,000)	44	EA	0.046
Gross Area	959,110	SF	1.000
Enclosed Area	959,110	SF	1.000
Covered Area	0	SF	0.000
Footprint Area	49,940	SF	0.052
Volume	12,301,575	CF	12.826
Basement Volume	2,397,120	CF	2.499
Gross Wall Area	344,565	SF	0.359
Retaining Wall Area	42,912	SF	0.045
Finished Wall Area	301,653	SF	0.315
Windows or Glazing Area	21.89% 75,414	SF	0.079
Roof Area - Flat	49,940	SF	0.052
Roof Area - Sloping	0	SF	0.000
Roof Area - Total	49,940	SF	0.052
Roof Glazing Area	0	SF	0.000
Interior Partition Length	58,608	LF	0.061
Finished Area	959,110	SF	1.000
Elevators (x10,000)	6	EA	0.063
Plumbing Fixtures (x1,000)	924	EA	0.963
Electrical Load	12,000	KW	12.512

CODE BASED COMPONENT SUMMARY

Gross Area: 959,110 SF

		\$/SF	\$x1,000
1. Foundations		19.53	18,730
2. Vertical Structure		57.00	54,668
3. Floor & Roof Structures		26.34	25,262
4. Exterior Cladding		42.43	40,697
5. Roofing, Waterproofing & Skylights		2.63	2,526
<i>Shell (1-5)</i>		147.93	141,884
6. Interior Partitions, Doors & Glazing		10.18	9,760
7. Floor, Wall & Ceiling Finishes		13.93	13,358
<i>Interiors (6-7)</i>		24.10	23,119
8. Function Equipment & Specialties		9.87	9,471
9. Stairs & Vertical Transportation		9.99	9,584
<i>Equipment & Vertical Transportation (8-9)</i>		19.87	19,055
10 Plumbing Systems		6.12	5,872
11 Heating, Ventilating & Air Conditioning		29.23	28,033
12 Electric Lighting, Power & Communications		23.64	22,670
13 Fire Protection Systems		5.26	5,046
<i>Mechanical & Electrical (10-13)</i>		64.25	61,621
Total Building Construction (1-13)		256.15	245,679
14 Site Preparation & Demolition		1.56	1,500
15 Site Paving, Structures & Landscaping		1.30	1,252
16 Utilities on Site		0.52	500
Total Site Construction (14-16)		3.39	3,252
TOTAL BUILDING & SITE (1-16)		259.54	248,930
General Conditions	12.00%	31.15	29,872
Contractor's Overhead & Profit or Fee	6.00%	17.44	16,728
PLANNED CONSTRUCTION COST		March 2010	308.13
Design, Management and Inspection	20.00%	61.63	59,106
Escalation is excluded	0.00%	0.00	0
RECOMMENDED BUDGET		March 2010	369.76

<i>Item Description</i>	<i>Quantity</i>	<i>Unit</i>	<i>Rate</i>	<i>Total</i>
1. Foundations				
Mass excavation				
Excavate for basement and mat foundation	140,778	CY	15.00	2,111,670
Shoring at perimeter	53,640	SF	50.00	2,682,000
Backfill with imported material	29,802	CY	35.00	1,043,070
Dispose off site	140,778	CY	20.00	2,815,560
Hazardous material remediation				Excluded
Foundations				
Reinforced concrete mat foundation, 12'-0"	49,940	SF	200.00	9,988,000
Elevator pits	6	EA	15,000.00	90,000
				18,730,300
2. Vertical Structure				
Columns and pilasters				
Wide flange	880	TN	4,000.00	3,520,000
Box columns				
Metal plate frame	5,436	TN	6,000.00	32,616,000
Studs- 3/4" diameter, 6" long	101,088	EA	60.00	6,065,280
Concrete fill	3,101	CY	450.00	1,395,450
Sprayed fireproofing	880	TN	350.00	308,000
Diagonal reinforcing				
Buckling restraint braces				
1026 k	1,368	LF	300.00	410,400
950 k	1,260	LF	225.00	283,500
703 k	902	LF	180.00	162,360
589 k	7,326	LF	150.00	1,098,900
532 k	912	LF	150.00	136,800
513 k	6,516	LF	150.00	977,400
418 k	608	LF	120.00	72,960
380 k	960	LF	120.00	115,200
342 k	836	LF	120.00	100,320
304 k	720	LF	120.00	86,400
266 k	1,252	LF	100.00	125,200
228 k	380	LF	100.00	38,000
Brace connections				
Gusset plates				
3/4" thick plate steel welded connection	168	EA	1,500.00	252,000
1" thick plate steel welded connection	1,916	EA	2,000.00	3,832,000
2" thick plate steel welded connection	232	EA	4,000.00	928,000

<i>Item Description</i>	<i>Quantity</i>	<i>Unit</i>	<i>Rate</i>	<i>Total</i>
Concrete retaining walls				
18" Concrete retaining wall				
Formwork to one side	21,456	SF	15.00	321,840
Reinforcing steel	283,824	LBS	1.15	326,398
Concrete	1,311	CY	225.00	294,975
24" Concrete retaining wall				
Formwork to one side	21,456	SF	15.00	321,840
Reinforcing steel	422,059	LBS	1.15	485,368
Concrete	1,748	CY	225.00	393,300
				54,667,890

3. Floor and Roof Structure

Floor at lowest level				
Slab on grade - See foundations (mat slab)				
Suspended floors				
Wide flange framing	3,359	TN	4,000.00	13,436,000
Channel and angle ledger	101,965	LBS	2.50	254,913
3" formlock deck, 18 ga.	859,230	SF	4.50	3,866,535
3 1/4" lightweight concrete	859,230	SF	5.00	4,296,150
Sprayed fireproofing	3,359	TN	350.00	1,175,650
Plaza level slab/roof				
Wide flange framing	295	TN	4,000.00	1,180,000
Channel and angle ledger	33,988	LBS	2.50	84,970
3" formlock deck, 16 ga.	49,940	SF	4.50	224,730
9" normal weight concrete	49,940	SF	5.00	249,700
Sprayed fireproofing	295	TN	350.00	103,250
High roof				
Wide flange framing	50	TN	4,000.00	200,000
3" formlock deck, 18 ga.	18,190	SF	4.50	81,855
3 1/4" lightweight concrete	18,190	SF	5.00	90,950
Sprayed fireproofing	50	TN	350.00	17,500
				25,262,203

<i>Item Description</i>	<i>Quantity</i>	<i>Unit</i>	<i>Rate</i>	<i>Total</i>
4. Exterior Cladding				
Wall framing, furring and insulation				
Exterior wall framing	301,653	SF	8.00	2,413,224
Furring to interior face of retaining wall	42,912	SF	4.00	171,648
Insulation and vapor barrier	226,240	SF	1.50	339,360
Applied exterior finishes				
Exterior wall finish - curtain wall with spandrel panels	226,240	SF	120.00	27,148,800
Parapets & edge detailing	554	LF	250.00	138,500
Interior finish to exterior walls				
Gypsum board, taped and sanded	269,152	SF	3.50	942,032
Windows, glazing and louvers				
Exterior wall finish - curtain wall with glazing	75,414	SF	120.00	9,049,680
Exterior doors, frames and hardware				
Glazed Doors & Entrances (allow revolving)	12	EA	35,000.00	420,000
Solid Exterior Doors	8	EA	3,000.00	24,000
Overhead Doors	2	EA	25,000.00	50,000
				40,697,244
5. Roofing, Waterproofing & Skylights				
Waterproofing				
Waterproofing at slab on grade	49,940	SF	10.00	499,400
Waterproofing at retaining wall	42,912	SF	10.00	429,120
Waterproofing membrane under plaza	31,750	SF	15.00	476,250
Roof insulation				
Rigid insulation at roof	18,190	SF	6.00	109,140
Roofing				
Balconies & accessible roofs	31,750	SF	25.00	793,750
High roof	18,190	SF	12.00	218,280
				2,525,940

<i>Item Description</i>	<i>Quantity</i>	<i>Unit</i>	<i>Rate</i>	<i>Total</i>
6. Interior Partitions, Doors & Glazing				
Partition framing and cores				
CMU partitions at basement levels	400	LF	325.00	130,000
Core partitions	7,276	LF	90.00	654,840
Standard partitions	50,932	LF	72.00	3,667,104
Window walls and borrowed lights	1,020	SF	45.00	45,900
Doors, frames & hardware				
Interior doors	2,392	EA	2,200.00	5,262,400
				9,760,244
7. Floor, Wall & Ceiling Finishes				
Floors including base				
Lobby flooring	5,000	SF	35.00	175,000
Core circulation	88,000	SF	6.00	528,000
Restrooms	44,000	SF	15.00	660,000
Office	616,350	SF	5.00	3,081,750
Special use areas	10,000	SF	10.00	100,000
Concrete sealer at basement	195,760	SF	2.00	391,520
Walls				
Lobby	1	EA	75,000.00	75,000
Core circulation	176,000	SF	3.00	528,000
Restroom walls	79,200	SF	15.00	1,188,000
Office	739,620	SF	1.50	1,109,430
Special use areas	15,000	SF	5.00	75,000
Paint to concrete and CMU at basement	52,512	SF	1.00	52,512
Ceilings				
Lobby	5,000	SF	25.00	125,000
Core circulation	88,000	SF	12.00	1,056,000
Restrooms	44,000	SF	15.00	660,000
Office	616,350	SF	5.00	3,081,750
Special use areas	10,000	SF	8.00	80,000
Paint to exposed structure at basement	195,760	SF	2.00	391,520
				13,358,482

Item Description	Quantity	Unit	Rate	Total
------------------	----------	------	------	-------

8. Function Equipment & Specialties

Built in Equipment				
Lobby/entry	1	LS	25,000.00	25,000
Core area	40	EA	18,000.00	720,000
Office areas	616,350	SF	12.00	7,396,200
Restroom areas	44,000	SF	20.00	880,000
Window washing equipment	1	LS	450,000.00	450,000
				9,471,200

9. Stairs & Vertical Transportation

Stairs				
Regular stair flights	88	EA	22,000.00	1,936,000
Elevators				
Passenger Elevators, gearless traction	264	STOP	28,000.00	7,392,000
Freight Elevators, geared traction, 4 stop	8	STOP	32,000.00	256,000
				9,584,000

10. Plumbing Systems

Sanitary fixtures and connection piping				
Toilets	440	EA	1,600.00	704,000
Urinals	88	EA	1,800.00	158,400
Lavatories	264	EA	1,200.00	316,800
Drinking Fountains and Coolers	44	EA	2,500.00	110,000
Sinks	44	EA	1,700.00	74,800
Hose bibbs	44	EA	500.00	22,000
Domestic water and distribution				
Cold Water Service				
Copper piping incl. fittings >2"	1,300	LF	50.00	65,000
Copper piping incl. fittings to 2"	13,860	LF	32.00	443,520
Hot Water Service				
Copper piping incl. fittings >2"	2,600	LF	50.00	130,000
Copper piping incl. fittings to 2"	27,720	LF	32.00	887,040
Insulation	30,320	LF	9.00	272,880
Valves				
Isolation valves to 3/4"	1,232	EA	65.00	80,080
Domestic Water Supply Equipment				
Hot water heating and circulation	1	LS	200,000.00	200,000

<i>Item Description</i>	<i>Quantity</i>	<i>Unit</i>	<i>Rate</i>	<i>Total</i>
Sanitary waste				
Waste & vent pipework-above ground				
Cast Iron No Hub, >6"	1,300	LF	75.00	97,500
Cast Iron No Hub, to 3"	13,860	LF	32.00	443,520
Sanitary waste, vent and service piping				
Floor Drains	88	EA	1,000.00	88,000
Rain Water Drainage				
Pipe and Fittings	47,609	LF	35.00	1,666,331
Roof/Overflow Drains	83	EA	750.00	62,425
Gas distribution				
Copper piping incl. fittings to 2"	2,000	LF	25.00	50,000
				5,872,296

11. Heating, Ventilation & Air Conditioning

Heat generating systems				
Heating hot water boilers, high efficiency condensing	43,200	MBTH	25.00	1,080,000
Heating hot water pumps	2	EA	35,000.00	70,000
Cooling Generating Systems				
Cooling towers	3,000	TN	350.00	1,050,000
Chillers, 2 each	3,000	TN	550.00	1,650,000
Chilled water pumps	2	EA	30,000.00	60,000
Condenser water pumps	2	EA	28,000.00	56,000
Variable speed drives, vibration isolation, etc.	6	EA	12,000.00	72,000
Distribution systems				
Piping, fittings, valves and insulation				
Chilled water				
Chilled water pipework, fittings	1,400	LF	95.00	133,000
Valves and specialties	1	LS	75,000.00	75,000
Heating hot water				
Heating hot water pipework, fittings, including insulation				
6" - 4"	1,200	LF	85.00	102,000
< = 3"	36,000	LF	30.00	1,080,000
Valves and specialties	1	LS	150,000.00	150,000

<i>Item Description</i>	<i>Quantity</i>	<i>Unit</i>	<i>Rate</i>	<i>Total</i>
Condenser water				
Condenser water pipework, fittings	1,200	LF	90.00	108,000
Valves and specialties	1	LS	25,000.00	25,000
Connections to VAV boxes	1,517	EA	350.00	531,038
Air handling equipment				
Air handler units	700,000	CFM	5.00	3,500,000
VAV boxes				
Core/Shell	294	EA	1,250.00	367,500
Tenant areas, 1 per 600 USF	1,027	EA	1,250.00	1,284,063
Parking area	196	EA	1,250.00	245,000
Sound attenuation - duct mounted	700,000	CFM	0.25	175,000
Air distribution, return and exhaust				
Galvanized sheet metal ductwork	959,110	LB	8.00	7,672,880
Flexible ductwork	36,000	LF	6.00	216,000
Dampers, volume	750	EA	40.00	30,000
Dampers, smoke/fire	80	EA	1,200.00	96,000
Insulation/duct liner	400,000	SF	2.50	1,000,000
Diffusers, registers and grilles				
Ceiling				
Core/Shell	1,470	EA	200.00	294,000
Tenant areas, 1 per 150 USF	4,109	EA	150.00	616,350
Parking area				
Terminal & Package Units				
Exhaust fans to toilet rooms etc.	1	LS	300,000.00	300,000
Controls and instrumentation				
DDC Control system	959,110	SF	5.00	4,795,550
Test and balance				
Test and balance	959,110	SF	1.25	1,198,888
				28,033,268

<i>Item Description</i>	<i>Quantity</i>	<i>Unit</i>	<i>Rate</i>	<i>Total</i>
12. Electrical Lighting, Power & Communication				
Primary Service, Medium voltage				
Switchgear 13.8KV including (2) tie breakers, (2) feeder breakers, and customer Transformer substation 13.8KV/480V, double-ended including secondary	12,000	KVA	60.00	720,000
Distribution switchboards - 480V	12,000	KVA	150.00	1,800,000
Distribution panelboards - 480V	12,500	AMP	40.00	500,000
Transformers 480/120V	4,000	AMP	25.00	100,000
Distribution panelboards - 208V	3,000	KVA	75.00	225,000
Feeder conduit and wire - 600V	8,000	AMP	25.00	200,000
	2,000	LF	120.00	240,000
Emergency and Uninterrupted Power				
Emergency Generator	1,500	KVA	350.00	525,000
Automatic transfer switch	1,500	AMP	45.00	67,500
Distribution panelboards	1,500	AMP	25.00	37,500
General Purpose Lighting				
Panelboards	44	EA	2,500.00	110,000
Lighting				
Core Area	147,000	SF	12.00	1,764,000
Tenant Area	616,350	SF	6.00	3,698,100
Parking area	195,760	SF	4.00	783,040
Machine and Equipment Power				
Connections and switches including conduit and wire				
Elevators	16	EA	1,000.00	16,000
Cooling towers	2	EA	5,000.00	10,000
Chillers	2	EA	12,000.00	24,000
Pumps	6	EA	2,000.00	12,000
Miscellaneous connections	959,110	SF	0.75	719,333
User Convenience Power				
Panelboards	88	EA	2,500.00	220,000
Receptacles				
Core/Shell	147,000	SF	3.00	441,000
Tenant Area	616,350	SF	5.00	3,081,750
Parking area	195,760	SF	2.00	391,520
Communications				
Telephone and communications				
Core Area, panels and backbone only	1	LS	75,000.00	75,000
Tenant Area	616,350	SF	3.00	1,849,050

<i>Item Description</i>	<i>Quantity</i>	<i>Unit</i>	<i>Rate</i>	<i>Total</i>
Security Systems				
Security System	959,110	SF	2.00	1,918,220
Fire Alarm Systems				
Fire Alarm Systems	959,110	SF	3.00	2,877,330
Other Electrical Systems				
Grounding Systems	959,110	SF	0.25	239,778
Lightning protection	1	LS	25,000.00	25,000
				22,670,120

13. Fire Protection Systems

Sprinkler and Standpipe Systems				
Fire Protection Sprinkler Systems	959,110	SF	4.00	3,836,440
Standpipe and Hose Systems	959,110	SF	1.00	959,110
Specialties and Other Systems				
Smoke Evacuation	1	LS	250,000.00	250,000
				5,045,550

14. Site Preparation & Building Demolition

Site Preparation	100,000	SF	15.00	1,500,000
				1,500,000

15. Site Paving, Structures & Landscaping

Site Development	50,060	SF	25.00	1,251,500
				1,251,500

16. Utilities on Site

Site Utilities	1	LS	500,000.00	500,000
				500,000

PERFORMANCE BASED COMPONENT SUMMARY

		Gross Area: 959,110 SF	
		\$/SF	\$x1,000
1.	Foundations	17.93	17,193
2.	Vertical Structure	48.39	46,414
3.	Floor & Roof Structures	25.49	24,449
4.	Exterior Cladding	42.43	40,697
5.	Roofing, Waterproofing & Skylights	2.63	2,526
<i>Shell (1-5)</i>		136.88	131,279
6.	Interior Partitions, Doors & Glazing	10.18	9,760
7.	Floor, Wall & Ceiling Finishes	14.34	13,751
<i>Interiors (6-7)</i>		24.51	23,512
8.	Function Equipment & Specialties	9.48	9,090
9.	Stairs & Vertical Transportation	9.99	9,584
<i>Equipment & Vertical Transportation (8-9)</i>		19.47	18,674
10.	Plumbing Systems	6.12	5,872
11.	Heating, Ventilating & Air Conditioning	29.23	28,033
12.	Electric Lighting, Power & Communications	23.64	22,670
13.	Fire Protection Systems	5.26	5,046
<i>Mechanical & Electrical (10-13)</i>		64.25	61,621
Total Building Construction (1-13)		245.11	235,086
14.	Site Preparation & Demolition	1.56	1,500
15.	Site Paving, Structures & Landscaping	1.30	1,252
16.	Utilities on Site	0.52	500
Total Site Construction (14-16)		3.39	3,252
TOTAL BUILDING & SITE (1-16)		248.50	238,338
General Conditions		12.00%	29.82 28,601
Contractor's Overhead & Profit or Fee		6.00%	16.70 16,016
PLANNED CONSTRUCTION COST		March 2010	295.02 282,955
Design, Management and Inspection		20.00%	59.00 56,591
Escalation is excluded		0.00%	0.00 0
RECOMMENDED BUDGET		March 2010	354.02 339,546

<i>Item Description</i>	<i>Quantity</i>	<i>Unit</i>	<i>Rate</i>	<i>Total</i>
1. Foundations				
Mass excavation				
Excavate for basement and Mat foundation	136,085	CY	15.00	2,041,275
Shoring at perimeter	51,852	SF	50.00	2,592,600
Backfill with imported material	28,807	CY	35.00	1,008,233
Dispose off site	136,085	CY	20.00	2,721,700
Hazardous material remediation				Excluded
Foundations				
Reinforced concrete Mat foundation, 10'-0"	49,940	SF	175.00	8,739,500
Elevator pits	6	EA	15,000.00	90,000
				17,193,308
2. Vertical Structure				
Columns and pilasters				
Wide flange	989	TN	4,000.00	3,956,000
Box columns				
Metal plate frame	4,533	TN	6,000.00	27,198,000
Studs- 3/4" diameter, 6" long	85,200	EA	60.00	5,112,000
Concrete fill	2,465	CY	450.00	1,109,250
Sprayed fireproofing	989	TN	350.00	346,150
Diagonal reinforcing				
Buckling restraint braces				
703 k	850	LF	180.00	153,000
589 k	288	LF	150.00	43,200
532 k	912	LF	150.00	136,800
513 k	926	LF	150.00	138,900
418 k	3,402	LF	120.00	408,240
342 k	11,236	LF	120.00	1,348,320
304 k	720	LF	120.00	86,400
266 k	872	LF	100.00	87,200
228 k	988	LF	100.00	98,800
Brace connections				
Gusset plates				
3/4" thick plate steel welded connection	192	EA	1,500.00	288,000
1" thick plate steel welded connection	1,880	EA	2,000.00	3,760,000

<i>Item Description</i>	<i>Quantity</i>	<i>Unit</i>	<i>Rate</i>	<i>Total</i>
Concrete retaining walls				
18" Concrete retaining wall				
Formwork to one side	21,456	SF	15.00	321,840
Reinforcing steel	283,824	LBS	1.15	326,398
Concrete	1,311	CY	225.00	294,975
24" Concrete retaining wall				
Formwork to one side	21,456	SF	15.00	321,840
Reinforcing steel	422,059	LBS	1.15	485,368
Concrete	1,748	CY	225.00	393,300
				46,413,980

3. Floor and Roof Structure

Floor at lowest level				
Slab on grade - See foundations (mat slab)				
Suspended floors				
Wide flange framing	3,144	TN	4,000.00	12,576,000
Channel and angle ledger	101,965	LBS	2.50	254,913
3" formlock deck, 18 ga.	859,230	SF	4.50	3,866,535
3 1/4" lightweight concrete	859,230	SF	5.00	4,296,150
Sprayed fireproofing	3,144	TN	350.00	1,100,400
Plaza level slab/roof				
Wide flange framing	311	TN	4,000.00	1,244,000
Channel and angle ledger	33,988	LBS	2.50	84,970
3" formlock deck, 16 ga.	49,940	SF	4.50	224,730
9" normal weight concrete	49,940	SF	5.00	249,700
Sprayed fireproofing	311	TN	350.00	108,850
High roof				
Wide flange framing	62	TN	4,000.00	248,000
3" formlock deck, 18 ga.	18,190	SF	4.50	81,855
3 1/4" lightweight concrete	18,190	SF	5.00	90,950
Sprayed fireproofing	62	TN	350.00	21,700
				24,448,753

<i>Item Description</i>	<i>Quantity</i>	<i>Unit</i>	<i>Rate</i>	<i>Total</i>
4. Exterior Cladding				
Wall framing, furring and insulation				
Exterior wall framing	301,653	SF	8.00	2,413,224
Furring to interior face of retaining wall	42,912	SF	4.00	171,648
Insulation and vapor barrier	226,240	SF	1.50	339,360
Applied exterior finishes				
Exterior wall finish - curtain wall with spandrel panels	226,240	SF	120.00	27,148,800
Parapets & edge detailing	554	LF	250.00	138,500
Interior finish to exterior walls				
Gypsum board, taped and sanded	269,152	SF	3.50	942,032
Windows, glazing and louvers				
Exterior wall finish - curtain wall with glazing	75,414	SF	120.00	9,049,680
Exterior doors, frames and hardware				
Glazed Doors & Entrances (allow revolving)	12	EA	35,000.00	420,000
Solid Exterior Doors	8	EA	3,000.00	24,000
Overhead Doors	2	EA	25,000.00	50,000
				40,697,244
5. Roofing, Waterproofing & Skylights				
Waterproofing				
Waterproofing at slab on grade	49,940	SF	10.00	499,400
Waterproofing at retaining wall	42,912	SF	10.00	429,120
Waterproofing membrane under plaza	31,750	SF	15.00	476,250
Insulation				
Rigid insulation at roof	18,190	SF	6.00	109,140
Roofing				
Balconies & accessible roofs	31,750	SF	25.00	793,750
High roof	18,190	SF	12.00	218,280
				2,525,940

<i>Item Description</i>	<i>Quantity</i>	<i>Unit</i>	<i>Rate</i>	<i>Total</i>
6. Interior Partitions, Doors & Glazing				
Partition framing and cores				
CMU partitions at basement levels	400	LF	325.00	130,000
Core partitions	7,276	LF	90.00	654,840
Standard partitions	50,932	LF	72.00	3,667,104
Window walls and borrowed lights	1,020	SF	45.00	45,900
Doors, frames & hardware				
Interior doors	2,392	EA	2,200.00	5,262,400
				9,760,244
7. Floor, Wall & Ceiling Finishes				
Floors including base				
Lobby flooring	5,000	SF	35.00	175,000
Core circulation	88,000	SF	6.00	528,000
Restrooms	44,000	SF	15.00	660,000
Office	584,600	SF	5.00	2,923,000
Special use areas	10,000	SF	10.00	100,000
Concrete sealer at basement	195,760	SF	2.00	391,520
Walls				
Lobby	1	EA	75,000.00	75,000
Core circulation	176,000	SF	3.00	528,000
Restroom walls	79,200	SF	15.00	1,188,000
Office	1,137,200	SF	1.50	1,705,800
Special use areas	33,000	SF	5.00	165,000
Paint to concrete and CMU at basement	52,512	SF	1.00	52,512
Ceilings				
Lobby	5,000	SF	25.00	125,000
Core circulation	88,000	SF	12.00	1,056,000
Restrooms	44,000	SF	15.00	660,000
Office	568,600	SF	5.00	2,843,000
Special use areas	22,000	SF	8.00	176,000
Paint to exposed structure at basement	199,760	SF	2.00	399,520
				13,751,352

<i>Item Description</i>	<i>Quantity</i>	<i>Unit</i>	<i>Rate</i>	<i>Total</i>
8. Function Equipment & Specialties				
Built in Equipment				
Lobby/entry	1	LS	25,000.00	25,000
Core area	40	EA	18,000.00	720,000
Office areas	584,600	SF	12.00	7,015,200
Restroom areas	44,000	SF	20.00	880,000
Window washing equipment	1	LS	450,000.00	450,000
				9,090,200

9. Stairs & Vertical Transportation

Stairs				
Regular stair flights	88	EA	22,000.00	1,936,000
Elevators				
Passenger Elevators, gearless traction	264	STOP	28,000.00	7,392,000
Freight Elevators, geared traction, 4 stop	8	STOP	32,000.00	256,000
				9,584,000

10. Plumbing Systems

Sanitary fixtures and connection piping				
Toilets	440	EA	1,600.00	704,000
Urinals	88	EA	1,800.00	158,400
Lavatories	264	EA	1,200.00	316,800
Drinking Fountains and Coolers	44	EA	2,500.00	110,000
Sinks	44	EA	1,700.00	74,800
Hose bibbs	44	EA	500.00	22,000
Domestic water and distribution				
Cold Water Service				
Copper piping incl. fittings >2"	1,300	LF	50.00	65,000
Copper piping incl. fittings to 2"	13,860	LF	32.00	443,520
Hot Water Service				
Copper piping incl. fittings >2"	2,600	LF	50.00	130,000
Copper piping incl. fittings to 2"	27,720	LF	32.00	887,040
Insulation	30,320	LF	9.00	272,880
Valves				
Isolation valves to 3/4"	1,232	EA	65.00	80,080
Domestic Water Supply Equipment				
Hot water heating and circulation	1	LS	200,000.00	200,000

<i>Item Description</i>	<i>Quantity</i>	<i>Unit</i>	<i>Rate</i>	<i>Total</i>
Sanitary waste				
Waste & vent pipework-above ground				
Cast Iron No Hub, >6"	1,300	LF	75.00	97,500
Cast Iron No Hub, to 3"	13,860	LF	32.00	443,520
Sanitary waste, vent and service piping				
Floor Drains	88	EA	1,000.00	88,000
Rain Water Drainage				
Pipe and Fittings	47,609	LF	35.00	1,666,331
Roof/Overflow Drains	83	EA	750.00	62,425
Gas distribution				
Copper piping incl. fittings to 2"	2,000	LF	25.00	50,000
				5,872,296

11. Heating, Ventilation & Air Conditioning

Heat generating systems				
Heating hot water boilers, high efficiency condensing	43,200	MBTH	25.00	1,080,000
Heating hot water pumps	2	EA	35,000.00	70,000
Cooling Generating Systems				
Cooling towers	3,000	TN	350.00	1,050,000
Chillers, 2 each	3,000	TN	550.00	1,650,000
Chilled water pumps	2	EA	30,000.00	60,000
Condenser water pumps	2	EA	28,000.00	56,000
Variable speed drives, vibration isolation, etc.	6	EA	12,000.00	72,000
Distribution systems				
Piping, fittings, valves and insulation				
Chilled water				
Chilled water pipework, fittings	1,400	LF	95.00	133,000
Valves and specialties	1	LS	75,000.00	75,000
Heating hot water				
Heating hot water pipework, fittings, including insulation				
6" - 4"	1,200	LF	85.00	102,000
< = 3"	36,000	LF	30.00	1,080,000
Valves and specialties	1	LS	150,000.00	150,000
Condenser water				
Condenser water pipework, fittings	1,200	LF	90.00	108,000
Valves and specialties	1	LS	25,000.00	25,000
Connections to VAV boxes	1,517	EA	350.00	531,038

<i>Item Description</i>	<i>Quantity</i>	<i>Unit</i>	<i>Rate</i>	<i>Total</i>
Air handling equipment				
Air handler units	700,000	CFM	5.00	3,500,000
VAV boxes				
Core/Shell	294	EA	1,250.00	367,500
Tenant areas, 1 per 600 USF	1,027	EA	1,250.00	1,284,063
Parking area	196	EA	1,250.00	245,000
Sound attenuation - duct mounted	700,000	CFM	0.25	175,000
Air distribution, return and exhaust				
Galvanized sheet metal ductwork	959,110	LB	8.00	7,672,880
Flexible ductwork	36,000	LF	6.00	216,000
Dampers, volume	750	EA	40.00	30,000
Dampers, smoke/fire	80	EA	1,200.00	96,000
Insulation/duct liner	400,000	SF	2.50	1,000,000
Diffusers, registers and grilles				
Ceiling				
Core/Shell	1,470	EA	200.00	294,000
Tenant areas, 1 per 150 USF	4,109	EA	150.00	616,350
Parking area				
Terminal & Package Units				
Exhaust fans to toilet rooms etc.	1	LS	300,000.00	300,000
Controls and instrumentation				
DDC Control system	959,110	SF	5.00	4,795,550
Test and balance				
Test and balance	959,110	SF	1.25	1,198,888
				28,033,268

12. Electrical Lighting, Power & Communication

Primary Service, Medium voltage				
Switchgear 13.8KV including (2) tie breakers, (2) feeder breakers, and customer Transformer substation 13.8KV/480V, double-ended including secondary	12,000	KVA	60.00	720,000
Distribution switchboards - 480V	12,500	AMP	40.00	500,000
Distribution panelboards - 480V	4,000	AMP	25.00	100,000
Transformers 480/120V	3,000	KVA	75.00	225,000
Distribution panelboards - 208V	8,000	AMP	25.00	200,000
Feeder conduit and wire - 600V	2,000	LF	120.00	240,000

<i>Item Description</i>	<i>Quantity</i>	<i>Unit</i>	<i>Rate</i>	<i>Total</i>
Emergency and Uninterrupted Power				
Emergency Generator	1,500	KVA	350.00	525,000
Automatic transfer switch	1,500	AMP	45.00	67,500
Distribution panelboards	1,500	AMP	25.00	37,500
General Purpose Lighting				
Panelboards	44	EA	2,500.00	110,000
Lighting				
Core Area	147,000	SF	12.00	1,764,000
Tenant Area	616,350	SF	6.00	3,698,100
Parking area	195,760	SF	4.00	783,040
Machine and Equipment Power				
Connections and switches including conduit and wire				
Elevators	16	EA	1,000.00	16,000
Cooling towers	2	EA	5,000.00	10,000
Chillers	2	EA	12,000.00	24,000
Pumps	6	EA	2,000.00	12,000
Miscellaneous connections	959,110	SF	0.75	719,333
User Convenience Power				
Panelboards	88	EA	2,500.00	220,000
Receptacles				
Core/Shell	147,000	SF	3.00	441,000
Tenant Area	616,350	SF	5.00	3,081,750
Parking area	195,760	SF	2.00	391,520
Communications				
Telephone and communications				
Core Area, panels and backbone only	1	LS	75,000.00	75,000
Tenant Area	616,350	SF	3.00	1,849,050
Security Systems				
Security System	959,110	SF	2.00	1,918,220
Fire Alarm Systems				
Fire Alarm Systems	959,110	SF	3.00	2,877,330
Other Electrical Systems				
Grounding Systems	959,110	SF	0.25	239,778
Lightning protection	1	LS	25,000.00	25,000
				22,670,120

<i>Item Description</i>	<i>Quantity</i>	<i>Unit</i>	<i>Rate</i>	<i>Total</i>
13. Fire Protection Systems				
Sprinkler and Standpipe Systems				
Fire Protection Sprinkler Systems	959,110	SF	4.00	3,836,440
Standpipe and Hose Systems	959,110	SF	1.00	959,110
Specialties and Other Systems				
Smoke Evacuation	1	LS	250,000.00	250,000
				5,045,550
14. Site Preparation & Building Demolition				
Site Preparation	100,000	SF	15.00	1,500,000
				1,500,000
15. Site Paving, Structures & Landscaping				
Site Development	50,060	SF	25.00	1,251,500
				1,251,500
16. Utilities on Site				
Site Utilities	1	LS	500,000.00	500,000
				500,000

PERFORMANCE BASED PLUS COMPONENT SUMMARY

Gross Area: 959,110 SF			
		\$/SF	\$x1,000
1. Foundations		17.93	17,193
2. Vertical Structure		52.90	50,733
3. Floor & Roof Structures		25.87	24,814
4. Exterior Cladding		42.43	40,697
5. Roofing, Waterproofing & Skylights		2.63	2,526
Shell (1-5)		141.76	135,964
6. Interior Partitions, Doors & Glazing		10.18	9,760
7. Floor, Wall & Ceiling Finishes		14.34	13,751
Interiors (6-7)		24.51	23,512
8. Function Equipment & Specialties		8.77	8,410
9. Stairs & Vertical Transportation		9.99	9,584
Equipment & Vertical Transportation (8-9)		18.76	17,994
10. Plumbing Systems		6.12	5,872
11. Heating, Ventilating & Air Conditioning		29.23	28,033
12. Electric Lighting, Power & Communications		23.64	22,670
13. Fire Protection Systems		5.26	5,046
Mechanical & Electrical (10-13)		64.25	61,621
Total Building Construction (1-13)		249.28	239,091
14. Site Preparation & Demolition		1.56	1,500
15. Site Paving, Structures & Landscaping		1.30	1,252
16. Utilities on Site		0.52	500
Total Site Construction (14-16)		3.39	3,252
TOTAL BUILDING & SITE (1-16)		252.67	242,343
General Conditions	12.00%	30.32	29,081
Contractor's Overhead & Profit or Fee	6.00%	16.98	16,285
PLANNED CONSTRUCTION COST		March 2010	299.97
Design, Management and Inspection	20.00%	60.00	57,542
Escalation is excluded	0.00%	0.00	0
RECOMMENDED BUDGET		March 2010	359.97
			345,251

<i>Item Description</i>	<i>Quantity</i>	<i>Unit</i>	<i>Rate</i>	<i>Total</i>
1. Foundations				
Mass excavation				
Excavate for basement and Mat foundation	136,085	CY	15.00	2,041,275
Shoring at perimeter	51,852	SF	50.00	2,592,600
Backfill with imported material	28,807	CY	35.00	1,008,233
Dispose off site	136,085	CY	20.00	2,721,700
Hazardous material remediation				
Foundations				
Reinforced concrete Mat foundation, 10'-0"	49,940	SF	175.00	8,739,500
Elevator pits	6	EA	15,000.00	90,000
				17,193,308
2. Vertical Structure				
Columns and pilasters				
Wide flange	1,117	TN	4,000.00	4,468,000
Box columns				
Metal plate frame	4,980	TN	6,000.00	29,880,000
Studs- 3/4" diameter, 6" long	90,144	EA	60.00	5,408,640
Concrete fill	2,687	CY	450.00	1,209,150
Sprayed fireproofing	1,117	TN	350.00	390,950
Diagonal reinforcing				
Buckling restraint braces				
950 k	192	LF	225.00	43,200
703 k	1,458	LF	180.00	262,440
665 k	192	LF	180.00	34,560
589 k	592	LF	150.00	88,800
513 k	926	LF	150.00	138,900
456 k	6,292	LF	150.00	943,800
418 k	8,912	LF	120.00	1,069,440
380 k	880	LF	120.00	105,600
342 k	228	LF	120.00	27,360
304 k	480	LF	120.00	57,600
266 k	1,252	LF	100.00	125,200
Brace connections				
Gusset plates				
3/4" thick plate steel welded connection	128	EA	1,500.00	192,000
1" thick plate steel welded connection	2,040	EA	2,000.00	4,080,000
2" thick plate steel welded connection	16	EA	4,000.00	64,000

<i>Item Description</i>	<i>Quantity</i>	<i>Unit</i>	<i>Rate</i>	<i>Total</i>
Concrete retaining walls				
18" Concrete retaining wall				
Formwork to one side	21,456	SF	15.00	321,840
Reinforcing steel	283,824	LBS	1.15	326,398
Concrete	1,311	CY	225.00	294,975
24" Concrete retaining wall				
Formwork to one side	21,456	SF	15.00	321,840
Reinforcing steel	422,059	LBS	1.15	485,368
Concrete	1,748	CY	225.00	393,300
				50,733,360

3. Floor and Roof Structure

Floor at lowest level				
Slab on grade - See foundations (mat slab)				
Suspended floors				
Wide flange framing	3,218	TN	4,000.00	12,872,000
Channel and angle ledger	101,965	LBS	2.50	254,913
3" formlock deck, 18 ga.	859,230	SF	4.50	3,866,535
3 1/4" lightweight concrete	859,230	SF	5.00	4,296,150
Sprayed fireproofing	3,218	TN	350.00	1,126,300
Plaza level slab/roof				
Wide flange framing	311	TN	4,000.00	1,244,000
Channel and angle ledger	33,988	LBS	2.50	84,970
3" formlock deck, 16 ga.	49,940	SF	4.50	224,730
9" normal weight concrete	49,940	SF	5.00	249,700
Sprayed fireproofing	311	TN	350.00	108,850
High roof				
Wide flange framing	72	TN	4,000.00	288,000
3" formlock deck, 18 ga.	18,190	SF	4.50	81,855
3 1/4" lightweight concrete	18,190	SF	5.00	90,950
Sprayed fireproofing	72	TN	350.00	25,200
				24,814,153

<i>Item Description</i>	<i>Quantity</i>	<i>Unit</i>	<i>Rate</i>	<i>Total</i>
4. Exterior Cladding				
Wall framing, furring and insulation				
Exterior wall framing	301,653	SF	8.00	2,413,224
Furring to interior face of retaining wall	42,912	SF	4.00	171,648
Insulation and vapor barrier	226,240	SF	1.50	339,360
Applied exterior finishes				
Exterior wall finish - curtain wall with spandrel panels	226,240	SF	120.00	27,148,800
Parapets & edge detailing	554	LF	250.00	138,500
Interior finish to exterior walls				
Gypsum board, taped and sanded	269,152	SF	3.50	942,032
Windows, glazing and louvers				
Exterior wall finish - curtain wall with glazing	75,414	SF	120.00	9,049,680
Exterior doors, frames and hardware				
Glazed Doors & Entrances (allow revolving)	12	EA	35,000.00	420,000
Solid Exterior Doors	8	EA	3,000.00	24,000
Overhead Doors	2	EA	25,000.00	50,000
				40,697,244
5. Roofing, Waterproofing & Skylights				
Waterproofing				
Waterproofing at slab on grade	49,940	SF	10.00	499,400
Waterproofing at retaining wall	42,912	SF	10.00	429,120
Waterproofing membrane under plaza	31,750	SF	15.00	476,250
Insulation				
Rigid insulation at roof	18,190	SF	6.00	109,140
Roofing				
Balconies & accessible roofs	31,750	SF	25.00	793,750
High roof	18,190	SF	12.00	218,280
				2,525,940

<i>Item Description</i>	<i>Quantity</i>	<i>Unit</i>	<i>Rate</i>	<i>Total</i>
6. Interior Partitions, Doors & Glazing				
Partition framing and cores				
CMU partitions at basement levels	400	LF	325.00	130,000
Core partitions	7,276	LF	90.00	654,840
Standard partitions	50,932	LF	72.00	3,667,104
Window walls and borrowed lights	1,020	SF	45.00	45,900
Doors, frames & hardware				
Interior doors	2,392	EA	2,200.00	5,262,400
				9,760,244
7. Floor, Wall & Ceiling Finishes				
Floors including base				
Lobby flooring	5,000	SF	35.00	175,000
Core circulation	88,000	SF	6.00	528,000
Restrooms	44,000	SF	15.00	660,000
Office	584,600	SF	5.00	2,923,000
Special use areas	10,000	SF	10.00	100,000
Concrete sealer at basement	195,760	SF	2.00	391,520
Walls				
Lobby	1	EA	75,000.00	75,000
Core circulation	176,000	SF	3.00	528,000
Restroom walls	79,200	SF	15.00	1,188,000
Office	1,137,200	SF	1.50	1,705,800
Special use areas	33,000	SF	5.00	165,000
Paint to concrete and CMU at basement	52,512	SF	1.00	52,512
Ceilings				
Lobby	5,000	SF	25.00	125,000
Core circulation	88,000	SF	12.00	1,056,000
Restrooms	44,000	SF	15.00	660,000
Office	568,600	SF	5.00	2,843,000
Special use areas	22,000	SF	8.00	176,000
Paint to exposed structure at basement	199,760	SF	2.00	399,520
				13,751,352

<i>Item Description</i>	<i>Quantity</i>	<i>Unit</i>	<i>Rate</i>	<i>Total</i>
8. Function Equipment & Specialties				
Built in Equipment				
Lobby/entry	1	LS	25,000.00	25,000
Core area	40	EA	18,000.00	720,000
Office areas	584,600	SF	12.00	7,015,200
Restroom areas	10,000	SF	20.00	200,000
Window washing equipment	1	LS	450,000.00	450,000
				8,410,200

9. Stairs & Vertical Transportation

Stairs				
Regular stair flights	88	EA	22,000.00	1,936,000
Elevators				
Passenger Elevators, gearless traction	264	STOP	28,000.00	7,392,000
Freight Elevators, geared traction, 4 stop	8	STOP	32,000.00	256,000
				9,584,000

10. Plumbing Systems

Sanitary fixtures and connection piping				
Toilets	440	EA	1,600.00	704,000
Urinals	88	EA	1,800.00	158,400
Lavatories	264	EA	1,200.00	316,800
Drinking Fountains and Coolers	44	EA	2,500.00	110,000
Sinks	44	EA	1,700.00	74,800
Hose bibbs	44	EA	500.00	22,000
Domestic water and distribution				
Cold Water Service				
Copper piping incl. fittings >2"	1,300	LF	50.00	65,000
Copper piping incl. fittings to 2"	13,860	LF	32.00	443,520
Hot Water Service				
Copper piping incl. fittings >2"	2,600	LF	50.00	130,000
Copper piping incl. fittings to 2"	27,720	LF	32.00	887,040
Insulation	30,320	LF	9.00	272,880
Valves				
Isolation valves to 3/4"	1,232	EA	65.00	80,080
Domestic Water Supply Equipment				
Hot water heating and circulation	1	LS	200,000.00	200,000

<i>Item Description</i>	<i>Quantity</i>	<i>Unit</i>	<i>Rate</i>	<i>Total</i>
Sanitary waste				
Waste & vent pipework-above ground				
Cast Iron No Hub, >6"	1,300	LF	75.00	97,500
Cast Iron No Hub, to 3"	13,860	LF	32.00	443,520
Sanitary waste, vent and service piping				
Floor Drains	88	EA	1,000.00	88,000
Rain Water Drainage				
Pipe and Fittings	47,609	LF	35.00	1,666,331
Roof/Overflow Drains	83	EA	750.00	62,425
Gas distribution				
Copper piping incl. fittings to 2"	2,000	LF	25.00	50,000
				5,872,296

11. Heating, Ventilation & Air Conditioning

Heat generating systems				
Heating hot water boilers, high efficiency condensing	43,200	MBTH	25.00	1,080,000
Heating hot water pumps	2	EA	35,000.00	70,000
Cooling Generating Systems				
Cooling towers	3,000	TN	350.00	1,050,000
Chillers, 2 each	3,000	TN	550.00	1,650,000
Chilled water pumps	2	EA	30,000.00	60,000
Condenser water pumps	2	EA	28,000.00	56,000
Variable speed drives, vibration isolation, etc.	6	EA	12,000.00	72,000
Distribution systems				
Piping, fittings, valves and insulation				
Chilled water				
Chilled water pipework, fittings	1,400	LF	95.00	133,000
Valves and specialties	1	LS	75,000.00	75,000
Heating hot water				
Heating hot water pipework, fittings, including insulation				
6" - 4"	1,200	LF	85.00	102,000
< = 3"	36,000	LF	30.00	1,080,000
Valves and specialties	1	LS	150,000.00	150,000
Condenser water				
Condenser water pipework, fittings	1,200	LF	90.00	108,000
Valves and specialties	1	LS	25,000.00	25,000
Connections to VAV boxes	1,517	EA	350.00	531,038

<i>Item Description</i>	<i>Quantity</i>	<i>Unit</i>	<i>Rate</i>	<i>Total</i>
Air handling equipment				
Air handler units	700,000	CFM	5.00	3,500,000
VAV boxes				
Core/Shell	294	EA	1,250.00	367,500
Tenant areas, 1 per 600 USF	1,027	EA	1,250.00	1,284,063
Parking area	196	EA	1,250.00	245,000
Sound attenuation - duct mounted	700,000	CFM	0.25	175,000
Air distribution, return and exhaust				
Galvanized sheet metal ductwork	959,110	LB	8.00	7,672,880
Flexible ductwork	36,000	LF	6.00	216,000
Dampers, volume	750	EA	40.00	30,000
Dampers, smoke/fire	80	EA	1,200.00	96,000
Insulation/duct liner	400,000	SF	2.50	1,000,000
Diffusers, registers and grilles				
Ceiling				
Core/Shell	1,470	EA	200.00	294,000
Tenant areas, 1 per 150 USF	4,109	EA	150.00	616,350
Parking area				
Terminal & Package Units				
Exhaust fans to toilet rooms etc.	1	LS	300,000.00	300,000
Controls and instrumentation				
DDC Control system	959,110	SF	5.00	4,795,550
Test and balance				
Test and balance	959,110	SF	1.25	1,198,888
				28,033,268

12. Electrical Lighting, Power & Communication

Primary Service, Medium voltage				
Switchgear 13.8KV including (2) tie breakers, (2) feeder breakers, and customer Transformer substation 13.8KV/480V,	12,000	KVA	60.00	720,000
double-ended including secondary	12,000	KVA	150.00	1,800,000
Distribution switchboards - 480V	12,500	AMP	40.00	500,000
Distribution panelboards - 480V	4,000	AMP	25.00	100,000
Transformers 480/120V	3,000	KVA	75.00	225,000
Distribution panelboards - 208V	8,000	AMP	25.00	200,000
Feeder conduit and wire - 600V	2,000	LF	120.00	240,000

<i>Item Description</i>	<i>Quantity</i>	<i>Unit</i>	<i>Rate</i>	<i>Total</i>
Emergency and Uninterrupted Power				
Emergency Generator	1,500	KVA	350.00	525,000
Automatic transfer switch	1,500	AMP	45.00	67,500
Distribution panelboards	1,500	AMP	25.00	37,500
General Purpose Lighting				
Panelboards	44	EA	2,500.00	110,000
Lighting				
Core Area	147,000	SF	12.00	1,764,000
Tenant Area	616,350	SF	6.00	3,698,100
Parking area	195,760	SF	4.00	783,040
Machine and Equipment Power				
Connections and switches including conduit and wire				
Elevators	16	EA	1,000.00	16,000
Cooling towers	2	EA	5,000.00	10,000
Chillers	2	EA	12,000.00	24,000
Pumps	6	EA	2,000.00	12,000
Miscellaneous connections	959,110	SF	0.75	719,333
User Convenience Power				
Panelboards	88	EA	2,500.00	220,000
Receptacles				
Core/Shell	147,000	SF	3.00	441,000
Tenant Area	616,350	SF	5.00	3,081,750
Parking area	195,760	SF	2.00	391,520
Communications				
Telephone and communications				
Core Area, panels and backbone only	1	LS	75,000.00	75,000
Tenant Area	616,350	SF	3.00	1,849,050
Security Systems				
Security System	959,110	SF	2.00	1,918,220
Fire Alarm Systems				
Fire Alarm Systems	959,110	SF	3.00	2,877,330
Other Electrical Systems				
Grounding Systems	959,110	SF	0.25	239,778
Lightning protection	1	LS	25,000.00	25,000
				22,670,120

<i>Item Description</i>	<i>Quantity</i>	<i>Unit</i>	<i>Rate</i>	<i>Total</i>
13. Fire Protection Systems				
Sprinkler and Standpipe Systems				
Fire Protection Sprinkler Systems	959,110	SF	4.00	3,836,440
Standpipe and Hose Systems	959,110	SF	1.00	959,110
Specialties and Other Systems				
Smoke Evacuation	1	LS	250,000.00	250,000
				5,045,550
14. Site Preparation & Building Demolition				
Site Preparation	100,000	SF	15.00	1,500,000
				1,500,000
15. Site Paving, Structures & Landscaping				
Site Development	50,060	SF	25.00	1,251,500
				1,251,500
16. Utilities on Site				
Site Utilities	1	LS	500,000.00	500,000
				500,000

PEER REPORTS

PEER reports are available individually or by yearly subscription. PEER reports can be ordered at http://peer.berkeley.edu/publications/peer_reports.html or by contacting the Pacific Earthquake Engineering Research Center, 325 Davis Hall mail code 1792, Berkeley, CA 94720. Tel.: (510) 642-3437; Fax: (510) 665-1655; Email: peer_editor@berkeley.edu

- PEER 2011/05** *Case Studies of the Seismic Performance of Tall Buildings Designed by Alternative Means.* Task 12 Report for the Tall Buildings Initiative. Jack Moehle, Yousef Bozorgnia, Nirmal Jayaram, Pierson Jones, Mohsen Rahnama, Nilesh Shome, Zeynep Tuna, John Wallace, Tony Yang, and Farzin Zareian. July 2011.
- PEER 2011/04** *Recommended Design Practice for Pile Foundations in Laterally Spreading Ground.* Scott A. Ashford, Ross W. Boulanger, and Scott J. Brandenburg. June 2011.
- PEER 2011/03** *New Ground Motion Selection Procedures and Selected Motions for the PEER Transportation Research Program.* Jack W. Baker, Ting Lin, Shrey K. Shahi, and Nirmal Jayaram. March 2011.
- PEER 2011/02** *A Bayesian Network Methodology for Infrastructure Seismic Risk Assessment and Decision Support.* Michelle T. Bensi, Armen Der Kiureghian, and Daniel Straub. March 2011.
- PEER 2011/01** *Demand Fragility Surfaces for Bridges in Liquefied and Laterally Spreading Ground.* Scott J. Brandenburg, Jian Zhang, Pirooz Kashighandi, Yili Huo, and Minxing Zhao. March 2011.
- PEER 2010/05** *Guidelines for Performance-Based Seismic Design of Tall Buildings.* Developed by the Tall Buildings Initiative. November 2010.
- PEER 2010/04** *Application Guide for the Design of Flexible and Rigid Bus Connections between Substation Equipment Subjected to Earthquakes.* Jean-Bernard Dastous and Armen Der Kiureghian. September 2010.
- PEER 2010/03** *Shear Wave Velocity as a Statistical Function of Standard Penetration Test Resistance and Vertical Effective Stress at Caltrans Bridge Sites.* Scott J. Brandenburg, Naresh Bellana, and Thomas Shantz. June 2010.
- PEER 2010/02** *Stochastic Modeling and Simulation of Ground Motions for Performance-Based Earthquake Engineering.* Sanaz Rezaeian and Armen Der Kiureghian. June 2010.
- PEER 2010/01** *Structural Response and Cost Characterization of Bridge Construction Using Seismic Performance Enhancement Strategies.* Ady Aviram, Božidar Stojadinović, Gustavo J. Parra-Montesinos, and Kevin R. Mackie. March 2010.
- PEER 2009/03** *The Integration of Experimental and Simulation Data in the Study of Reinforced Concrete Bridge Systems Including Soil-Foundation-Structure Interaction.* Matthew Dryden and Gregory L. Fenves. November 2009.
- PEER 2009/02** *Improving Earthquake Mitigation through Innovations and Applications in Seismic Science, Engineering, Communication, and Response. Proceedings of a U.S.-Iran Seismic Workshop.* October 2009.
- PEER 2009/01** *Evaluation of Ground Motion Selection and Modification Methods: Predicting Median Interstory Drift Response of Buildings.* Curt B. Haselton, Ed. June 2009.
- PEER 2008/10** *Technical Manual for Strata.* Albert R. Kottke and Ellen M. Rathje. February 2009.
- PEER 2008/09** *NGA Model for Average Horizontal Component of Peak Ground Motion and Response Spectra.* Brian S.-J. Chiou and Robert R. Youngs. November 2008.
- PEER 2008/08** *Toward Earthquake-Resistant Design of Concentrically Braced Steel Structures.* Patxi Uriz and Stephen A. Mahin. November 2008.
- PEER 2008/07** *Using OpenSees for Performance-Based Evaluation of Bridges on Liquefiable Soils.* Stephen L. Kramer, Pedro Arduino, and HyungSuk Shin. November 2008.
- PEER 2008/06** *Shaking Table Tests and Numerical Investigation of Self-Centering Reinforced Concrete Bridge Columns.* Hyung IL Jeong, Junichi Sakai, and Stephen A. Mahin. September 2008.
- PEER 2008/05** *Performance-Based Earthquake Engineering Design Evaluation Procedure for Bridge Foundations Undergoing Liquefaction-Induced Lateral Ground Displacement.* Christian A. Ledezma and Jonathan D. Bray. August 2008.
- PEER 2008/04** *Benchmarking of Nonlinear Geotechnical Ground Response Analysis Procedures.* Jonathan P. Stewart, Annie On-Lei Kwok, Youssef M. A. Hashash, Neven Matasovic, Robert Pyke, Zhiliang Wang, and Zhaohui Yang. August 2008.
- PEER 2008/03** *Guidelines for Nonlinear Analysis of Bridge Structures in California.* Ady Aviram, Kevin R. Mackie, and Božidar Stojadinović. August 2008.
- PEER 2008/02** *Treatment of Uncertainties in Seismic-Risk Analysis of Transportation Systems.* Evangelos Stergiou and Anne S. Kiremidjian. July 2008.

- PEER 2008/01** *Seismic Performance Objectives for Tall Buildings.* William T. Holmes, Charles Kircher, William Petak, and Nabih Youssef. August 2008.
- PEER 2007/12** *An Assessment to Benchmark the Seismic Performance of a Code-Conforming Reinforced Concrete Moment-Frame Building.* Curt Haselton, Christine A. Goulet, Judith Mitrani-Reiser, James L. Beck, Gregory G. Deierlein, Keith A. Porter, Jonathan P. Stewart, and Ertugrul Taciroglu. August 2008.
- PEER 2007/11** *Bar Buckling in Reinforced Concrete Bridge Columns.* Wayne A. Brown, Dawn E. Lehman, and John F. Stanton. February 2008.
- PEER 2007/10** *Computational Modeling of Progressive Collapse in Reinforced Concrete Frame Structures.* Mohamed M. Talaat and Khalid M. Mosalam. May 2008.
- PEER 2007/09** *Integrated Probabilistic Performance-Based Evaluation of Benchmark Reinforced Concrete Bridges.* Kevin R. Mackie, John-Michael Wong, and Božidar Stojadinović. January 2008.
- PEER 2007/08** *Assessing Seismic Collapse Safety of Modern Reinforced Concrete Moment-Frame Buildings.* Curt B. Haselton and Gregory G. Deierlein. February 2008.
- PEER 2007/07** *Performance Modeling Strategies for Modern Reinforced Concrete Bridge Columns.* Michael P. Berry and Marc O. Eberhard. April 2008.
- PEER 2007/06** *Development of Improved Procedures for Seismic Design of Buried and Partially Buried Structures.* Linda Al Atik and Nicholas Sitar. June 2007.
- PEER 2007/05** *Uncertainty and Correlation in Seismic Risk Assessment of Transportation Systems.* Renee G. Lee and Anne S. Kiremidjian. July 2007.
- PEER 2007/04** *Numerical Models for Analysis and Performance-Based Design of Shallow Foundations Subjected to Seismic Loading.* Sivapalan Gajan, Tara C. Hutchinson, Bruce L. Kutter, Prishati Raychowdhury, José A. Ugalde, and Jonathan P. Stewart. May 2008.
- PEER 2007/03** *Beam-Column Element Model Calibrated for Predicting Flexural Response Leading to Global Collapse of RC Frame Buildings.* Curt B. Haselton, Abbie B. Liel, Sarah Taylor Lange, and Gregory G. Deierlein. May 2008.
- PEER 2007/02** *Campbell-Bozorgnia NGA Ground Motion Relations for the Geometric Mean Horizontal Component of Peak and Spectral Ground Motion Parameters.* Kenneth W. Campbell and Yousef Bozorgnia. May 2007.
- PEER 2007/01** *Boore-Atkinson NGA Ground Motion Relations for the Geometric Mean Horizontal Component of Peak and Spectral Ground Motion Parameters.* David M. Boore and Gail M. Atkinson. May 2007.
- PEER 2006/12** *Societal Implications of Performance-Based Earthquake Engineering.* Peter J. May. May 2007.
- PEER 2006/11** *Probabilistic Seismic Demand Analysis Using Advanced Ground Motion Intensity Measures, Attenuation Relationships, and Near-Fault Effects.* Polsak Tothong and C. Allin Cornell. March 2007.
- PEER 2006/10** *Application of the PEER PBEE Methodology to the I-880 Viaduct.* Sashi Kunnath. February 2007.
- PEER 2006/09** *Quantifying Economic Losses from Travel Forgone Following a Large Metropolitan Earthquake.* James Moore, Sungbin Cho, Yue Yue Fan, and Stuart Werner. November 2006.
- PEER 2006/08** *Vector-Valued Ground Motion Intensity Measures for Probabilistic Seismic Demand Analysis.* Jack W. Baker and C. Allin Cornell. October 2006.
- PEER 2006/07** *Analytical Modeling of Reinforced Concrete Walls for Predicting Flexural and Coupled-Shear-Flexural Responses.* Kutay Orakcal, Leonardo M. Massone, and John W. Wallace. October 2006.
- PEER 2006/06** *Nonlinear Analysis of a Soil-Drilled Pier System under Static and Dynamic Axial Loading.* Gang Wang and Nicholas Sitar. November 2006.
- PEER 2006/05** *Advanced Seismic Assessment Guidelines.* Paolo Bazzurro, C. Allin Cornell, Charles Menun, Maziar Motahari, and Nicolas Luco. September 2006.
- PEER 2006/04** *Probabilistic Seismic Evaluation of Reinforced Concrete Structural Components and Systems.* Tae Hyung Lee and Khalid M. Mosalam. August 2006.
- PEER 2006/03** *Performance of Lifelines Subjected to Lateral Spreading.* Scott A. Ashford and Teerawut Juirnarongrit. July 2006.
- PEER 2006/02** *Pacific Earthquake Engineering Research Center Highway Demonstration Project.* Anne Kiremidjian, James Moore, Yue Yue Fan, Nesrin Basoz, Ozgur Yazali, and Meredith Williams. April 2006.
- PEER 2006/01** *Bracing Berkeley. A Guide to Seismic Safety on the UC Berkeley Campus.* Mary C. Comerio, Stephen Tobriner, and Ariane Fehrenkamp. January 2006.
- PEER 2005/16** *Seismic Response and Reliability of Electrical Substation Equipment and Systems.* Junho Song, Armen Der Kiureghian, and Jerome L. Sackman. April 2006.

- PEER 2005/15** *CPT-Based Probabilistic Assessment of Seismic Soil Liquefaction Initiation.* R. E. S. Moss, R. B. Seed, R. E. Kayen, J. P. Stewart, and A. Der Kiureghian. April 2006.
- PEER 2005/14** *Workshop on Modeling of Nonlinear Cyclic Load-Deformation Behavior of Shallow Foundations.* Bruce L. Kutter, Geoffrey Martin, Tara Hutchinson, Chad Harden, Sivapalan Gajan, and Justin Phalen. March 2006.
- PEER 2005/13** *Stochastic Characterization and Decision Bases under Time-Dependent Aftershock Risk in Performance-Based Earthquake Engineering.* Gee Liek Yeo and C. Allin Cornell. July 2005.
- PEER 2005/12** *PEER Testbed Study on a Laboratory Building: Exercising Seismic Performance Assessment.* Mary C. Comerio, editor. November 2005.
- PEER 2005/11** *Van Nuys Hotel Building Testbed Report: Exercising Seismic Performance Assessment.* Helmut Krawinkler, editor. October 2005.
- PEER 2005/10** *First NEES/E-Defense Workshop on Collapse Simulation of Reinforced Concrete Building Structures.* September 2005.
- PEER 2005/09** *Test Applications of Advanced Seismic Assessment Guidelines.* Joe Maffei, Karl Telleen, Danya Mohr, William Holmes, and Yuki Nakayama. August 2006.
- PEER 2005/08** *Damage Accumulation in Lightly Confined Reinforced Concrete Bridge Columns.* R. Tyler Ranf, Jared M. Nelson, Zach Price, Marc O. Eberhard, and John F. Stanton. April 2006.
- PEER 2005/07** *Experimental and Analytical Studies on the Seismic Response of Freestanding and Anchored Laboratory Equipment.* Dimitrios Konstantinidis and Nicos Makris. January 2005.
- PEER 2005/06** *Global Collapse of Frame Structures under Seismic Excitations.* Luis F. Ibarra and Helmut Krawinkler. September 2005.
- PEER 2005/05** *Performance Characterization of Bench- and Shelf-Mounted Equipment.* Samit Ray Chaudhuri and Tara C. Hutchinson. May 2006.
- PEER 2005/04** *Numerical Modeling of the Nonlinear Cyclic Response of Shallow Foundations.* Chad Harden, Tara Hutchinson, Geoffrey R. Martin, and Bruce L. Kutter. August 2005.
- PEER 2005/03** *A Taxonomy of Building Components for Performance-Based Earthquake Engineering.* Keith A. Porter. September 2005.
- PEER 2005/02** *Fragility Basis for California Highway Overpass Bridge Seismic Decision Making.* Kevin R. Mackie and Božidar Stojadinović. June 2005.
- PEER 2005/01** *Empirical Characterization of Site Conditions on Strong Ground Motion.* Jonathan P. Stewart, Yoojoong Choi, and Robert W. Graves. June 2005.
- PEER 2004/09** *Electrical Substation Equipment Interaction: Experimental Rigid Conductor Studies.* Christopher Stearns and André Filiatrault. February 2005.
- PEER 2004/08** *Seismic Qualification and Fragility Testing of Line Break 550-kV Disconnect Switches.* Shakhzod M. Takhirov, Gregory L. Fenves, and Eric Fujisaki. January 2005.
- PEER 2004/07** *Ground Motions for Earthquake Simulator Qualification of Electrical Substation Equipment.* Shakhzod M. Takhirov, Gregory L. Fenves, Eric Fujisaki, and Don Clyde. January 2005.
- PEER 2004/06** *Performance-Based Regulation and Regulatory Regimes.* Peter J. May and Chris Koski. September 2004.
- PEER 2004/05** *Performance-Based Seismic Design Concepts and Implementation: Proceedings of an International Workshop.* Peter Fajfar and Helmut Krawinkler, editors. September 2004.
- PEER 2004/04** *Seismic Performance of an Instrumented Tilt-up Wall Building.* James C. Anderson and Vitelmo V. Bertero. July 2004.
- PEER 2004/03** *Evaluation and Application of Concrete Tilt-up Assessment Methodologies.* Timothy Graf and James O. Malley. October 2004.
- PEER 2004/02** *Analytical Investigations of New Methods for Reducing Residual Displacements of Reinforced Concrete Bridge Columns.* Junichi Sakai and Stephen A. Mahin. August 2004.
- PEER 2004/01** *Seismic Performance of Masonry Buildings and Design Implications.* Kerri Anne Taeko Tokoro, James C. Anderson, and Vitelmo V. Bertero. February 2004.
- PEER 2003/18** *Performance Models for Flexural Damage in Reinforced Concrete Columns.* Michael Berry and Marc Eberhard. August 2003.
- PEER 2003/17** *Predicting Earthquake Damage in Older Reinforced Concrete Beam-Column Joints.* Catherine Pagni and Laura Lowes. October 2004.

- PEER 2003/16** *Seismic Demands for Performance-Based Design of Bridges.* Kevin Mackie and Božidar Stojadinović. August 2003.
- PEER 2003/15** *Seismic Demands for Nondeteriorating Frame Structures and Their Dependence on Ground Motions.* Ricardo Antonio Medina and Helmut Krawinkler. May 2004.
- PEER 2003/14** *Finite Element Reliability and Sensitivity Methods for Performance-Based Earthquake Engineering.* Terje Haukaas and Armen Der Kiureghian. April 2004.
- PEER 2003/13** *Effects of Connection Hysteretic Degradation on the Seismic Behavior of Steel Moment-Resisting Frames.* Janise E. Rodgers and Stephen A. Mahin. March 2004.
- PEER 2003/12** *Implementation Manual for the Seismic Protection of Laboratory Contents: Format and Case Studies.* William T. Holmes and Mary C. Comerio. October 2003.
- PEER 2003/11** *Fifth U.S.-Japan Workshop on Performance-Based Earthquake Engineering Methodology for Reinforced Concrete Building Structures.* February 2004.
- PEER 2003/10** *A Beam-Column Joint Model for Simulating the Earthquake Response of Reinforced Concrete Frames.* Laura N. Lowes, Nilanjan Mitra, and Arash Altoontash. February 2004.
- PEER 2003/09** *Sequencing Repairs after an Earthquake: An Economic Approach.* Marco Casari and Simon J. Wilkie. April 2004.
- PEER 2003/08** *A Technical Framework for Probability-Based Demand and Capacity Factor Design (DCFD) Seismic Formats.* Fatemeh Jalayer and C. Allin Cornell. November 2003.
- PEER 2003/07** *Uncertainty Specification and Propagation for Loss Estimation Using FOSM Methods.* Jack W. Baker and C. Allin Cornell. September 2003.
- PEER 2003/06** *Performance of Circular Reinforced Concrete Bridge Columns under Bidirectional Earthquake Loading.* Mahmoud M. Hachem, Stephen A. Mahin, and Jack P. Moehle. February 2003.
- PEER 2003/05** *Response Assessment for Building-Specific Loss Estimation.* Eduardo Miranda and Shahram Taghavi. September 2003.
- PEER 2003/04** *Experimental Assessment of Columns with Short Lap Splices Subjected to Cyclic Loads.* Murat Melek, John W. Wallace, and Joel Conte. April 2003.
- PEER 2003/03** *Probabilistic Response Assessment for Building-Specific Loss Estimation.* Eduardo Miranda and Hesameddin Aslani. September 2003.
- PEER 2003/02** *Software Framework for Collaborative Development of Nonlinear Dynamic Analysis Program.* Jun Peng and Kincho H. Law. September 2003.
- PEER 2003/01** *Shake Table Tests and Analytical Studies on the Gravity Load Collapse of Reinforced Concrete Frames.* Kenneth John Elwood and Jack P. Moehle. November 2003.
- PEER 2002/24** *Performance of Beam to Column Bridge Joints Subjected to a Large Velocity Pulse.* Natalie Gibson, André Filiatrault, and Scott A. Ashford. April 2002.
- PEER 2002/23** *Effects of Large Velocity Pulses on Reinforced Concrete Bridge Columns.* Greg L. Orozco and Scott A. Ashford. April 2002.
- PEER 2002/22** *Characterization of Large Velocity Pulses for Laboratory Testing.* Kenneth E. Cox and Scott A. Ashford. April 2002.
- PEER 2002/21** *Fourth U.S.-Japan Workshop on Performance-Based Earthquake Engineering Methodology for Reinforced Concrete Building Structures.* December 2002.
- PEER 2002/20** *Barriers to Adoption and Implementation of PBEE Innovations.* Peter J. May. August 2002.
- PEER 2002/19** *Economic-Engineered Integrated Models for Earthquakes: Socioeconomic Impacts.* Peter Gordon, James E. Moore II, and Harry W. Richardson. July 2002.
- PEER 2002/18** *Assessment of Reinforced Concrete Building Exterior Joints with Substandard Details.* Chris P. Pantelides, Jon Hansen, Justin Nadauld, and Lawrence D. Reaveley. May 2002.
- PEER 2002/17** *Structural Characterization and Seismic Response Analysis of a Highway Overcrossing Equipped with Elastomeric Bearings and Fluid Dampers: A Case Study.* Nicos Makris and Jian Zhang. November 2002.
- PEER 2002/16** *Estimation of Uncertainty in Geotechnical Properties for Performance-Based Earthquake Engineering.* Allen L. Jones, Steven L. Kramer, and Pedro Arduino. December 2002.
- PEER 2002/15** *Seismic Behavior of Bridge Columns Subjected to Various Loading Patterns.* Asadollah Esmaeily-Gh. and Yan Xiao. December 2002.

- PEER 2002/14** *Inelastic Seismic Response of Extended Pile Shaft Supported Bridge Structures.* T.C. Hutchinson, R.W. Boulanger, Y.H. Chai, and I.M. Idriss. December 2002.
- PEER 2002/13** *Probabilistic Models and Fragility Estimates for Bridge Components and Systems.* Paolo Gardoni, Armen Der Kiureghian, and Khalid M. Mosalam. June 2002.
- PEER 2002/12** *Effects of Fault Dip and Slip Rake on Near-Source Ground Motions: Why Chi-Chi Was a Relatively Mild M7.6 Earthquake.* Brad T. Aagaard, John F. Hall, and Thomas H. Heaton. December 2002.
- PEER 2002/11** *Analytical and Experimental Study of Fiber-Reinforced Strip Isolators.* James M. Kelly and Shakhzod M. Takhirov. September 2002.
- PEER 2002/10** *Centrifuge Modeling of Settlement and Lateral Spreading with Comparisons to Numerical Analyses.* Sivapalan Gajan and Bruce L. Kutter. January 2003.
- PEER 2002/09** *Documentation and Analysis of Field Case Histories of Seismic Compression during the 1994 Northridge, California, Earthquake.* Jonathan P. Stewart, Patrick M. Smith, Daniel H. Whang, and Jonathan D. Bray. October 2002.
- PEER 2002/08** *Component Testing, Stability Analysis and Characterization of Buckling-Restrained Unbonded Braces™.* Cameron Black, Nicos Makris, and Ian Aiken. September 2002.
- PEER 2002/07** *Seismic Performance of Pile-Wharf Connections.* Charles W. Roeder, Robert Graff, Jennifer Soderstrom, and Jun Han Yoo. December 2001.
- PEER 2002/06** *The Use of Benefit-Cost Analysis for Evaluation of Performance-Based Earthquake Engineering Decisions.* Richard O. Zerbe and Anthony Falit-Baiamonte. September 2001.
- PEER 2002/05** *Guidelines, Specifications, and Seismic Performance Characterization of Nonstructural Building Components and Equipment.* André Filiatrault, Constantin Christopoulos, and Christopher Stearns. September 2001.
- PEER 2002/04** *Consortium of Organizations for Strong-Motion Observation Systems and the Pacific Earthquake Engineering Research Center Lifelines Program: Invited Workshop on Archiving and Web Dissemination of Geotechnical Data, 4–5 October 2001.* September 2002.
- PEER 2002/03** *Investigation of Sensitivity of Building Loss Estimates to Major Uncertain Variables for the Van Nuys Testbed.* Keith A. Porter, James L. Beck, and Rustem V. Shaikhutdinov. August 2002.
- PEER 2002/02** *The Third U.S.-Japan Workshop on Performance-Based Earthquake Engineering Methodology for Reinforced Concrete Building Structures.* July 2002.
- PEER 2002/01** *Nonstructural Loss Estimation: The UC Berkeley Case Study.* Mary C. Comerio and John C. Stallmeyer. December 2001.
- PEER 2001/16** *Statistics of SDF-System Estimate of Roof Displacement for Pushover Analysis of Buildings.* Anil K. Chopra, Rakesh K. Goel, and Chatpan Chintanapakdee. December 2001.
- PEER 2001/15** *Damage to Bridges during the 2001 Nisqually Earthquake.* R. Tyler Ranf, Marc O. Eberhard, and Michael P. Berry. November 2001.
- PEER 2001/14** *Rocking Response of Equipment Anchored to a Base Foundation.* Nicos Makris and Cameron J. Black. September 2001.
- PEER 2001/13** *Modeling Soil Liquefaction Hazards for Performance-Based Earthquake Engineering.* Steven L. Kramer and Ahmed-W. Elgamal. February 2001.
- PEER 2001/12** *Development of Geotechnical Capabilities in OpenSees.* Boris Jeremić. September 2001.
- PEER 2001/11** *Analytical and Experimental Study of Fiber-Reinforced Elastomeric Isolators.* James M. Kelly and Shakhzod M. Takhirov. September 2001.
- PEER 2001/10** *Amplification Factors for Spectral Acceleration in Active Regions.* Jonathan P. Stewart, Andrew H. Liu, Yoojoong Choi, and Mehmet B. Baturay. December 2001.
- PEER 2001/09** *Ground Motion Evaluation Procedures for Performance-Based Design.* Jonathan P. Stewart, Shyh-Jeng Chiou, Jonathan D. Bray, Robert W. Graves, Paul G. Somerville, and Norman A. Abrahamson. September 2001.
- PEER 2001/08** *Experimental and Computational Evaluation of Reinforced Concrete Bridge Beam-Column Connections for Seismic Performance.* Clay J. Naito, Jack P. Moehle, and Khalid M. Mosalam. November 2001.
- PEER 2001/07** *The Rocking Spectrum and the Shortcomings of Design Guidelines.* Nicos Makris and Dimitrios Konstantinidis. August 2001.
- PEER 2001/06** *Development of an Electrical Substation Equipment Performance Database for Evaluation of Equipment Fragilities.* Thalia Agnanos. April 1999.

- PEER 2001/05** *Stiffness Analysis of Fiber-Reinforced Elastomeric Isolators.* Hsiang-Chuan Tsai and James M. Kelly. May 2001.
- PEER 2001/04** *Organizational and Societal Considerations for Performance-Based Earthquake Engineering.* Peter J. May. April 2001.
- PEER 2001/03** *A Modal Pushover Analysis Procedure to Estimate Seismic Demands for Buildings: Theory and Preliminary Evaluation.* Anil K. Chopra and Rakesh K. Goel. January 2001.
- PEER 2001/02** *Seismic Response Analysis of Highway Overcrossings Including Soil-Structure Interaction.* Jian Zhang and Nicos Makris. March 2001.
- PEER 2001/01** *Experimental Study of Large Seismic Steel Beam-to-Column Connections.* Egor P. Popov and Shakhzod M. Takhirov. November 2000.
- PEER 2000/10** *The Second U.S.-Japan Workshop on Performance-Based Earthquake Engineering Methodology for Reinforced Concrete Building Structures.* March 2000.
- PEER 2000/09** *Structural Engineering Reconnaissance of the August 17, 1999 Earthquake: Kocaeli (Izmit), Turkey.* Halil Sezen, Kenneth J. Elwood, Andrew S. Whittaker, Khalid Mosalam, John J. Wallace, and John F. Stanton. December 2000.
- PEER 2000/08** *Behavior of Reinforced Concrete Bridge Columns Having Varying Aspect Ratios and Varying Lengths of Confinement.* Anthony J. Calderone, Dawn E. Lehman, and Jack P. Moehle. January 2001.
- PEER 2000/07** *Cover-Plate and Flange-Plate Reinforced Steel Moment-Resisting Connections.* Taejin Kim, Andrew S. Whittaker, Amir S. Gilani, Vitelmo V. Bertero, and Shakhzod M. Takhirov. September 2000.
- PEER 2000/06** *Seismic Evaluation and Analysis of 230-kV Disconnect Switches.* Amir S. J. Gilani, Andrew S. Whittaker, Gregory L. Fenves, Chun-Hao Chen, Henry Ho, and Eric Fujisaki. July 2000.
- PEER 2000/05** *Performance-Based Evaluation of Exterior Reinforced Concrete Building Joints for Seismic Excitation.* Chandra Ciyde, Chris P. Pantelides, and Lawrence D. Reaveley. July 2000.
- PEER 2000/04** *An Evaluation of Seismic Energy Demand: An Attenuation Approach.* Chung-Che Chou and Chia-Ming Uang. July 1999.
- PEER 2000/03** *Framing Earthquake Retrofitting Decisions: The Case of Hillside Homes in Los Angeles.* Detlof von Winterfeldt, Nels Roselund, and Alicia Kitsuse. March 2000.
- PEER 2000/02** *U.S.-Japan Workshop on the Effects of Near-Field Earthquake Shaking.* Andrew Whittaker, ed. July 2000.
- PEER 2000/01** *Further Studies on Seismic Interaction in Interconnected Electrical Substation Equipment.* Armen Der Kiureghian, Kee-Jeung Hong, and Jerome L. Sackman. November 1999.
- PEER 1999/14** *Seismic Evaluation and Retrofit of 230-kV Porcelain Transformer Bushings.* Amir S. Gilani, Andrew S. Whittaker, Gregory L. Fenves, and Eric Fujisaki. December 1999.
- PEER 1999/13** *Building Vulnerability Studies: Modeling and Evaluation of Tilt-up and Steel Reinforced Concrete Buildings.* John W. Wallace, Jonathan P. Stewart, and Andrew S. Whittaker, editors. December 1999.
- PEER 1999/12** *Rehabilitation of Nonductile RC Frame Building Using Encasement Plates and Energy-Dissipating Devices.* Mehrdad Sasani, Vitelmo V. Bertero, James C. Anderson. December 1999.
- PEER 1999/11** *Performance Evaluation Database for Concrete Bridge Components and Systems under Simulated Seismic Loads.* Yael D. Hose and Frieder Seible. November 1999.
- PEER 1999/10** *U.S.-Japan Workshop on Performance-Based Earthquake Engineering Methodology for Reinforced Concrete Building Structures.* December 1999.
- PEER 1999/09** *Performance Improvement of Long Period Building Structures Subjected to Severe Pulse-Type Ground Motions.* James C. Anderson, Vitelmo V. Bertero, and Raul Bertero. October 1999.
- PEER 1999/08** *Envelopes for Seismic Response Vectors.* Charles Menun and Armen Der Kiureghian. July 1999.
- PEER 1999/07** *Documentation of Strengths and Weaknesses of Current Computer Analysis Methods for Seismic Performance of Reinforced Concrete Members.* William F. Cofer. November 1999.
- PEER 1999/06** *Rocking Response and Overturning of Anchored Equipment under Seismic Excitations.* Nicos Makris and Jian Zhang. November 1999.
- PEER 1999/05** *Seismic Evaluation of 550 kV Porcelain Transformer Bushings.* Amir S. Gilani, Andrew S. Whittaker, Gregory L. Fenves, and Eric Fujisaki. October 1999.
- PEER 1999/04** *Adoption and Enforcement of Earthquake Risk-Reduction Measures.* Peter J. May, Raymond J. Burby, T. Jens Feeley, and Robert Wood.

- PEER 1999/03** *Task 3 Characterization of Site Response General Site Categories.* Adrian Rodriguez-Marek, Jonathan D. Bray, and Norman Abrahamson. February 1999.
- PEER 1999/02** *Capacity-Demand-Diagram Methods for Estimating Seismic Deformation of Inelastic Structures: SDF Systems.* Anil K. Chopra and Rakesh Goel. April 1999.
- PEER 1999/01** *Interaction in Interconnected Electrical Substation Equipment Subjected to Earthquake Ground Motions.* Armen Der Kiureghian, Jerome L. Sackman, and Kee-Jeung Hong. February 1999.
- PEER 1998/08** *Behavior and Failure Analysis of a Multiple-Frame Highway Bridge in the 1994 Northridge Earthquake.* Gregory L. Fenves and Michael Ellery. December 1998.
- PEER 1998/07** *Empirical Evaluation of Inertial Soil-Structure Interaction Effects.* Jonathan P. Stewart, Raymond B. Seed, and Gregory L. Fenves. November 1998.
- PEER 1998/06** *Effect of Damping Mechanisms on the Response of Seismic Isolated Structures.* Nicos Makris and Shih-Po Chang. November 1998.
- PEER 1998/05** *Rocking Response and Overturning of Equipment under Horizontal Pulse-Type Motions.* Nicos Makris and Yiannis Roussos. October 1998.
- PEER 1998/04** *Pacific Earthquake Engineering Research Invitational Workshop Proceedings, May 14–15, 1998: Defining the Links between Planning, Policy Analysis, Economics and Earthquake Engineering.* Mary Comerio and Peter Gordon. September 1998.
- PEER 1998/03** *Repair/Upgrade Procedures for Welded Beam to Column Connections.* James C. Anderson and Xiaojing Duan. May 1998.
- PEER 1998/02** *Seismic Evaluation of 196 kV Porcelain Transformer Bushings.* Amir S. Gilani, Juan W. Chavez, Gregory L. Fenves, and Andrew S. Whittaker. May 1998.
- PEER 1998/01** *Seismic Performance of Well-Confined Concrete Bridge Columns.* Dawn E. Lehman and Jack P. Moehle. December 2000.

ONLINE REPORTS

The following PEER reports are available by Internet only at http://peer.berkeley.edu/publications/peer_reports.html

- PEER 2011/104** *Design and Instrumentation of the 2010 E-Defense Four-Story Reinforced Concrete and Post-Tensioned Concrete Buildings.* Takuya Nagae, Kenichi Tahara, Taizo Matsumori, Hitoshi Shiohara, Toshimi Kabeyasawa, Susumu Kono, Minehiro Nishiyama (Japanese Research Team) and John Wallace, Wassim Ghannoum, Jack Moehle, Richard Sause, Wesley Keller, Zeynep Tuna (U.S. Research Team). June 2011.
- PEER 2011/103** *In-Situ Monitoring of the Force Output of Fluid Dampers: Experimental Investigation.* Dimitrios Konstantinidis, James M. Kelly, and Nicos Makris. April 2011.
- PEER 2011/102** *Ground-motion prediction equations 1964 - 2010.* John Douglas. April 2011.
- PEER 2011/101** *Report of the Eighth Planning Meeting of NEES/E-Defense Collaborative Research on Earthquake Engineering.* Convened by the Hyogo Earthquake Engineering Research Center (NIED), NEES Consortium, Inc. February 2011.
- PEER 2010/111** *Modeling and Acceptance Criteria for Seismic Design and Analysis of Tall Buildings.* Task 7 Report for the Tall Buildings Initiative - Published jointly by the Applied Technology Council. October 2010.
- PEER 2010/110** *Seismic Performance Assessment and Probabilistic Repair Cost Analysis of Precast Concrete Cladding Systems for Multistory Buildings.* Jeffrey P. Hunt and Božidar Stojadinovic. November 2010.
- PEER 2010/109** *Report of the Seventh Joint Planning Meeting of NEES/E-Defense Collaboration on Earthquake Engineering. Held at the E-Defense, Miki, and Shin-Kobe, Japan, September 18–19, 2009.* August 2010.
- PEER 2010/108** *Probabilistic Tsunami Hazard in California.* Hong Kie Thio, Paul Somerville, and Jascha Polet, preparers. October 2010.
- PEER 2010/107** *Performance and Reliability of Exposed Column Base Plate Connections for Steel Moment-Resisting Frames.* Ady Aviram, Božidar Stojadinovic, and Armen Der Kiureghian. August 2010.
- PEER 2010/106** *Verification of Probabilistic Seismic Hazard Analysis Computer Programs.* Patricia Thomas, Ivan Wong, and Norman Abrahamson. May 2010.
- PEER 2010/105** *Structural Engineering Reconnaissance of the April 6, 2009, Abruzzo, Italy, Earthquake, and Lessons Learned.* M. Selim Günay and Khalid M. Mosalam. April 2010.
- PEER 2010/104** *Simulating the Inelastic Seismic Behavior of Steel Braced Frames, Including the Effects of Low-Cycle Fatigue.* Yuli Huang and Stephen A. Mahin. April 2010.
- PEER 2010/103** *Post-Earthquake Traffic Capacity of Modern Bridges in California.* Vesna Terzic and Božidar Stojadinović. March 2010.
- PEER 2010/102** *Analysis of Cumulative Absolute Velocity (CAV) and JMA Instrumental Seismic Intensity (I_{JMA}) Using the PEER-NGA Strong Motion Database.* Kenneth W. Campbell and Yousef Bozorgnia. February 2010.
- PEER 2010/101** *Rocking Response of Bridges on Shallow Foundations.* Jose A. Ugalde, Bruce L. Kutter, and Boris Jeremic. April 2010.
- PEER 2009/109** *Simulation and Performance-Based Earthquake Engineering Assessment of Self-Centering Post-Tensioned Concrete Bridge Systems.* Won K. Lee and Sarah L. Billington. December 2009.
- PEER 2009/108** *PEER Lifelines Geotechnical Virtual Data Center.* J. Carl Stepp, Daniel J. Ponti, Loren L. Turner, Jennifer N. Swift, Sean Devlin, Yang Zhu, Jean Benoit, and John Bobbitt. September 2009.
- PEER 2009/107** *Experimental and Computational Evaluation of Current and Innovative In-Span Hinge Details in Reinforced Concrete Box-Girder Bridges: Part 2: Post-Test Analysis and Design Recommendations.* Matias A. Hube and Khalid M. Mosalam. December 2009.
- PEER 2009/106** *Shear Strength Models of Exterior Beam-Column Joints without Transverse Reinforcement.* Sangjoon Park and Khalid M. Mosalam. November 2009.
- PEER 2009/105** *Reduced Uncertainty of Ground Motion Prediction Equations through Bayesian Variance Analysis.* Robb Eric S. Moss. November 2009.
- PEER 2009/104** *Advanced Implementation of Hybrid Simulation.* Andreas H. Schellenberg, Stephen A. Mahin, Gregory L. Fenves. November 2009.
- PEER 2009/103** *Performance Evaluation of Innovative Steel Braced Frames.* T. Y. Yang, Jack P. Moehle, and Božidar Stojadinovic. August 2009.

- PEER 2009/102** *Reinvestigation of Liquefaction and Nonliquefaction Case Histories from the 1976 Tangshan Earthquake.* Robb Eric Moss, Robert E. Kayen, Liyuan Tong, Songyu Liu, Guojun Cai, and Jiaer Wu. August 2009.
- PEER 2009/101** *Report of the First Joint Planning Meeting for the Second Phase of NEES/E-Defense Collaborative Research on Earthquake Engineering.* Stephen A. Mahin et al. July 2009.
- PEER 2008/104** *Experimental and Analytical Study of the Seismic Performance of Retaining Structures.* Linda Al Atik and Nicholas Sitar. January 2009.
- PEER 2008/103** *Experimental and Computational Evaluation of Current and Innovative In-Span Hinge Details in Reinforced Concrete Box-Girder Bridges. Part 1: Experimental Findings and Pre-Test Analysis.* Matias A. Hube and Khalid M. Mosalam. January 2009.
- PEER 2008/102** *Modeling of Unreinforced Masonry Infill Walls Considering In-Plane and Out-of-Plane Interaction.* Stephen Kadysiewski and Khalid M. Mosalam. January 2009.
- PEER 2008/101** *Seismic Performance Objectives for Tall Buildings.* William T. Holmes, Charles Kircher, William Petak, and Nabih Youssef. August 2008.
- PEER 2007/101** *Generalized Hybrid Simulation Framework for Structural Systems Subjected to Seismic Loading.* Tarek Elkhoraibi and Khalid M. Mosalam. July 2007.
- PEER 2007/100** *Seismic Evaluation of Reinforced Concrete Buildings Including Effects of Masonry Infill Walls.* Alidad Hashemi and Khalid M. Mosalam. July 2007.

The Pacific Earthquake Engineering Research Center (PEER) is a multi-institutional research and education center with headquarters at the University of California, Berkeley. Investigators from over 20 universities, several consulting companies, and researchers at various state and federal government agencies contribute to research programs focused on performance-based earthquake engineering.

These research programs aim to identify and reduce the risks from major earthquakes to life safety and to the economy by including research in a wide variety of disciplines including structural and geotechnical engineering, geology/seismology, lifelines, transportation, architecture, economics, risk management, and public policy.

PEER is supported by federal, state, local, and regional agencies, together with industry partners.



PEER reports can be ordered at http://peer.berkeley.edu/publications/peer_reports.html or by contacting

Pacific Earthquake Engineering Research Center
University of California, Berkeley
325 Davis Hall, mail code 1792
Berkeley, CA 94720-1792
Tel: 510-642-3437
Fax: 510-642-1655
Email: peer_editor@berkeley.edu

ISSN 1547-0587X